

Job Name:	
Tag#	



## Submittal Data Sheet

## FDXS09LVJU / RXS09LVJU

### 0.75-Ton Ducted Concealed Heat Pump System



Complete warranty details available from your local dealer or at [www.daikincomfort.com](http://www.daikincomfort.com). To receive the 12-Year Parts Limited Warranty, online registration must be completed within 60 days of installation. Online registration is not required in California or Quebec. *If product is installed in a commercial application, limited warranty period is 5 years.*

### Indoor Specifications

Airflow Rate (cfm)	Cooling		Heating	
	H	M	H	M
	L	SL	L	SL
	305	280	305	280
	260	235	260	235
Sound (dBA) H / M / L	35 / 33 / 31		35 / 33 / 31	
Dimensions (H x W x D) (in)	7-7/8 x 27-9/16 x 24-7/16			
Weight (Lbs)	47			

### Outdoor Specifications

Compressor	Hermetically Sealed Swing Type			
Refrigerant	R-410A			
Refrigerant Oil	PVE (FVC50K)			
Airflow Rate (cfm)	Cooling		Heating	
	H	M	H	M
	L	SL	L	SL
	1,102	989	992	840
Sound Power Level (dBA)	61 / 62			
Dimensions (H x W x D) (in)	21-5/8 x 30-1/8 x 11-1/4			
Weight (Lbs)	75			

### Efficiency

Cooling		Heating	
SEER	15.1	HSPF	10.3
EER	11.2	COP	3.45

### Performance

Cooling (Btu/hr)	
Rated (Min/Max)	8,500 (4,400 / 8,500)
Sensible @ AHRI	7,130
Moisture Removal gal/h	2.5
Standard Operating Range	50°F – 115°F
Extended Operating Range*	0°F – 115°F

Rated Cooling Conditions: Indoor: 80°F DB/67°F WB  
Outdoor: 95°F DB/75°F WB

\*With field settings and wind baffle

Heating (Btu/hr)	
1: @ 47° Rated (Min/Max )	10,000 (4,400 / 10,000)
2: @ 17° Rated	6,500
3: @ 5° Max	4,470
Operating Range	5°F – 65°F

1: Rated Heating Conditions: Indoor: 70°F DB/60°F WB  
Outdoor: 47°F DB/43°F WB  
2: Rated Heating Conditions: Indoor: 70°F DB/60°F WB  
Outdoor: 17°F DB/15°F WB  
3: Rated Heating Conditions: Indoor: 70°F DB/60°F WB  
Outdoor: 5°F DB/5°F WB

### Electrical

	208/60/1	230/60/1
System MCA	8	8
System MFA	15	15
Compressor RLA	4.1	3.7
Outdoor fan motor FLA	.22	.22
Outdoor fan motor W	23	23
Indoor fan motor FLA	.52	.52
Indoor fan motor W	62	62

MFA: Max. fuse amps MCA: Min. circuit amps (A) FLA: Full load amps (A)  
RLA: Rated load amps (A) W: Fan motor rated output (W)

### Piping

Liquid (in)	1/4
Gas (in)	3/8
Drain (in)	25/32
Max. Interunit Piping Length (ft)	65.6
Max. Interunit Height Difference (ft)	49.2
Chargeless (ft)	32.8
Additional Charge of Refrigerant (oz/ft)	.21

Daikin North America LLC 5151 San Felipe, Suite 500 Houston, TX 77056

(Daikin's products are subject to continuous improvements. Daikin reserves the right to modify product design, specifications and information in this data sheet without notice and without incurring any obligations)

# FDXS09LVJU Dimensional Data

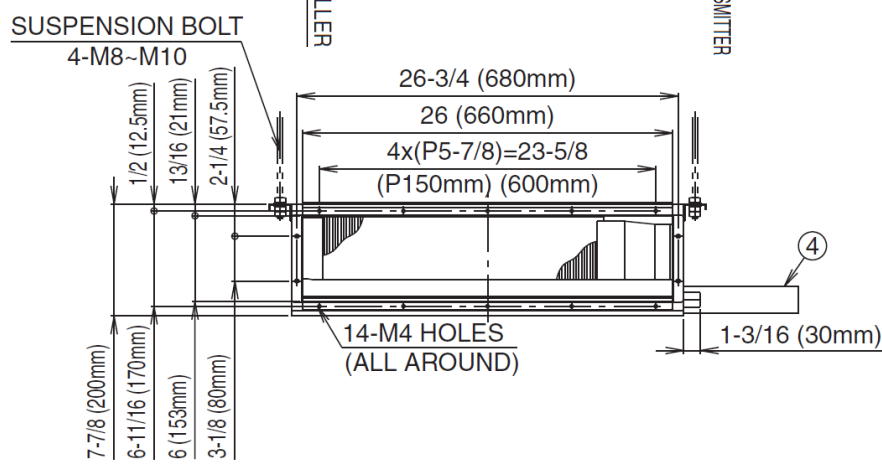
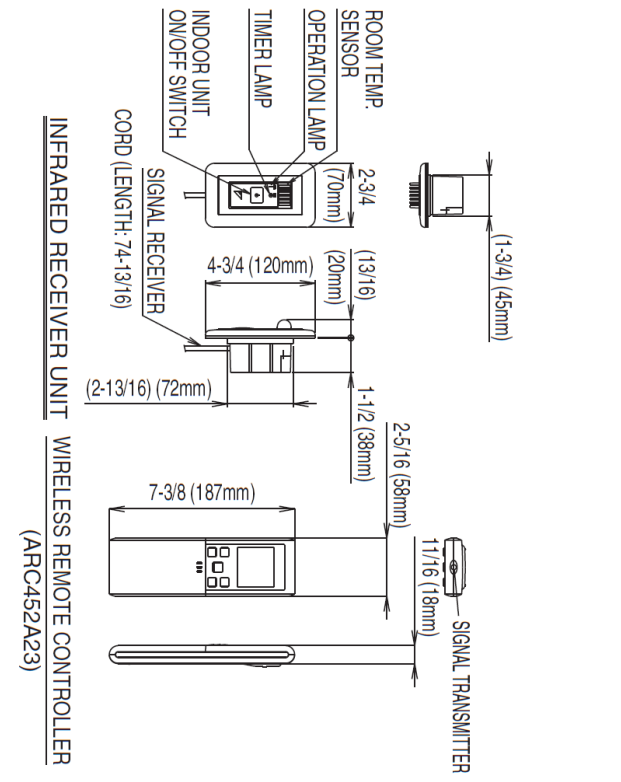
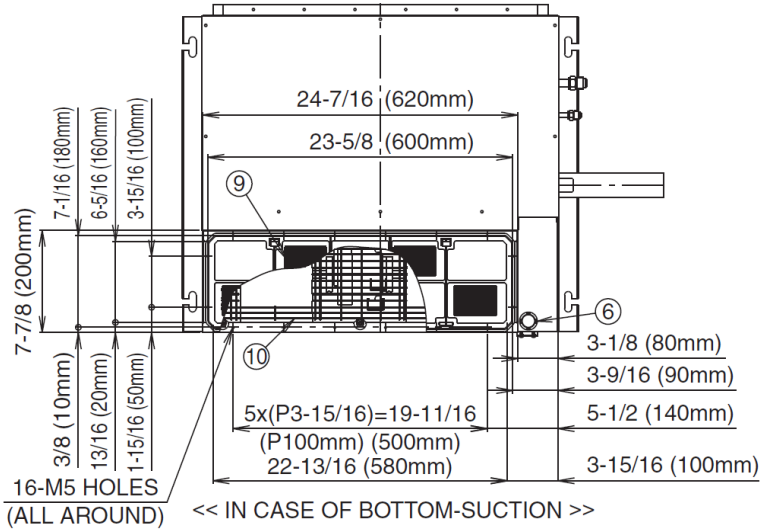
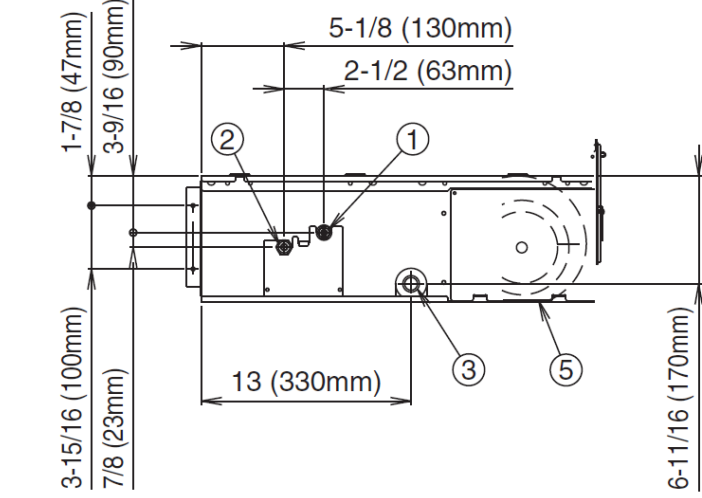
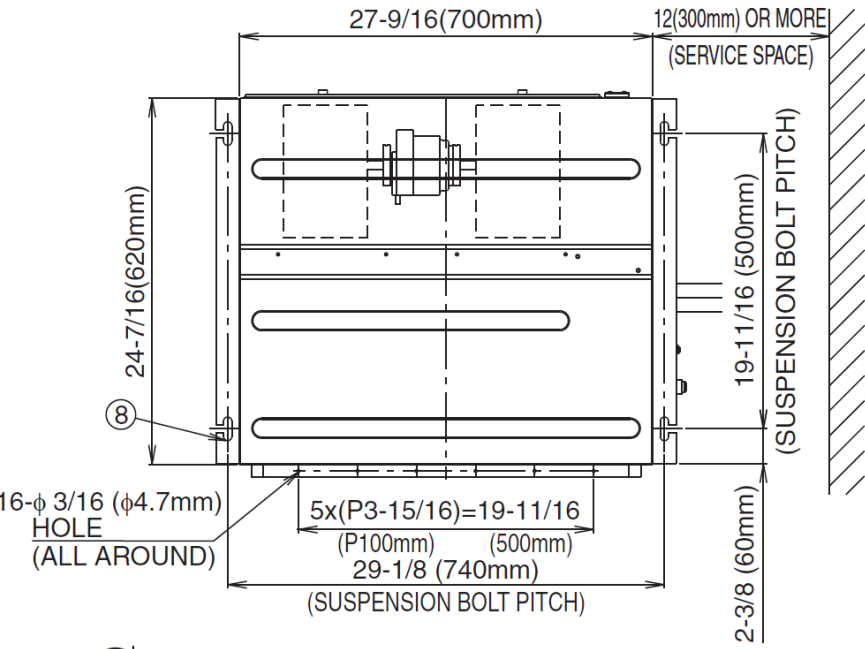

Daikin North America LLC 5151 San Felipe, Suite 500 Houston, TX 77056

(Daikin's products are subject to continuous improvements. Daikin reserves the right to modify product design, specifications and information in this data sheet without notice and without incurring any obligations)

# RXS09LVJU Dimensional Data

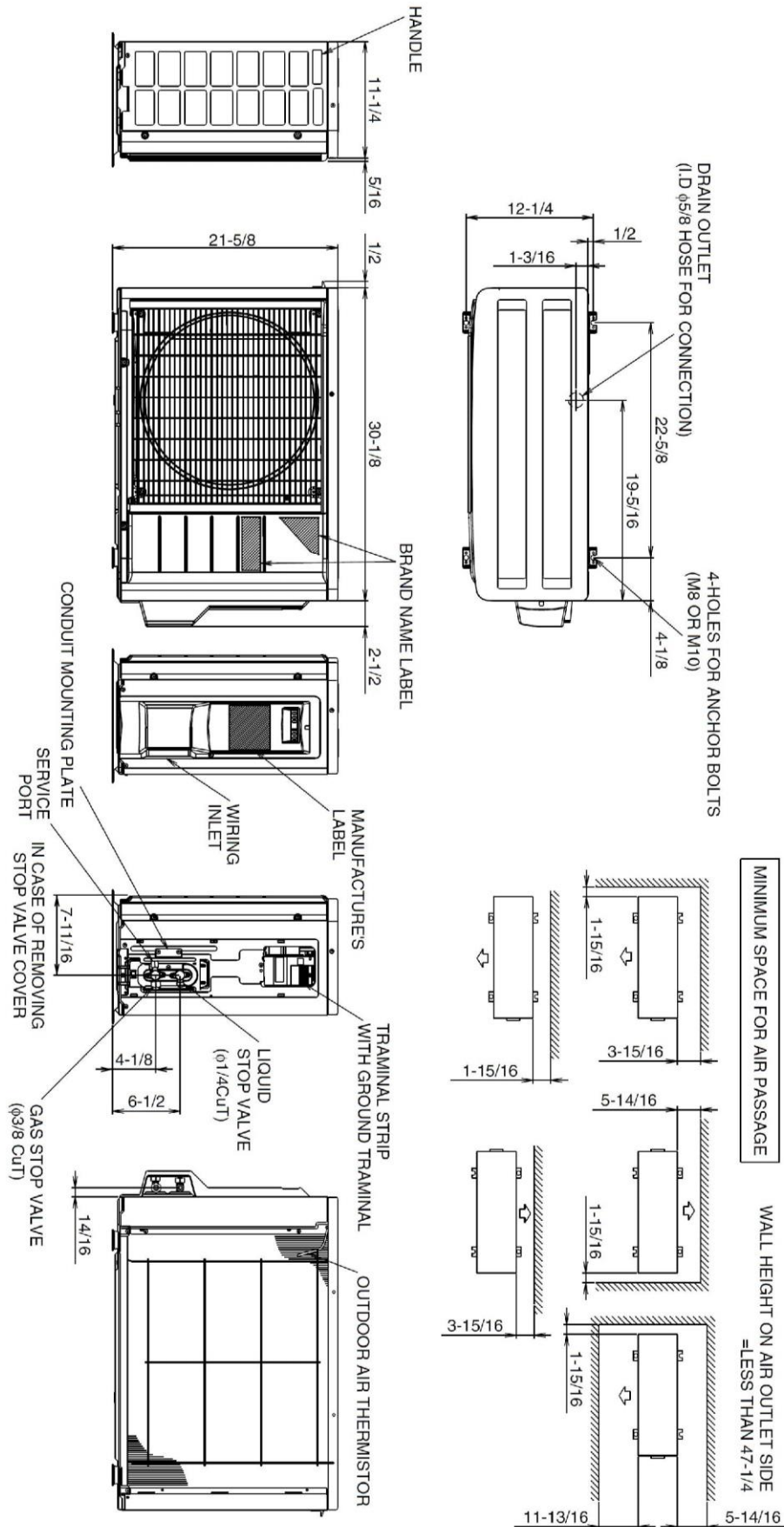

Daikin North America LLC 5151 San Felipe, Suite 500 Houston, TX 77056

(Daikin's products are subject to continuous improvements. Daikin reserves the right to modify product design, specifications and information in this data sheet without notice and without incurring any obligations)

Indoor Unit		
Included	Part Number	Description
	BRP072A43	Wireless Interface Adapter
	BRC944B2-A08	Wired Remote Controller
	BRCW901A08	Wired Remote Controller Cord - 3m
	DACA-BRCW901P10	Remote Controller Cable, Plenum Rated, 10 ft
	DACA-BRCW901P25	Remote Controller Cable, Plenum Rated, 25 ft
	DACA-ARCW901P10	IR Receiver Cable, Plenum Rated, 10ft
	DACA-ARCW901P25	IR Receiver Cable, Plenum Rated, 25ft
	DACA-TS1-1	Daikin ENVi Intelligent Thermostat Kit
	DACA-CP2-1	Maxi Orange Condensate Pump
	DACA-CP3-1	Mini Condensate Pump 5 gph
	KRP928BB2S	Interface Adaptor for DIII-NET

Outdoor Unit		
Included	Part Number	Description
	DACA-WB-3	Powder-Coated Wall-Mounted Bracket
	KEH041A41	Drain Pan Heater RXS09_12LV
	KEH041A42	Drain Pan Heater RXS15_18LV
	KKP937A4	Drain Plug for OD Unit
	KPW937C4	Low Ambient Wind Baffle / Air Adjustment Grille (09/12 MBH)