

THREE-PHASE PACKAGED AIR CONDITIONERS 15, 20, & 25 TONS

15 TONS COOLING CAPACITY: 180,000 BTU/H

20 TONS COOLING CAPACITY: 240,000 BTU/H

25 TONS COOLING CAPACITY: 290,000 BTU/H

■ Contents

Nomenclature.....	2
Product Specifications.....	3
Expanded Cooling Data	6
Airflow Data.....	12
Heating Kit Data	14
Dimensions	15
Roof Top Curb Installation	18
Wiring Diagrams	20
Accessories	26



■ Standard Features

- High-efficiency scroll compressor
- Copper tube / aluminum fin coils
- Aluminum micro-channel indoor coil on 25-ton units
- 25-ton models contain two outdoor fans
- High- and low-pressure switches
- High-capacity, steel-cased filter drier
- Heater kits with single-point entry
- Crankcase heaters
- 24-volt terminal strip
- Power block for field wiring
- Units meet the performance outlined in Table 6.8.1A of ASHRAE standard 90.1-2010
- AHRI Certified; ETL Listed

■ Cabinet Features

- Heavy-gauge, galvanized-steel cabinet with UV-resistant powder-paint finish
- Built-in filter rack with standard 2" filters (convertible to 4" filters)
- Full perimeter rail
- Sloped drain pan



* Complete warranty details available from your local dealer or at www.daikincomfort.com.

	D	C	C	180	060	3	B	*	*	*	A	*
	1	2	3	4,5,6	7,8,9	10	11	12	13	14	15	16
												Revision Levels
												Major & Minor
												Factory-Installed Options
Brand	D Daikin											X No Options
Configuration	C Standard Efficiency T High Efficiency											A Non-powered convenience outlet
Application	C Cooling G Gas Heat H Heat Pump											B Powered convenience outlet
Nominal Cooling Capacity	036 3 Tons 102 8½ Tons 300 25 Tons 048 4 Tons 120 10 Tons 060 5 Tons 150 12½ tons 072 6 Tons 180 15 Tons 090 7½ Tons 240 20 Tons											C Low-ambient kit
Nominal Heating Capacity												D Return air smoke detector
Gas/Electric	045 45,000 BTU/h XXX No Heat 090 90,000 BTU/h 010 10 kW 030 30 kW 115 115,000 BTU/h 015 15 kW 031 30 kW 140 140,000 BTU/h 016 15 kW 045 45 kW 210 210,000 BTU/h 018 18 kW 046 45 kW 350 350,000 BTU/h 020 20 kW 060 60 kW 400 400,000 BTU/h 025 25 kW											E Supply air smoke detector
A/C H/P Factory-Installed Electric Heat												F Non-powered convenience outlet; Low-ambient kit
See product specifications for heat size(s) available for each capacity.												G Non-powered convenience outlet; Return air smoke detector
Voltage	1 208-230/1/60 4 460/3/60 3 208-230/3/60 7 575/3/60											H Non-powered convenience outlet; Supply air smoke detector
Supply Fan/Drive Type/Motor	B Belt Drive (single speed) V Two-Speed Belt Drive D Direct Drive											J Non-powered convenience outlet; Return & Supply air smoke detectors
Factory-Installed Options	X No Options A Downflow Economizer H Disconnect Switch (non-fused) J Downflow Economizer; Disconnect Switch (non-fused)											K Non-powered convenience outlet; Low-ambient kit; Supply air smoke detector
Note: Not all options available for all products.												L Non-powered convenience outlet; Low-ambient kit
												M Powered convenience outlet; Low-ambient kit
												N Powered convenience outlet; Return air smoke detector
												O Powered convenience outlet; Return & Supply air smoke detectors
												P Powered convenience outlet; Supply air smoke detector
												Q Powered convenience outlet; Low-ambient kit; Return air smoke detector
												R Powered convenience outlet; Low-ambient kit; Supply air smoke detector
												T Powered convenience outlet; Low-ambient kit; Return & Supply air smoke detectors
												U Non-powered convenience outlet; Low-ambient kit; Return air smoke detector
												V Low-ambient kit; Return air smoke detector
												W Low-ambient kit; Supply air smoke detector
												Y Low-ambient kit; Return & Supply air smoke detectors
												Z Return & Supply air smoke detectors
												Factory-Installed Options
												X Standard Aluminized Heat Exchanger
												S Stainless-Steel Heat Exchanger

Factory-Installed Options

- Stainless-Steel Heat Exchanger (DCG/DTG units only): A tubular heat exchanger made of 409-type stainless steel is installed in the unit.
- Low-Ambient Kit: Allows for cooling operation at lower outdoor temperatures. On the 3- to 6-ton units, cooling operation is extended from 60°F ambient temperature to 35°F outside air temperature. On 7½ - 20 ton units, cooling operation is extended from 35°F ambient temperature to 0°F outside air temperature. For 25 ton units, cooling operation is extended from 24°F ambient temperature to 0°F outside air temperature.
- Economizers: Based on air conditions, can provide outside air to cool the space.
- Electric Heat Kits (DCC/DTC and DCH/DTH units only): Available in all voltage options.
- Non-powered Convenience Outlet: A 120V, 15A, GFCI outlet makes it easier for technicians to service the unit once an electrician runs power to the outlet.
- Powered Convenience Outlet: A 120V, 15A, GFCI outlet powered with a transformer built into the unit. When a factory-installed powered convenience outlet is installed in the equipment, the unit MCA (Min. Circuit Ampacity) will increase by 7.5A for 208/230V units, increase by 3.75A for 460V units, and by 3A for 575V units. The MOP (Max. Overcurrent Protection) device must be sized accordingly.
- Disconnect Switch (non-fused): A disconnect switch is installed in the unit and factory wiring will be complete from the switch to the unit. Please note that for air conditioning (DCC/DTC units) and heat pump models (DCH/DTH units), the appropriate electric heat kit must be ordered to be factory-installed along with the disconnect switch (non-fused) when it is ordered. Please note that for models with a powered convenience outlet option and a disconnect switch (non-fused) option, the power to the powered convenience outlet will be shut off when the disconnect switch (non-fused) is in the off position.
- Return Air and/or Supply Air Smoke Detectors: Return air and/or supply air smoke detectors are installed in the unit.
- Two-speed indoor fan blower models are available on 7½, 8½, 10, 12½, 15, 20, & 25-ton units. Section 6.4.3.10.b of ASHRAE Standard 90.1-2010 and Section 6.5.3.2.1.a of ASHRAE Standard 90.1-2013 require a minimum of two fan speeds. Section 140.4(m)1 of California Energy Commission Title 24 2013 contains a similar requirement.

	DCC180*** 3B***A*	DCC180*** 3V***A*	DCC180*** 4B***A*	DCC180*** 4V***A*	DCC180*** 7B***A*	DCC180*** 7V***A*
COOLING CAPACITY						
Total, BTU/h	180,000	180,000	180,000	180,000	180,000	180,000
Sensible BTU/h	134,600	134,600	134,600	134,600	134,600	134,600
EER / IEER	11 / 11.2	11 / 12.8	11 / 11.2	11 / 12.8	11 / 11.2	11 / 12.8
Decibels	88	88	88	88	88	88
ARI Reference #s	6572288	6502018	6572288	6502018	6572288	6502018
EVAPORATOR MOTOR / COIL						
Motor Type (Belt Drive)	Std Static	2-Speed Belt	Std Static	2-Speed Belt	Std Static	2-Speed Belt
Indoor Nominal CFM	6,000	6,000	6,000	6,000	6,000	6,000
Indoor Motor FLA (Cooling)	9.2	9.1	4.6	4.3	4.2	3.5
Horsepower - RPM (Speed: Full / Low)	3.0 - 1,725	3.0 - 1,760/1,165	3.0 - 1,725	3.0 - 1,760/1,165	3.0 - 1,725	3.0 - 1,760/1,165
Metering Device	TXV	TXV	TXV	TXV	TXV	TXV
Filter Size (#)	20 x 25 x 2 (6)	20 x 25 x 2 (6)	20 x 25 x 2 (6)	20 x 25 x 2 (6)	20 x 25 x 2 (6)	20 x 25 x 2 (6)
Drain Size (NPT)	1"	1"	1"	1"	1"	1"
R-410A Refrigerant Charge Cir #1	186.2	186.2	186.2	186.2	186.2	186.2
R-410A Refrigerant Charge Cir #2	170.8	170.8	170.8	170.8	170.8	170.8
Evaporator Coil Face Area (ft ²)	20	20	20	20	20	20
Rows Deep / Fins per Inch	4 / 16	4 / 16	4 / 16	4 / 16	4 / 16	4 / 16
BELT DRIVE EVAP FAN DATA						
# of Wheels (D x W)	2 (15" x 12")	2 (15" x 12")	2 (15" x 12")	2 (15" x 12")	2 (15" x 12")	2 (15" x 12")
Motor Sheave	1VM50 x 7/8"	1VP50 x 1 1/8"	1VM50 x 7/8"	1VP50 x 1 1/8"	1VM50 x 7/8"	1VP50 x 1 1/8"
Blower Sheave	BK100 x 1 3/16"	BK100 x 1 3/16"	BK100 x 1 3/16"	BK100 x 1 3/16"	BK100 x 1 3/16"	BK100 x 1 3/16"
Belt	BX45	BX44	BX45	BX44	BX45	BX44
CONDENSER FAN / COIL						
Quantity of Condenser Fan Motors	3	3	3	3	3	3
Horsepower - RPM	1/2 - 1,075	1/2 - 1,075	1/2 - 1,075	1/2 - 1,075	1/2 - 1,075	1/2 - 1,075
Fan Diameter / # Fan Blades	22 / 3	22 / 3	22 / 3	22 / 3	22 / 3	22 / 3
Outdoor Nominal CFM	9,000	9,000	9,000	9,000	9,000	9,000
Face Area (ft ²)	53.3	53.3	53.3	53.3	53.3	53.3
Rows Deep / Fins per Inch	2 / 27	2 / 27	2 / 27	2 / 27	2 / 27	2 / 27
COMPRESSOR						
Quantity / Type	2 / Scroll	2 / Scroll	2 / Scroll	2 / Scroll	2 / Scroll	2 / Scroll
Compressor RLA / LRA Circuit #1	25 / 164	25 / 164	12.2 / 100	12.2 / 100	9.0 / 78	9.0 / 78
Compressor RLA / LRA Circuit #2	25 / 164	25 / 164	12.2 / 100	12.2 / 100	9.0 / 78	9.0 / 78
ELECTRICAL DATA / STATIC						
Voltage / Phase (60 Hz)	208-230/3/60	208-230/3/60	460/3/60	460/3/60	575/3/60	575/3/60
Standard Max Static	1.2	1.2	1.2	1.2	1.2	1.2
Outdoor Fan FLA / LRA	2.0/4.4	2.0/4.4	.9/2.2	.9/2.2	0.9 / 2.2	0.9 / 2.2
Total Unit Amps	65.2	65.1	31.7	31.4	24.9	24.2
Min. Circuit Ampacity ¹	72	71	35	35	27	27
Max. Overcurrent Protection (amps) ²	90	90	45	45	35	35
Entrance Power Supply	2 1/2"	2 1/2"	2 1/2"	2 1/2"	2 1/2"	2 1/2"
Entrance Control Voltage	7/8"	7/8"	7/8"	7/8"	7/8"	7/8"
OPERATING WEIGHT (LBS)	1965	1965	1965	1965	1965	1965
SHIP WEIGHT (LBS)	2080	2080	2080	2080	2080	2080

¹ Wire size should be determined in accordance with National Electrical Codes. Extensive wire runs will require larger wire sizes.

² May use fuses or HACR-type circuit breakers of the same size as noted.

Note: Always check the S&R plate for electrical data on the unit being installed.

	DCC240 ***3B***A*	DCC240 ***3V***A*	DCC240 ***4B***A*	DCC240 ***4V***A*	DCC240 ***7B***A*	DCC240 ***7V***A*
COOLING CAPACITY						
Total, BTU/h	240,000	240,000	240,000	240,000	240,000	240,000
Sensible BTU/h	181,000	181,000	181,000	181,000	181,000	181,000
EER / IEER	10.0 / 10.1	10.0 / 11.5	10.0 / 10.1	10.0 / 11.5	10.0 / 10.1	10.0 / 11.5
Decibels	88	88	88	88	88	88
ARI Reference #s	6502023	6502020	6502023	6502020	6502023	6502020
EVAPORATOR MOTOR / COIL						
Motor Type (Belt Drive)	Std Static	2-Speed Belt	Std Static	2-Speed Belt	Std Static	2-Speed Belt
Indoor Nominal CFM	7,000	7,000	7,000	7,000	7,000	7,000
Indoor Motor FLA (Cooling)	12.7	14	6.4	6.6	5.1	5.2
Horsepower - RPM (Speed: Full / Low)	5.0 - 1,725	5.0 - 1,775/1,185	5.0 - 1,725	5.0 - 1,775/1,185	5.0 - 1,725	5.0 - 1,775/1,185
Metering Device	TXV	TXV	TXV	TXV	TXV	TXV
Filter Size (#)	20 x 25 x 2 (6)	20 x 25 x 2 (6)	20 x 25 x 2 (6)	20 x 25 x 2 (6)	20 x 25 x 2 (6)	20 x 25 x 2 (6)
Drain Size (NPT)	1"	1"	1"	1"	1"	1"
R-410A Refrigerant Charge Cir #s 1 & 2	200 ozs.	200 ozs.	200 ozs.	200 ozs.	200 ozs.	200 ozs.
Face Area (ft ²)	20	20	20	20	20	20
Rows Deep / Fins per Inch	4 / 16	4 / 16	4 / 16	4 / 16	4 / 16	4 / 16
BELT DRIVE EVAP FAN DATA						
# of Wheels (D x W)	2 (15" x 15")	2 (15" x 15")	2 (15" x 15")	2 (15" x 15")	2 (15" x 15")	2 (15" x 15")
Motor Sheave	1VP60 x 1½"	1VP60 x 1¾"	1VP60 x 1½"	1VP60 x 1¾"	1VP60 x 1½"	1VP60 x 1¾"
Blower Sheave	BK100 x 17/16"	BK100 x 17/16"	BK100 x 17/16"	BK100 x 17/16"	BK100 x 17/16"	BK100 x 17/16"
Belt	BX46	BX45	BX46	BX45	BX46	BX45
CONDENSER FAN / COIL						
Quantity of Condenser Fan Motors	3	3	3	3	3	3
Horsepower - RPM	½ - 1,075	½ - 1,075	½ - 1,075	½ - 1,075	½ - 1,075	½ - 1,075
Fan Diameter / # Fan Blades	22 / 3	22 / 3	22 / 3	22 / 3	22 / 3	22 / 3
Outdoor Nominal CFM	9,000	9,000	9,000	9,000	9,000	9,000
Face Area (ft ²)	53.3	53.3	53.3	53.3	53.3	53.3
Rows Deep / Fins per Inch	2 / 27	2 / 27	2 / 27	2 / 27	2 / 27	2 / 27
COMPRESSOR						
Quantity / Type	2 / Scroll	2 / Scroll	2 / Scroll	2 / Scroll	2 / Scroll	2 / Scroll
Compressor RLA / LRA CIR. #1	33.3 / 239	33.3 / 239	17.9 / 125	17.9 / 125	12.8 / 80	12.8 / 80
Compressor RLA / LRA CIR. #2	33.3 / 239	33.3 / 239	17.9 / 125	17.9 / 125	12.8 / 80	12.8 / 80
ELECTRICAL DATA / STATIC						
Voltage / Phase (60 Hz)	208-230/ 3	208-230/ 3	460/ 3	460/ 3	575/ 3	575/ 3
Outdoor Fan FLA / LRA	2.0/4.4	2.0/4.4	.9/2.2	.9/2.2	0.9 / 2.2	0.9 / 2.2
Total Unit Amps	85.3	86.6	44.9	45.1	33.4	33.5
Min. Circuit Ampacity ¹	94	95	49	50	37	37
Max. Overcurrent Protection (amps) ²	125	125	60	60	45	45
Entrance Power Supply	2½"	2½"	2½"	2½"	2½"	2½"
Entrance Control Voltage	⅞"	⅞"	⅞"	⅞"	⅞"	⅞"
OPERATING WEIGHT (LBS)						
	2085	2085	2085	2085	2085	2085
SHIP WEIGHT (LBS)						
	2202	2202	2202	2202	2202	2202

¹ Wire size should be determined in accordance with National Electrical Codes. Extensive wire runs will require larger wire sizes.

² May use fuses or HACR-type circuit breakers of the same size as noted.

Note: Always check the S&R plate for electrical data on the unit being installed.

	DCC300 ***3B***A*	DCC300 ***3V***A*	DCC300 ***4B***A*	DCC300 ***4V***A*	DCC300 ***7B***A*	DCC300 ***7V***A*
COOLING CAPACITY						
Total, BTU/h	290,000	290,000	290,000	290,000	290,000	290,000
Sensible BTU/h	196,000	196,000	196,000	196,000	196,000	196,000
EER / IEER	10.2 / 11.2	10.2 / 11.8	10.2 / 11.2	10.2 / 11.8	10.2 / 11.2	10.2 / 11.8
Decibels	92	92	92	92	92	92
AHRI Reference #s	8199469	8582013	8199469	8582013	8199469	8582013
EVAPORATOR MOTOR / COIL						
Motor Type (Belt Drive)	Std Static	Std Static	Std Static	Std Static	Std Static	Std Static
Indoor Nominal CFM	8,200	8,200	8,200	8,200	8,200	8,200
Indoor Motor FLA (Cooling)	20.4	21.0	9.41	10.1	7.5	8.2
Horsepower - RPM (Speed: Full / Low)	7.5 - 1745	7.5 - 1770/1175	7.5 - 1745	7.5 - 1770/1175	7.5 - 1745	7.5 - 1770/1175
Metering Device	TXV	TXV	TXV	TXV	TXV	TXV
Filter Size (#)	20 x 20 x 2 (8)	20 x 20 x 2 (8)	20 x 20 x 2 (8)	20 x 20 x 2 (8)	20 x 20 x 2 (8)	20 x 20 x 2 (8)
Drain Size (NPT)	1"	1"	1"	1"	1"	1"
R-410A Refrigerant Charge Cir #s 1 & 2	215 & 198 ozs.	215 & 198 ozs.	215 & 198 ozs.	215 & 198 ozs.	215 & 198 ozs.	215 & 198 ozs.
Face Area (ft ²)	17.2	17.2	17.2	17.2	17.2	17.2
Rows Deep / Fins per Inch	2 / 15	2 / 15	2 / 15	2 / 15	2 / 15	2 / 15
BELT DRIVE EVAP FAN DATA						
# of Wheels (D x W)	2 (15" x 15")	2 (15" x 15")	2 (15" x 15")	2 (15" x 15")	2 (15" x 15")	2 (15" x 15")
Motor Sheave	1VP60 x 1 $\frac{3}{8}$ "	1VP60 x 1 $\frac{3}{8}$ "	1VP60 x 1 $\frac{3}{8}$ "	1VP60 x 1 $\frac{3}{8}$ "	1VP60 x 1 $\frac{3}{8}$ "	1VP60 x 1 $\frac{3}{8}$ "
Blower Sheave	BK110 x 1 $\frac{7}{16}$ "	BK110 x 1 $\frac{7}{16}$ "	BK110 x 1 $\frac{7}{16}$ "	BK110 x 1 $\frac{7}{16}$ "	BK110 x 1 $\frac{7}{16}$ "	BK110 x 1 $\frac{7}{16}$ "
Belt	BX46	BX46	BX46	BX46	BX46	BX46
CONDENSER FAN / COIL						
Quantity of Condenser Fan Motors	2	2	2	2	2	2
Horsepower - RPM	1 - 1145	1 - 1145	1 - 1145	1 - 1145	1 - 1145	1 - 1145
Fan Diameter / # Fan Blades	30 / 2	30 / 2	30 / 2	30 / 2	30 / 2	30 / 2
Outdoor Nominal CFM	15,000	15,000	15,000	15,000	15,000	15,000
Face Area (ft ²)	53.3	53.3	53.3	53.3	53.3	53.3
Rows Deep / Fins per Inch	2 / 27	2 / 27	2 / 27	2 / 27	2 / 27	2 / 27
COMPRESSOR						
Quantity / Type	2 / Scroll	2 / Scroll	2 / Scroll	2 / Scroll	2 / Scroll	2 / Scroll
Compressor RLA / LRA CIR. #1	48.1 / 245	48.1 / 245	18.6 / 125	18.6 / 125	14.7 / 100	14.7 / 100
Compressor RLA / LRA CIR. #2	48.1 / 245	48.1 / 245	18.6 / 125	18.6 / 125	14.7 / 100	14.7 / 100
ELECTRICAL DATA						
Voltage / Phase (60 Hz)	208-230/ 3	208-230/ 3	460/ 3	460/ 3	575/ 3	575/ 3
Outdoor Fan FLA / LRA	4.5/ 24.1	4.5/24.1	2.1/ 12.2	2.1/12.2	1.6/ 6.5	1.6/6.5
Total Unit Amps	125.6	126.2	50.8	51.5	40.1	40.8
Min. Circuit Ampacity ¹	137.6	138.2	55.4	56.1	43.9	44.6
Max. Overcurrent Protection (amps) ²	175	175	70	70	50	50
Entrance Power Supply	2 $\frac{1}{8}$ "	2 $\frac{1}{8}$ "	2 $\frac{1}{8}$ "	2 $\frac{1}{8}$ "	2 $\frac{1}{8}$ "	2 $\frac{1}{8}$ "
Entrance Control Voltage	$\frac{7}{8}$ "	$\frac{7}{8}$ "	$\frac{7}{8}$ "	$\frac{7}{8}$ "	$\frac{7}{8}$ "	$\frac{7}{8}$ "
OPERATING WEIGHT (LBS)	2109	2119	2109	2119	2109	2119
SHIP WEIGHT (LBS)	2377	2387	2377	2387	2377	2387

¹ Wire size should be determined in accordance with National Electrical Codes. Extensive wire runs will require larger wire sizes.

² May use fuses or HACR-type circuit breakers of the same size as noted.

Note: Always check the S&R plate for electrical data on the unit being installed.

IDB		OUTDOOR AMBIENT TEMPERATURE																																			
		65						75						85						95						105						115					
		AIRFLOW				ENTERING INDOOR WET BULB TEMPERATURE				ENTERING INDOOR WET BULB TEMPERATURE				ENTERING INDOOR WET BULB TEMPERATURE				ENTERING INDOOR WET BULB TEMPERATURE				ENTERING INDOOR WET BULB TEMPERATURE				ENTERING INDOOR WET BULB TEMPERATURE				ENTERING INDOOR WET BULB TEMPERATURE							
59	63	67	71	59	63	67	71	59	63	67	71	59	63	67	71	59	63	67	71	59	63	67	71	59	63	67	71	59	63	67	71						
70	MBh	176.4	182.8	200.3	-	172.3	178.6	195.6	-	168.2	174.3	191.0	-	164.1	170.1	186.3	-	155.9	161.6	177.0	-	144.4	149.7	164.0	-	144.4	149.7	164.0	-	144.4	149.7	164.0	-				
	S/T	0.75	0.63	0.43	-	0.78	0.65	0.45	-	0.80	0.67	0.46	-	0.82	0.69	0.48	-	0.86	0.71	0.49	-	0.86	0.72	0.50	-	0.86	0.72	0.50	-	0.86	0.72	0.50	-				
	ΔT	18	16	12	-	18	16	12	-	18	16	12	-	18	16	12	-	18	16	12	-	17	15	11	-	17	15	11	-	17	15	11	-				
	HI PR	236	253	268	-	264	284	300	-	301	323	342	-	342	368	389	-	385	414	438	-	425	458	484	-	425	458	484	-	425	458	484	-				
	LO PR	103	110	120	-	109	116	127	-	114	121	132	-	119	127	139	-	125	133	145	-	129	138	150	-	129	138	150	-	129	138	150	-				
75	MBh	171.2	177.5	194.5	-	167.3	173.4	189.9	-	163.3	169.2	185.4	-	159.3	165.1	180.9	-	151.3	156.9	171.9	-	140.2	145.3	159.2	-	140.2	145.3	159.2	-	140.2	145.3	159.2	-				
	S/T	0.72	0.60	0.41	-	0.74	0.62	0.43	-	0.76	0.64	0.44	-	0.79	0.66	0.45	-	0.82	0.68	0.47	-	0.82	0.69	0.48	-	0.82	0.69	0.48	-	0.82	0.69	0.48	-				
	ΔT	19	16	12	-	19	16	13	-	19	16	13	-	19	17	13	-	19	16	12	-	18	15	12	-	18	15	12	-	18	15	12	-				
	HI PR	233	251	265	-	262	282	297	-	298	320	338	-	339	365	385	-	381	410	433	-	421	453	479	-	421	453	479	-	421	453	479	-				
	LO PR	102	109	119	-	108	115	126	-	112	120	131	-	118	126	137	-	124	132	144	-	128	136	149	-	128	136	149	-	128	136	149	-				
80	MBh	158.1	163.8	179.5	-	154.4	160.0	175.3	-	150.7	156.2	171.1	-	147.0	152.4	167.0	-	139.7	144.8	158.6	-	129.4	134.1	146.9	-	129.4	134.1	146.9	-	129.4	134.1	146.9	-				
	S/T	0.69	0.58	0.40	-	0.72	0.60	0.41	-	0.73	0.61	0.42	-	0.76	0.63	0.44	-	0.79	0.66	0.46	-	0.79	0.66	0.46	-	0.79	0.66	0.46	-	0.79	0.66	0.46	-				
	ΔT	21	18	14	-	21	18	14	-	21	18	14	-	21	18	14	-	21	18	14	-	20	17	13	-	20	17	13	-	20	17	13	-				
	HI PR	226	243	257	-	254	273	288	-	289	311	328	-	329	354	374	-	370	398	420	-	409	440	464	-	409	440	464	-	409	440	464	-				
	LO PR	99	106	115	-	105	112	122	-	109	116	127	-	115	122	133	-	120	128	139	-	124	132	144	-	124	132	144	-	124	132	144	-				
85	MBh	179.4	184.7	199.9	214.5	175.2	180.4	195.3	209.6	171.0	176.1	190.6	204.6	166.9	171.8	186.0	199.6	158.5	163.2	176.7	189.6	146.8	151.2	163.6	175.6	146.8	151.2	163.6	175.6								
	S/T	0.85	0.76	0.58	0.37	0.89	0.79	0.60	0.39	0.91	0.81	0.61	0.40	0.94	0.84	0.63	0.41	0.97	0.87	0.66	0.42	0.98	0.88	0.66	0.43	0.98	0.88	0.66	0.43								
	ΔT	21	19	16	11	21	19	16	11	21	19	16	11	21	20	16	11	21	19	16	11	20	18	15	10	20	18	15	10								
	HI PR	238	256	270	282	267	287	303	316	304	327	345	360	346	372	393	410	389	419	442	461	430	463	488	509	430	463	488	509								
	LO PR	104	111	121	129	110	117	128	137	115	122	133	142	121	128	140	149	126	134	147	156	131	139	152	162	131	139	152	162								
90	MBh	174.2	179.3	194.1	208.3	170.1	175.1	189.6	203.5	166.1	171.0	185.1	198.6	162.0	166.8	180.5	193.8	153.9	158.5	171.5	184.1	142.6	146.8	158.9	170.5	142.6	146.8	158.9	170.5								
	S/T	0.81	0.73	0.55	0.35	0.84	0.76	0.57	0.37	0.87	0.77	0.59	0.38	0.89	0.80	0.60	0.39	0.93	0.83	0.63	0.40	0.94	0.84	0.63	0.41	0.94	0.84	0.63	0.41								
	ΔT	22	20	16	11	22	20	17	11	22	20	17	11	22	20	17	12	22	20	16	11	20	19	15	11	20	19	15	11								
	HI PR	236	253	268	279	264	284	300	313	301	323	342	356	342	368	389	406	385	415	438	457	426	458	484	504	426	458	484	504								
	LO PR	103	110	120	128	109	116	127	135	114	121	132	141	119	127	139	148	125	133	145	155	129	138	150	160	129	138	150	160								
95	MBh	160.7	165.5	179.1	192.3	157.0	161.6	175.0	187.8	153.3	157.8	170.8	183.3	149.5	154.0	166.6	178.8	142.0	146.3	158.3	169.9	131.6	135.5	146.6	157.4	131.6	135.5	146.6	157.4								
	S/T	0.79	0.70	0.53	0.34	0.81	0.73	0.55	0.35	0.83	0.75	0.56	0.36	0.86	0.77	0.58	0.38	0.89	0.80	0.61	0.39	0.90	0.81	0.61	0.39	0.90	0.81	0.61	0.39								
	ΔT	24	22	18	13	24	23	18	13	25	23	18	13	25	23	19	13	24	22	18	13	23	21	17	12	23	21	17	12								
	HI PR	228	246	260	271	256	276	291	304	292	314	331	346	332	357	377	394	374	402	425	443	413	444	469	489	413	444	469	489								
	LO PR	100	107	117	124	106	113	123	131	110	117	128	136	116	123	134	143	121	129	141	150	125	133	146	155	125	133	146	155								

IDB: Entering Indoor Dry Bulb Temperature

Shaded area reflects ACCA (TVA) conditions

High and low pressures are measured at the liquid and suction access fittings.

IDB		OUTDOOR AMBIENT TEMPERATURE																																			
		65						75						85						95						105						115					
		AIRFLOW				ENTERING INDOOR WET BULB TEMPERATURE				ENTERING INDOOR WET BULB TEMPERATURE				ENTERING INDOOR WET BULB TEMPERATURE				ENTERING INDOOR WET BULB TEMPERATURE				ENTERING INDOOR WET BULB TEMPERATURE				ENTERING INDOOR WET BULB TEMPERATURE				ENTERING INDOOR WET BULB TEMPERATURE							
59	63	67	71	59	63	67	71	59	63	67	71	59	63	67	71	59	63	67	71	59	63	67	71	59	63	67	71	59	63	67	71						
80	6750	MBh	182.6	186.5	199.3	213.1	178.3	182.2	194.7	208.1	174.1	177.9	190.0	203.1	169.8	173.5	185.4	198.2	161.3	164.9	176.1	188.3	149.4	152.7	163.2	174.4	149.4	152.7	163.2	174.4							
		S/T	0.94	0.88	0.71	0.53	0.97	0.91	0.74	0.55	1.00	0.93	0.76	0.57	1.00	0.96	0.78	0.59	1.00	1.00	0.81	0.61	1.00	1.00	0.82	0.61	1.00	1.00	0.82	0.61							
		ΔT	23	22	19	16	24	23	20	16	24	23	20	16	23	23	20	16	22	22	20	16	20	21	18	15	20	21	18	15							
		HI PR	240	259	273	285	270	290	306	320	307	330	349	363	349	376	397	414	393	423	447	466	434	467	493	515	434	467	493	515							
		LO PR	106	112	123	131	112	119	130	138	116	123	135	143	122	130	141	151	128	136	148	158	132	140	153	163	132	140	153	163							
80	6000	MBh	177.2	180.1	193.5	206.9	173.1	176.9	189.0	202.0	169.0	172.7	184.5	197.2	164.9	168.5	180.0	192.4	156.6	160.1	171.0	182.8	145.1	148.3	158.4	169.3	145.1	148.3	158.4	169.3							
		S/T	0.89	0.84	0.68	0.51	0.93	0.87	0.71	0.53	0.95	0.89	0.72	0.54	0.98	0.92	0.75	0.56	1.00	0.95	0.78	0.58	1.00	0.96	0.78	0.59	1.00	0.96	0.78	0.59							
		ΔT	24	23	20	16	25	24	20	16	25	24	20	16	25	24	21	16	24	23	20	16	22	22	19	15	22	22	19	15							
		HI PR	238	256	270	282	267	287	303	316	304	327	345	360	346	372	393	410	389	419	442	461	430	463	488	510	430	463	488	510							
		LO PR	105	111	121	129	110	117	128	137	115	122	133	142	121	128	140	149	126	134	147	156	131	139	152	162	131	139	152	162							
80	4800	MBh	163.6	167.2	178.6	190.9	159.8	163.3	174.4	186.5	156.0	159.4	170.3	182.0	152.2	155.5	166.1	177.6	144.6	147.7	157.8	168.7	133.9	136.8	146.2	156.3	133.9	136.8	146.2	156.3							
		S/T	0.86	0.81	0.66	0.49	0.89	0.84	0.68	0.51	0.92	0.86	0.70	0.52	0.94	0.89	0.72	0.54	0.98	0.92	0.75	0.56	0.99	0.93	0.75	0.56	0.99	0.93	0.75	0.56							
		ΔT	27	26	22	18	27	26	23	18	27	26	23	18	28	26	23	18	27	26	23	18	25	24	21	17	25	24	21	17							
		HI PR	231	248	262	274	259	279	294	307	295	317	335	349	335	361	381	398	377	406	429	447	417	449	474	494	417	449	474	494							
		LO PR	101	108	118	125	107	114	124	132	111	118	129	138	117	124	136	145	123	130	142	152	127	135	147	157	127	135	147	157							
85	6750	MBh	185.8	189.3	198.3	211.6	180.4	184.9	193.7	206.6	177.1	180.5	189.1	201.7	172.8	176.1	184.5	196.8	164.2	167.3	175.2	187.0	152.1	155.0	162.3	173.2	152.1	155.0	162.3	173.2							
		S/T	0.98	0.95	0.86	0.69	1.00	0.98	0.89	0.72	1.00	1.00	0.91	0.74	1.00	1.00	0.94	0.76	1.00	1.00	0.97	0.79	1.00	1.00	0.98	0.80	1.00	1.00	0.98	0.80							
		ΔT	25	24	23	20	25	25	23	20	24	25	23	20	24	24	24	20	22	23	23	20	21	21	22	19	21	21	22	19							
		HI PR	243	261	276	288	272	293	309	323	310	333	352	367	353	380	401	418	397	427	451	470	439	472	498	520	439	472	498	520							
		LO PR	107	113	124	132	113	120	131	139	117	125	136	145	123	131	143	152	129	137	150	159	133	142	155	165	133	142	155	165							
85	6000	MBh	180.3	183.8	192.5	205.4	176.1	179.6	188.1	200.6	172.0	175.3	183.6	195.8	167.8	171.0	179.1	191.1	159.4	162.5	170.1	180.5	147.6	150.5	157.6	168.1	147.6	150.5	157.6	168.1							
		S/T	0.94	0.90	0.82	0.66	0.97	0.94	0.85	0.69	1.00	0.96	0.87	0.70	1.00	0.99	0.89	0.73	1.00	1.00	0.93	0.75	1.00	1.00	0.94	0.76	1.00	1.00	0.94	0.76							
		ΔT	26	25	24	21	26	26	24	21	26	26	24	21	26	26	25	21	24	25	24	21	23	23	23	20	23	23	23	20							
		HI PR	240	259	273	285	270	290	306	320	307	330	349	363	349	376	397	414	393	423	447	466	434	467	493	515	434	467	493	515							
		LO PR	106	112	123	131	112	119	130	138	116	123	135	143	122	130	141	151	128	136	148	158	132	140	153	163	132	140	153	163							
85	4800	MBh	166.5	169.7	177.7	189.6	162.6	165.7	173.6	185.2	158.7	161.8	169.4	180.8	154.8	157.8	165.3	176.4	147.1	149.9	157.0	167.5	136.3	138.9	145.5	155.2	136.3	138.9	145.5	155.2							
		S/T	0.90	0.87	0.79	0.64	0.94	0.90	0.81	0.66	0.96	0.93	0.84	0.68	0.99	0.96	0.86	0.70	1.00	0.99	0.90	0.73	1.00	1.00	0.90	0.73	1.00	1.00	0.90	0.73							
		ΔT	29	28	27	23	29	29	27	23	29	29	27	23	29	29	27	24	28	28	27	23	26	27	25	22	26	27	25	22							
		HI PR	233	251	265	276	262	281	297	310	297	320	338	353	339	365	385	402	381	410	433	452	421	453	479	499	421	453	479	499							
		LO PR	102	109	119	127	108	115	126	134	112	120	131	139	118	126	137	146	124	132	144	153	128	136	149	158	128	136	149	158							

IDB: Entering Indoor Dry Bulb Temperature

Shaded area reflects AHRI (TVA) conditions

High and low pressures are measured at the liquid and suction access fittings.

IDB		OUTDOOR AMBIENT TEMPERATURE																																			
		65						75						85						95						105						115					
		AIRFLOW				ENTERING INDOOR WET BULB TEMPERATURE				ENTERING INDOOR WET BULB TEMPERATURE				ENTERING INDOOR WET BULB TEMPERATURE				ENTERING INDOOR WET BULB TEMPERATURE				ENTERING INDOOR WET BULB TEMPERATURE				ENTERING INDOOR WET BULB TEMPERATURE				ENTERING INDOOR WET BULB TEMPERATURE							
59	63	67	71	59	63	67	71	59	63	67	71	59	63	67	71	59	63	67	71	59	63	67	71	59	63	67	71	59	63	67	71						
70	MBh	235.2	243.8	267.1	-	229.7	238.1	260.9	-	224.2	232.4	254.6	-	218.8	226.8	248.4	-	207.8	215.4	236.0	-	201.8	209.1	229.1	-	186.9	193.7	212.3	-	192.5	199.5	218.6	-				
	S/T	0.76	0.63	0.44	-	0.78	0.66	0.45	-	0.80	0.67	0.47	-	0.83	0.69	0.48	-	0.86	0.72	0.50	-	0.82	0.69	0.48	-	0.83	0.69	0.48	-	0.87	0.73	0.50	-				
	ΔT	21	18	14	-	21	18	14	-	21	18	14	-	21	18	14	-	21	18	14	-	21	18	14	-	20	17	13	-	20	17	13	-				
	HI PR	259	279	294	-	290	313	330	-	330	356	375	-	376	405	428	-	423	456	481	-	419	451	476	-	463	498	526	-	468	503	531	-				
	LO PR	100	106	116	-	105	112	122	-	110	117	127	-	115	122	134	-	121	128	140	-	119	127	139	-	123	131	143	-	125	133	145	-				
75	MBh	228.3	236.7	259.3	-	223.0	231.2	253.3	-	217.7	225.7	247.2	-	212.4	220.1	241.2	-	205.2	211.3	228.7	245.4	190.1	195.7	211.8	227.4	172.5	178.8	195.9	-	195.8	201.6	218.2	234.2				
	S/T	0.72	0.60	0.42	-	0.75	0.63	0.43	-	0.77	0.64	0.44	-	0.79	0.66	0.46	-	0.82	0.69	0.48	-	0.82	0.69	0.48	-	0.80	0.67	0.46	-	0.99	0.88	0.67	0.43				
	ΔT	22	19	14	-	22	19	14	-	22	19	14	-	22	19	15	-	22	19	14	-	22	19	14	-	23	20	15	-	23	21	17	12				
	HI PR	256	276	291	-	288	310	327	-	327	352	372	-	373	401	423	-	419	451	476	-	407	438	462	-	449	483	510	-	472	508	537	560				
	LO PR	99	105	115	-	104	111	121	-	108	115	126	-	114	121	132	-	119	127	139	-	116	123	134	-	120	127	139	-	126	134	146	156				
7875	MBh	210.7	218.4	239.3	-	205.8	213.4	233.8	-	200.9	208.3	228.2	-	196.0	203.2	222.6	-	196.0	203.2	222.6	-	186.2	193.0	211.5	-	172.5	178.8	195.9	-	195.8	201.6	218.2	234.2				
	S/T	0.70	0.58	0.40	-	0.72	0.60	0.42	-	0.74	0.62	0.43	-	0.76	0.64	0.44	-	0.76	0.64	0.44	-	0.79	0.66	0.46	-	0.80	0.67	0.46	-	0.99	0.88	0.67	0.43				
	ΔT	24	21	16	-	24	21	16	-	24	21	16	-	25	21	16	-	25	21	16	-	24	21	16	-	23	20	15	-	23	21	17	12				
	HI PR	249	268	283	-	279	300	317	-	317	341	361	-	361	389	411	-	361	389	411	-	407	438	462	-	449	483	510	-	472	508	537	560				
	LO PR	96	102	111	-	101	108	118	-	105	112	122	-	110	118	128	-	110	118	128	-	116	123	134	-	120	127	139	-	126	134	146	156				
7875	MBh	239.2	246.2	266.5	286.1	233.6	240.5	260.3	279.4	228.0	234.8	254.1	272.8	222.5	229.1	247.9	266.1	216.0	222.4	240.7	258.4	205.2	211.3	228.7	245.4	190.1	195.7	211.8	227.4	195.8	201.6	218.2	234.2				
	S/T	0.86	0.77	0.58	0.37	0.89	0.80	0.60	0.39	0.91	0.82	0.62	0.40	0.94	0.84	0.64	0.41	0.90	0.81	0.61	0.39	0.93	0.84	0.63	0.41	0.94	0.84	0.64	0.41	0.99	0.88	0.67	0.43				
	ΔT	24	22	18	13	24	22	18	13	24	22	18	13	25	23	19	13	26	24	19	13	25	23	19	13	24	22	18	12	23	21	17	12				
	HI PR	262	281	297	310	293	316	333	348	334	359	379	396	380	409	432	451	376	405	428	446	423	456	481	502	468	503	532	554	472	508	537	560				
	LO PR	101	107	117	125	106	113	124	132	111	118	129	137	116	124	135	144	115	122	134	142	121	128	140	149	125	133	145	154	126	134	146	156				
75	MBh	232.2	239.1	258.8	277.7	226.8	233.5	252.8	271.3	221.4	228.0	246.7	264.8	216.0	222.4	240.7	258.4	205.2	211.3	228.7	245.4	190.1	195.7	211.8	227.4	195.8	201.6	218.2	234.2								
	S/T	0.82	0.73	0.56	0.36	0.85	0.76	0.58	0.37	0.87	0.78	0.59	0.38	0.90	0.81	0.61	0.39	0.93	0.84	0.63	0.41	0.94	0.84	0.63	0.41	0.94	0.84	0.64	0.41	0.99	0.88	0.67	0.43				
	ΔT	25	23	19	13	25	23	19	13	25	23	19	13	26	24	19	13	26	24	19	13	25	23	19	13	24	22	18	12	23	21	17	12				
	HI PR	259	279	294	307	291	313	330	344	330	356	376	392	376	405	428	446	423	456	481	502	468	503	532	554	472	508	537	560								
	LO PR	100	106	116	123	105	112	122	130	110	117	127	136	115	122	134	142	121	128	140	149	125	133	145	154	126	134	146	156								
5600	MBh	214.3	220.7	238.8	256.3	209.3	215.5	233.3	250.4	204.4	210.4	227.7	244.4	199.4	205.3	222.2	238.5	189.4	195.0	211.1	226.5	175.4	180.6	195.5	209.8	195.8	201.6	218.2	234.2								
	S/T	0.79	0.71	0.54	0.34	0.82	0.73	0.56	0.36	0.84	0.75	0.57	0.37	0.87	0.78	0.59	0.38	0.90	0.81	0.61	0.39	0.91	0.81	0.62	0.40	0.99	0.88	0.67	0.43								
	ΔT	28	26	21	15	28	26	21	15	28	26	21	15	28	26	21	15	28	26	21	15	26	24	20	14	26	24	20	14								
	HI PR	251	270	285	298	282	303	320	334	321	345	364	380	365	393	415	433	411	442	467	487	454	488	516	538	472	508	537	560								
	LO PR	97	103	112	120	102	109	119	126	106	113	123	131	112	119	130	138	117	124	136	145	121	129	141	150	126	134	146	156								

IDB: Entering Indoor Dry Bulb Temperature

Shaded area reflects ACCA (TVA) conditions

High and low pressures are measured at the liquid and suction access fittings.

IDB		OUTDOOR AMBIENT TEMPERATURE																													
		65					75					85					95					105					115				
		AIRFLOW				ENTERING INDOOR WET BULB TEMPERATURE																									
80	7875	MBh	243.4	248.7	265.7	284.1	237.8	242.9	259.6	277.5	232.1	237.2	253.4	270.9	226.4	231.4	247.2	264.3	215.1	219.8	234.8	251.0	199.3	203.6	217.5	232.5					
		S/T	0.94	0.89	0.72	0.54	1.00	0.92	0.75	0.56	1.00	0.94	0.77	0.57	1.00	1.00	0.79	0.59	1.00	1.00	0.82	0.61	1.00	1.00	0.83	0.62					
		ΔT	27	26	22	18	28	26	23	18	27	26	23	18	26	27	23	18	25	25	26	22	18	23	24	21	17				
		HI PR	264	284	300	313	296	319	337	351	337	363	383	400	384	413	436	455	432	465	491	512	512	477	514	542	566				
		LO PR	102	108	118	126	108	114	125	133	112	119	130	138	117	125	136	145	123	131	143	152	152	127	135	148	157				
		MBh	236.3	241.5	258.0	275.8	230.8	235.9	252.0	269.4	225.3	230.3	246.0	263.0	219.8	224.6	240.0	256.6	208.8	213.4	228.0	243.7	193.5	197.7	211.2	225.8					
	S/T	0.90	0.84	0.69	0.51	0.93	0.88	0.71	0.53	0.96	0.90	0.73	0.55	0.99	0.93	0.75	0.56	1.00	0.96	0.78	0.58	1.00	0.97	0.79	0.59						
	ΔT	28	27	23	19	28	27	24	19	28	27	24	19	29	27	24	19	27	27	23	19	25	25	22	17						
	HI PR	262	281	297	310	293	316	334	348	334	359	379	396	380	409	432	451	428	460	486	507	473	509	537	560						
	LO PR	101	107	117	125	106	113	124	132	111	118	129	137	116	124	135	144	122	130	141	151	126	134	146	156						
	5600	MBh	218.1	222.9	238.1	254.6	213.1	217.7	232.6	248.6	208.0	212.5	227.1	242.7	202.9	207.3	221.5	236.8	192.8	197.0	210.4	225.0	178.6	182.5	194.9	208.4					
		S/T	0.87	0.81	0.66	0.50	0.90	0.84	0.69	0.51	0.92	0.87	0.70	0.53	0.95	0.89	0.73	0.54	0.99	0.93	0.75	0.56	1.00	0.93	0.76	0.57					
ΔT		31	30	26	21	31	30	26	21	32	30	26	21	32	30	26	21	31	30	26	21	29	28	24	19						
HI PR		254	273	288	301	285	306	323	337	324	348	368	384	369	397	419	437	415	446	471	492	458	493	521	543						
LO PR		98	104	114	121	103	110	120	128	107	114	125	133	113	120	131	139	118	126	137	146	122	130	142	151						
MBh		247.7	252.5	264.4	282.1	241.9	246.6	258.3	275.5	236.2	240.7	252.1	269.0	230.4	234.8	246.0	262.4	218.9	223.1	233.7	249.3	202.7	206.7	216.4	230.9						
85	7875	S/T	0.99	0.96	0.86	0.70	1.00	0.99	0.89	0.72	1.00	1.00	0.92	0.74	1.00	1.00	0.95	0.77	1.00	1.00	0.98	0.80	1.00	1.00	0.99	0.80					
		ΔT	29	28	27	23	28	28	27	23	28	28	27	23	27	27	27	24	26	26	27	23	24	24	25	22					
		HI PR	267	287	303	316	299	322	340	355	340	366	387	404	388	417	441	460	436	469	496	517	482	519	548	571					
		LO PR	103	109	119	127	109	116	126	134	113	120	131	140	119	126	138	147	124	132	144	154	129	137	149	159					
		MBh	240.5	245.1	256.7	273.9	234.9	239.4	250.7	267.5	229.3	233.7	244.8	261.1	223.7	228.0	238.8	254.8	212.5	216.6	226.9	242.0	196.8	200.6	210.1	224.2					
		S/T	0.94	0.91	0.82	0.67	0.98	0.94	0.85	0.69	1.00	0.97	0.87	0.71	1.00	1.00	0.90	0.73	1.00	1.00	0.94	0.76	1.00	1.00	0.94	0.77					
	5600	ΔT	30	29	28	24	30	30	28	24	30	30	28	24	29	30	28	24	28	28	28	24	26	26	26	23					
		HI PR	264	284	300	313	296	319	337	351	337	363	383	400	384	413	436	455	432	465	491	512	477	514	542	566					
		LO PR	102	108	118	126	108	114	125	133	112	119	130	138	117	125	136	145	123	131	143	152	127	135	148	157					
		MBh	221.9	226.2	236.9	252.8	216.8	221.0	231.4	246.9	211.6	215.7	225.9	241.0	206.5	210.5	220.4	235.1	196.1	199.9	209.4	223.4	180.7	185.2	194.0	206.9					
		S/T	0.91	0.88	0.79	0.64	0.94	0.91	0.82	0.67	0.97	0.93	0.84	0.68	1.00	0.96	0.87	0.71	1.00	1.00	0.90	0.73	1.00	1.00	0.91	0.74					
		ΔT	33	33	31	27	34	33	31	27	34	33	31	27	34	33	31	27	32	33	31	27	30	30	29	25					
HI PR	256	276	291	304	288	309	327	341	327	352	372	388	372	401	423	441	419	451	476	497	463	498	526	549							
LO PR	99	105	115	122	104	111	121	129	108	115	126	134	114	121	132	141	119	127	139	148	123	131	143	153							

IDB: Entering Indoor Dry Bulb Temperature
 Shaded area reflects AHRI (TVA) conditions
 High and low pressures are measured at the liquid and suction access fittings.

IDB		OUTDOOR AMBIENT TEMPERATURE																								
		65				75				85				95				105				115				
		59	63	67	71	59	63	67	71	59	63	67	71	59	63	67	71	59	63	67	71	59	63	67	71	
		ENTERING INDOOR WET BULB TEMPERATURE																								
AIRFLOW		MBh	284.2	294.5	322.7	-	277.6	287.7	315.2	-	271.0	280.8	307.7	-	264.3	274.0	300.2	-	251.1	260.3	285.2	-	232.6	241.1	264.2	-
		S/T	0.67	0.56	0.39	-	0.70	0.58	0.40	-	0.72	0.60	0.41	-	0.74	0.62	0.43	-	0.77	0.64	0.44	-	0.77	0.65	0.45	-
9202		ΔT	19	17	13	-	19	17	13	-	19	17	13	-	19	17	13	-	19	17	13	-	18	16	12	-
		KW	22.18	22.65	23.36	-	23.88	24.39	25.17	-	25.38	25.93	26.77	-	26.70	27.29	28.19	-	27.83	28.45	29.39	-	28.80	29.44	30.43	-
		HI PR	270	290	306	-	303	326	344	-	344	370	391	-	392	422	445	-	441	475	501	-	487	524	554	-
		LO PR	102	108	118	-	108	115	125	-	112	119	130	-	118	125	137	-	123	131	143	-	127	136	148	-
		MBh	275.9	286.0	313.3	-	269.5	279.3	306.0	-	263.1	272.7	298.7	-	256.7	266.0	291.5	-	243.8	252.7	276.9	-	225.9	234.1	256.5	-
70		S/T	0.64	0.54	0.37	-	0.67	0.56	0.38	-	0.68	0.57	0.39	-	0.70	0.59	0.41	-	0.73	0.61	0.42	-	0.74	0.62	0.43	-
		ΔT	20	17	13	-	20	17	13	-	20	17	13	-	20	18	13	-	20	17	13	-	19	16	12	-
		KW	22.00	22.47	23.17	-	23.69	24.20	24.97	-	25.17	25.72	26.55	-	26.48	27.07	27.95	-	27.60	28.21	29.14	-	28.56	29.20	30.17	-
		HI PR	267	287	303	-	300	322	340	-	341	367	387	-	388	418	441	-	437	470	496	-	482	519	548	-
		LO PR	101	107	117	-	107	113	124	-	111	118	129	-	116	124	135	-	122	130	142	-	126	134	147	-
		MBh	262.1	271.7	297.6	-	256.0	265.3	290.7	-	249.9	259.0	283.8	-	243.8	252.7	276.9	-	231.6	240.1	263.0	-	214.6	222.4	243.7	-
7257		S/T	0.61	0.51	0.36	-	0.64	0.53	0.37	-	0.65	0.55	0.38	-	0.67	0.56	0.39	-	0.70	0.58	0.40	-	0.71	0.59	0.41	-
		ΔT	20	18	13	-	21	18	14	-	21	18	14	-	21	18	14	-	21	18	13	-	19	17	13	-
		KW	21.66	22.11	22.80	-	23.31	23.80	24.56	-	24.76	25.30	26.12	-	26.05	26.62	27.49	-	27.14	27.74	28.65	-	28.08	28.71	29.66	-
		HI PR	262	282	297	-	294	316	334	-	334	359	379	-	380	409	432	-	428	460	486	-	473	509	537	-
		LO PR	99	105	115	-	105	111	121	-	109	116	126	-	114	121	133	-	120	127	139	-	124	132	144	-
		MBh	289.0	297.5	322.1	345.7	282.3	290.6	314.6	337.6	275.6	283.7	307.1	329.6	268.8	276.8	299.6	321.5	255.4	262.9	284.6	305.5	236.6	243.6	263.6	283.0
9202		S/T	0.76	0.68	0.52	0.3	0.79	0.71	0.54	0.3	0.81	0.73	0.55	0.4	0.84	0.75	0.57	0.4	0.87	0.78	0.59	0.4	0.88	0.79	0.59	0.4
		ΔT	22	20	17	12	22	21	17	12	22	21	17	12	23	21	17	12	22	20	17	12	21	19	16	10.8
		KW	22.36	22.83	23.55	24.3	24.07	24.59	25.38	26.2	25.59	26.15	27.00	27.9	26.93	27.52	28.43	29.4	28.07	28.69	29.64	30.6	29.05	29.70	30.69	31.7
		HI PR	272	293	310	322.9	306	329	347	362.3	348	374	395	412.0	396	426	450	469.3	445	479	506	528.0	492	530	559	583.3
		LO PR	103	110	120	127.4	109	116	126	134.6	113	120	131	139.9	119	126	138	147.0	125	132	145	154.0	129	137	150	159.3
		MBh	280.6	288.9	312.7	335.6	274.1	282.2	305.4	327.8	267.5	275.4	298.1	320.0	261.0	268.7	290.9	312.2	248.0	255.3	276.3	296.6	229.7	236.5	256.0	274.7
75		S/T	0.73	0.65	0.49	0.3	0.76	0.68	0.51	0.3	0.78	0.69	0.52	0.3	0.80	0.72	0.54	0.3	0.83	0.74	0.56	0.4	0.84	0.75	0.57	0.4
		ΔT	23	21	17	12	23	21	18	12	23	21	18	12	23	22	18	12	23	21	17	12	22	20	16	11.2
		KW	22.18	22.65	23.36	24.1	23.88	24.40	25.18	26.0	25.38	25.94	26.78	27.7	26.71	27.30	28.19	29.1	27.83	28.45	29.39	30.4	28.80	29.45	30.43	31.5
		HI PR	270	290	307	319.7	303	326	344	358.7	344	370	391	408.0	392	422	446	464.7	441	475	501	522.7	487	524	554	577.6
		LO PR	102	108	118	126.1	108	115	125	133.3	112	119	130	138.5	118	125	137	145.5	123	131	143	152.5	128	136	148	157.7
		MBh	266.5	274.4	297.1	318.8	260.3	268.1	290.1	311.4	254.1	261.7	283.2	304.0	248.0	255.3	276.3	296.6	235.6	242.5	262.5	281.7	218.2	224.7	243.2	261.0
7257		S/T	0.70	0.63	0.47	0.3	0.72	0.65	0.49	0.3	0.74	0.66	0.50	0.3	0.77	0.69	0.52	0.3	0.80	0.71	0.54	0.3	0.80	0.72	0.54	0.3
		ΔT	24	22	18	12	24	22	18	12	24	22	18	12	24	22	18	13	24	22	18	12	22	20	17	11.6
		KW	21.83	22.29	22.99	23.7	23.50	24.00	24.77	25.6	24.97	25.51	26.34	27.2	26.27	26.84	27.72	28.6	27.37	27.98	28.90	29.9	28.32	28.95	29.91	30.9
		HI PR	264	284	300	313.3	297	319	337	351.5	337	363	383	399.8	384	413	437	455.4	432	465	491	512.3	478	514	543	566.0
		LO PR	100	106	116	123.6	106	112	123	130.6	110	117	127	135.7	115	123	134	142.6	121	129	140	149.4	125	133	145	154.6

IDB: Entering Indoor Dry Bulb Temperature
 High and low pressures are measured at the liquid and suction access fittings.
 Shaded area reflects ACCA (TVA) Rating Conditions.
 Design Subcooling, 16 - 19 °F @ the liquid access fitting connection ARI 95 test conditions. Design Superheat 8 - 12°F @ the compressor suction access fitting connection.
 Amps: Unit amps (comp.+ evaporator + condenser fan motors)
 kW = Total system power

IDB		OUTDOOR AMBIENT TEMPERATURE																																
		65					75					85					95					105					115							
		59	63	67	71	75	59	63	67	71	75	59	63	67	71	75	59	63	67	71	75	59	63	67	71	75	59	63	67	71	75			
ENTERING INDOOR WET BULB TEMPERATURE																																		
80	9202	MBh	294.1	300.6	321.1	343.3	287.3	293.6	313.6	335.3	280.4	286.6	306.2	327.3	273.6	279.6	298.7	319.3	259.9	265.6	283.8	303.3	240.8	246.0	262.9	281.0	215.4	221.1	237.3	253.9	190.9	197.1	212.8	228.9
	S/T	0.84	0.79	0.64	0.5	0.87	0.82	0.66	0.5	0.89	0.84	0.68	0.5	0.92	0.86	0.70	0.5	0.92	0.86	0.70	0.5	0.96	0.90	0.73	0.5	0.96	0.90	0.74	0.5	0.96	0.90	0.74	0.5	
	ΔT	25	24	21	16	25	24	21	17	25	24	21	17	25	24	21	17	25	24	21	17	25	24	21	17	23	22	19	15.4	23	22	19	15.4	
	KW	22.54	23.01	23.74	24.5	24.27	24.79	25.59	26.4	25.80	26.37	27.23	28.1	27.15	27.75	28.67	29.6	28.30	28.93	29.89	30.9	29.29	29.95	30.95	32.0	29.29	29.95	30.95	32.0	29.29	29.95	30.95	32.0	
	HI PR	275	296	313	326.1	309	332	351	366.0	351	378	399	416.2	400	430	455	474.0	450	484	511	533.3	497	535	565	589.2	497	535	565	589.2	497	535	565	589.2	
LO PR	104	111	121	128.7	110	117	128	136.0	114	122	133	141.3	120	128	139	148.4	126	134	146	155.6	130	138	151	160.9	130	138	151	160.9	130	138	151	160.9		
8200	MBh	285.6	291.8	311.8	333.3	278.9	285.0	304.5	325.5	272.3	278.2	297.3	317.8	265.6	271.4	290.0	310.0	252.4	257.9	275.5	294.5	233.8	238.9	255.2	272.8	215.4	221.1	237.3	253.9	190.9	197.1	212.8	228.9	
	S/T	0.80	0.75	0.61	0.5	0.83	0.78	0.63	0.5	0.85	0.80	0.65	0.5	0.88	0.82	0.67	0.5	0.88	0.82	0.67	0.5	0.92	0.86	0.70	0.5	0.92	0.86	0.70	0.5	0.92	0.86	0.70	0.5	
	ΔT	26	25	21	17	26	25	22	17	26	25	22	17	26	25	22	17	26	25	22	18	24	23	20	16.0	24	23	20	16.0	24	23	20	16.0	
	KW	22.36	22.83	23.55	24.3	24.08	24.59	25.38	26.2	25.59	26.15	27.00	27.9	26.93	27.53	28.43	29.4	28.07	28.69	29.64	30.6	29.05	29.70	30.69	31.7	29.05	29.70	30.69	31.7	29.05	29.70	30.69	31.7	
	HI PR	272	293	310	322.9	306	329	347	362.3	348	374	395	412.1	396	426	450	469.4	446	479	506	528.0	492	530	559	583.4	492	530	559	583.4	492	530	559	583.4	
LO PR	103	110	120	127.4	109	116	126	134.6	113	120	131	139.9	119	126	138	147.0	125	132	145	154.0	129	137	150	159.3	129	137	150	159.3	129	137	150	159.3		
7257	MBh	271.3	277.2	296.2	316.6	265.0	270.8	289.3	309.2	258.7	264.3	282.4	301.9	252.4	257.9	275.5	294.5	239.7	245.0	261.7	279.8	222.1	226.9	242.4	259.2	203.6	209.4	225.1	241.8	185.1	191.9	207.6	224.3	
	S/T	0.77	0.72	0.59	0.4	0.79	0.74	0.61	0.5	0.81	0.76	0.62	0.5	0.84	0.79	0.64	0.5	0.84	0.79	0.64	0.5	0.88	0.83	0.67	0.5	0.88	0.83	0.67	0.5	0.88	0.83	0.67	0.5	
	ΔT	26	25	22	18	27	26	22	18	27	26	22	18	27	26	22	18	27	26	22	18	25	24	21	16.5	25	24	21	16.5	25	24	21	16.5	
	KW	22.00	22.47	23.17	23.9	23.69	24.20	24.97	25.8	25.17	25.72	26.55	27.4	26.48	27.07	27.95	28.9	26.48	27.07	27.95	28.9	27.60	28.21	29.14	30.1	28.56	29.20	30.17	31.2	28.56	29.20	30.17	31.2	
	HI PR	267	287	303	316.5	300	322	340	355.1	341	367	387	403.8	388	418	441	460.0	437	470	496	517.5	482	519	548	571.7	482	519	548	571.7	482	519	548	571.7	
LO PR	101	107	117	124.9	107	113	124	131.9	111	118	129	137.1	116	124	135	144.0	122	130	142	150.9	126	134	147	156.1	126	134	147	156.1	126	134	147	156.1		

IDB		OUTDOOR AMBIENT TEMPERATURE																																
		65					75					85					95					105					115							
		59	63	67	71	75	59	63	67	71	75	59	63	67	71	75	59	63	67	71	75	59	63	67	71	75	59	63	67	71	75			
ENTERING INDOOR WET BULB TEMPERATURE																																		
85	9202	MBh	299.3	305.1	319.5	340.9	292.3	298.0	312.1	332.9	285.3	290.9	304.6	325.0	278.4	283.8	297.2	317.1	264.5	269.6	282.3	301.2	245.0	249.7	261.5	279.0	226.5	231.2	242.9	260.4	208.0	213.7	225.4	242.9
	S/T	0.88	0.85	0.77	0.6	0.91	0.88	0.79	0.6	0.93	0.90	0.81	0.7	0.96	0.93	0.84	0.7	0.96	0.93	0.84	0.7	1.00	0.97	0.88	0.7	1.00	0.97	0.88	0.7	1.00	0.97	0.88	0.7	
	ΔT	26	26	24	21	27	26	25	21	27	26	25	21	27	26	25	22	27	26	25	21	24	24	23	19.9	24	24	23	19.9	24	24	23	19.9	
	KW	22.72	23.20	23.93	24.7	24.47	25.00	25.80	26.6	26.01	26.58	27.45	28.4	27.38	27.99	28.91	29.9	28.54	29.18	30.15	31.2	29.54	30.20	31.21	32.3	29.54	30.20	31.21	32.3	29.54	30.20	31.21	32.3	
	HI PR	278	299	316	329.4	312	336	354	369.6	355	382	403	420.4	404	435	459	478.8	454	489	516	538.6	502	540	571	595.1	502	540	571	595.1	502	540	571	595.1	
LO PR	105	112	122	130.0	111	118	129	137.3	115	123	134	142.7	121	129	141	149.9	127	135	148	157.1	131	140	153	162.5	131	140	153	162.5	131	140	153	162.5		
8200	MBh	290.6	296.2	310.2	330.9	283.8	289.3	303.0	323.2	277.0	282.4	295.8	315.5	270.3	275.5	288.6	307.8	256.8	261.7	274.1	292.4	237.8	242.5	253.9	270.9	219.3	224.0	235.4	252.4	200.8	206.5	217.9	234.8	
	S/T	0.84	0.81	0.73	0.6	0.87	0.84	0.76	0.6	0.89	0.86	0.78	0.6	0.92	0.89	0.80	0.7	0.92	0.89	0.80	0.7	0.96	0.92	0.83	0.7	0.96	0.92	0.83	0.7	0.96	0.92	0.83	0.7	
	ΔT	27	27	25	22	28	27	26	22	28	27	26	22	28	27	26	22	28	27	26	22	26	25	24	20.7	26	25	24	20.7	26	25	24	20.7	
	KW	22.54	23.01	23.74	24.5	24.27	24.79	25.59	26.4	25.80	26.37	27.23	28.1	27.15	27.75	28.67	29.6	28.30	28.93	29.89	30.9	29.29	29.95	30.95	32.0	29.29	29.95	30.95	32.0	29.29	29.95	30.95	32.0	
	HI PR	275	296	313	326.1	309	332	351	366.0	351	378	399	416.2	400	430	455	474.0	450	484	511	533.3	497	535	565	589.2	497	535	565	589.2	497	535	565	589.2	
LO PR	104	111	121	128.7	110	117	128	136.0	114	122	133	141.3	120	128	139	148.4	126	134	146	155.6	130	138	151	160.9	130	138	151	160.9	130	138	151	160.9		
7257	MBh	276.0	281.4	294.7	314.4	269.6	274.8	287.8	307.1	263.2	268.3	281.0	299.8	256.8	261.7	274.1	292.4	243.9	248.6	260.4	277.8	226.0	230.3	241.2	257.4	207.5	212.2	223.1	239.7	189.0	193.7	204.6	221.2	
	S/T	0.80	0.78	0.70	0.6	0.83	0.80	0.73	0.6	0.85	0.82	0.74	0.6	0.88	0.85	0.77	0.6	0.91	0.88	0.80	0.6	0.92	0.89	0.80	0.7	0.92	0.89	0.80	0.7	0.92	0.89	0.80	0.7	
	ΔT	28	28	26	23	28	28	26	23	28	28	26	23	29	28	27	23	28	28	26	23	26	26	25	21.3	26	26	25	21.3	26	26	25	21.3	
	KW	22.18	22.65	23.36	24.1	23.88	24.39	25.17	26.0	25.38	25.93	26.77	27.7	26.70	27.29	28.19	29.1	27.83	28.45	29.39	30.4	28.80	29.44	30.43	31.5	28.80	29.44	30.43	31.5	28.80	29.44	30.43	31.5	
	HI PR	270	290	306	319.6	303	326	344	358.6	344	370	391	407.9	392	422	445	464.6	441	475	501	522.6	487	524	554	577.5	487	524	554	577.5	487	524	554	577.5	
LO PR	102	108	118	126.1	108	115	125	133.3	112	119	130	138.5	118	125	137	145.5	123	131	143	152.5	127	136	148	157.7	127	136	148	157.7	127	136	148	157.7		

IDB: Entering Indoor Dry Bulb Temperature
 High and low pressures are measured at the liquid and suction access fittings.
 Design Subcooling, 16 - 19°F @ the liquid access fitting connection ARI 95 test conditions. Design Superheat 8 - 12°F @ the compressor suction access fitting connection.
 Shaded area reflects AHRI Rating Conditions.
 Amperage: Unit amps (comp.+ evaporator + condenser fan motors)
 kW = Total system power

STANDARD & TWO-SPEED BELT DRIVE AT HIGH SPEED — DOWN SHOT

ESP (" H ₂ O)	TURNS OPEN													
	0		1		2		3		4		5		6	
	CFM	BHP	CFM	BHP	CFM	BHP	CFM	BHP	CFM	BHP	CFM	BHP	CFM	BHP
0.2	---	---	---	---	---	---	---	---	---	---	7203	2.18	6718	1.84
0.4	---	---	---	---	---	---	7306	2.54	6777	2.14	6257	1.80	5711	1.48
0.6	---	---	7477	2.97	6899	2.51	6323	2.10	5716	1.72	5103	1.39	---	---
0.8	7112	2.96	6467	2.46	5795	2.01	5101	1.61	---	---	---	---	---	---
1.0	5983	2.38	5190	1.89	---	---	---	---	---	---	---	---	---	---
1.2	4426	1.71	---	---	---	---	---	---	---	---	---	---	---	---

HIGH-STATIC BELT DRIVE — DOWN SHOT

ESP (" H ₂ O)	TURNS OPEN													
	0		1		2		3		4		5		6	
	CFM	BHP	CFM	BHP	CFM	BHP	CFM	BHP	CFM	BHP	CFM	BHP	CFM	BHP
1.0	---	---	---	---	---	---	---	---	---	---	7120	3.26	6223	2.55
1.2	---	---	---	---	---	---	---	---	6927	3.39	5924	2.61	---	---
1.4	---	---	---	---	---	---	6739	3.52	5602	2.65	---	---	---	---
1.6	---	---	---	---	6587	3.69	5245	2.67	---	---	---	---	---	---
1.8	---	---	6419	3.84	4877	2.70	---	---	---	---	---	---	---	---
2.0	6261	4.01	---	---	---	---	---	---	---	---	---	---	---	---

STANDARD & TWO-SPEED BELT DRIVE AT HIGH SPEED — DOWN SHOT

ESP (" H ₂ O)	TURNS OPEN													
	0		1		2		3		4		5		6	
	CFM	BHP	CFM	BHP	CFM	BHP	CFM	BHP	CFM	BHP	CFM	BHP	CFM	BHP
0.2	---	---	---	---	---	---	---	---	---	---	---	---	9664	4.05
0.4	---	---	---	---	---	---	---	---	9570	4.08	9197	3.82	8702	3.51
0.6	---	---	---	---	---	---	9038	3.82	8460	3.46	7949	3.14	---	---
0.8	---	---	8171	2.93	7630	3.70	7068	2.79	---	---	---	---	---	---
1.0	---	---	7901	2.85	7203	3.42	---	---	---	---	---	---	---	---
1.2	7344	4.35	---	---	---	---	---	---	---	---	---	---	---	---

HIGH-STATIC BELT DRIVE — DOWN SHOT

ESP (" H ₂ O)	TURNS OPEN													
	0		1		2		3		4		5		6	
	CFM	BHP	CFM	BHP	CFM	BHP	CFM	BHP	CFM	BHP	CFM	BHP	CFM	BHP
1.0	---	---	---	---	---	---	---	---	9090	5.79	8297	5.06	7479	3.62
1.2	---	---	---	---	---	---	8774	5.60	7914	4.83	6989	4.07	---	---
1.4	---	---	---	---	8471	5.43	7549	4.63	---	---	---	---	---	---
1.6	---	---	8209	6.14	7194	4.45	---	---	---	---	---	---	---	---
1.8	7967	6.02	6883	5.01	---	---	---	---	---	---	---	---	---	---
2.0	6594	4.87	---	---	---	---	---	---	---	---	---	---	---	---

NOTES

- Airflow table represent dry coil with filters installed; SCFM correction factor for wet coil is 4%.
- Any adjustment made to the blower should not cause the motor to draw more than the motor rated RLA. Minimum rated SCFM is 350 per ton.
- Unit factory shipped with the sheave set at 2.5 turns open.

STANDARD & TWO-SPEED BELT DRIVE AT HIGH SPEED - DOWN SHOT

Turns Open	0		1		2		3		4		5		6	
RPM	972		941		910		877		845		813		781	
ESP	SCFM	BHP	SCFM	BHP	SCFM	BHP	SCFM	BHP	SCFM	BHP	SCFM	BHP	SCFM	BHP
0.2	---	---	---	---	---	---	10,369	5.07	9,748	4.41	9,191	3.82	8,683	3.28
0.4	---	---	10,802	6.00	10,125	5.30	9,484	4.62	8,905	4.01	8,386	3.46	7,913	2.95
0.6	10,519	6.20	9,821	5.47	9,193	4.81	8,599	4.18	8,062	3.61	7,582	3.10	7,143	2.63
0.8	9,482	5.60	8,839	4.93	8,261	4.32	7,714	3.74	7,220	3.21	6,777	2.74	---	---
1	8,446	5.01	7,857	4.39	7,329	3.83	6,829	3.30	---	---	---	---	---	---
1.2	7,409	4.41	6,876	3.85	---	---	---	---	---	---	---	---	---	---

HIGH STATIC BELT DRIVE

Turns Open	0		1		2		3		4		5		6	
RPM	1254		1208		1163		1124		1085		1046		1007	
ESP	SCFM	BHP	SCFM	BHP	SCFM	BHP	SCFM	BHP	SCFM	BHP	SCFM	BHP	SCFM	BHP
0.6	---	---	---	---	---	---	---	---	---	---	---	---	11,409	7.12
0.8	---	---	---	---	---	---	---	---	---	---	---	---	10,302	6.46
1	---	---	---	---	---	---	---	---	---	---	10,159	6.79	9,195	5.79
1.2	---	---	---	---	---	---	---	---	9,990	7.11	8,961	6.04	8,087	5.13
1.4	---	---	---	---	---	---	9,789	7.39	8,686	6.25	7,763	5.29	6,980	4.46
1.6	---	---	---	---	9,543	7.63	8,357	6.40	7,382	5.39	6,566	4.53	---	---
1.8	---	---	---	---	7,957	6.48	6,925	5.41	6,077	4.53	---	---	---	---
2	---	---	7,667	6.68	6,370	5.34	---	---	---	---	---	---	---	---
2.2	7,280	6.78	---	---	---	---	---	---	---	---	---	---	---	---

NOTES

- Airflow table represent dry coil with filters installed; SCFM correction factor for wet coil is 4%.
- Any adjustment made to the blower should not cause the motor to draw more than the motor rated RLA. Minimum rated SCFM is 350 per ton.
- Unit factory shipped with the sheave set at 2.5 turns open.

AIRFLOW PRESSURE DROP OF DOWNFLOW ECONOMIZER FOR 15- TO 25-TON ROOFTOP UNITS (100% RETURN AIR)

CFM	4,500	5,000	5,500	6,000	6,500	7,000	7,500	8,000	8,500	9,000	9,500	10,000
(In. WG)	0.15	0.18	0.22	0.27	0.32	0.37	0.42	0.48	0.55	0.61	0.69	0.76

THREE-PHASE UNITS @ 208 / 240V – 15 TONS

MODEL	MCA ¹	MOP ²	ACTUAL kW @ 240V	RECOMMENDED AIRFLOW RANGE
DCC180***3B/V				
EHK3-31	98	100	28.8	5250 - 6750 CFM
EHK3-46	141	150	43.2	5250 - 6750 CFM
EHK3-60	185	200	57.6	5250 - 6750 CFM

THREE-PHASE UNITS @ 480-VOLT – 15 TONS

MODEL	MCA ¹	MOP ²	ACTUAL kW @ 480V	RECOMMENDED AIRFLOW RANGE
DCC180***4B/V				
EHK4-31	49	50	28.8	5250 - 6750 CFM
EHK4-46	71	80	43.2	5250 - 6750 CFM
EHK4-60	92	100	57.6	5250 - 6750 CFM

THREE-PHASE UNITS @ 575V – 15 TONS

MODEL	MCA ¹	MOP ²	ACTUAL kW @ 575V	RECOMMENDED AIRFLOW RANGE
DCC180***7B/V				
EHK7-31	41	45	28.8	5250 - 6750 CFM
EHK7-46	59	60	43.2	5250 - 6750 CFM
EHK7-60	78	80	57.6	5250 - 6750 CFM

¹ Maximum Circuit Ampacity

² Maximum Overcurrent Protection (Amps)

Note: When using electric heat kit, the single-point kit installed in the unit is needed to meet UL requirements.

THREE-PHASE UNITS @ 208 / 240V – 25 TONS

MODEL	MCA	MOP	ACTUAL kW @ 240V	AIRFLOW RANGE
DCC300***3B				
EHK3-31	137.6	175	28.8	7200 - 8500 CFM
EHK3-46	155.4	175	43.2	7200 - 8500 CFM
EHK3-60	164.1	175	57.6	7200 - 8500 CFM
EHK3-75	198.7	225	72	7200 - 8500 CFM

THREE-PHASE UNITS @ 480-VOLT – 25 TONS

MODEL	MCA	MOP	ACTUAL kW @ 480V	AIRFLOW RANGE
DCC300***4B				
EHK4-31	55.4	70	28.8	7200 - 8500 CFM
EHK4-46	76.8	80	43.2	7200 - 8500 CFM
EHK4-60	81.1	90	57.6	7200 - 8500 CFM
EHK4-75	98.4	110	72	7200 - 8500 CFM

THREE-PHASE UNITS @ 575V – 25 TONS

MODEL	MCA	MOP	ACTUAL kW @ 575V	AIRFLOW RANGE
DCC300***7B				
EHK7-31	45.5	50	28.8	7200 - 8500 CFM
EHK7-46	63.6	70	43.2	7200 - 8500 CFM
EHK7-60	67.2	80	57.6	7200 - 8500 CFM
EHK7-75	81.7	90	72	7200 - 8500 CFM

THREE-PHASE UNITS @ 208 / 240V – 20 TONS

MODEL	MCA ¹	MOP ²	ACTUAL kW @ 240V	RECOMMENDED AIRFLOW RANGE
DCC240***3B/V				
EHK3-31	103	125	28.8	7200 - 8500 CFM
EHK3-46	146	150	43.2	7200 - 8500 CFM
EHK3-60	189	200	57.6	7200 - 8500 CFM
EHK3-75	232	250	72	7200 - 8500 CFM

480-VOLT UNITS @ 480V – 20 TONS

MODEL	MCA ¹	MOP ²	ACTUAL kW @ 480V	RECOMMENDED AIRFLOW RANGE
DCC240***4B/V				
EHK4-31	51	60	28.8	7200 - 8500 CFM
EHK4-46	73	80	43.2	7200 - 8500 CFM
EHK4-60	95	100	57.6	7200 - 8500 CFM
EHK4-75	116	125	72	7200 - 8500 CFM

575-VOLT UNITS @ 575V – 20 TONS

MODEL	MCA ¹	MOP ²	ACTUAL kW @ 575V	RECOMMENDED AIRFLOW RANGE
DCC240***7B/V				
EHK7-31	43	45	28.8	7200 - 8500 CFM
EHK7-46	61	70	43.2	7200 - 8500 CFM
EHK7-60	79	80	57.6	7200 - 8500 CFM
EHK7-75	97	100	72	7200 - 8500 CFM

¹ Maximum Circuit Ampacity

² Maximum Overcurrent Protection (amps)

Note: When using electric heat kit, the single-point kit installed in the unit is needed to meet UL requirements.

kW CORRECTION FACTORS

kW CORRECTION FACTOR					
SUPPLY VOLTAGE	240	230	220	210	208
CORRECTION FACTOR	1	0.93	0.82	0.78	0.76

kW CORRECTION FACTOR (FOR 480V UNITS)			
SUPPLY VOLTAGE	460	440	430
CORRECTION FACTOR	0.92	0.84	0.8

For other voltage, use $\text{voltage}^2 / 480^2$

kW CORRECTION FACTOR (FOR 575V UNITS)			
SUPPLY VOLTAGE	560	550	540
CORRECTION FACTOR	0.95	0.91	0.88

Multiply rated kW by correction factor to get actual kW.

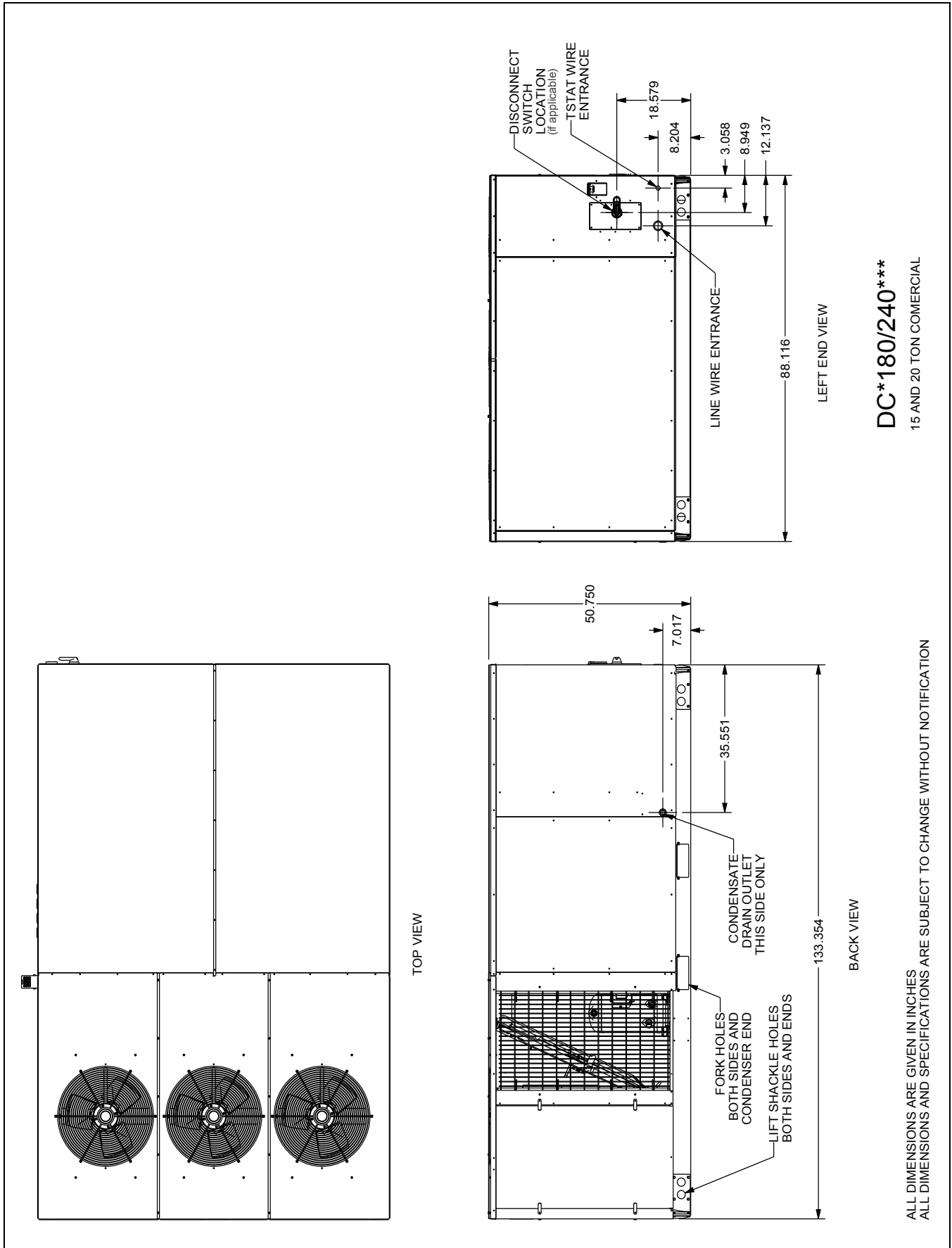

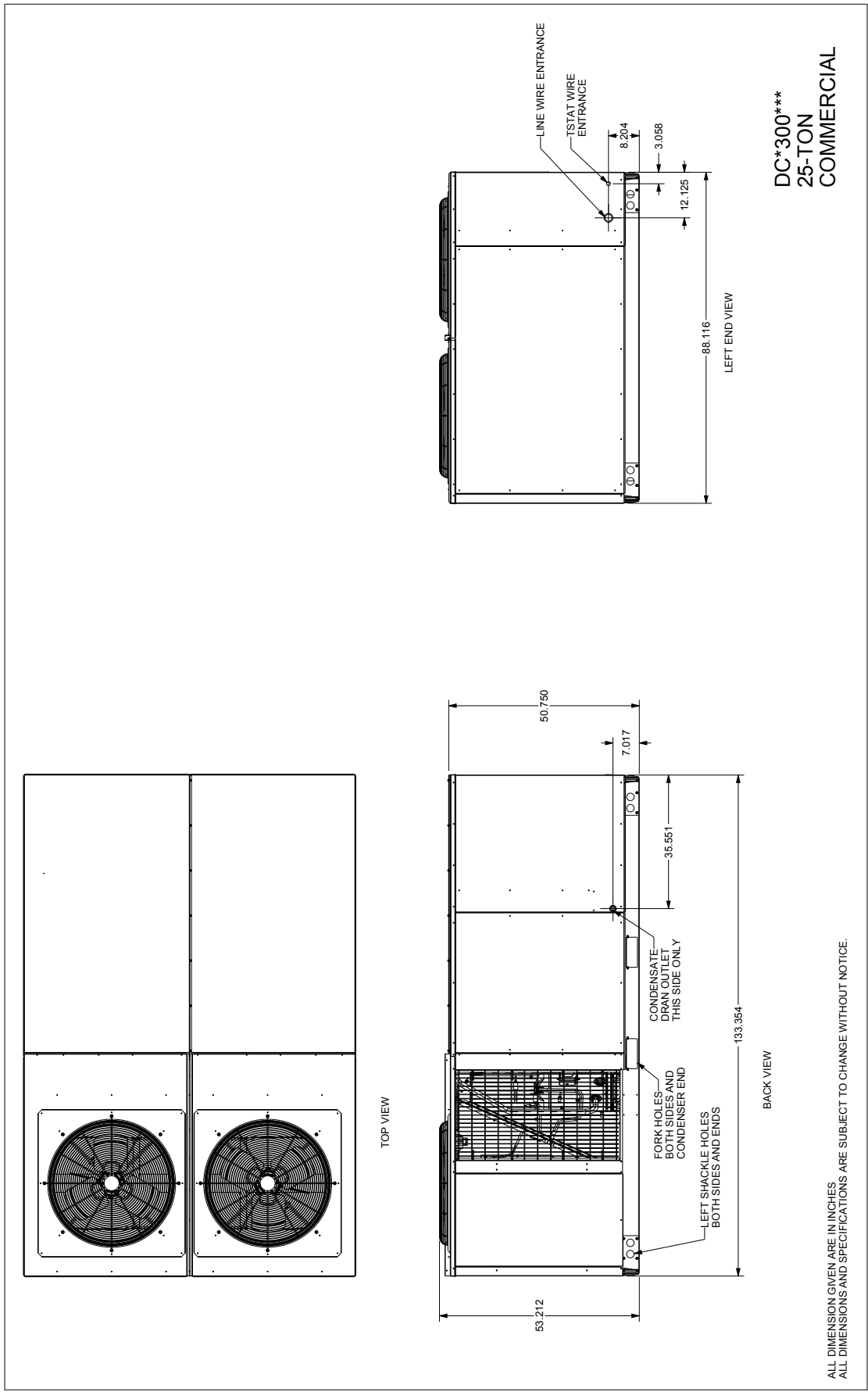

ALL DIMENSION GIVEN ARE IN INCHES
ALL DIMENSIONS AND SPECIFICATIONS ARE SUBJECT TO CHANGE WITHOUT NOTICE.

Maintain an adequate clearance around the unit for safety, service, maintenance, and proper unit operation. Leave a total clearance of 75" on the main control panel side of the unit for possible removal of fan shaft, coil, electric heat, and gas furnace. Leave a clearance of 48" on all other sides of the unit for possible compressor removal or service access, and to ensure proper ventilation and condenser airflow. Do not install the unit beneath any obstruction. Install the unit away from all building exhausts to inhibit Ingestion of exhaust air into the unit's fresh-air intake.

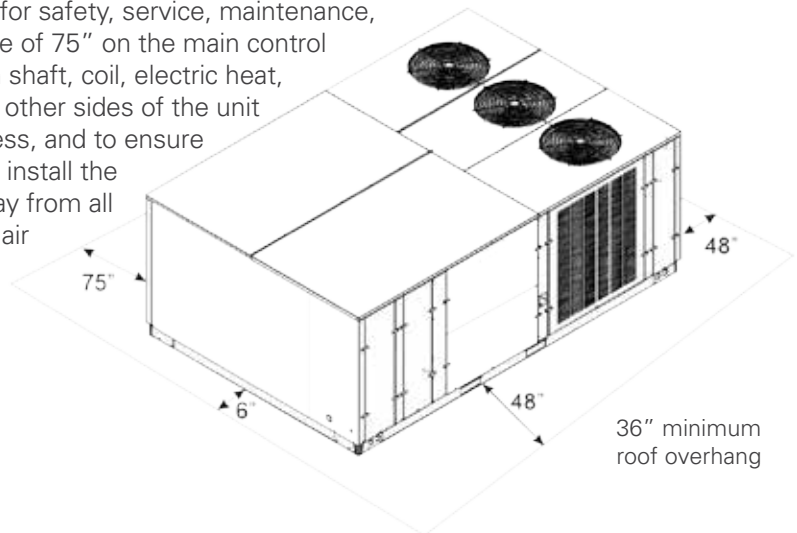

ELECTRICAL ENTRANCE LOCATIONS

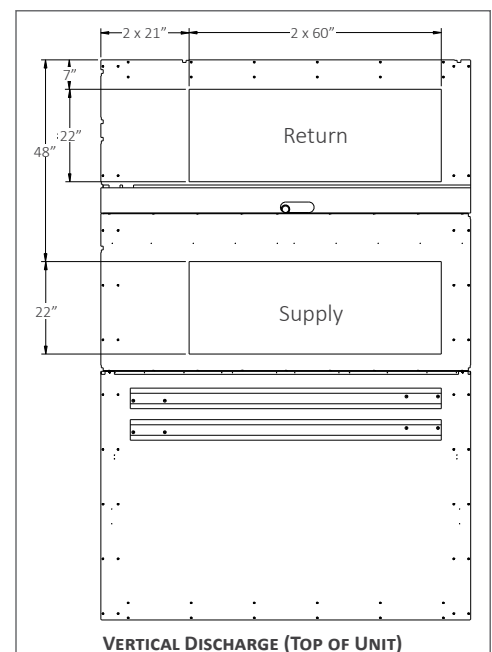
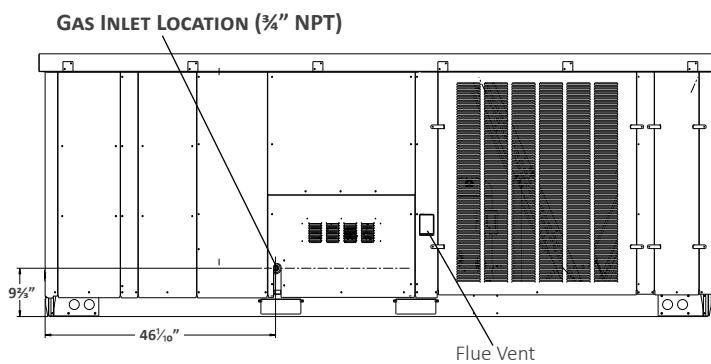
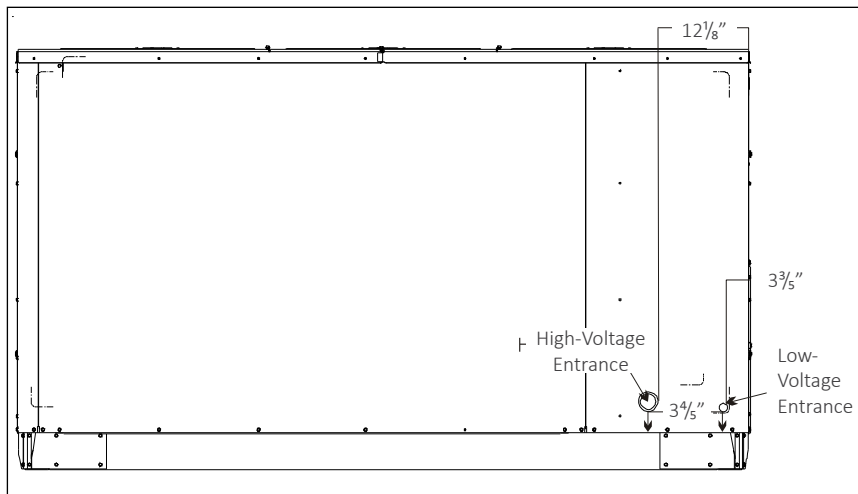

Provisions for forks have been included in the unit base frame. No other fork locations are approved.

- Unit must be lifted by the four lifting holes located at the base frame corners.
- Lifting cables should be attached to the unit with shackles.
- The distance between the crane hook and the top of the unit must not be less than 60".
- Two spreader bars must span over the unit to prevent damage to the cabinet by the lift cables. Spreader bars must be of sufficient length so that cables do not come in contact with the unit during transport. Remove wood struts mounted beneath unit base frame before setting unit on roof curb. These struts are intended to protect unit base frame from fork lift damage. To remove the struts, extract the sheet metal retainers and pull the struts through the base of the unit. Refer to rigging label on the unit.

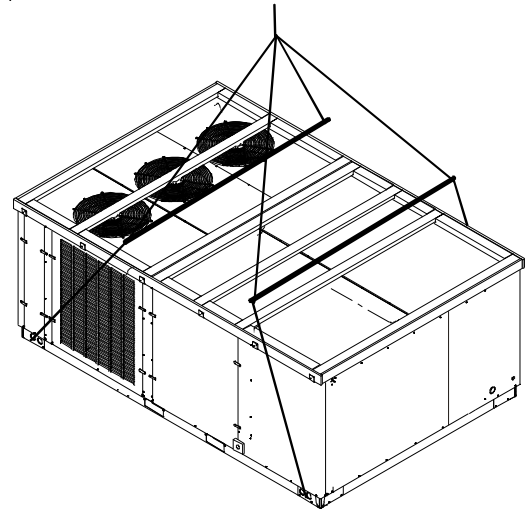

Important: If using bottom discharge with roof curb, duct-work should be attached to the curb prior to installing the unit. Duct-work dimensions are shown in Roof Curb Installation Instructions Manual.

Refer to the Roof Curb Installation Instructions for proper curb installation. Curbing must be installed in compliance with the National Roofing Contractors Association Manual.

Lower unit carefully onto roof mounting curb. While rigging the unit, the center of gravity will cause the condenser end to be lower than the supply air end.

Bring condenser end of unit into alignment with the curb. With condenser end of the unit resting on curb member and using curb as a fulcrum, lower opposite end of the unit until entire unit is seated on the curb. When a rectangular cantilever curb is used, take care to center the unit. Check for proper alignment and orientation of supply and return openings with duct.

To assist in determining rigging requirements, unit weights are shown below.

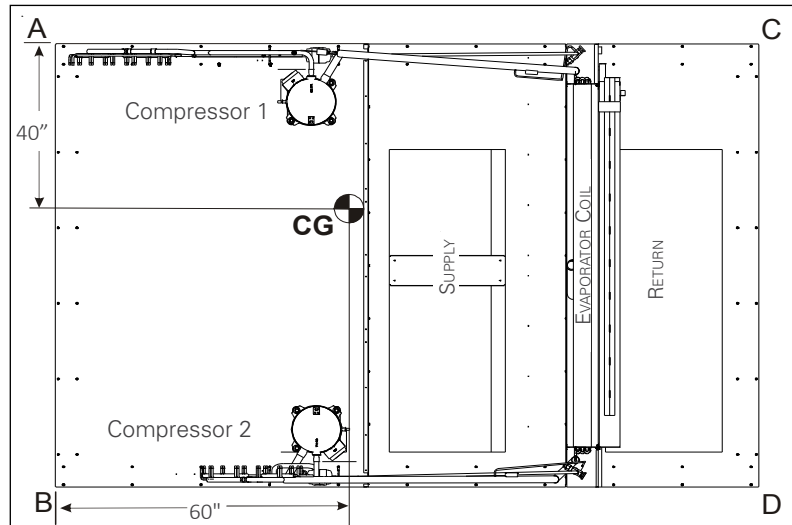

CORNER & CENTER-OF-GRAVITY LOCATIONS

15-TON UNITS	WEIGHTS (LBS.)
Weight A	590
Weight B	482
Weight C	492
Weight D	401
Shipping Weight	2080
Operating Weight	1965

20-TON UNITS	WEIGHTS (LBS.)
Weight A	644
Weight B	525
Weight C	504
Weight D	412
Shipping Weight	2202
Operating Weight	2085

25-TON UNITS	WEIGHTS (LBS.)
Weight A	626
Weight B	464
Weight C	501
Weight D	518
Shipping Weight	2377
Operating Weight	2109

Note: These weights are calculated without installed accessories.

Curb installations must comply with local codes and should follow the established guidelines of the National Roofing Contractors Association.

Proper unit installation requires that the roof curb be firmly and permanently attached to the roof structure. Check for adequate fastening method prior to setting the unit on the curb.

Full perimeter roof curbs are available from the factory and are shipped unassembled. The installing contractor is responsible for field assembly, squaring, leveling, and mounting on the roof structure. All required hardware necessary for the assembly of the sheet metal curb is included in the curb accessory package.

- Determine sufficient structural support before locating and mounting the curb and package unit.
- Duct-work must be constructed using industry guidelines. The duct-work must be placed into the roof curb before mounting the package unit. Our full perimeter curbs include duct connection frames to be assembled with the curb. Cantilevered-type curbs are not available from the factory.
- Contractor furnishes curb insulation, cant strips, flashing, and general roofing material.
- Support curbs on parallel sides with roof members. To prevent damage to the unit, the roof members cannot penetrate supply and return duct openings.

Note: The unit and curb accessories are designed to allow vertical duct installation before unit placement. Duct installation after unit placement is not recommended.

See the manual shipped with the roof curb for assembly and installation instructions.

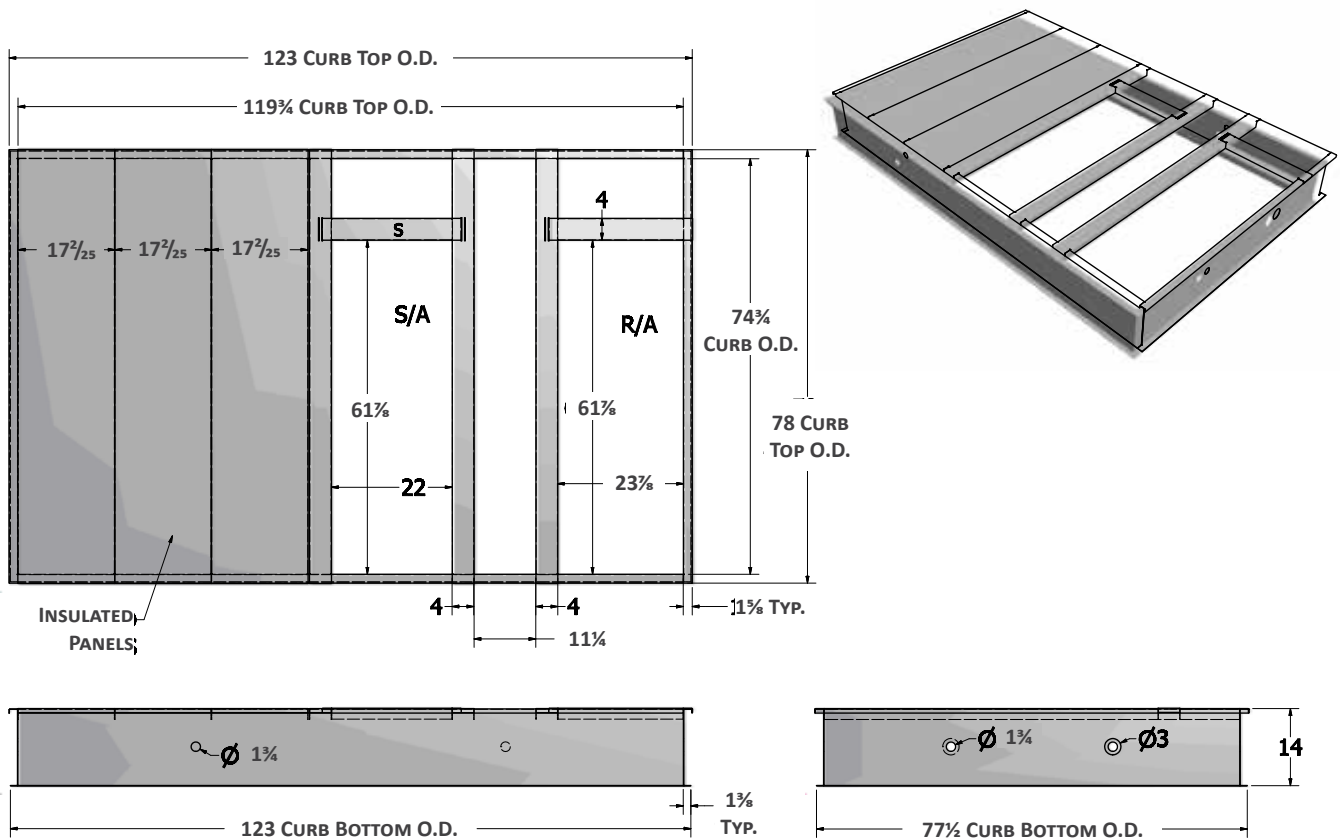

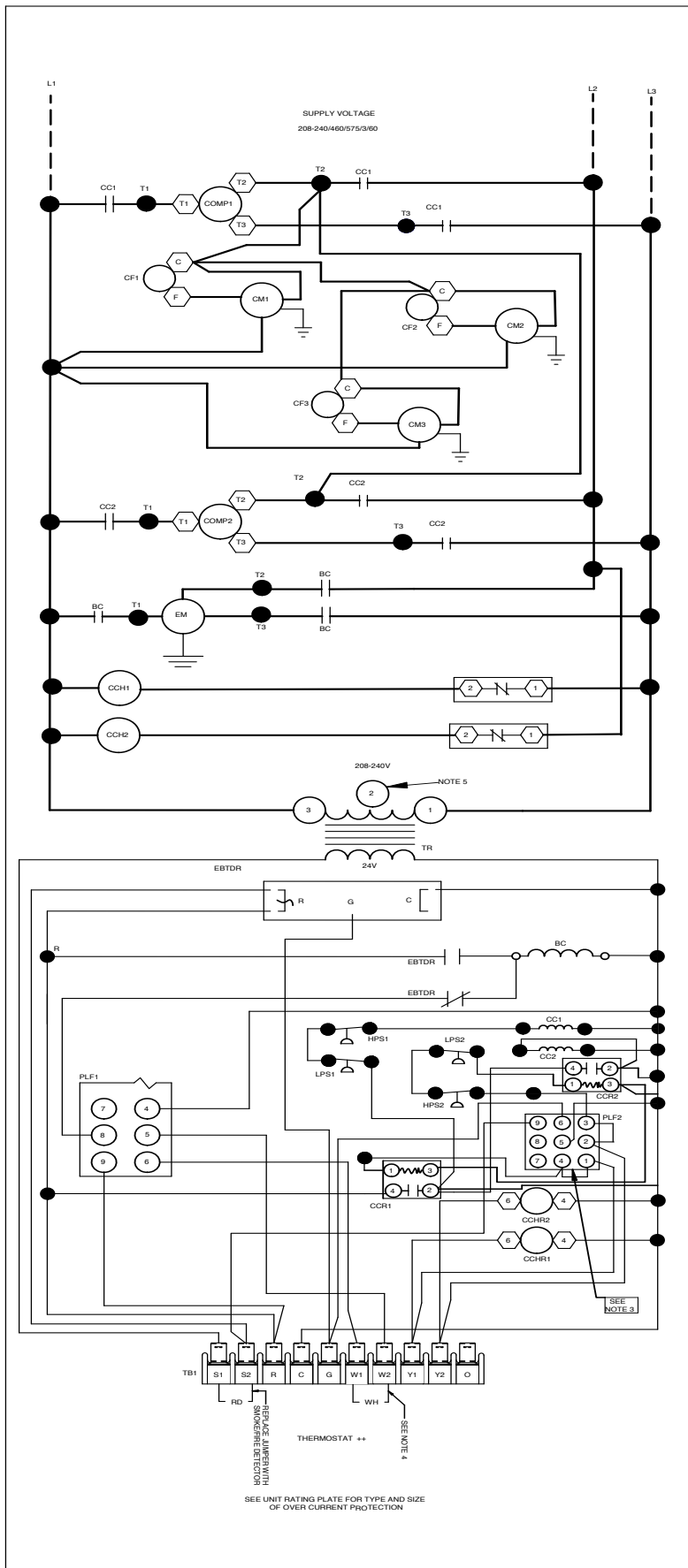

COMPONENT LEGEND

BC	BLOWER CONTACTOR
CC	COMPRESSOR CONTACTOR
CCH	CRANK CASE HEATER
CCHR	CRANK CASE HEATER RELAY
CCR	COMPRESSOR CONTACTOR RELAY
CM	CONDENSER MOTOR
CMR	CONDENSER MOTOR RELAY
COMP	COMPRESSOR
ECON	ECONOMIZER
EBTD	ELECTRONIC BLOWER TIME DELAY
EMR	EVAPORATOR MOTOR RELAY
R	RELAY
EM	EVAPORATOR MOTOR
FC	FAN CAPACITOR
GND	EQUIPMENT GROUND
HPS	HIGH PRESSURE SWITCH
LPS	LOW PRESSURE SWITCH
PB	POWER DISTRIBUTION BLOCK
PLF	FEMALE PLUG / CONNECTOR
TB1	TERMINAL BLOCK (24V SIGNAL)
TB2	TERMINAL BLOCK (L1)
TR	TRANSFORMER

NOTES:

1. REPLACEMENT WIRE MUST BE SAME SIZE AND TYPE INSULATION AS ORIGINAL (AT LEAST 105°C) USE COPPER CONDUCTOR ONLY.
2. USE COPPER CONDUCTORS ONLY
- +++ USE N.E.C. CLASS 2 WIRE
3. ECONOMIZER PLUG LOCATED IN THE RETURN AIR COMPARTMENT. REMOVE MALE PLUG, ATTACH FEMALE PLUG TO THE ECONOMIZER ACCESSORY.
4. FOR TWO STAGE OPERATION REMOVE W1 TO W2 WIRE JUMPER.
5. FOR 208V OPERATION MOVE BLACK WIRE FROM TERMINAL ① TO TERMINAL ② ON 240V TRANSFORMER

FACTORY WIRING

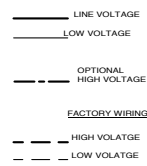

THERMOSTAT ++
FIELD WIRING
2 STAGE COOLING

WIRE CODE

BK	BLACK
BL	BLUE
BR	BROWN
GR	GREEN
OR	ORANGE
PK	PINK
PU	PURPLE
RD	RED
WH	WHITE
YL	YELLOW
YL/PK	YELLOW WITH PINK STRIP
BL/PK	BLUE WITH PINK STRIP

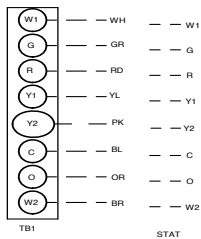

High Voltage: Disconnect all power before servicing or installing this unit. Multiple power sources may be present. Failure to do so may cause property damage, personal injury, or death.



Wiring is subject to change. Always refer to the wiring diagram on the unit for the most up-to-date wiring.



U14ULUC252-A

WIRING DIAGRAM — DCC 15 & 20 TONS (230V/460V/575V, TWO-SPEED BELT DRIVE)

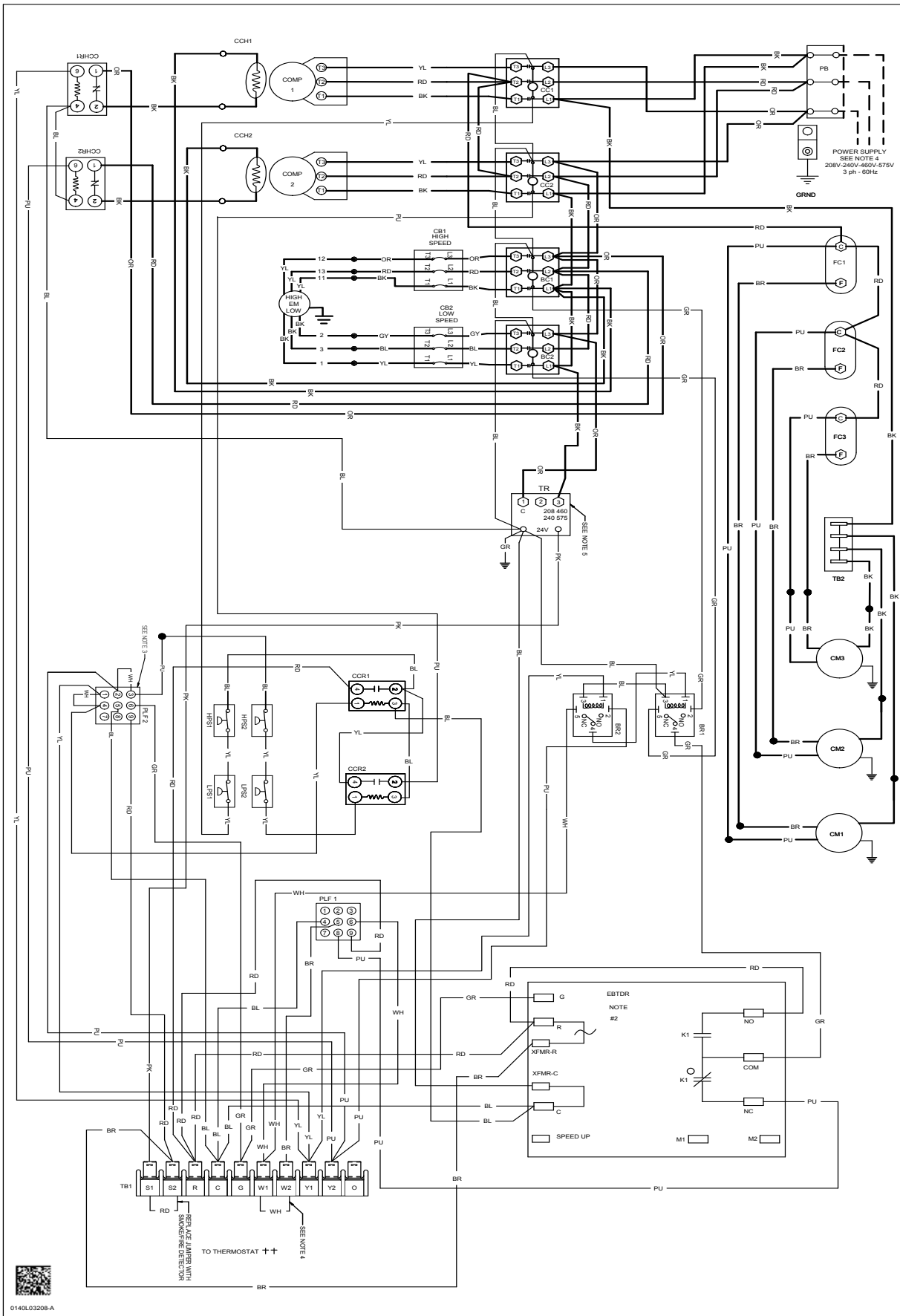

WARNING  **High Voltage:** Disconnect all power before servicing or installing this unit. Multiple power sources may be present. Failure to do so may cause property damage, personal injury, or death.

Wiring is subject to change. Always refer to the wiring diagram on the unit for the most up-to-date wiring.

0140L0320B-A

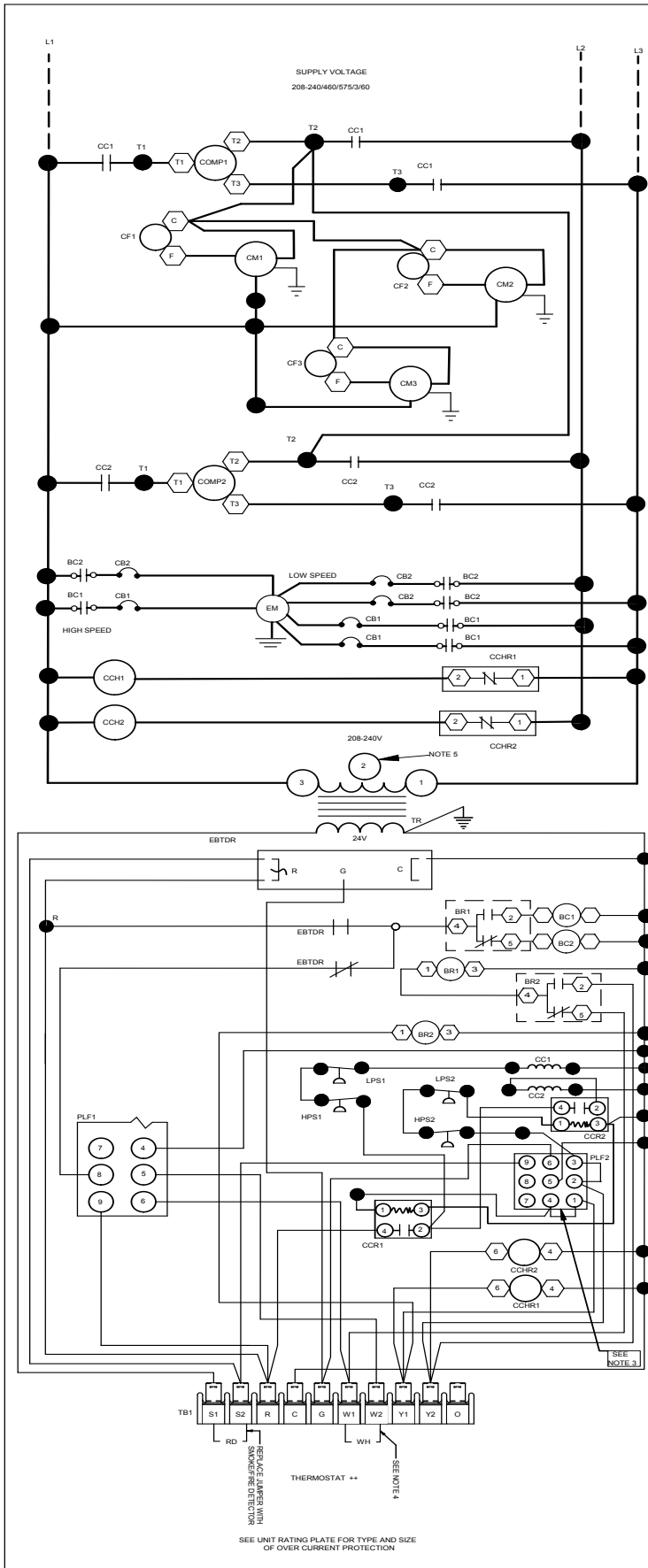

COMPONENT LEGEND

BC	BLOWER CONTACTOR
BR	BLOWER RELAY
CC	COMPRESSOR CONTACTOR
CCH	CRANK CASE HEATER
CCHR	CRANK CASE HEATER RELAY
CCR	COMPRESSOR CONTACTOR RELAY
CM	CONDENSER MOTOR
CMR	CONDENSER MOTOR RELAY
COMP	COMPRESSOR
ECON	ECONOMIZER
EBTD	ELECTRONIC BLOWER TIME DELAY
EMR	EVAPORATOR MOTOR RELAY
R	RELAY
EM	EVAPORATOR MOTOR
FC	FAN CAPACITOR
GND	EQUIPMENT GROUND
HPS	HIGH PRESSURE SWITCH
LPS	LOW PRESSURE SWITCH
PB	POWER DISTRIBUTION BLOCK
PLF	FEMALE PLUG / CONNECTOR
TB1	TERMINAL BLOCK (24V SIGNAL)
TB2	TERMINAL BLOCK (L1)
TR	TRANSFORMER

NOTES:

1. REPLACEMENT WIRE MUST BE SAME SIZE AND TYPE INSULATION AS ORIGINAL (AT LEAST 105°C) USE COPPER CONDUCTOR ONLY.
2. USE COPPER CONDUCTORS ONLY
3. USE N.E.C. CLASS 2 WIRE
4. ECONOMIZER PLUG LOCATED IN THE RETURN AIR COMPARTMENT. REMOVE MALE PLUG, ATTACH FEMALE PLUG TO THE ECONOMIZER ACCESSORY.
5. FOR TWO STAGE OPERATION REMOVE W1 TO W2 WIRE JUMPER.
6. FOR 208V OPERATION MOVE BLACK WIRE FROM TERMINAL ① TO TERMINAL ② ON 240V TRANSFORMER

FACTORY WIRING

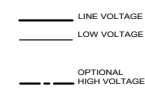

FIELD WIRING

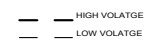

WIRE CODE

BK	BLACK
BL	BLUE
BR	BROWN
GR	GREEN
OR	ORANGE
PK	PINK
PU	PURPLE
RD	RED
WH	WHITE
YL	YELLOW
YL/PK	YELLOW WITH PINK STRIP
BL/PK	BLUE WITH PINK STRIP

TERMOSTAT ++
 FIELD WIRING
 2 STAGE COOLING

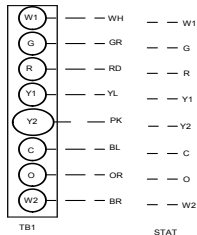

0140L02915-A

High Voltage: Disconnect all power before servicing or installing this unit. Multiple power sources may be present. Failure to do so may cause property damage, personal injury, or death.

WARNING

Wiring is subject to change. Always refer to the wiring diagram on the unit for the most up-to-date wiring.

POWER DIAGRAM
DCC300 *** (3,4,7)

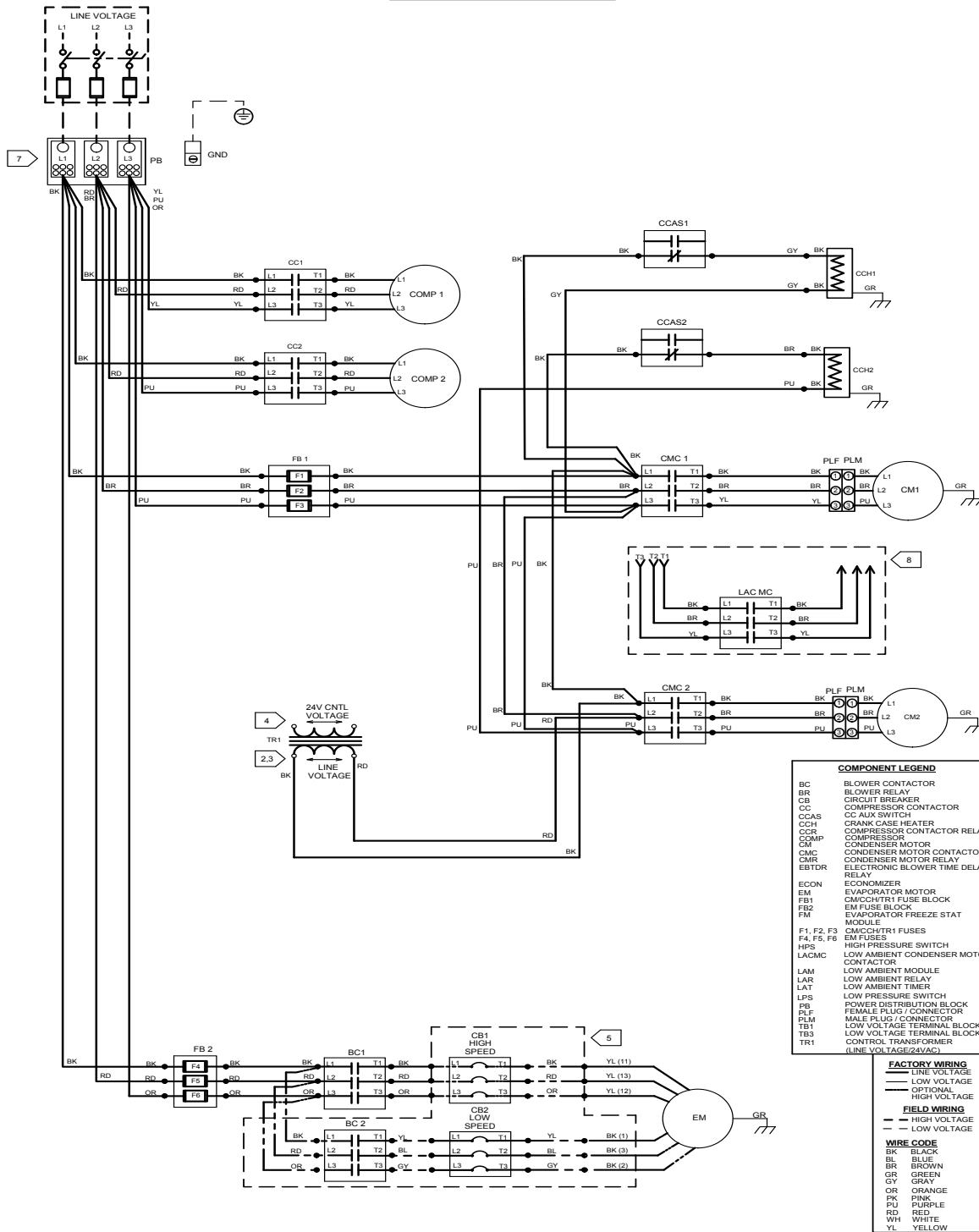

NOTES:

- REPLACEMENT WIRE MUST BE SAME SIZE AND TYPE OF INSULATION AS ORIGINAL (USE COPPER CONDUCTORS ONLY).
- THE CONTROL TRANSFORMER HAS MULTIPLE HIGH VOLTAGE TAPS. ENSURE WIRE CONNECTIONS ARE CORRECT FOR UNIT SUPPLY VOLTAGE RATING.
- 208/230V SUPPLY POWER UNITS ARE FACTORY CONNECTED TO THE CONTROL TRANSFORMER 240V TAP. MOVE WIRE CONNECTION FROM 240V TAP TO 208V TAP WHEN 208V POWER SUPPLY IS USED.
- SEE CONTROL DIAGRAM FOR CONTROL TRANSFORMER LOW VOLTAGE CONNECTIONS.
- OPTIONAL: CB1, CB2, BC2 AND ASSOCIATED WIRING IS PRESENT ONLY WITH 2-SPEED EVAPORATOR MOTOR.
- USE COPPER CONDUCTORS ONLY. UNIT TERMINALS ARE NOT DESIGNED FOR OTHER CONDUCTORS. THE USE OF OTHER TYPE CONDUCTORS MAY CAUSE DAMAGE TO THE UNIT.
- SEE ACCESSORY KIT LITERATURE FOR OPTIONAL ELEC HEAT AND CONVENIENCE OUTLET WIRING DIAGRAMS.
- IF LOW AMBIENT KIT INSTALLED, DISCONNECT CONDENSER MOTOR WIRES (BK, BR, YL) FROM CMC1 (T1, T2, T3) AND CONNECT TO CORRESPONDING BK, BR, YL WIRES ON LOW AMBIENT HARNESS (INSULATED MALE QUICK CONNECT). ALSO CONNECT LOW AMBIENT HARNESS WIRES (BK, BR, YL) (INSULATED FEMALE QUICK CONNECT) TO T1, T2, T3 ON CMC1.



0140L04899-A

High Voltage: Disconnect all power before servicing or installing this unit. Multiple power sources may be present. Failure to do so may cause property damage, personal injury, or death.

WARNING

Wiring is subject to change. Always refer to the wiring diagram on the unit for the most up-to-date wiring.

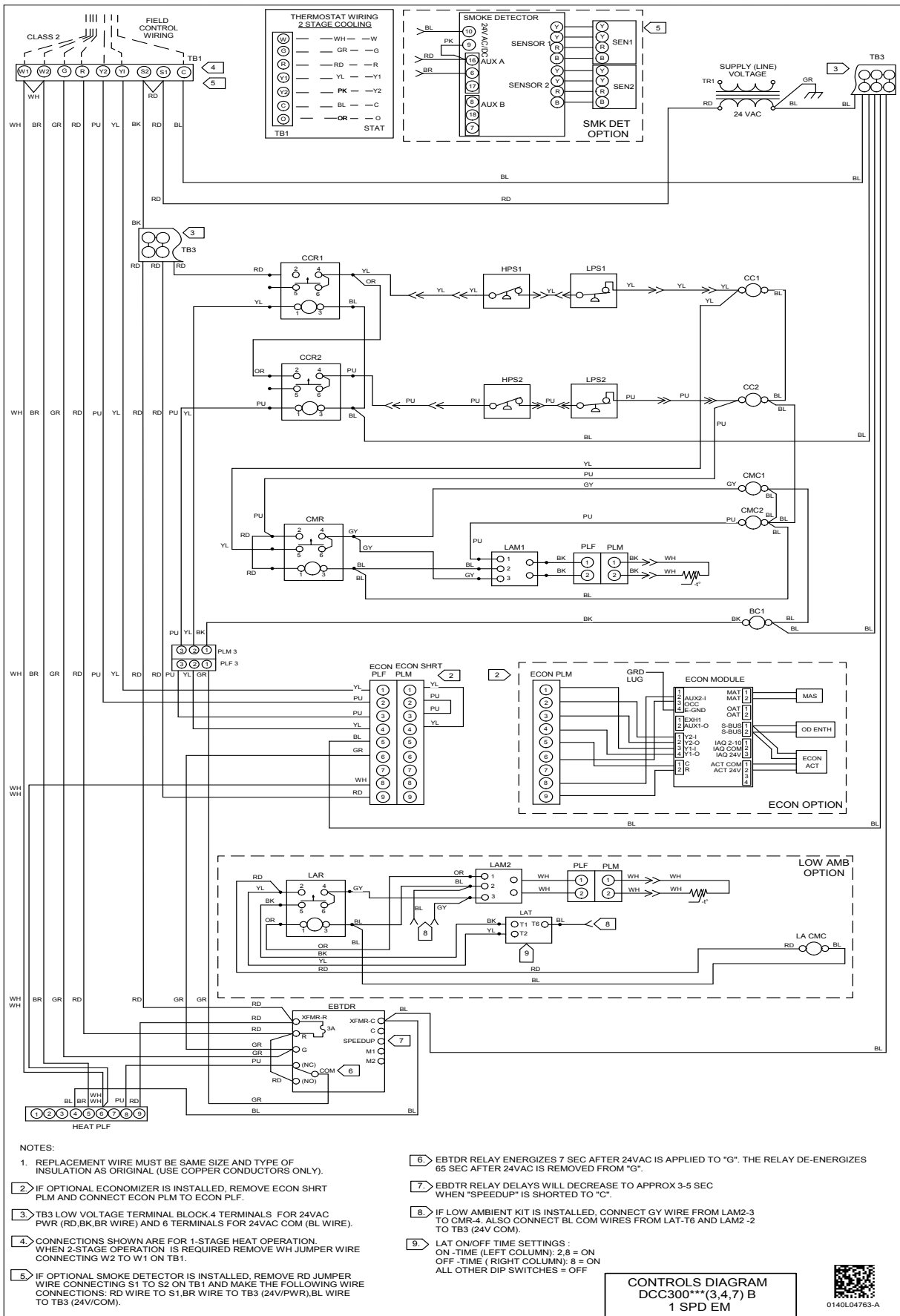

NOTES:

- REPLACEMENT WIRE MUST BE SAME SIZE AND TYPE OF INSULATION AS ORIGINAL (USE COPPER CONDUCTORS ONLY).
- IF OPTIONAL ECONOMIZER IS INSTALLED, REMOVE ECON SHRT PLM AND CONNECT ECON PLM TO ECON PLF.
- TB3 LOW VOLTAGE TERMINAL BLOCK 4 TERMINALS FOR 24VAC PWR (RD,BK,BR WIRE) AND 6 TERMINALS FOR 24VAC COM (BL WIRE).
- CONNECTIONS SHOWN ARE FOR 1-STAGE HEAT OPERATION. WHEN 2-STAGE OPERATION IS REQUIRED REMOVE WH JUMPER WIRE CONNECTING W2 TO W1 ON TB1.
- IF OPTIONAL SMOKE DETECTOR IS INSTALLED, REMOVE RD JUMPER WIRE CONNECTING S1 TO S2 ON TB1 AND MAKE THE FOLLOWING WIRE CONNECTIONS: RD WIRE TO S1, BR WIRE TO TB3 (24V/PWR), BL WIRE TO TB3 (24V/COM).
- EBDTR RELAY ENERGIZES 7 SEC AFTER 24VAC IS APPLIED TO "G". THE RELAY DE-ENERGIZES 65 SEC AFTER 24VAC IS REMOVED FROM "G".
- EBDTR RELAY DELAYS WILL DECREASE TO APPROX 3-5 SEC WHEN "SPEEDUP" IS SHORTED TO "C".
- IF LOW AMBIENT KIT IS INSTALLED, CONNECT GY WIRE FROM LAM2-3 TO CMC4. ALSO CONNECT BL COM WIRES FROM LAT-T6 AND LAM2-2 TO TB3 (24V COM).
- LAT ON/OFF TIME SETTINGS : ON -TIME (LEFT COLUMN): 2,8 = ON OFF -TIME (RIGHT COLUMN): 8 = ON ALL OTHER DIP SWITCHES = OFF

CONTROLS DIAGRAM
DCC300*** (3,4,7) B
1 SPD EM



High Voltage: Disconnect all power before servicing or installing this unit. Multiple power sources may be present. Failure to do so may cause property damage, personal injury, or death.

WARNING

Wiring is subject to change. Always refer to the wiring diagram on the unit for the most up-to-date wiring.

WIRING DIAGRAM — DCC 25 TONS (230V/460V/575V, TWO-SPEED BELT DRIVE - CONTROLS DIAGRAM)

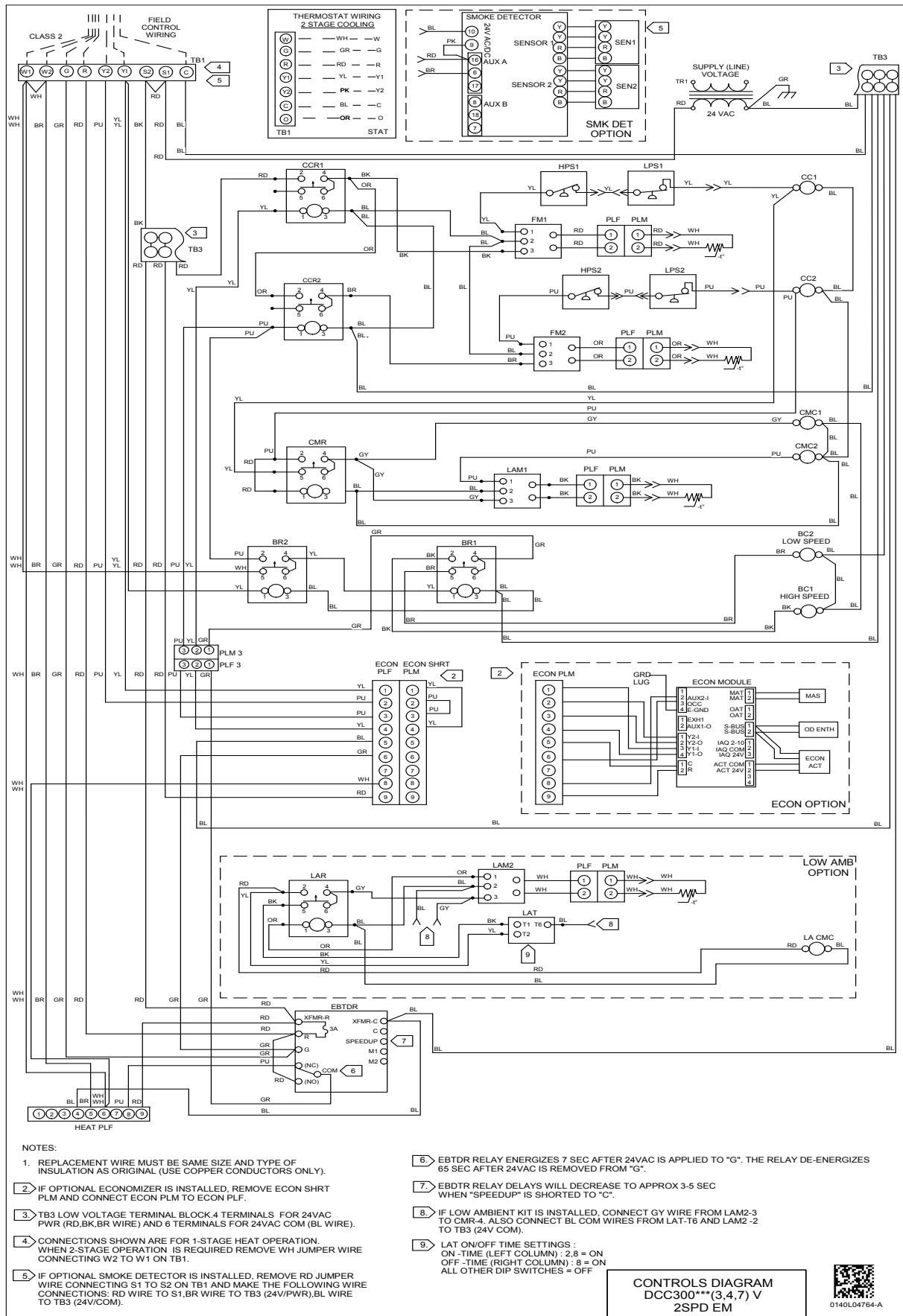

NOTES:

1. REPLACEMENT WIRE MUST BE SAME SIZE AND TYPE OF INSULATION AS ORIGINAL (USE COPPER CONDUCTORS ONLY).
2. IF OPTIONAL ECONOMIZER IS INSTALLED, REMOVE ECON SHRT PLM AND CONNECT ECON PLM TO ECON PLM.
3. TB3 LOW VOLTAGE TERMINAL BLOCK 4 TERMINALS FOR 24VAC PWR (RD,BK,BR WIRE) AND 6 TERMINALS FOR 24VAC COM (BL WIRE).
4. CONNECTIONS SHOWN ARE FOR 1-STAGE HEAT OPERATION. WHEN 2-STAGE OPERATION IS REQUIRED REMOVE WH JUMPER WIRE CONNECTING S1 TO S2 ON TB1 AND MAKE THE FOLLOWING WIRE CONNECTIONS: RD WIRE TO S1, BR WIRE TO TB3 (24V/PWR), BL WIRE TO TB3 (24V/COM).
5. IF OPTIONAL SMOKE DETECTOR IS INSTALLED, REMOVE RD JUMPER WIRE CONNECTING S1 TO S2 ON TB1 AND MAKE THE FOLLOWING WIRE CONNECTIONS: RD WIRE TO S1, BR WIRE TO TB3 (24V/PWR), BL WIRE TO TB3 (24V/COM).
6. EBTDR RELAY ENERGIZES 7 SEC AFTER 24VAC IS APPLIED TO "G". THE RELAY DE-ENERGIZES 65 SEC AFTER 24VAC IS REMOVED FROM "G".
7. EBTDR RELAY DELAYS WILL DECREASE TO APPROX 3-5 SEC WHEN "SPEEDUP" IS SHORTED TO "C".
8. IF LOW AMBIENT KIT IS INSTALLED, CONNECT GY WIRE FROM LAM2-3 TO CMR-4. ALSO CONNECT BL COM WIRES FROM LAT-T6 AND LAM2-2 TO TB3 (24V COM).
9. LAT ON/OFF TIME SETTINGS : ON -TIME (LEFT COLUMN) : 2,8 = ON OFF -TIME (RIGHT COLUMN) : 8 = ON ALL OTHER DIP SWITCHES = OFF

CONTROLS DIAGRAM
DCC300***(3,4,7) V
2SPD EM



0140L04764-A

High Voltage: Disconnect all power before servicing or installing this unit. Multiple power sources may be present. Failure to do so may cause property damage, personal injury, or death.

WARNING

Wiring is subject to change. Always refer to the wiring diagram on the unit for the most up-to-date wiring.

FILED-INSTALLED ITEM #	DESCRIPTION	FITS MODEL SIZES	FIELD- INSTALLED	FACTORY- INSTALLED
14CURB180300	14" Roof Curb	15-25 tons	√	
D25FD180300	25% Manual Fresh Air Damper	15-25 tons	√	
D25MFD180300	25% Motorized Fresh Air Damper	15-25 tons	√	
DDNBB180240	Burglar Bar Sleeves with Supply and Return	15-25 tons	√	
CDK180	Concentric Duct Kit	15 tons	√	
CDK240	Concentric Duct Kit	20 tons	√	
CDK300	Concentric Duct Kit	25 tons	√	
	Convenience Outlet: Powered	All Models		√
	Convenience Outlet: Non Powered	All Models		√
	Disconnect Switch (non-fused)	All Models		√
DDNECNJ180300B	Downflow Economizer	15-25 tons	√	
	Downflow Economizer	15-25 tons		√
	Electric Heat Kits (75kW not available as factory-installed kit)	All Models	√	√
HSKT180 ¹	High-Static Kit (230/460v)	15 tons	√	
HSKT180-7 ¹	High-Static Kit (575v)	15 tons	√	
HSKT240 ¹	High-Static Kit (230/460v)	20 tons	√	
HSKT240-7 ¹	High-Static Kit (575v)	20 tons	√	
HSKT300C	High-Static Kit (all voltages)	25 tons	√	
HZCURB180240ED	Horizontal Discharge Curb — End Discharge	15-25 tons	√	
HZCURB180240SDN	Horizontal Discharge Curb — Side Discharge; duct openings on non-service side	15-25 tons	√	
HZCURB180240SDS	Horizontal Discharge Curb — Side Discharge; duct openings on service side	15-25 tons	√	
GHRC-1	Hurricane Restraint Clips	All Models	√	
LAKT03	Low-Ambient Kit	15-20 tons	√	√
LAKT05	Low-Ambient Kit (208/230V & 460V)	25 tons	√	√
DPE1803002	Power Exhaust (208/230v)	15-25 tons	√	
DPE1803004	Power Exhaust (460v)	15-25 tons	√	
DPE1803007	Power Exhaust (575v)	15-25 tons	√	
	Smoke Detector	All Models		√
FSKT02A	Freeze Stat Kit	25 tons	√ ²	

¹ HSKT High-static kits are for use with standard single-speed belt-drive units only.

² FSK02A is standard on 2 speed, V, models, and field installed for single speed, B, models.

