

CircuitSolver® Union Assembly with Strainer (CSUAS)

[Thermostatic balancing valve with integrated union body, ball valves, and strainer]

SUBMITTAL

JOB:	ORDER NO:	DATE:
	SUBMITTED BY:	DATE:
UNIT TAG:	APPROVED BY:	DATE:
CITY:	ENGINEER:	BUILDING TYPE:
STATE:	CONTRACTOR:	CONSTRUCTION TYPE:
COMPLETION DATE:		

DESCRIPTION

The CircuitSolver® Union Assembly with Strainer's primary component is the CircuitSolver® which is a self-acting thermostatic recirculation valve that automatically and continuously maintains the end of each domestic hot water supply line at the specified water temperature. Since the CircuitSolver® responds to water temperature and controls flow to the return, it eliminates the need to manually balance the system. The featured strainer (20 mesh) must be maintained in order to avoid flow obstruction.

DIMENSIONS

Item No.	Part Number	Description	Qty.	Item No.	Part Number	Description	Qty.	Item No.	Part Number	Description	Qty.
1	258-20X100-XXX	½" CIRCUITSOLVER® THERMOSTATIC BALANCING VALVE WITH INTEGRATED UNION	1	1	258-30X100-XXX	¾" CIRCUITSOLVER® THERMOSTATIC BALANCING VALVE WITH INTEGRATED UNION	1	1	258-40X100-XXX	1" CIRCUITSOLVER® THERMOSTATIC BALANCING VALVE WITH INTEGRATED UNION	1
2	92-162	½" X CL NIPPLE BRASS LF	1	2	92-026	¾" X CL NIPPLE BRASS LF	1	2	92-044	1" X CL NIPPLE BRASS LF	1
3	92-160	BALL VALVE, ½" MxF, LF	2	3	92-158	BALL VALVE, ¾" MxF, LF	2	3	92-170	BALL VALVE, 1" MxF, LF	2
4	92-200	Y-STRAINER, ½" BRASS	1	4	92-201	Y-STRAINER, ¾" BRASS	1	4	92-202	Y-STRAINER, 1" BRASS	1

*ALL COMPONENTS ARE LEAD-FREE

*ALL COMPONENTS ARE LEAD-FREE

*ALL COMPONENTS ARE LEAD-FREE

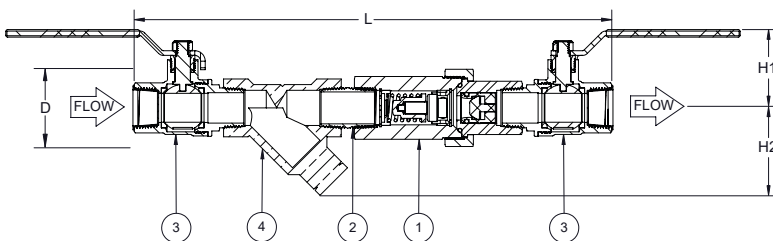

Model No.	NPT	Diameter (D)		Length (L)		Height 1 (H1)		Height 2 (H2)		Weight		C _v			Max. Pressure		Max. Temp.	
		IN	MM	IN	MM	IN	MM	IN	MM	LBS.	KG	OPEN	CLOSED	DESIGN	PSIG	BAR	°F	°C
CSUAS- ½ -XXX	1/2"	1.8	46	10.8	275	1.8	46	2.5	64	2.9	1.3	1.3	0.2	0.60	200	14	250	121
CSUAS- ½ -XXX-CV1																		
CSUAS- ¾ -XXX	3/4"	2.0	51	12.8	326	2.0	51	3.3	84	4.7	2.1	1.8	0.2	0.85				
CSUAS- ¾ -XXX-CV1																		
CSUAS-1-XXX	1"	2.5	64	14.4	366	2.3	59	3.8	97	7.0	3.2	3.3	0.2	1.57				
CSUAS-1-XXX-CV1																		

Model Number Selection

XXX refers to the desired closing temperature. When the water temperature drops below this point the CircuitSolver® will begin to open, allowing water to easily enter the return line. For example, if you want 120°F desired return temperature and the CSUAS is to be installed on a 3/4" line, the model number would be CSUAS-3/4-120. To add optional check valve insert -CV1 directly after the temperature designation in the model number. Ex. CSUAS-3/4-120-CV1

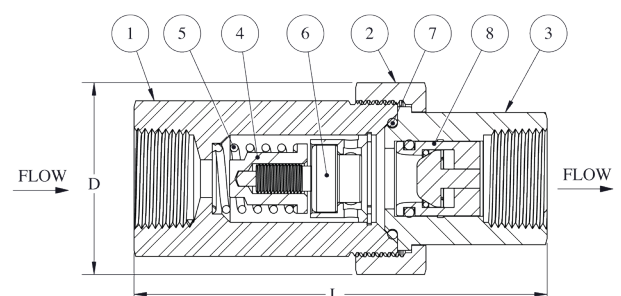
MATERIALS		
		
ITEM	DESCRIPTION	MATERIAL
1	Valve Body w/ Union Threads	300 series stainless steel
2	Union Nut	300 series stainless steel
3	Female Threaded Insert	300 series stainless steel
4	Plug	300 series stainless steel
5	Operating Spring	300 series stainless steel
6	Thermal Actuator	300 series stainless steel
7	O-ring	Buna-N
8	Check Valve (optional)	GLASS FILLED NORLYL

FLOW RATE CALCULATION USING "Cv" FACTOR		
$GPM = C_v \sqrt{\Delta P}$	$C_v = \sqrt{\frac{GPM}{\Delta P}}$	$\Delta P = \left[\frac{GPM}{C_v} \right]^2$

TYPICAL SPECIFICATION

- I. Furnish and install CIRCUITSOLVER® UNION ASSEMBLY with STRAINER as indicated on the plans. CIRCUITSOLVER® UNION ASSEMBLY with STRAINER shall be self-contained and fully automatic without additional piping or control mechanisms. Thermostatic valve shall be a CIRCUITSOLVER® as manufactured by ThermOmegaTech®, Inc., or equivalent.
 - A. CIRCUITSOLVER® shall regulate the flow of recirculated domestic hot water based on water temperature entering the CIRCUITSOLVER® UNION ASSEMBLY with STRAINER regardless of system operating pressure. As the water temperature increases the valve proportionally closes dynamically adjusting flow to meet the specified temperature.
 1. CIRCUITSOLVER® never fully closes, even at the desired set point. There is always sufficient bypass flow back to the recirculating pump to prevent overheating or "dead heading" of the pump.
 2. CIRCUITSOLVER® is set at the factory for the desired return temperature. No field adjustments needed. Several temperature set points are available.
 3. CIRCUITSOLVER® UNION ASSEMBLY with STRAINER shall be available in ½", ¾", & 1" with FNPT at both ends.
- II. All components in the CIRCUITSOLVER® UNION ASSEMBLY with STRAINER are made with lead-free materials. The major components that make up the CIRCUITSOLVER® are constructed of type 300 series SS.
 - A. CIRCUITSOLVER® UNION ASSEMBLY with STRAINER shall be rated to 200 PSIG maximum working pressure.
 1. CIRCUITSOLVER® UNION ASSEMBLY with STRAINER shall be standard tapered female pipe thread, NPT.
 - B. CIRCUITSOLVER® UNION ASSEMBLY with STRAINER shall be rated to 250°F (121.1°C) maximum working temperature.
 - C. CIRCUITSOLVER® UNION ASSEMBLY with STRAINER shall have all lead-free components.
 - D. Thermal actuator shall be spring-loaded and self-cleaning, delivering closing thrust sufficient to keep orifice opening free of scale deposits.
- III. Installation of CIRCUITSOLVER® UNION ASSEMBLY with STRAINER shall be made by qualified tradesmen. Install CIRCUITSOLVER® UNION ASSEMBLY with STRAINER in each domestic hot water return piping branch beyond last hot water device in that branch.
 - A. Strainer is integrated in the valve assembly.
 - B. Provide suitable access panel as required in non-accessible ceilings and walls.
 - C. Pay close attention to flow arrow, especially with valves that have an integrated check valve.

OPTIONAL CHECK VALVE	
Features and Benefits	
-100% factory tested drip tight operation	
-Snap fit design, no retainer needed	
-Extra-low head loss and low cracking pressure	
-External O-ring in groove	
Certifications	
-ANSI/ NSF 61	
ITEM	MATERIAL
Cap	Glass filled Noryl
Guide	Glass filled Noryl
Plunger	Glass filled Noryl
Lip Spring	EPDM rubber
Spring	Stainless Steel AISI 301
O-ring	EPDM rubber

OPTIONAL CHECK VALVE TECHNICAL DATA	
Medium: Clear water only	
Approximate Cracking Pressure: 0.29 PSI	
Continuous	Short-term (5 minutes max.)
