

CANTEX INC.
301 Commerce Ste 2700
Fort Worth, Texas 76102
817-215-7000
Fax: 817-215-7001

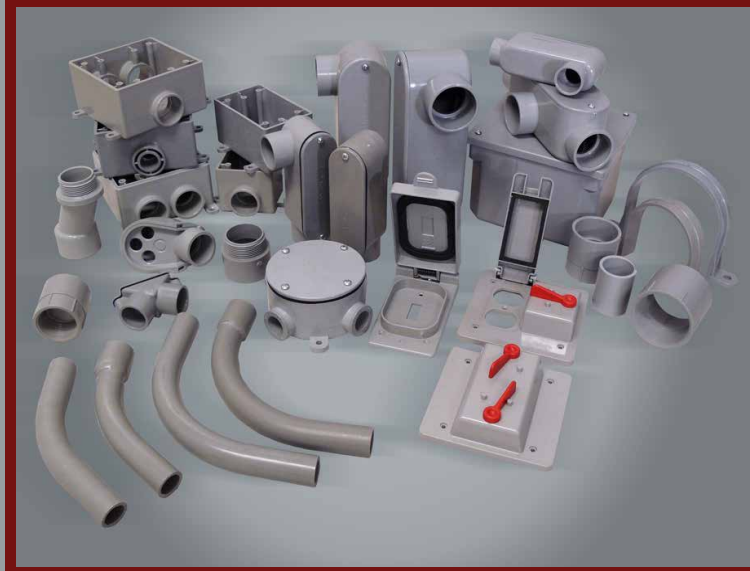

- Conduit**
- Fittings & Accessories**
- Directional Drilling Conduit**
- Utility Duct**
- Telephone Duct**
- Residential Boxes**

YOUR FULL LINE SOURCE FOR PVC ELECTRICAL PRODUCT

Our corporate commitment to our distributors is backed by continuing investments in plant facilities, production capacity, inventory and distribution systems. We have the products you need when you need them.

Table of Contents

About CANTEX®	4-5
Schedule 40 / Schedule 80 Fittings & Accessories	9-17
<i>Couplings, Female Adapters, Terminal Adapters, Pipe Straps, Expansion Couplings, Reducers, Box Adapters, End Caps, Molded Sch. 40 End Bells, Plugs, Pull Elbows, Sealing Washers, Strain Relief Connectors, Insulating Bushings, Sch. 40 Longline Couplings, Sch. 40 Swedged Couplings, Sch. 40 Split Sleeve Coupling, Fabricated End Bells</i>	
Sch. 40 Standard Radius Elbows, Plain End & Bell End	18-21
Sch. 40 Special Radius Elbows, Plain End & Bell End	22-34
Sch. 80 Standard Radius Elbows, Plain End & Bell End	35-38
Sch. 80 Special Radius Elbows, Plain End & Bell End	39-43
Conduit Bodies	47-49
Junction Boxes, Floor Boxes & Accessories	50-51
Exposed Electrical Boxes & Weatherproof Covers	55-67
Fittings for Type EB and DB Utility Duct	71-76
<i>Terminal Adapters, Female Adapters, Longline Couplings, 5° Couplings Fabricated, TC6 End Bells, Reducers, TC6 End Bells, Stoppers, Caps, Poly Plugs</i>	
Special Radius Elbows for Type EB and DB Utility Duct Bell End	77-84
Type EB/DB Accessories	87-93
<i>Service Entrance Caps, Meter Offsets, Offsets, Expansion Joints, Service Risers, Spacers</i>	
Schedule 40 Conduit	97
Schedule 80 Conduit	98
Forte-Duct®	99
Split Duct & Accessories	100
NEMA DBHM Utility Duct, NEMA EBHM Utility Duct, DB-100	101-102
P&C Flexible Utility Duct	103
EZ-Flex® Nonmetallic Tubing, ENT Accessories and ENT Boxes	107-109
Enviro-Flex Liquid Tight Conduit & Fittings	113-114
Direction Drilling Schedule 40 Conduit	116-117
Telephone Conduit and Fittings	119-138
Solvent Cement & Primer	141
EZ Box® Residential Boxes	145-178
EZ Box® Cross Reference	179-182
Conduit Installation Guidelines	183-189
Conduit Engineering and Design Data	188-193
Conduit & Utility Duct Packaging Data	194-195
Limited Warranty	196
Authorized Distributor Policy	197-198

PVC PRODUCTS

CANTEX is a leading producer of PVC products, with eight manufacturing facilities located strategically from east to west across the country. These facilities feature some of the most modern production equipment and advanced process technology found anywhere in the industry. Production facilities include extrusion, injection molding, and fabrication processes to produce the broad lines of PVC Products which serve the power, utility, building construction, and communications markets.

CANTEX PVC Products had its beginning over 60 years ago, as a division of a national corporation in the utility and building construction industry. The Plastics Division grew steadily in size and importance. Its product lines expanded into several major categories:

- Electrical distributors and contractors were provided with a broad line of PVC conduit and fittings.
- Power and utility companies were supplied with underground PVC duct and fittings.
- For the communications industry, PVC conduit and fittings were made available to telephone and cable companies for underground cable installations.
- Municipal public works needs were met with PVC pipe for distribution and collection.
- The commercial market need was fulfilled with PVC plumbing pipe.

ELECTRICAL PRODUCT LINE

CANTEX offers a complete line of extruded and injection molded electrical conduit, duct, fittings, accessories, switch and outlet boxes. Products include a full range of sizes in:

- Schedule 40 & 80 Conduit
- Electrical Fittings & Accessories – Molded & Fabricated
- Schedule 40 Conduit for Directional Drilling Applications
- Utility Duct – NEMA TC-6 & 8 - EB35, DB60, DB100, DB120
- Schedule 40 Forte-Duct® Cellular Core PVC Conduit
- Duct Fittings & Accessories
- Elbows, Bends & Sweeps – Standard & Special Radius
- EZ-FLEX® Electrical Nonmetallic Tubing & Fittings
- ENVIRO-FLEX® Liquid Tight Conduit & Fittings
- Telephone Conduit – Types B-C-D
- EZ BOX® Wall and Ceiling Switch and Outlet Boxes
- Cements

SERVICE

CANTEX stands for a commitment to service – service that puts the customer first. Our efficient transportation system means on-time deliveries anywhere in the U.S. The CANTEX customer service team is staffed by professionals who provide immediate response and effective communications about orders and shipments.

At the NEW CANTEX, WE WORK FOR THE CUSTOMER.

INDUSTRY ORGANIZATIONS

CANTEX actively supports those organizations which set standards and promote professional practices in the electrical industry. These include NEMRA, NAED, IAEI, IEEE, along with other associations in the construction industry.

QUALITY ASSURANCE

CANTEX has a comprehensive quality control program to ensure compliance with industry standards established by Underwriters Laboratories, National Electrical Code, the American Society for Testing and Materials and Canadian Standards Association.

From virgin raw materials blended into compounds through extrusion or injection molding to final inspection and testing of the finished product, the manufacturing process is monitored to make sure quality standards are met or exceeded.

Each plant is graded and held accountable for the quality control performance of its total output.

To further strengthen the company's goal for quality products, a centralized quality control review procedure ensures that every plant is producing at a consistent level of quality for all similar products. You know you're getting the very best every time you buy from **CANTEX**.

PVC ELECTRICAL STANDARDS BY PRODUCT

Schedule 40 Conduit

UL 651, NEMA TC-2 and NEC-Article 352
CSA C22.2 No. 211.2

Schedule 80 Conduit

UL 651, NEMA TC-2 and NEC-Article 352

PVC Electrical Fittings

Fittings for electrical applications conform to one or more of the following specifications:
NEMA TC-3 and UL 514B, UL651,
NEMA TC-6&8, ASTM F-512, UL 50,
CSA 22.2 No. 211.2 85-M89

Utility Duct - Extra Strength

NEMA TC 6&8 and ASTM F-512

Utility Duct Fittings

NEMA TC-9

EZ-FLEX ENT (Electrical Nonmetallic Tubing) & Fittings

NEMA TC-13 and NEC Article 362 UL 1653A

ENVIRO-FLEX Liquidtight Conduit

UL1660, NEC 356
CSA 22.2 No. 227.2.1

ENVIRO-FLEX Liquidtight Fittings

UL 514B and NEMA FB-1

Uniform Product Code

UPC-A

Item bar code identifies a single product unit.



UPC-ITF

Shipping container bar code identifies each standard carton of products.



Schedule 40 / Schedule 80 Fittings & Accessories

Standard UL Coupling

Part Number	Trade Size	Carton Qty.	"W"	"L"	"ID"	"D"
6141623	1/2	200	1.063	1.500	.875	.625
6141624	3/4	125	1.313	1.563	1.063	.625
6141625	1	70	1.625	2.000	1.313	1.000
6141626	1-1/4	40	2.000	2.125	1.688	1.000
6141627	1-1/2	30	2.250	2.375	1.938	1.063
6141628	2	40	2.688	2.438	2.375	1.250
6141629	2-1/2	20	3.250	3.500	2.875	1.750
6141630	3	40	4.000	3.875	3.500	1.188
6141631	3-1/2	30	4.1250	4.000	4.000	1.938
6141632	4	20	5.000	4.188	4.500	2.000
6141633	5	10	6.125	5.375	5.625	2.500
6141634	6	8	7.250	6.375	6.625	3.000
* 6141635D	8	1	--	--	--	--

* Not UL Listed

Dimensions are nominal



A connector used to join lengths of conduit pipe. The fitting consists of two solvent weld female ends with a center stop. Both pieces of pipe should seat at the stop for proper positioning.

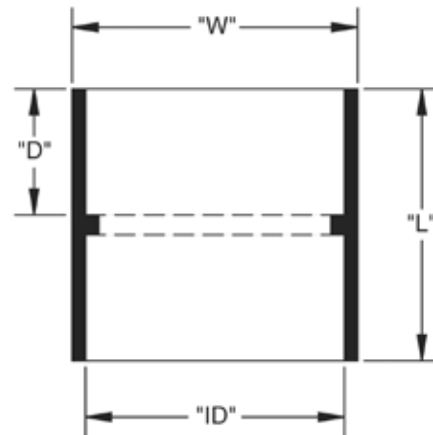

Female Adapter

Part Number	Trade Size	Carton Qty.	"W"	"L"	"D"
5140043	1/2	200	1.000	1.438	.688
5140044	3/4	125	1.250	1.625	.688
5140045	1	70	1.563	1.875	.875
5140046	1-1/4	40	2.000	1.938	.938
5140047	1-1/2	30	2.250	2.125	.938
5140048	2	40	2.688	2.125	.938
5140049	2-1/2	20	3.313	3.000	1.313
5140050	3	40	4.000	3.063	1.250
5140051	3-1/2	30	4.500	3.000	1.188
5140052	4	20	5.000	3.250	1.375
5140053	5	10	6.125	3.688	1.313
5140054	6	8	7.250	4.375	1.625
* 5140055D	8	2	9.313	7.000	2.250

* Not UL Listed

Dimensions are nominal



A connector often used to transition threaded metal conduit to PVC conduit. It can also be used to join PVC to PVC. The fittings consist of two female ends. One end is threaded and the other is solvent weld. Both ends will fit the same diameter conduit.

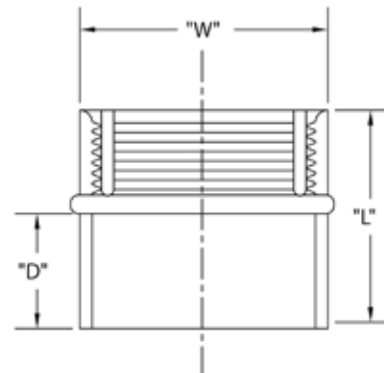

Schedule 40 / Schedule 80 Fittings & Accessories

Terminal (Male) Adapter

A connector used to transition from plain end PVC conduit to a threaded metal or plastic female bell. Can also be used to connect PVC conduit to a box or other threaded body with use of a lock nut. The fitting consists of one solvent weld female end and one threaded male end. Both ends will fit the same diameter conduit.

1/2" thru 1-1/2" Terminal (Male) Adapter



1/2" thru 1-1/2"

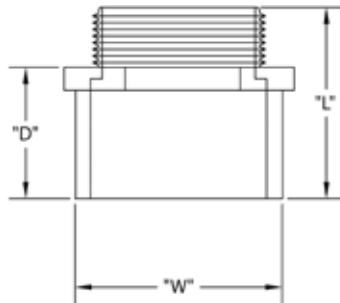

Part Number	Trade Size	Carton Qty.	"W"	"L"	"D"
5140103	1/2	200	1.063	1.688	1.125
5140104	3/4	125	1.250	1.750	1.188
5140105	1	70	1.625	2.188	1.500
5140106	1-1/4	40	2.000	2.125	1.313
5140107	1-1/2	30	2.000	2.063	1.313

Dimensions are nominal

2" thru 6" Terminal (Male) Adapter



2" and Larger

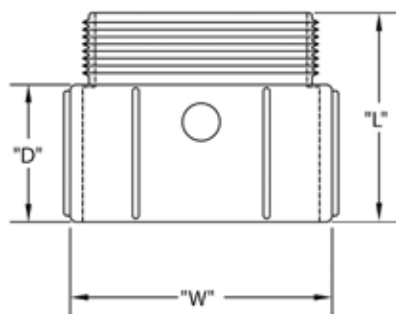

Part Number	Trade Size	Carton Qty.	"W"	"L"	"D"
5140108	2	40	2.688	2.188	1.375
5140109	2-1/2	20	3.313	2.875	2.000
5140110	3	40	3.938	3.000	2.188
5140111	3-1/2	30	4.500	3.188	2.563
5140112	4	20	5.000	3.438	2.563
5140113	5	10	6.250	4.750	3.000
5140114	6	8	7.313	4.938	2.688
5140115D	8	2	--	--	--

Dimensions are nominal

Conduit Clamps (Pipe Straps)



A u-shaped conduit support device used to anchor conduit to interior or exterior surfaces. Two holes in the feet of the clamp allow mounting with screws or nails.

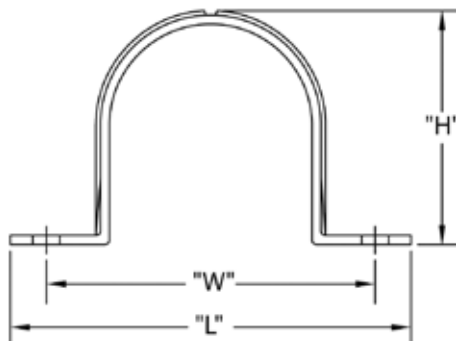

Part Number	Trade Size	Carton Qty.	"W"	"L"	"H"
5133736	1/2	300	1.688	2.188	1.000
5133737	3/4	200	2.000	2.500	1.250
5133738	1	200	2.250	2.813	1.500
5133733	1-1/4	200	2.500	3.125	1.813
5133734	1-1/2	200	2.688	3.375	2.125
5133735	2	200	3.313	4.000	2.563
5133739	2-1/2	100	4.563	5.500	3.000
5133740	3	100	5.125	6.000	3.563
5133353	4	100	6.000	7.000	4.625

Dimensions are nominal

Schedule 40 / Schedule 80 Fittings & Accessories

Expansion Couplings - One Piece

Part Number	Trade Size	Carton Qty.	"W"	"L"	Travel Length
5144026	1/2	50	1.000	5.813	4.000
5144015	3/4	50	1.313	6.375	4.000
5144016	1	50	1.563	6.750	5.000
5144017	1-1/4	25	2.000	7.250	5.000
5144018	1-1/2	25	2.188	7.438	5.000
5144019	2	25	2.688	8.438	6.000
5144020	2-1/2	5	3.188	8.875	6.000
5144021	3	10	4.000	9.250	6.000
5144023	4	5	5.000	10.000	7.000

Dimensions are nominal

1/2" through 3/4" Maximum Expansion - 4"	2" through 3" Maximum Expansion - 6"
1" through 1-1/2" Maximum Expansion - 5"	3-1/2" through 4" Maximum Expansion - 7"

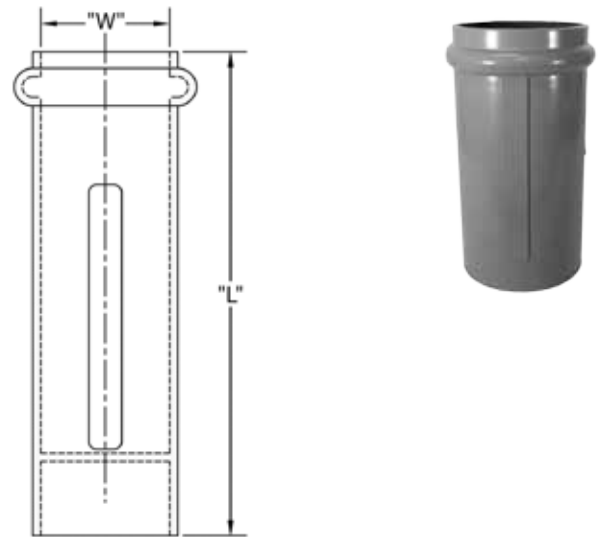

Expansion Couplings - Two Piece

Part Number	Trade Size	Carton Qty.	"A"	"B"	"C"	"D"
5144031	1/2	25	.875	7.000	.688	8.125
5144032	3/4	10	1.063	7.000	.875	8.125
5144033	1	10	1.313	7.063	1.000	8.375
5144034	1-1/4	5	1.688	7.625	1.000	9.000
5144035	1-1/2	5	1.938	7.563	1.125	9.000
5144036	2	25	2.375	7.688	1.188	9.250
5144037	*2-1/2	12	2.875	12.000	1.875	14.938
5144038	3	12	3.500	12.000	1.875	14.938
5144039	*3-1/2	6	4.000	12.375	2.000	14.875
5144040	4	6	4.500	12.313	2.125	14.875
**5144041	*5	1	5.563	19.250	2.938	24.000
**5144042	*6	1	6.625	20.813	3.000	26.375

* Not UL Listed ** Fabricated

Dimensions are nominal

1/2" through 2" Maximum Expansion - 4"	2-1/2" through 6" Maximum Expansion - 8"
---	---

A two piece coupling with solvent weld bells in each end. The spigot part of the joint slides through an internal o-ring to compensate for temperature changes.

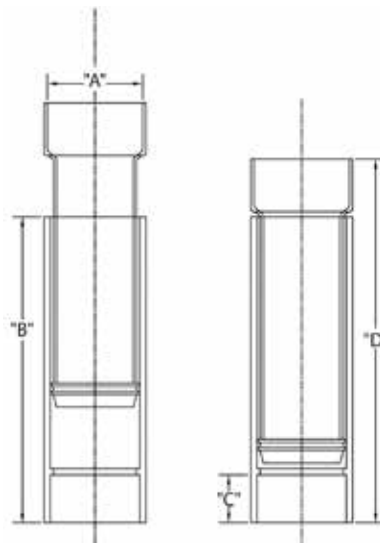

Schedule 40 / Schedule 80 Fittings & Accessories

Reducers

Part Number	Trade Size	Carton Qty.	"H"	"C"	"T"	"OD"	"IDE"	"IDB"
5142220	3/4 x 1/2	100	1.000	.120	.630	1.050	.852	.836
5142230	1 x 1/2	100	--	--	--	--	--	--
5142221	1 x 3/4	100	1.180	.120	.834	1.315	1.064	1.046
5142222	1-1/4 x 1	50	1.420	.140	1.059	1.660	1.330	1.310
5142251	1-1/2 x 1	25	--	--	--	--	--	--
5142223*	1-1/2 x 1-1/4	50	1.370	.180	1.392	1.900	1.677	1.655
5142224*	2 x 1-1/2	25	1.600	.250	1.622	2.375	1.918	1.894
5142225*	2-1/2 x 2	25	1.900	.250	2.076	2.875	2.391	2.370
5140867	3 x 2	25	2.24	.250	2.085	3.500	2.393	2.362
5142226*	3 x 2-1/2	25	2.250	.250	2.484	3.500	2.890	2.868
5142227*	4 x 3	20	2.600	.370	3.083	4.500	3.515	3.492
5142229*	4 x 3-1/2	20	2.600	.400	3.598	4.500	4.015	3.992

A bushing designed to fit into a bell end or female fitting to reduce from one diameter to the next smaller conduit diameter. Male and female elements of the bushing are solvent weld.

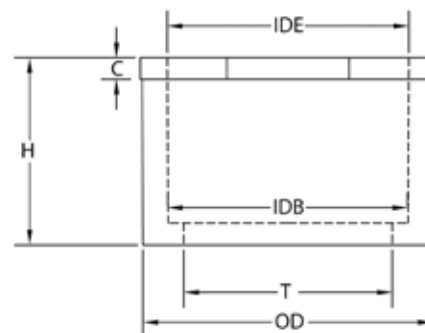

* CSA Certified

Dimensions are nominal

Box Adapters

Part Number	Trade Size	Carton Qty.	"D" (Min)	"S" (Min)	"OD"	"ID" (Min)	"H"	"T" (Min)
5133715	1/2	100	.700	.140	1.200	.578	.840	.095
5133716	3/4	100	.725	.140	1.400	.780	1.050	.095
5133717	1	100	.950	.140	1.700	1.004	1.315	.100
5133718	1-1/4	50	.990	.250	2.000	1.335	1.660	.120
5133719	1-1/2	50	1.100	.200	2.000	1.564	1.900	.120
5133720	2	25	1.175	.200	2.750	2.021	2.375	.130
5133721*	2-1/2	10	1.650	.300	3.350	2.424	2.875	.165
5133722	3	10	1.800	.325	4.200	3.008	3.500	.216
5133723*	3-1/2	10	1.870	.325	4.500	3.486	4.000	.226
5133724*	4	10	2.020	.250	4.910	3.961	4.500	.237

Meets NEMA TC3 Requirements
Made of Rigid PVC

Adapter used with the hub inside a box or enclosure. The cylinder protrudes through a hole in the box wall and is solvent welded to a female fitting outside the box or enclosure.

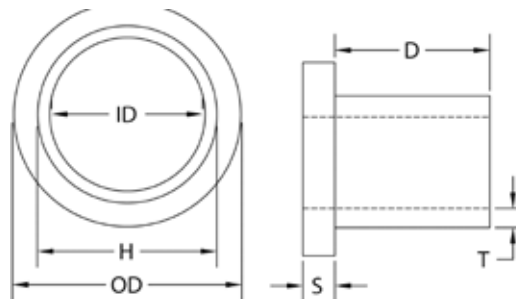

* CSA Certified

Dimensions are nominal

Schedule 40 / Schedule 80 Fittings & Accessories

End Cap

Meets NEMA TC3 Requirements
Made of Rigid PVC

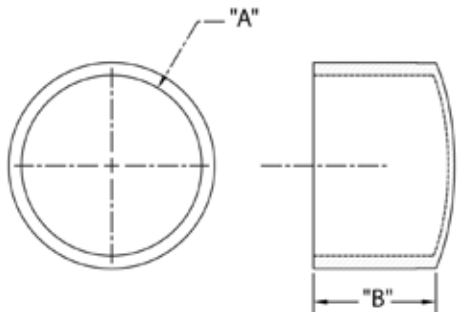

1/2" through 4"
have dome top



5" and 6" have flat top



Part Number	Trade Size	Carton Qty.	"A"	"B"
5140031	1/2	100	.875	.875
5140032	3/4	100	1.063	1.063
5140033	1	50	1.375	1.250
5140034	1-1/4	25	1.688	1.313
5140035	1-1/2	25	1.938	1.563
5140037	2	50	2.375	1.625
5140038	2-1/2	25	2.875	2.000
5140039	3	25	3.563	2.375
5140036	3-1/2	25	4.000	2.313
5140040	4	25	4.500	2.375
5140041	5	25	5.563	2.500
5140042	6	10	6.625	3.000

Dimensions are nominal

End Bell

Used in concrete vault walls to provide a smooth, safe entrance to the conduit outside. Protects wiring which is being pulled through the vault wall.

Meets requirements of NEMA TC-9

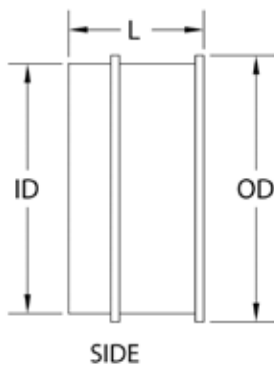

Part Number	Trade Size	Carton Qty.	"L"	"ID"	"OD"
5144003	1/2	100	1.000	.625	1.250
5144004	3/4	100	1.000	.875	1.500
5144005	1	50	1.250	1.063	1.750
5144006	1-1/4	50	1.313	1.375	2.125
5144007	1-1/2	50	1.563	1.625	2.500
5144008	2	40	1.563	2.063	2.813
5144009	2-1/2	30	1.875	2.500	3.375
5144010	3	50	2.063	3.000	4.125
5144011	3-1/2	50	2.250	3.500	4.625
5144012	4	50	2.375	4.000	5.125
5144013	5	25	2.438	5.063	6.375
5144014	6	15	2.875	6.063	7.375
5143987	*8	1	10.000	8.063	10.375

* 8 inch trade size is not UL Listed Dimensions are nominal

Schedule 40 / Schedule 80 Fittings & Accessories

Poly Plug

Part Number	Trade Size	Carton Qty.	"L"	"D-1"	"D-2"
5315248	2	70	3.250	1.875	2.438
5315250	3	70	3.813	2.625	3.438
5315252	4	90	4.063	3.688	4.438
5315253	5	45	3.813	4.750	5.500
5315254	6	30	3.813	5.563	6.500

Dimensions are nominal

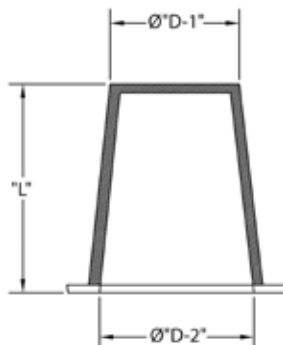

Poly Plug with Pulling Eye

Part Number	Trade Size	Carton Qty.	"L"	"D-1"	"D-2"
5315258	2	70	3.000	2.000	2.500
5315259	2 1/2	70	3.000	2.125	2.750
5315260	3	45	3.750	2.875	3.500
5315262	4	80	3.875	3.750	4.500
5315263	5	45	3.750	4.875	5.625
5315264	6	35	3.875	5.625	6.875

Dimensions are nominal

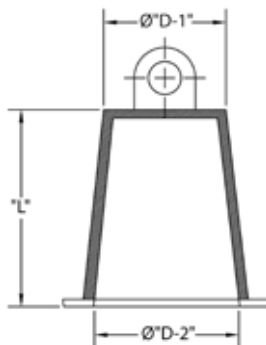

Pull Elbow

Part Number	Trade Size	Carton Qty.	"A"	"B"	"C"	"D"	"E"
5240100	1/2	75	2.125	2.625	1.500	.875	1.125
5240101	3/4	50	2.500	3.000	1.625	1.063	1.313

Dimensions are nominal

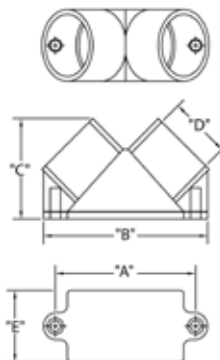

Schedule 40 / Schedule 80 Fittings & Accessories

Sealing Washer

Part Number	Trade Size	Carton Qty.	"ID"	"OD"	"T"
5163370	1/2	150	.880	1.200	.125
5163371	3/4	125	1.050	1.380	.125
5163372	1	100	1.340	1.650	.125
5163374	1-3/4	50	1.680	2.050	.125
5163373	1-1/2	25	1.900	2.280	.125
5163375	2	50	2.370	2.750	.125

Dimensions are nominal

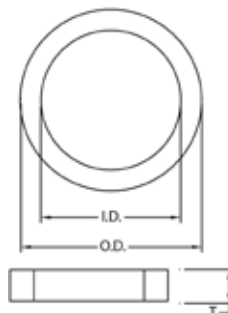

Use with terminal adapters for concrete tight connection.

Strain Relief Connectors

Part Number	Trade Size	Carton Qty.	"A" MIN IN ASSY	"B"	"C"	"DIA"
5133430	1/2	25	1.690	.910	.500	1.33
5133431	3/4	25	1.690	.910	.750	1.33

Dimensions are nominal

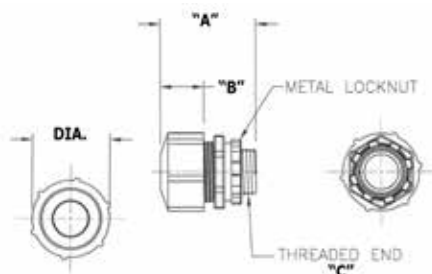

Threaded with lock nut and washer. Supplied with a set of 6 unique grommets for customer choice and use.

Insulating Bushing

Part Number	Trade Size	Carton Qty.	"A"	"B"
5134200U	1/2	10 Bags of 5	1.060	.430
5134201U	3/4	10 Bags of 5	1.310	.430
5134202U	1	10 Bags of 5	1.590	.480
5134203U	1-1/4	5 Bags of 5	1.960	.560
5134204U	1-1/2	5 Bags of 5	2.180	.560
5134205U	2	5 Bags of 5	2.680	.590
5134206U	2-1/2	10	3.250	.720
5134207U	3	10	3.870	.750

Dimensions are nominal

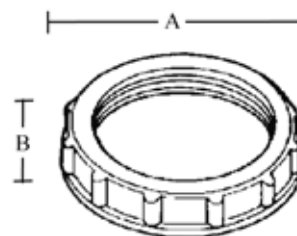

Schedule 40 / Schedule 80 Fittings & Accessories

Schedule 40 Longline Coupling with No Center Stop - Fabricated

Material is rigid PVC.

Part Number	Trade Size	Carton Qty.	"DIA"	"A"
6141702	1	20	1.313	4.500
6141703	1-1/2	20	1.875	4.875
6203000	2	20	2.375	6.125
6203002	2-1/2	20	2.875	6.125
6203005	3	25	3.563	6.125
6203006	3-1/2	25	4.000	6.375
6203007	4	15	4.500	6.500
6203009	5	8	5.688	8.000
6203010	6	4	6.688	8.000

Dimensions are nominal

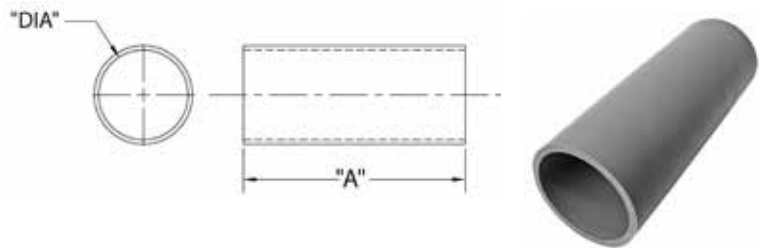

Schedule 40 Longline Coupling with Center Stop - Molded

Molded repair coupling with center stop. Material is rigid PVC.

Part Number	Trade Size	Carton Qty.	"DIA"	"A"	"B"
6202000	2	20	2.375	4.188	2.000
6202005	3	25	3.500	6.500	3.250
6202010	4	15	4.500	7.000	3.500

Dimensions are nominal

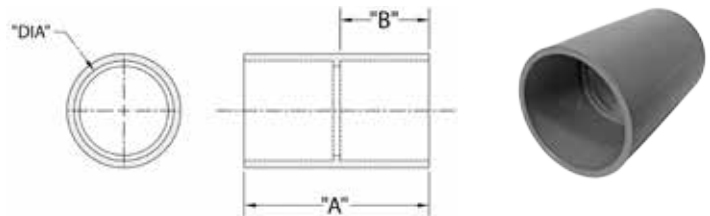

Schedule 40 Longline Coupling with Center Stop - Fabricated

Material is rigid PVC.

Part Number	Trade Size	Carton Qty.	"DIA"	"A"	"B"
6202002	2-1/2	25	2.875	6.313	2.750
6202015	5	8	5.563	8.313	3.625
6202016	6	4	6.625	9.000	3.500

Dimensions are nominal

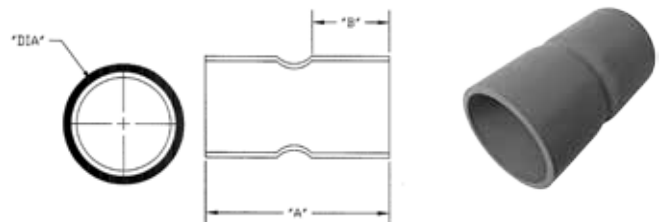

Schedule 40 Swedged Coupling with Center Stop - Fabricated

Material is rigid PVC.

Part Number	Trade Size	Carton Qty.	"DIA"	"A"	"B"
6201001	2	20	2.750	8.063	2.250
6201000	4	15	5.000	8.000	4.000
6151470	5	8	6.625	10.563	5.000
6141720	6	4	8.688	12.750	6.125

Dimensions are nominal

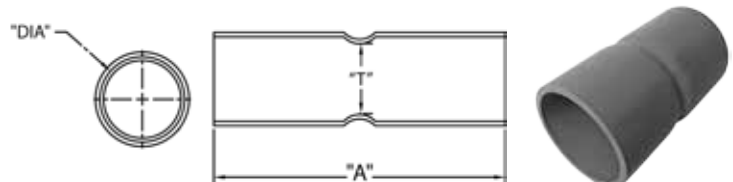

Schedule 40 / Schedule 80 Fittings & Accessories

Schedule 40 Split Sleeve Coupling - Fabricated



For repairs with wires in place.
Material is rigid PVC

Part Number	Trade Size	Carton Qty.	"DIA"	"A"
6141684	2	25	2.375	6.125
6141685	3	25	3.500	6.188
6141690	4	15	4.563	6.250
6141692	5	8	5.625	8.875
6141693	6	4	6.563	10.125

Dimensions are nominal

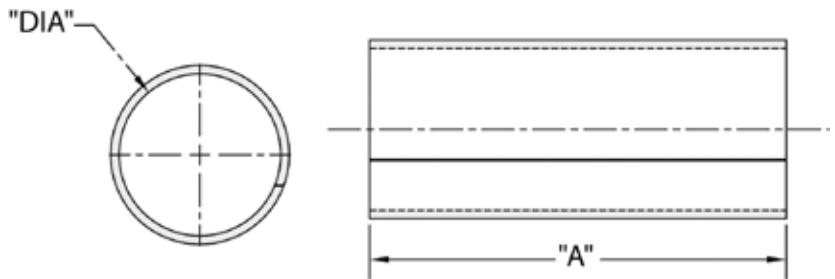

Schedule 40 End Bell - Fabricated



NEMA TC-9 Compliant
Material is rigid PVC

Part Number	Trade Size	Carton Qty.	"A"	"B"	"L"	"ID"	"OD"	"SD"
5143980	2	50	2.000	3.000	6.000 ± .25	2.390	2.750	3.000
5143982	3	50	2.000	3.000	6.000 ± .25	3.500	3.980	4.360
5143984	4	45	1.625	3.625	5.750 ± .25	4.500	5.125	5.250
5143986D	6	15	3.000	3.500	7.000 ± .25	6.625	7.313	5.750

Dimensions are nominal

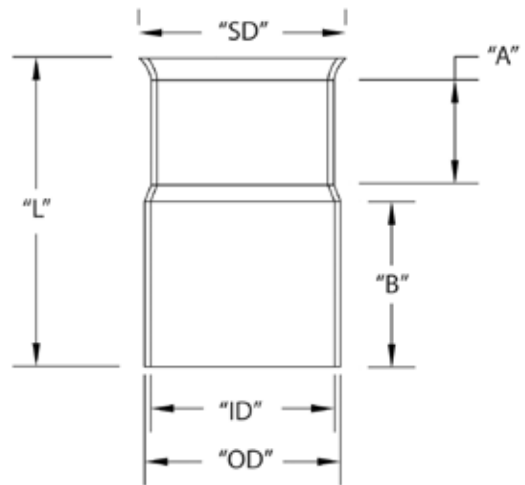

Rigid Nonmetallic Sch. 40 Elbows - Standard Radius

Schedule 40 90° Elbow - Plain End

Part Number	Trade Size	Carton Qty.	"R"	"O"	"H"	"S" MIN	"L"
5133823	1/2	50	4.000	4.000	4.000	1.500	6.250
5133824	3/4	35	4.500	4.500	4.500	1.500	7.125
5133825	1	20	5.750	5.750	5.750	1.875	9.000
5133826	1-1/4	30	7.250	7.250	7.250	2.000	11.375
5133827	1-1/2	30	8.250	8.250	8.250	2.000	13.000
5133828	2	15	9.500	9.500	9.500	2.000	15.000
5133829	2-1/2	18	10.500	10.500	10.500	3.000	16.500
5133830	3	14	13.000	13.000	13.000	3.125	20.375
5133831	3-1/2	12	15.000	15.000	15.000	3.250	23.500
5133832	4	10	16.000	16.000	16.000	3.375	25.125
5133835	5	30*	24.000	24.000	24.000	3.625	37.625
5133834	6	25*	30.000	30.000	30.000	3.750	47.125

* Pallet Quantity

Dimensions are nominal

Conforms to UL651 and NEMA TC3

Material is Rigid PVC

Bend Tolerance is $\pm 2^\circ$

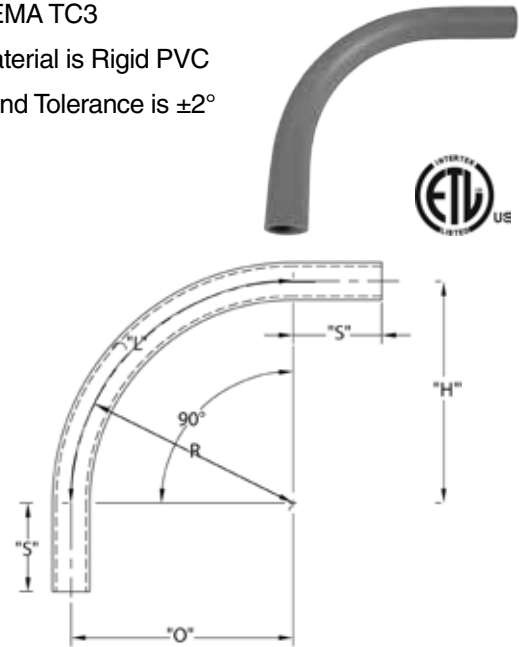

Schedule 40 45° Elbow - Plain End

Part Number	Trade Size	Carton Qty.	"R"	"O"	"H"	"S" MIN	"L"
5133763	1/2	50	4.000	1.188	2.875	1.500	3.125
5133764	3/4	25	4.500	1.313	3.188	1.500	3.500
5133765	1	20	5.750	1.688	4.000	1.875	4.500
5133766	1-1/4	25	7.250	2.125	5.125	2.000	5.688
5133767	1-1/2	20	8.250	2.375	5.875	2.000	6.500
5133768	2	10	9.500	2.813	6.750	2.000	7.500
5133769	2-1/2	20	10.500	2.563	7.375	3.000	8.250
5133770	3	8	13.000	3.813	9.188	3.125	10.250
5133771	3-1/2	5	15.000	4.375	10.625	3.250	11.875
5133772	4	20	16.000	4.688	11.438	3.375	12.625
5133773	5	30*	24.000	7.000	17.000	3.625	18.875
5133774	6	25*	30.000	8.813	21.250	3.750	22.875

* Pallet Quantity

Dimensions are nominal

Conforms to UL651 and NEMA TC3

Material is Rigid PVC

Bend Tolerance is $\pm 2^\circ$

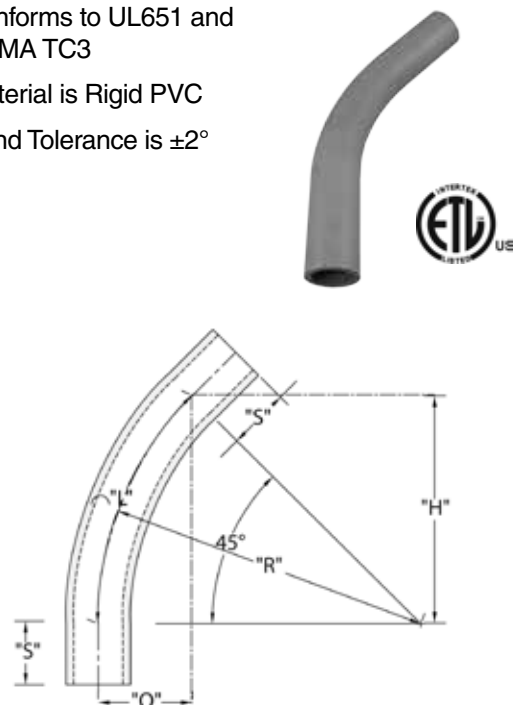

Rigid Nonmetallic Sch. 40 Elbows - Standard Radius

Schedule 40 30° Elbow - Plain End

Conforms to UL651 and NEMA TC3

Material is Rigid PVC

Bend Tolerance is $\pm 2^\circ$

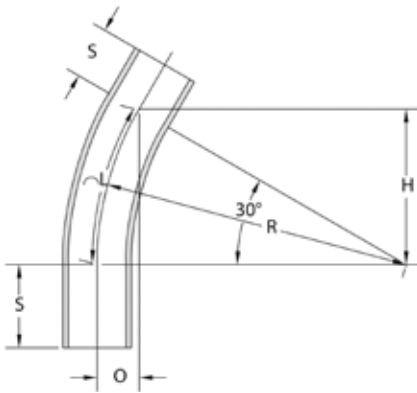

Part Number	Trade Size	Carton Qty.	"R"	"O"	"H"	"S" MIN	"L"
5133755	1/2	50	4.000	.500	2.000	1.500	2.125
5133744	3/4	25	4.500	.625	2.250	1.500	2.375
5133745	1	20	5.750	.750	2.875	1.875	3.000
5133746	1-1/4	25	7.250	1.000	3.625	2.000	3.813
5133747	1-1/2	20	8.250	1.063	4.125	2.000	4.313
5133748	2	10	9.500	1.250	4.750	2.000	5.000
5133749	2-1/2	20	10.500	1.438	5.250	3.000	5.500
5133750	3	8	13.000	1.750	6.500	3.125	6.813
5133751	3-1/2	5	15.000	2.000	7.563	3.250	7.875
5133775	4	20	16.000	2.063	8.000	3.375	8.375
5133753	5	30*	24.000	3.188	12.000	3.625	12.563
5133754	6	25*	30.000	4.000	15.000	3.750	15.688

* Pallet Quantity

Dimensions are nominal

Schedule 40 22-1/2° Elbow - Plain End

Conforms to UL651 and NEMA TC3

Material is Rigid PVC

Bend Tolerance is $\pm 2^\circ$

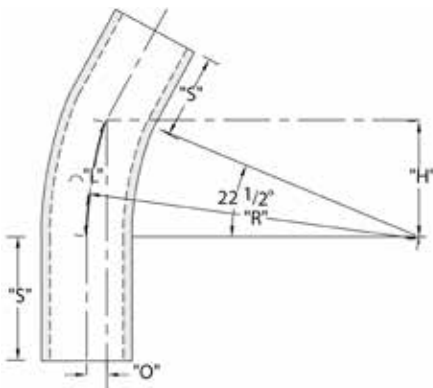

Part Number	Trade Size	Carton Qty.	"R"	"O"	"H"	"S" MIN	"L"
5136403	1-1/4	25	7.250	.563	2.750	2.000	2.875
5134094	1-1/2	25	8.250	.625	3.125	2.000	3.250
5134067	2	10	9.500	.750	3.625	2.000	3.750
5134096	2-1/2	20	10.500	.813	4.000	3.000	4.125
5134068	3	8	13.000	1.000	5.000	3.125	5.125
5134095	3-1/2	5	15.000	1.125	5.750	3.250	5.875
5133757	4	20	16.000	1.250	6.125	3.375	6.250
5134037	5	60*	24.000	1.813	9.188	3.625	9.375
5133901	6	50*	30.000	2.250	11.500	3.750	11.750

* Pallet Quantity

Dimensions are nominal

Rigid Nonmetallic Sch. 40 Elbows - Standard Radius

Schedule 40 90° Elbow - Bell End

Part Number	Trade Size	Carton Qty.	"R"	"O"	"H"	"S" MIN	"B" MIN	"L"
5233823	1/2	50	4.000	4.000	4.000	1.500	1.000	6.250
5233824	3/4	35	4.500	4.500	4.500	1.500	1.500	7.125
5233825	1	20	5.750	5.75	5.75	1.875	1.500	9.000
5233826	1-1/4	30	7.250	7.250	7.250	2.000	1.500	11.375
5233827	1-1/2	30	8.250	8.250	8.250	2.000	2.000	13.000
5233828	2	15	9.500	9.500	9.500	2.000	2.000	15.000
5233829	2-1/2	18	10.500	10.500	10.500	3.000	2.250	16.500
5233830	3	14	13.000	13.000	13.000	3.125	2.500	20.375
5233831	3-1/2	12	15.000	15.000	15.000	3.250	3.250	23.500
5233832	4	10	16.000	16.000	16.000	3.375	3.250	25.125
5233835	5	30*	24.000	24.000	24.000	3.625	4.250	37.625
5233834	6	25*	30.000	30.000	30.000	3.750	5.000	47.125

* Pallet Quantity

Dimensions are nominal

Conforms to UL651 and NEMA TC3

Material is Rigid PVC

Bend Tolerance is $\pm 2^\circ$

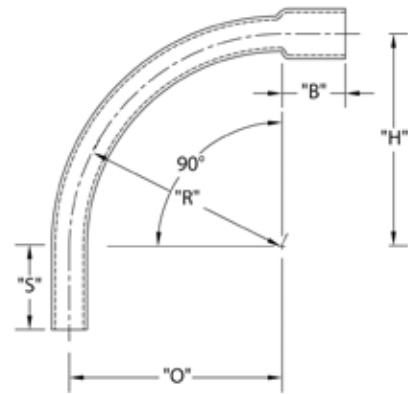

Schedule 40 45° Elbow - Bell End

Part Number	Trade Size	Carton Qty.	"R"	"O"	"H"	"S" MIN	"B" MIN	"L"
5233763	1/2	50	4.000	1.188	2.813	1.500	1.000	3.125
5233764	3/4	25	4.500	1.313	3.188	1.500	1.500	3.500
5233765	1	20	5.750	1.688	4.063	1.875	1.500	4.500
5233766	1-1/4	25	7.250	2.125	5.125	2.000	1.500	5.688
5233767	1-1/2	25	8.250	2.438	5.813	2.000	2.000	6.500
5233768	2	10	9.500	2.813	6.750	2.000	2.000	7.500
5233769	2-1/2	20	10.500	3.063	7.438	3.000	2.250	8.250
5233770	3	8	13.000	3.813	9.188	3.500	2.500	10.188
5233771	3-1/2	5	15.000	4.375	10.625	3.250	3.250	11.813
5233772	4	20	16.000	4.688	11.188	3.375	3.250	12.563
5233773	5	30*	24.000	7.000	17.000	3.625	4.250	18.875
5233774	6	25*	30.000	8.875	21.250	3.750	5.000	23.563

* Pallet Quantity

Dimensions are nominal

Conforms to UL651 and NEMA TC3

Material is Rigid PVC

Bend Tolerance is $\pm 2^\circ$

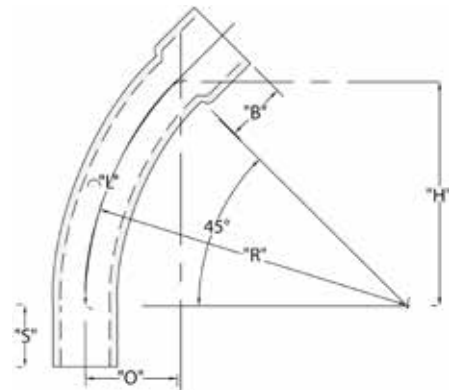

Rigid Nonmetallic Sch. 40 Elbows - Standard Radius

Schedule 40 30° Elbow - Bell End

Conforms to UL651 and NEMA TC3

Material is Rigid PVC

Bend Tolerance is $\pm 2^\circ$

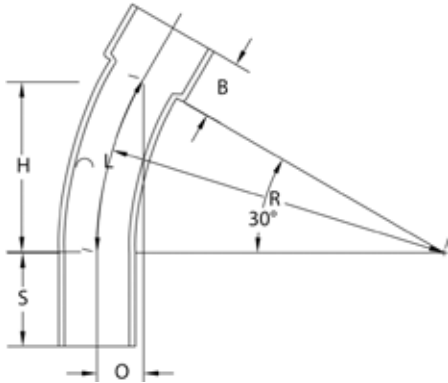

Part Number	Trade Size	Carton Qty.	"R"	"O"	"H"	"S" MIN	"B" MIN	"L"
5233748	2	10	9.500	1.250	4.750	2.000	2.000	5.000
5233750	3	8	13.000	1.750	6.500	3.125	2.500	6.813
5233751	3-1/2	5	15.000	2.000	7.563	3.250	3.250	7.875
5233776	4	20	16.000	2.063	8.000	3.375	3.250	8.375
5233753	5	30*	24.000	3.188	12.000	3.625	4.250	12.563
5233754	6	50*	30.000	4.000	15.000	3.750	5.00	15.688

* Pallet Quantity

Dimensions are nominal

Schedule 40 22-1/2° Elbow - Bell End

Conforms to UL651 and NEMA TC3

Material is Rigid PVC

Bend Tolerance is $\pm 2^\circ$

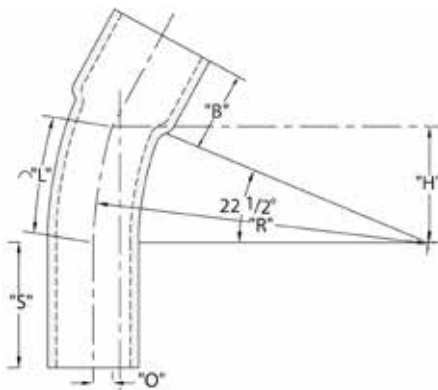

Part Number	Trade Size	Carton Qty.	"R"	"O"	"H"	"S" MIN	"B" MIN	"L"
5234097	3/4	25	4.500	.375	1.750	1.500	1.500	1.750
5236402	1	20	5.750	.313	2.188	1.875	1.500	2.250
5236403	1-1/4	25	7.250	.563	2.750	2.000	1.500	2.875
5234094	1-1/2	20	8.250	.625	3.125	2.000	2.000	3.250
5234067	2	10	9.500	.750	3.625	2.000	2.000	3.750
5234096	2-1/2	10	10.500	.813	4.000	3.000	2.250	4.125
5234068	3	8	13.000	1.000	5.000	3.125	2.500	5.125
5234095	3-1/2	5	15.000	1.125	5.750	3.250	3.250	5.875
5233867	4	20	16.000	1.250	6.125	3.375	3.250	6.250
5234037	5	60*	24.000	1.813	9.188	3.625	4.250	9.375
5233901	6	50*	30.000	2.250	11.500	3.750	5.000	11.750

* Pallet Quantity

Dimensions are nominal

Rigid Nonmetallic Sch. 40 Elbows - Special Radius

Schedule 40 90° Elbow Special Radius - Plain End

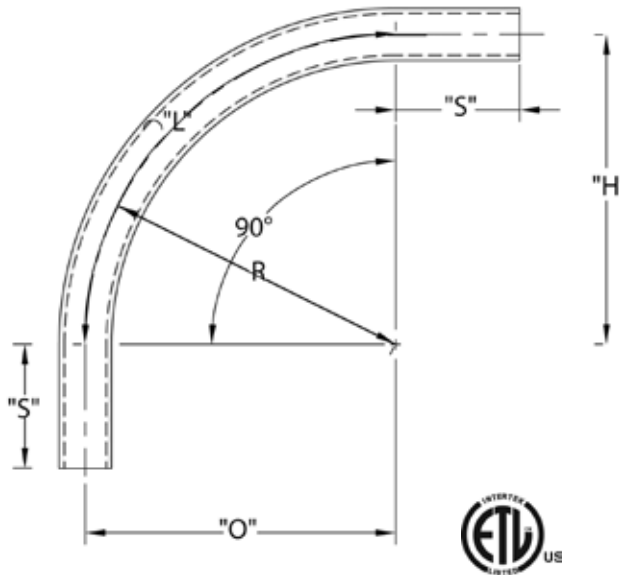

Schedule 40 90° Elbow 18" Radius Plain End

Part Number	Trade Size	"R"	"O"	"H"	"S" MIN	"L"
5133846	1	18	18	18	1.875	28.250
5133923	1-1/4	18	18	18	2.000	28.250
5133839	1-1/2	18	18	18	2.000	28.250
5133844	2	18	18	18	2.000	28.250
5133856	2-1/2	18	18	18	3.000	28.250
5133858	3	18	18	18	3.125	28.250

Dimensions are nominal

Schedule 40 90° Elbow 24" Radius Plain End

Part Number	Trade Size	"R"	"O"	"H"	"S" MIN	"L"
5133934	3/4	24	24	24	1.500	37.750
5133859	1	24	24	24	1.875	37.750
5133883	1-1/4	24	24	24	2.000	37.750
5133873	1-1/2	24	24	24	2.000	37.750
5133836	2	24	24	24	2.000	37.750
5133847	2-1/2	24	24	24	3.000	37.750
5133837	3	24	24	24	3.125	37.750
5133893	3-1/2	24	24	24	3.250	37.750
5133822	4	24	24	24	3.375	37.750

Dimensions are nominal

Schedule 40 90° Elbow 30" Radius Plain End

Part Number	Trade Size	"R"	"O"	"H"	"S" MIN	"L"
5134147	3/4	30	30	30	1.500	47.125
5136340	1	30	30	30	1.875	47.125
5133878	1-1/4	30	30	30	2.000	47.125
5133921	1-1/2	30	30	30	2.000	47.125
5133920	2	30	30	30	2.000	47.125
5133981	2-1/2	30	30	30	3.000	47.125
5133867	3	30	30	30	3.125	47.125
5133948	3-1/2	30	30	30	3.250	47.125
5133850	4	30	30	30	3.375	47.125
5133872	5	30	30	30	3.625	47.125

Dimensions are nominal

Schedule 40 90° Elbow 36" Radius Plain End

Part Number	Trade Size	"R"	"O"	"H"	"S" MIN	"L"
5133949	3/4	36	36	36	1.500	56.500
5133852	1	36	36	36	1.875	56.500
5133884	1-1/4	36	36	36	2.000	56.500
5133866	1-1/2	36	36	36	2.000	56.500
5133848	2	36	36	36	2.000	56.500
5133857	2-1/2	36	36	36	3.000	56.500
5133820	3	36	36	36	3.125	56.500
5133818	3-1/2	36	36	36	3.250	56.500
5133821	4	36	36	36	3.375	56.500
5133841	5	36	36	36	3.625	56.500
5133877	6	36	36	36	3.750	56.500

Dimensions are nominal

Schedule 40 90° Elbow 48" Radius Plain End

Part Number	Trade Size	"R"	"O"	"H"	"S" MIN	"L"
5133864	1	48	48	48	1.875	75.375
5133871	1-1/4	48	48	48	2.000	75.375
5133865	1-1/2	48	48	48	2.000	75.375
5133876	2	48	48	48	2.000	75.375
5133849	2-1/2	48	48	48	3.000	75.375
5133817	3	48	48	48	3.125	75.375
5133892	3-1/2	48	48	48	3.250	75.375
5133843	4	48	48	48	3.375	75.375
5133842	5	48	48	48	3.625	75.375
5133816	6	48	48	48	3.750	75.375
5133993D	8	48	48	48	6.625	75.375

Dimensions are nominal

Rigid Nonmetallic Sch. 40 Elbows - Special Radius

Schedule 40 90° Elbow Special Radius - Plain End

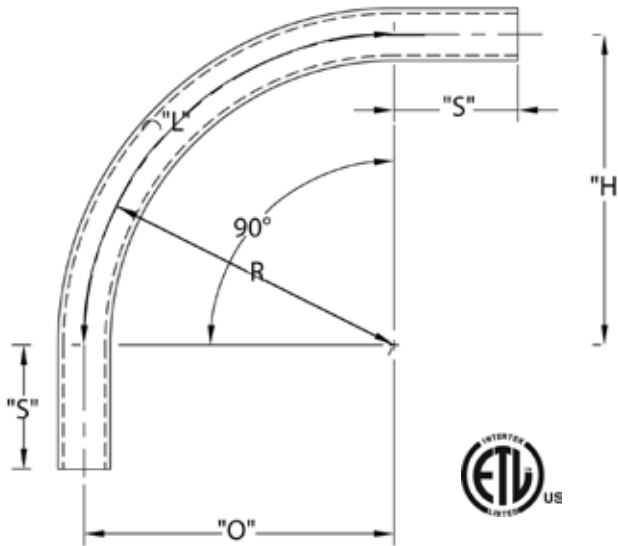

Schedule 40 90° Elbow 60" Radius Plain End

Part Number	Trade Size	"R"	"O"	"H"	"S" MIN	"L"
5133786	2	60	60	60	2.000	94.250
5134046	2-1/2	60	60	60	3.000	94.250
5133819	3	60	60	60	3.125	94.250
5133925	3-1/2	60	60	60	3.250	94.250
5133854	4	60	60	60	3.375	94.250
5133885	5	60	60	60	3.625	94.250
5133886	6	60	60	60	3.750	94.250

Dimensions are nominal

Schedule 40 90° Elbow 72" Radius Plain End

Part Number	Trade Size	"R"	"O"	"H"	"S" MIN	"L"
5133860	2	72	72	72	2.000	113.125
5134155	3	72	72	72	3.125	113.125
5133787	4	72	72	72	3.375	113.125
5134024	5	72	72	72	3.625	113.125
5133928	6	72	72	72	3.750	113.125

Dimensions are nominal

Schedule 40 90° Elbow 84" Radius Plain End

Part Number	Trade Size	"R"	"O"	"H"	"S" MIN	"L"
5134049	6	84	84	84	3.75	132

Dimensions are nominal

Schedule 40 90° Elbow 96" Radius Plain End

Part Number	Trade Size	"R"	"O"	"H"	"S" MIN	"L"
5134025	5	96	96	96	3.625	150.875
5134015	6	96	96	96	3.750	150.875

Dimensions are nominal

Schedule 40 90° Elbow 120" Radius Plain End

Part Number	Trade Size	"R"	"O"	"H"	"S" MIN	"L"
5133927	4	120	120	120	3.375	188.500
5134007	6	120	120	120	3.750	188.500

Dimensions are nominal

Schedule 40 90° Elbow 150" Radius Plain End

Part Number	Trade Size	"R"	"O"	"H"	"S" MIN	"L"
5133992	4	150	150	150	3.375	235.625
5134059	5	150	150	150	3.625	235.625

Dimensions are nominal

Rigid Nonmetallic Sch. 40 Elbows - Special Radius

Schedule 40 45° Elbow Special Radius - Plain End

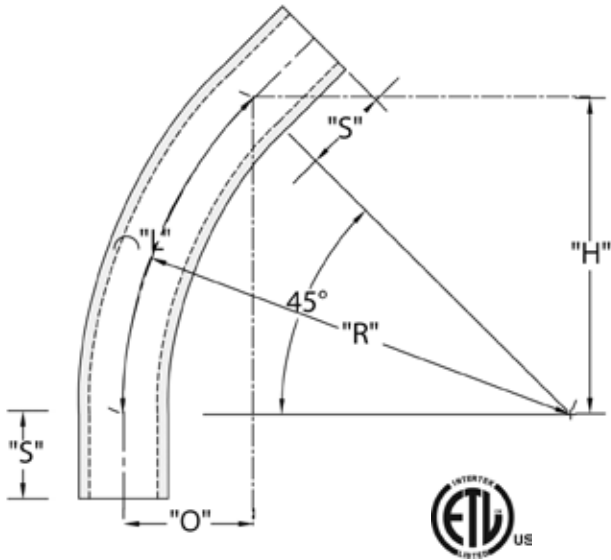

Schedule 40 45° Elbow 30" Radius Plain End

Part Number	Trade Size	"R"	"O"	"H"	"S" MIN	"L"
5136341	1	30.000	8.688	21.250	1.875	2.563
5136348	1-1/2	30.000	8.688	21.250	2.000	2.563
5133918	2	30.000	8.688	21.250	2.000	2.563
5133896	2-1/2	30.000	8.688	21.250	3.000	2.563
5133897	3	30.000	8.688	21.250	3.125	2.563
5133953	4	30.000	8.688	21.250	3.375	2.563
5133954	5	30.000	8.688	21.250	3.625	2.563

Dimensions are nominal

Schedule 40 45° Elbow 36" Radius Plain End

Part Number	Trade Size	"R"	"O"	"H"	"S" MIN	"L"
5133950	3/4	36.000	10.500	25.500	1.500	28.250
5133919	1	36.000	10.500	25.500	1.875	28.250
5133956	1-1/4	36.000	10.500	25.500	2.000	28.250
5133810	1-1/2	36.000	10.500	25.500	2.000	28.250
5133778	2	36.000	10.500	25.500	2.000	28.250
5133801	2-1/2	36.000	10.500	25.500	3.000	28.250
5133779	3	36.000	10.500	25.500	3.125	28.250
5133939	3-1/2	36.000	10.500	25.500	3.250	28.250
5133777	4	36.000	10.500	25.500	3.375	28.250
5133780	5	36.000	10.500	25.500	3.625	28.250
5133880	6	36.000	10.500	25.500	3.750	28.250
5133988D	8*	36.000	10.500	25.500	6.625	28.250

*Not ETL Listed

Dimensions are nominal

Schedule 40 45° Elbow 18" Radius Plain End

Part Number	Trade Size	"R"	"O"	"H"	"S" MIN	"L"
5134008	1	18.000	5.250	12.75	1.875	14.125
5136344	1-1/4	18.000	5.250	12.75	2.000	14.125
5133840	1-1/2	18.000	5.250	12.75	2.000	14.125
5133797	2	18.000	5.250	12.75	2.000	14.125
5133973	2-1/2	18.000	5.250	12.75	3.000	14.125
5133799	3	18.000	5.250	12.75	3.125	14.125

Dimensions are nominal

Schedule 40 45° Elbow 24" Radius Plain End

Part Number	Trade Size	"R"	"O"	"H"	"S" MIN	"L"
5133933	3/4	24.000	17.000	7.000	1.500	18.875
5133875	1	24.000	17.000	7.000	1.875	18.875
5133941	1-1/4	24.000	17.000	7.000	2.000	18.875
5133874	1-1/2	24.000	17.000	7.000	2.000	18.875
5133815	2	24.000	17.000	7.000	2.000	18.875
5133935	2-1/2	24.000	17.000	7.000	3.000	18.875
5133800	3	24.000	17.000	7.000	3.125	18.875
5133802	3-1/2	24.000	17.000	7.000	3.250	18.875
5133812	4	24.000	17.000	7.000	3.375	18.875

Dimensions are nominal

Schedule 40 45° Elbow 48" Radius Plain End

Part Number	Trade Size	"R"	"O"	"H"	"S" MIN	"L"
5133940	1	48.000	14.000	34.000	1.875	37.688
5133942	1-1/4	48.000	14.000	34.000	2.000	37.688
5133811	1-1/2	48.000	14.000	34.000	2.000	37.688
5133798	2	48.000	14.000	34.000	2.000	37.688
5134010	2-1/2	48.000	14.000	34.000	3.000	37.688
5133781	3	48.000	14.000	34.000	3.125	37.688
5133979	3-1/2	48.000	14.000	34.000	3.250	37.688
5133776	4	48.000	14.000	34.000	3.375	37.688
5133814	5	48.000	14.000	34.000	3.625	37.688
5133813	6	48.000	14.000	34.000	3.750	37.688
5133989D	8*	48.000	14.000	34.000	6.625	37.688

*Not ETL Listed

Dimensions are nominal

Rigid Nonmetallic Sch. 40 Elbows - Special Radius

Schedule 40 45° Elbow Special Radius - Plain End

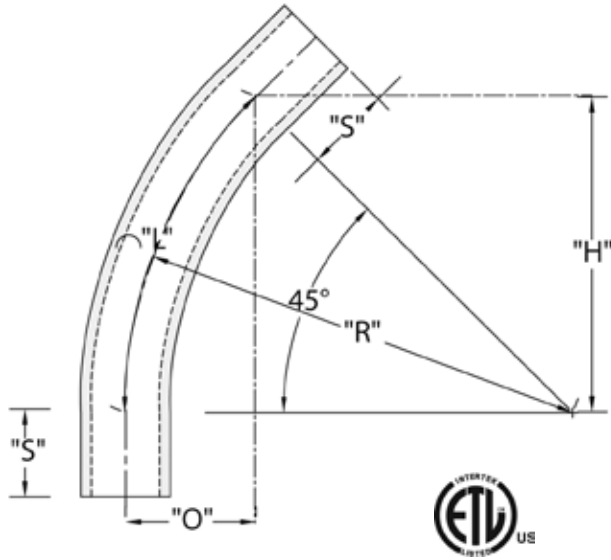

Schedule 40 45° Elbow 60" Radius Plain End

Part Number	Trade Size	"R"	"O"	"H"	"S" MIN	"L"
5133808	2	60.000	17.625	34.000	2.000	47.125
5134111	2-1/2	60.000	17.625	34.000	3.000	47.125
5134006	3	60.000	17.625	34.000	3.125	47.125
5133946	4	60.000	17.625	34.000	3.375	47.125
5133947	5	60.000	17.625	34.000	3.625	47.125
5133806	6	60.000	17.625	34.000	6.750	47.125
5133980	8	60.000	17.625	34.000	6.625	47.125

Dimensions are nominal

Schedule 40 45° Elbow 72" Radius Plain End

Part Number	Trade Size	"R"	"O"	"H"	"S" MIN	"L"
5134128	3	72.000	21.000	50.938	3.125	56.500
5134153	5	72.000	21.000	50.938	3.625	56.500
5133868	6	72.000	21.000	50.938	3.750	56.500

Dimensions are nominal

Schedule 40 45° Elbow 84" Radius Plain End

Part Number	Trade Size	"R"	"O"	"H"	"S" MIN	"L"
5133783	4	84.000	24.625	59.375	3.375	66.000

Dimensions are nominal

Schedule 40 45° Elbow 96" Radius Plain End

Part Number	Trade Size	"R"	"O"	"H"	"S" MIN	"L"
5133785	4	96.000	28.125	67.875	3.375	75.375
5134027	5	96.000	28.125	67.875	3.625	75.375
5134086	6	96.000	28.125	67.875	3.750	75.375
5134100	8	96.000	28.125	67.875	6.625	75.375

Dimensions are nominal

Schedule 40 45° Elbow 120" Radius Plain End

Part Number	Trade Size	"R"	"O"	"H"	"S" MIN	"L"
5125886	4	120.000	35.188	84.875	3.375	94.250

Dimensions are nominal

Rigid Nonmetallic Sch. 40 Elbows - Special Radius

Schedule 40 30° Elbow Special Radius - Plain End

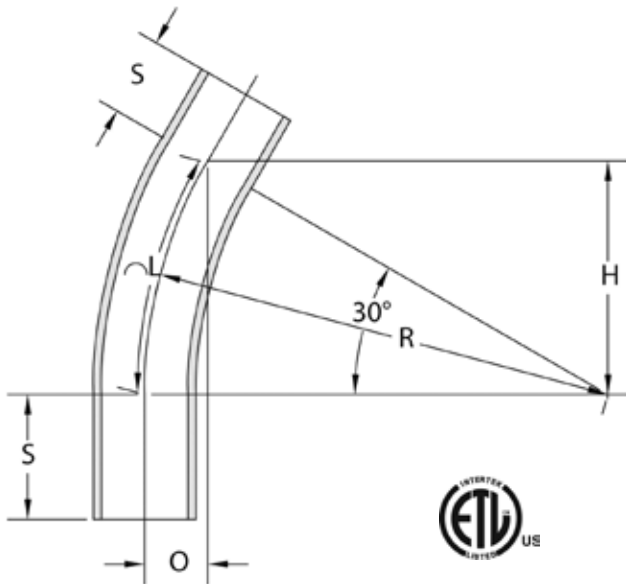

Schedule 40 30° Elbow 36" Radius Plain End

Part Number	Trade Size	"R"	"O"	"H"	"S" MIN	"L"
5136347	1-1/4	36.000	4.813	18.000	2.000	18.875
5133974	1-1/2	36.000	4.813	18.000	2.000	18.875
5133792	2	36.000	4.813	18.000	2.000	18.875
5133807	2-1/2	36.000	4.813	18.000	3.000	18.875
5133793	3	36.000	4.813	18.000	3.125	18.875
5133938	3-1/2	36.000	4.813	18.000	3.250	18.875
5133790	4	36.000	4.813	18.000	3.375	18.875
5133931	5	36.000	4.813	18.000	3.625	18.875
5133791	6	36.000	4.813	18.000	3.750	18.875

Dimensions are nominal

Schedule 40 30° Elbow 48" Radius Plain End

Part Number	Trade Size	"R"	"O"	"H"	"S" MIN	"L"
5136343	1	48.000	6.438	24.000	1.875	25.125
5133943	1-1/4	48.000	6.438	24.000	2.000	25.125
5133982	1-1/2	48.000	6.438	24.000	2.000	25.125
5133805	2	48.000	6.438	24.000	2.000	25.125
5133809	3	48.000	6.438	24.000	3.125	25.125
5134026	3-1/2	48.000	6.438	24.000	3.250	25.125
5133838	4	48.000	6.438	24.000	3.375	25.125
5133959	5	48.000	6.438	24.000	3.625	25.125
5133861	6	48.000	6.438	24.000	3.750	25.125

Dimensions are nominal

Schedule 40 30° Elbow 18" Radius Plain End

Part Number	Trade Size	"R"	"O"	"H"	"S" MIN	"L"
5133916	1	18.000	2.438	9.063	1.875	9.438
5133794	1-1/4	18.000	2.438	9.063	2.000	9.438
5133917	1-1/2	18.000	2.438	9.063	2.000	9.438
5133789	2	18.000	2.438	9.063	2.000	9.438
5133752	2-1/2	18.000	2.438	9.063	3.000	9.438
5133969	3	18.000	2.438	9.063	3.125	9.438

Dimensions are nominal

Schedule 40 30° Elbow 24" Radius Plain End

Part Number	Trade Size	"R"	"O"	"H"	"S" MIN	"L"
5136435	1	24.000	3.188	12.000	1.875	12.563
5133913	1-1/4	24.000	3.188	12.000	2.000	12.563
5133803	1-1/2	24.000	3.188	12.000	2.000	12.563
5133796	2	24.000	3.188	12.000	2.000	12.563
5133957	2-1/2	24.000	3.188	12.000	3.000	12.563
5133958	3	24.000	3.188	12.000	3.125	12.563
5136439	3-1/2	24.000	3.188	12.000	3.250	12.563
5133788	4	24.000	3.188	12.000	3.375	12.563

Dimensions are nominal

Schedule 40 30° Elbow 60" Radius Plain End

Part Number	Trade Size	"R"	"O"	"H"	"S" MIN	"L"
5134162	2	60	8.063	30.000	2.000	31.438
5136496	3	60	8.063	30.000	3.125	31.438
5133999	4	60	8.063	30.000	3.375	31.438
5133962	5	60	8.063	30.000	3.625	31.438
5133782	6	60	8.063	30.000	3.750	31.438

Dimensions are nominal

Schedule 40 30° Elbow 30" Radius Plain End

Part Number	Trade Size	"R"	"O"	"H"	"S" MIN	"L"
5136495	3	30.000	4.000	15.000	3.125	15.688
5133898	4	30.000	4.000	15.000	3.375	15.688

Dimensions are nominal

Schedule 40 30° Elbow 150" Radius Plain End

Part Number	Trade Size	"R"	"O"	"H"	"S" MIN	"L"
5134121	2	150	75.000	2.000	2.000	78.563
5134058	4	150	75.000	2.000	3.375	78.563
5134001	5	150	75.000	2.000	3.625	78.563

Dimensions are nominal

Rigid Nonmetallic Sch. 40 Elbows - Special Radius

Schedule 40 22-1/2° Elbow Special Radius - Plain End

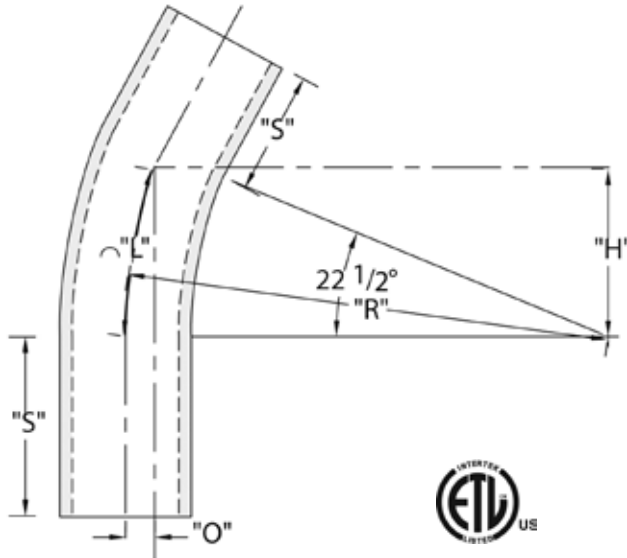

Schedule 40 22-1/2° Elbow 36" Radius Plain End

Part Number	Trade Size	"R"	"O"	"H"	"S" MIN	"L"
5133975	1	36.000	2.750	13.750	1.875	14.125
5133997	1-1/4	36.000	2.750	13.750	2.000	14.125
5134103	1-1/2	36.000	2.750	13.750	2.000	14.125
5133851	2	36.000	2.750	13.750	2.000	14.125
5133937	2-1/2	36.000	2.750	13.750	3.000	14.125
5133904	3	36.000	2.750	13.750	3.125	14.125
5136437	3-1/2	36.000	2.750	13.750	3.250	14.125
5133853	4	36.000	2.750	13.750	3.375	14.125
5133881	5	36.000	2.750	13.750	3.625	14.125
5133905	6	36.000	2.750	13.750	3.750	14.125

Dimensions are nominal

Schedule 40 22-1/2° Elbow 48" Radius Plain End

Part Number	Trade Size	"R"	"O"	"H"	"S" MIN	"L"
5136431	1-1/2	48.000	3.625	1.375	3.000	18.875
5133984	2	48.000	3.625	1.375	3.125	18.875
5136434	2-1/2	48.000	3.625	1.375	3.000	18.875
5133971	3	48.000	3.625	1.375	3.250	18.875
5133932	4	48.000	3.625	1.375	3.625	18.875
5133930	5	48.000	3.625	1.375	3.750	18.875
5133862	6	48.000	3.625	1.375	6.625	18.875

Dimensions are nominal

Schedule 40 22-1/2° Elbow 18" Radius Plain End

Part Number	Trade Size	"R"	"O"	"H"	"S" MIN	"L"
5133944	1	18.000	1.375	6.875	1.875	7.063
5136424	1-1/4	18.000	1.375	6.875	2.000	7.063
5133908	1-1/2	18.000	1.375	6.875	2.000	7.063
5133879	2	18.000	1.375	6.875	2.000	7.063
5133936	2-1/2	18.000	1.375	6.875	3.000	7.063
5133845	3	18.000	1.375	6.875	3.125	7.063

Dimensions are nominal

Schedule 40 22-1/2° Elbow 60" Radius Plain End

Part Number	Trade Size	"R"	"O"	"H"	"S" MIN	"L"
5134012	4	60	4.563	23.000	3.375	23.563
5134020	5	60	4.563	23.000	3.625	23.563
5134065	6	60	4.563	23.000	3.750	23.563

Dimensions are nominal

Schedule 40 22-1/2° Elbow 24" Radius Plain End

Part Number	Trade Size	"R"	"O"	"H"	"S" MIN	"L"
5136420	1	24.000	1.813	9.188	1.875	9.438
5136425	1-1/4	24.000	1.813	9.188	2.000	9.438
5136428	1-1/2	24.000	1.813	9.188	2.000	9.438
5133915	2	24.000	1.813	9.188	2.000	9.438
5134019	2-1/2	24.000	1.813	9.188	3.000	9.438
5133903	3	24.000	1.813	9.188	3.125	9.438
5133902	3-1/2	24.000	1.813	9.188	3.250	9.438
5133869	4	24.000	1.813	9.188	3.375	9.438

Dimensions are nominal

Schedule 40 22-1/2° Elbow 120" Radius Plain End

Part Number	Trade Size	"R"	"O"	"H"	"S" MIN	"L"
5133887	2	120	9.125	45.938	2.000	47.125
5134175	4	120	9.125	45.938	3.375	47.125
5134117	5	120	9.125	45.938	3.625	47.125

Dimensions are nominal

Schedule 40 22-1/2° Elbow 30" Radius Plain End

Part Number	Trade Size	"R"	"O"	"H"	"S" MIN	"L"
5136421	1	30.000	2.25	11.500	1.875	11.750
5136433	2-1/2	30.000	2.25	11.500	3.000	11.750
5133929	3	30.000	2.25	11.500	3.125	11.750
5133882	4	30.000	2.25	11.500	3.375	11.750
5133900	5	30.000	2.25	11.500	3.625	11.750

Dimensions are nominal

Schedule 40 22-1/2° Elbow 150" Radius Plain End

Part Number	Trade Size	"R"	"O"	"H"	"S" MIN	"L"
5134002	2-1/2	150	11.375	57.375	3.000	58.875
5133945	4	150	11.375	57.375	3.375	58.875
5133960	5	150	11.375	57.375	3.625	58.875
5134055	6	150	11.375	57.375	3.750	58.875

Dimensions are nominal

Rigid Nonmetallic Sch. 40 Elbows - Special Radius

Schedule 40 11-1/4° Elbow Special Radius - Plain End

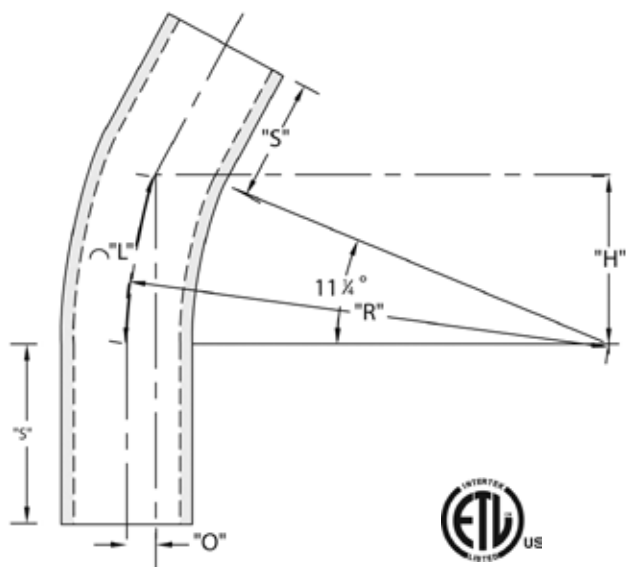

Schedule 40 11-1/4° Elbow 18" Radius Plain End

Part Number	Trade Size	"R"	"O"	"H"	"S" MIN	"L"
5134034	2	18.000	.344	3.500	2.000	3.500
5134035	3	18.000	1.375	3.500	3.125	3.500

Dimensions are nominal

Schedule 40 11-1/4° Elbow 24" Radius Plain End

Part Number	Trade Size	"R"	"O"	"H"	"S" MIN	"L"
5134152	2	24.000	.469	9.188	2.000	1.688
5134036	3	24.000	.469	9.188	3.125	1.688
5133991	4	24.000	.469	9.188	3.250	1.688
5133965	5	24.000	.469	9.188	3.375	1.688

Dimensions are nominal

Schedule 40 11-1/4° Elbow 36" Radius Plain End

Part Number	Trade Size	"R"	"O"	"H"	"S" MIN	"L"
5133996	1-1/4	36.000	.688	7.000	2.000	7.063
5133963	2	36.000	.688	7.000	2.000	7.063
5134129	2-1/2	36.000	.688	7.000	3.000	7.063
5134082	3	36.000	.688	7.000	3.125	7.063
5133910	4	36.000	.688	7.000	3.375	7.063
5133914	5	36.000	.688	7.000	3.625	7.063
5133987	6	36.000	.688	7.000	3.750	7.063

Dimensions are nominal

Schedule 40 11-1/4° Elbow 48" Radius Plain End

Part Number	Trade Size	"R"	"O"	"H"	"S" MIN	"L"
5133998	1-1/4	48.000	.938	9.375	2.000	9.438
5134039	2-1/2	48.000	.938	9.375	3.000	9.438
5134083	3	48.000	.938	9.375	3.125	9.438
5133990	4	48.000	.938	9.375	3.375	9.438
5133977	5	48.000	.938	9.375	3.625	9.438
5134079	6	48.000	.938	9.375	3.750	9.438
5133907	8	48.000	.938	9.375	6.625	9.438

Dimensions are nominal

Schedule 40 11-1/4° Elbow 60" Radius Plain End

Part Number	Trade Size	"R"	"O"	"H"	"S" MIN	"L"
5134084	3	60	1.125	11.688	3.125	11.750
5134157	4	60	1.125	11.688	3.375	11.750
5133978	5	60	1.125	11.688	3.625	11.750
5134080	6	60	1.125	11.688	3.750	11.750

Dimensions are nominal

Schedule 40 11-1/4° Elbow 72" Radius Plain End

Part Number	Trade Size	"R"	"O"	"H"	"S" MIN	"L"
5134070	5	72	1.375	14.000	3.625	14.125
5134143	6	72	1.375	14.000	3.750	14.125

Dimensions are nominal

Schedule 40 11-1/4° Elbow 120" Radius Plain End

Part Number	Trade Size	"R"	"O"	"H"	"S" MIN	"L"
5134151	5	120.000	23.000	23.438	3.625	23.563

Dimensions are nominal

Schedule 40 11-1/4° Elbow 150" Radius Plain End

Part Number	Trade Size	"R"	"O"	"H"	"S" MIN	"L"
5133911	2	150	2.875	29.250	2.000	29.438
5133912	4	150	2.875	29.250	3.375	29.438
5134122	5	150	2.875	29.250	3.625	29.438
5134048	6	150	2.875	29.250	3.750	29.438

Dimensions are nominal

Rigid Nonmetallic Sch. 40 Elbows - Special Radius

Schedule 40 90° Elbow Special Radius - Bell End

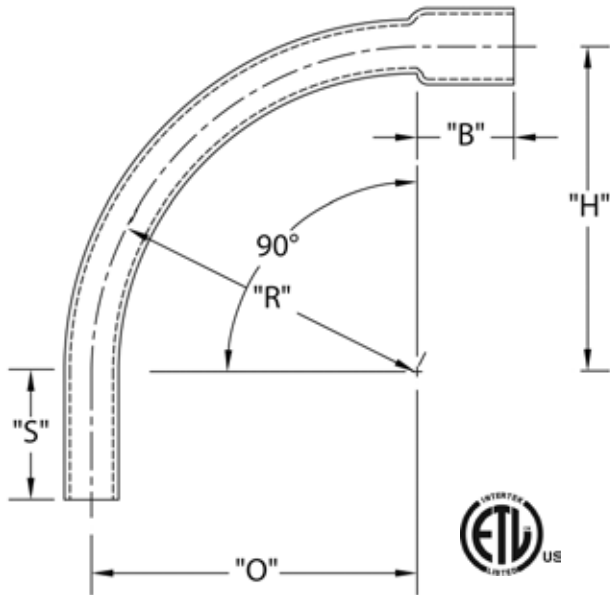

Schedule 40 90° Elbow 18" Radius Bell End

Part Number	Trade Size	"R"	"O"	"H"	"S" MIN	"B" MIN	"L"
5233844	1	18.000	18.000	18.000	1.875	1.500	28.250
5233923	1-1/4	18.000	18.000	18.000	2.000	1.500	28.250
5233839	1-1/2	18.000	18.000	18.000	2.000	2.000	28.250
5233846	2	18.000	18.000	18.000	2.000	2.000	28.250
5233856	2-1/2	18.000	18.000	18.000	3.000	2.250	28.250
5233850	3	18.000	18.000	18.000	3.125	2.500	28.250
5233985	4	18.000	18.000	18.000	3.375	3.250	28.250

Dimensions are nominal

Schedule 40 90° Elbow 24" Radius Bell End

Part Number	Trade Size	"R"	"O"	"H"	"S" MIN	"B" MIN	"L"
5234099	3/4	24.000	24.000	24.000	1.500	1.500	37.688
5233859	1	24.000	24.000	24.000	1.875	1.500	37.688
5233883	1-1/4	24.000	24.000	24.000	2.000	1.500	37.688
5233873	1-1/2	24.000	24.000	24.000	2.000	2.000	37.688
5133924	2	24.000	24.000	24.000	2.000	2.000	37.688
5233847	2-1/2	24.000	24.000	24.000	3.000	2.250	37.688
5233837	3	24.000	24.000	24.000	3.125	2.500	37.688
5233893	3-1/2	24.000	24.000	24.000	3.250	3.250	37.688
5233822	4	24.000	24.000	24.000	3.375	3.250	37.688

Dimensions are nominal

Schedule 40 90° Elbow 30" Radius Bell End

Part Number	Trade Size	"R"	"O"	"H"	"S" MIN	"B" MIN	"L"
5233920	2	30.000	30.000	30.000	2.000	2.000	47.125
5233981	2-1/2	30.000	30.000	30.000	3.000	2.250	47.125
5234081	3	30.000	30.000	30.000	3.125	2.500	47.125
5233852	4	30.000	30.000	30.000	3.375	3.250	47.125
5233872	5	30.000	30.000	30.000	3.625	4.250	47.125

Dimensions are nominal

Schedule 40 90° Elbow 36" Radius Bell End

Part Number	Trade Size	"R"	"O"	"H"	"S" MIN	"B" MIN	"L"
5233855	1	36.000	36.000	36.000	1.875	1.500	56.500
5233884	1-1/4	36.000	36.000	36.000	2.000	1.500	56.500
5233866	1-1/2	36.000	36.000	36.000	2.000	2.000	56.500
5233848	2	36.000	36.000	36.000	2.000	2.000	56.500
5233857	2-1/2	36.000	36.000	36.000	3.000	2.250	56.500
5233930	3	36.000	36.000	36.000	3.125	2.500	56.500
5233818	3-1/2	36.000	36.000	36.000	3.250	3.250	56.500
5233842	4	36.000	36.000	36.000	3.375	3.250	56.500
5233841	5	36.000	36.000	36.000	3.625	4.250	56.500
5233877	6	36.000	36.000	36.000	3.750	5.000	56.500

Dimensions are nominal

Schedule 40 90° Elbow 48" Radius Bell End

Part Number	Trade Size	"R"	"O"	"H"	"S" MIN	"B" MIN	"L"
5236338	1	48.000	48.000	48.000	1.875	1.500	75.375
5234053	1-1/4	48.000	48.000	48.000	2.000	1.500	75.375
5233865	1-1/2	48.000	48.000	48.000	2.000	2.000	75.375
5233876	2	48.000	48.000	48.000	2.000	2.000	75.375
5233849	2-1/2	48.000	48.000	48.000	3.000	2.250	75.375
5233817	3	48.000	48.000	48.000	3.125	2.500	75.375
5233892	3-1/2	48.000	48.000	48.000	3.250	3.250	75.375
5233843	4	48.000	48.000	48.000	3.375	3.250	75.375
5233868	5	48.000	48.000	48.000	3.625	4.250	75.375
5233816	6	48.000	48.000	48.000	3.750	5.000	75.375

Dimensions are nominal

Schedule 40 90° Elbow 60" Radius Bell End

Part Number	Trade Size	"R"	"O"	"H"	"S" MIN	"B" MIN	"L"
5233786	2	60.000	60.000	60.000	2.000	2.000	94.250
5233819	3	60.000	60.000	60.000	3.125	2.500	94.250
5233854	4	60.000	60.000	60.000	3.375	3.250	94.250
5233885	5	60.000	60.000	60.000	3.625	4.250	94.250
5233886	6	60.000	60.000	60.000	3.750	5.000	94.250

Dimensions are nominal

Rigid Nonmetallic Sch. 40 Elbows - Special Radius

Schedule 40 90° Elbow Special Radius - Bell End

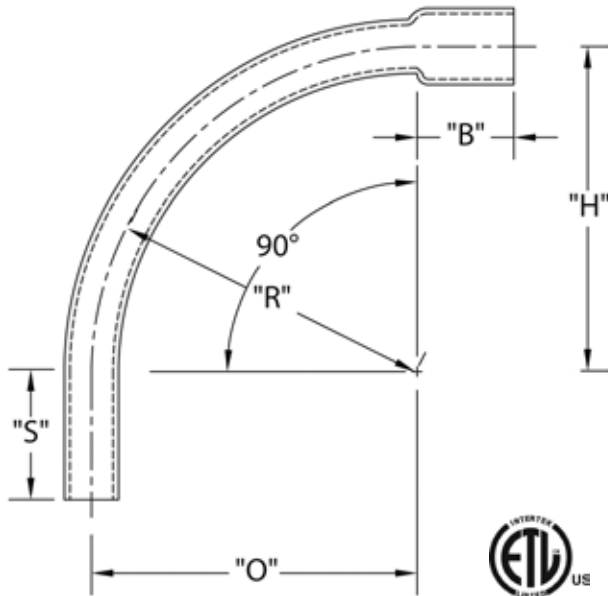

Schedule 40 90° Elbow 84" Radius Bell End

Part Number	Trade Size	"R"	"O"	"H"	"S" MIN	"B" MIN	"L"
5234026	6	84.000	84.000	84.000	3.750	5.000	132.000

Dimensions are nominal

Schedule 40 90° Elbow 96" Radius Bell End

Part Number	Trade Size	"R"	"O"	"H"	"S" MIN	"B" MIN	"L"
5234035	6	96.000	96.000	96.000	3.750	5.000	150.875

Dimensions are nominal

Schedule 40 90° Elbow 120" Radius Bell End

Part Number	Trade Size	"R"	"O"	"H"	"S" MIN	"B" MIN	"L"
5234116	2	120.000	120.000	120.000	2.000	2.000	188.500
5233927	4	120.000	120.000	120.000	3.375	3.250	188.500
5234007	6	120.000	120.000	120.000	3.750	5.000	188.500

Dimensions are nominal

Schedule 40 90° Elbow 72" Radius Bell End

Part Number	Trade Size	"R"	"O"	"H"	"S" MIN	"B" MIN	"L"
5234155	3	72.000	72.000	72.000	3.125	2.500	113.125
5233787	4	72.000	72.000	72.000	3.625	3.250	113.125
5233928	6	72.000	72.000	72.000	6.750	5.000	113.125

Dimensions are nominal

Schedule 40 90° Elbow 150" Radius Bell End

Part Number	Trade Size	"R"	"O"	"H"	"S" MIN	"B" MIN	"L"
5234156	3	150.000	150.000	150.000	3.125	2.500	235.625

Dimensions are nominal

Rigid Nonmetallic Sch. 40 Elbows - Special Radius

Schedule 40 45° Elbow Special Radius - Bell End

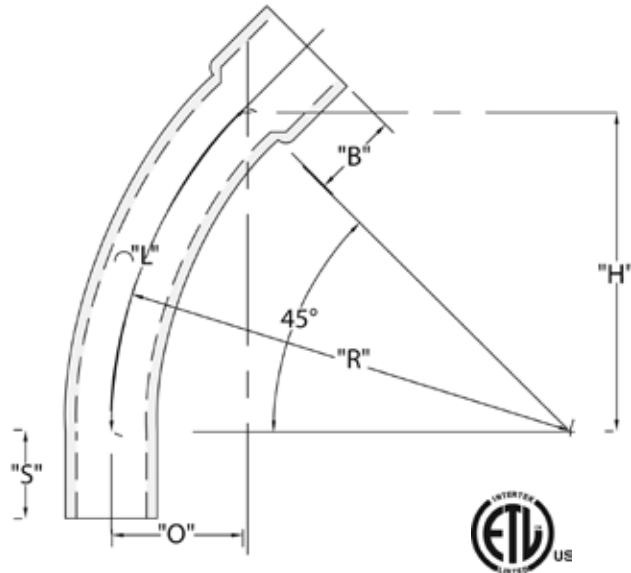

Schedule 40 45° Elbow 18" Radius Bell End

Part Number	Trade Size	"R"	"O"	"H"	"S" MIN	"B" MIN	"L"
5234008	1	18.000	5.250	12.750	1.875	1.500	14.125
5233797	2	18.000	5.250	12.750	2.000	2.000	14.125
5233973	2-1/2	18.000	5.250	12.750	3.000	2.250	14.125
5233799	3	18.000	5.250	12.750	3.125	2.500	14.125

Dimensions are nominal

Schedule 40 45° Elbow 24" Radius Bell End

Part Number	Trade Size	"R"	"O"	"H"	"S" MIN	"B" MIN	"L"
5233878	1	24.000	7.00	17.000	1.875	1.500	18.875
5233941	1-1/4	24.000	7.00	17.000	2.000	1.500	18.875
5233874	1-1/2	24.000	7.00	17.000	2.000	2.000	18.875
5233815	2	24.000	7.00	17.000	2.000	2.000	18.875
5233935	2-1/2	24.000	7.00	17.000	3.000	2.250	18.875
5233800	3	24.000	7.00	17.000	3.125	2.500	18.875
5233802	3-1/2	24.000	7.00	17.000	3.250	3.250	18.875
5233812	4	24.000	7.00	17.000	3.375	3.250	18.875

Dimensions are nominal

Schedule 40 45° Elbow 30" Radius Bell End

Part Number	Trade Size	"R"	"O"	"H"	"S" MIN	"B" MIN	"L"
5233953	4	30.000	8.750	21.250	3.375	3.250	23.563

Dimensions are nominal

Schedule 40 45° Elbow 36" Radius Bell End

Part Number	Trade Size	"R"	"O"	"H"	"S" MIN	"B" MIN	"L"
5233919	1	36.000	10.500	25.438	1.875	1.500	28.250
5234083	1-1/2	36.000	10.500	25.438	2.000	2.000	28.250
5233778	2	36.000	10.500	25.438	2.000	2.000	28.250
5233801	2-1/2	36.00	10.500	25.438	3.000	2.250	28.250
5233779	3	36.000	10.500	25.438	3.125	2.500	28.250
5233939	3-1/2	36.000	10.500	25.438	3.250	3.250	28.250
5233777	4	36.000	10.500	25.438	3.375	3.250	28.250
5233780	5	36.000	10.500	25.438	3.625	4.250	28.250
5133894	6	36.000	10.500	25.438	3.750	5.000	28.250

Dimensions are nominal

Schedule 40 45° Elbow 48" Radius Bell End

Part Number	Trade Size	"R"	"O"	"H"	"S" MIN	"B" MIN	"L"
5233811	1-1/2	48.000	14.000	33.313	2.000	2.000	37.688
5133759	2	48.000	14.000	33.313	2.000	2.000	37.688
5233785	2-1/2	48.000	14.000	33.313	3.000	2.250	37.688
5233782	3	48.000	14.000	33.313	3.125	2.500	37.688
5133761	4	48.000	14.000	33.313	3.375	3.250	37.688
5233781	5	48.000	14.000	33.313	3.625	3.250	37.688
5233813	6	48.000	14.000	33.313	3.750	4.250	37.688
5233989D	8	48.000	14.000	33.938	6.625	5.000	37.688

Dimensions are nominal

Schedule 40 45° Elbow 60" Radius Bell End

Part Number	Trade Size	"R"	"O"	"H"	"S" MIN	"B" MIN	"L"
5233808	2	60.000	17.563	42.375	2.000	2.000	47.125
5233946	4	60.000	17.563	42.375	3.375	3.250	47.125
5233947	5	60.000	17.563	42.375	3.625	4.250	47.125
5233806	6	60.000	17.563	42.375	3.750	5.000	47.125

Dimensions are nominal

Schedule 40 45° Elbow 150" Radius Bell End

Part Number	Trade Size	"R"	"O"	"H"	"S" MIN	"B" MIN	"L"
5234015	2	150.000	43.938	106.063	2.000	2.000	117.813
5233783	3	150.000	43.938	106.063	3.125	2.500	117.813
5233951	4	150.000	43.938	106.063	3.625	3.250	117.813
5233952	5	150.000	43.938	106.063	3.625	4.250	117.813
5233804	6	150.000	43.938	106.063	3.750	5.000	117.813

Dimensions are nominal

Rigid Nonmetallic Sch. 40 Elbows - Special Radius

Schedule 40 30° Elbow Special Radius - Bell End

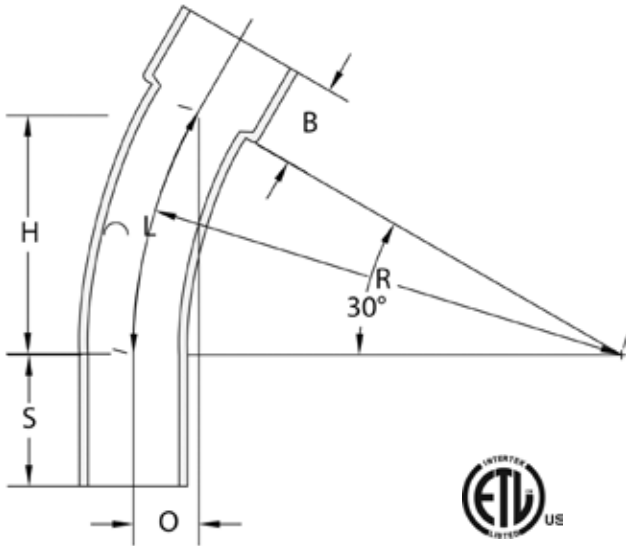

Schedule 40 30° Elbow 18" Radius Bell End

Part Number	Trade Size	"R"	"O"	"H"	"S" MIN	"B" MIN	"L"
5233789	2	18.000	2.438	9.063	2.000	2.000	9.438
5233969	3	18.000	2.438	9.063	3.125	2.500	9.438

Dimensions are nominal

Schedule 40 30° Elbow 24" Radius Bell End

Part Number	Trade Size	"R"	"O"	"H"	"S" MIN	"B" MIN	"L"
5236435	1	24.000	3.188	12.000	1.875	1.500	12.563
5233803	1-1/2	24.000	3.188	12.000	2.000	2.000	12.563
5233796	2	24.000	3.188	12.000	2.000	2.000	12.563
5233958	3	24.000	3.188	12.000	3.125	2.500	12.563
5236439	3-1/2	24.000	3.188	12.000	3.250	3.250	12.563
5233788	4	24.000	3.188	12.000	3.375	3.250	12.563

Dimensions are nominal

Schedule 40 30° Elbow 30" Radius Bell End

Part Number	Trade Size	"R"	"O"	"H"	"S" MIN	"B" MIN	"L"
5233898	4	30.000	4.000	15.000	3.375	3.250	15.938

Dimensions are nominal

Schedule 40 30° Elbow 36" Radius Bell End

Part Number	Trade Size	"R"	"O"	"H"	"S" MIN	"B" MIN	"L"
5233792	2	36.000	4.813	18.000	2.000	2.000	18.875
5233793	3	36.000	4.813	18.000	3.125	2.500	18.875
5233790	4	36.000	4.813	18.000	3.375	3.250	18.875
5233933	5	36.000	4.813	18.000	3.625	4.250	18.875
5233791	6	36.000	4.813	18.000	3.750	5.000	18.875

Dimensions are nominal

Schedule 40 30° Elbow 48" Radius Bell End

Part Number	Trade Size	"R"	"O"	"H"	"S" MIN	"B" MIN	"L"
5233820	2	48.000	6.438	24.000	2.000	2.000	25.125
5233809	3	48.000	6.438	24.000	3.125	2.500	25.125
5233838	4	48.000	6.438	24.000	3.375	3.250	25.125
5233959	5	48.000	6.438	24.000	3.625	4.250	25.125
5233861	6	48.000	6.438	24.000	3.750	5.000	25.125

Dimensions are nominal

Schedule 40 30° Elbow 60" Radius Bell End

Part Number	Trade Size	"R"	"O"	"H"	"S" MIN	"B" MIN	"L"
5233999	4	60.000	8.063	30.000	3.375	3.250	31.438

Dimensions are nominal

Schedule 40 30° Elbow 120" Radius Bell End

Part Number	Trade Size	"R"	"O"	"H"	"S" MIN	"B" MIN	"L"
5233962	4	120.000	16.063	60.000	3.375	3.250	62.813

Dimensions are nominal

Schedule 40 30° Elbow 150" Radius Bell End

Part Number	Trade Size	"R"	"O"	"H"	"S" MIN	"B" MIN	"L"
5234135	3	150.000	20.125	75.000	3.125	2.500	78.563
5233964	4	150.000	20.125	75.000	3.375	3.250	78.563

Dimensions are nominal

Rigid Nonmetallic Sch. 40 Elbows - Special Radius

Schedule 40 22-1/2° Elbow Special Radius - Bell End

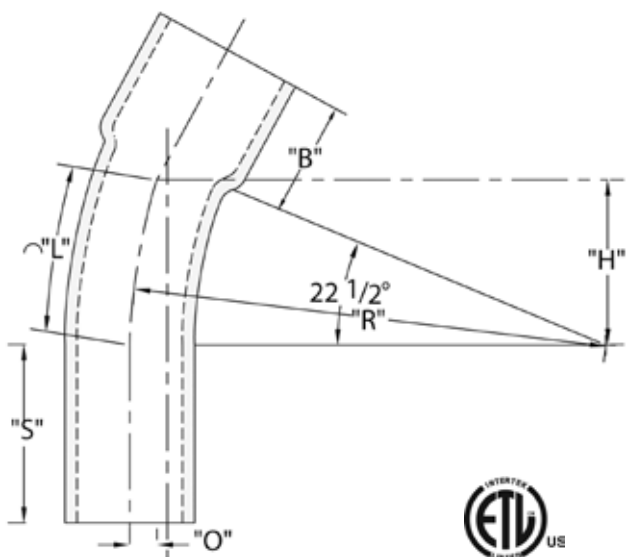

Schedule 40 22-1/2° Elbow 36" Radius Bell End

Part Number	Trade Size	"R"	"O"	"H"	"S" MIN	"B" MIN	"L"
5233997	1-1/2	36.000	2.750	13.750	2.000	2.000	14.125
5233851	2	36.000	2.750	13.750	2.000	2.000	14.125
5233937	2-1/2	36.000	2.750	13.750	3.000	2.250	14.125
5233904	3	36.000	2.750	13.750	3.125	2.500	14.125
5233853	4	36.000	2.750	13.750	3.375	3.250	14.125
5133888	5	36.000	2.750	13.750	3.625	4.250	14.125
5233905	6	36.000	2.750	13.750	3.750	5.000	14.125

Dimensions are nominal

Schedule 40 22-1/2° Elbow 48" Radius Bell End

Part Number	Trade Size	"R"	"O"	"H"	"S" MIN	"B" MIN	"L"
5233995	1-1/4	48.000	3.625	18.375	2.000	1.500	18.875
5233984	2	48.000	3.625	18.375	2.000	2.000	18.875
5233907	3	48.000	3.625	18.375	3.125	2.500	18.875
5233932	4	48.000	3.625	18.375	3.375	3.250	18.875
5233931	5	48.000	3.625	18.375	3.625	4.250	18.875
5233862	6	48.000	3.625	18.375	3.750	5.000	18.875

Dimensions are nominal

Schedule 40 22-1/2° Elbow 18" Radius Bell End

Part Number	Trade Size	"R"	"O"	"H"	"S" MIN	"B" MIN	"L"
5233902	1	18.000	1.375	6.875	1.875	1.500	7.063
5233908	1-1/2	18.000	1.375	6.875	2.000	2.000	7.063
5233639	2	18.000	1.375	6.875	2.000	2.000	7.063
5233936	2-1/2	18.000	1.375	6.875	3.000	2.250	7.063
5233845	3	18.000	1.375	6.875	3.125	2.500	7.063
5234016	4	18.000	1.375	6.875	3.375	3.250	7.063

Dimensions are nominal

Schedule 40 22-1/2° Elbow 24" Radius Bell End

Part Number	Trade Size	"R"	"O"	"H"	"S" MIN	"B" MIN	"L"
5236425	1-1/4	24.000	1.813	9.188	2.000	1.500	9.438
5233915	2	24.000	1.813	9.188	2.000	2.000	9.438
5234019	2-1/2	24.000	1.813	9.188	3.000	2.250	9.438
5233903	3	24.000	1.813	9.188	3.125	2.500	9.438
5233909	4	24.000	1.813	9.188	3.375	3.250	9.438
5233917	6	24.000	1.813	9.188	3.750	5.000	9.438

Dimensions are nominal

Schedule 40 22-1/2° Elbow 60" Radius Bell End

Part Number	Trade Size	"R"	"O"	"H"	"S" MIN	"B" MIN	"L"
5234013	2	60.000	4.563	23.000	2.000	2.000	23.563
5233899	3	60.000	4.563	23.000	3.125	2.500	23.563
5234012	4	60.000	4.563	23.000	3.375	3.250	23.563
5233961	5	60.000	4.563	23.000	3.625	4.250	23.563
5234065	6	60.000	4.563	23.000	3.750	5.000	23.563

Dimensions are nominal

Schedule 40 22-1/2° Elbow 30" Radius Bell End

Part Number	Trade Size	"R"	"O"	"H"	"S" MIN	"B" MIN	"L"
5233810	2	30.000	2.250	11.500	2.000	2.000	11.750
5233821	3	30.000	2.250	11.500	3.125	2.500	11.750
5233948	4	30.000	2.250	11.500	3.375	3.250	11.750
5233900	5	30.000	2.250	11.500	3.625	4.250	11.750

Dimensions are nominal

Schedule 40 22-1/2° Elbow 150" Radius Bell End

Part Number	Trade Size	"R"	"O"	"H"	"S" MIN	"B" MIN	"L"
5234014	2	150.000	11.375	57.375	2.000	2.000	58.875
5233887	3	150.000	11.375	57.375	3.125	2.500	58.875
5233870	4	150.000	11.375	57.375	3.375	3.250	58.875
5233960	5	150.000	11.375	57.375	3.625	4.250	58.875
5234055	6	150.000	11.375	57.375	3.750	5.000	58.875

Dimensions are nominal

Rigid Nonmetallic Sch. 40 Elbows - Special Radius

Schedule 40 11-1/4° Elbow Special Radius - Bell End

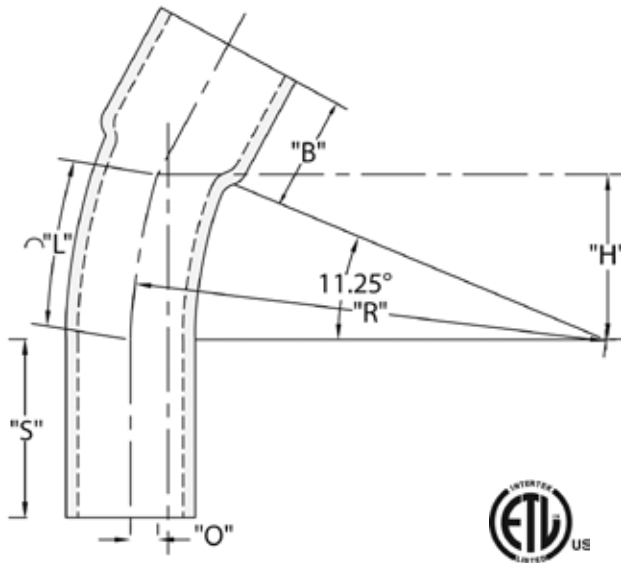

Schedule 40 11-1/4° Elbow 36" Radius Bell End

Part Number	Trade Size	"R"	"O"	"H"	"S" MIN	"B" MIN	"L"
5233963	2	36.000	.688	7.000	2.000	2.000	7.063
5234129	2-1/2	36.000	.688	7.000	3.000	2.250	7.063
5234082	3	36.000	.688	7.000	3.125	2.500	7.063
5233910	4	36.000	.688	7.000	3.375	3.250	7.063
5233914	5	36.000	.688	7.000	3.625	4.250	7.063
5233987	6	36.000	.688	7.000	3.750	5.000	7.063

Dimensions are nominal

Schedule 40 11-1/4° Elbow 48" Radius Bell End

Part Number	Trade Size	"R"	"O"	"H"	"S" MIN	"B" MIN	"L"
5233990	4	48.000	.938	9.375	3.375	3.250	9.438
5233977	5	48.000	.938	9.375	3.625	4.250	9.438
5134078	6	48.000	.938	9.375	3.750	5.000	9.438

Dimensions are nominal

Schedule 40 11-1/4° Elbow 24" Radius Bell End

Part Number	Trade Size	"R"	"O"	"H"	"S" MIN	"B" MIN	"L"
5233974	2	24.000	.469	4.688	2.000	2.000	4.719
5233991	4	24.000	.469	4.688	3.375	3.250	4.719
5233965	5	24.000	.469	4.688	3.625	4.250	4.719

Dimensions are nominal

Schedule 40 11-1/4° Elbow 120" Radius Bell End

Part Number	Trade Size	"R"	"O"	"H"	"S" MIN	"B" MIN	"L"
5234023	4	120.000	2.313	23.438	3.375	3.250	23.563

Dimensions are nominal

Schedule 40 11-1/4° Elbow 30" Radius Bell End

Part Number	Trade Size	"R"	"O"	"H"	"S" MIN	"B" MIN	"L"
5233988	6	30.000	.563	5.875	3.750	5.000	5.875

Dimensions are nominal

Schedule 40 11-1/4° Elbow 150" Radius Bell End

Part Number	Trade Size	"R"	"O"	"H"	"S" MIN	"B" MIN	"L"
5233911	2	150.000	2.875	29.250	2.000	2.000	29.438
5234047	3	150.000	2.875	29.250	3.125	2.500	29.438
5233912	4	150.000	2.875	29.250	3.375	3.250	29.438
5234122	5	150.000	2.875	29.250	3.625	4.250	29.438
5234048	6	150.000	2.875	29.250	3.750	5.000	29.438

Dimensions are nominal

Rigid Nonmetallic Sch. 80 Elbows - Standard Radius

Schedule 80 90° Elbow - Plain End

Part Number	Trade Size	Carton Qty.	"R"	"O"	"H"	"S" MIN	"L"
5121053	1/2	50	4.000	4.000	4.000	1.500	6.250
5121054	3/4	35	4.500	4.500	4.500	1.500	7.125
5121055	1	20	5.750	5.750	5.750	1.875	9.000
5121056	1-1/4	30	7.250	7.250	7.250	2.000	11.375
5121057	1-1/2	30	8.250	8.250	8.250	2.000	13.000
5121058	2	15	9.500	9.500	9.500	2.000	15.000
5121059	2-1/2	18	10.500	10.500	10.500	3.000	16.500
5121060	3	14	13.000	13.000	13.000	3.125	20.375
5121068	3-1/2	12	15.000	15.000	15.000	3.250	23.500
5121061	4	10	16.000	16.000	16.000	3.375	25.125
5121062	5	30*	24.000	24.000	24.000	3.625	37.625
5121063	6	25*	30.000	30.000	30.000	3.750	47.125

* Pallet Quantity

Dimensions are nominal

Conforms to UL651 and NEMA TC3

Material is Rigid PVC

Bend Tolerance is $\pm 2^\circ$

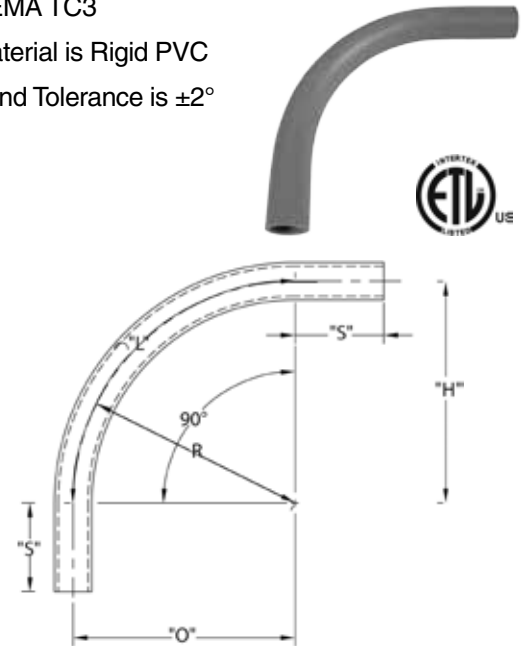

Schedule 80 45° Elbow - Plain End

Part Number	Trade Size	Carton Qty.	"R"	"O"	"H"	"S" MIN	"L"
5121003	1/2	50	4.000	1.188	2.875	1.500	3.125
5121004	3/4	25	4.500	1.313	3.188	1.500	3.500
5121005	1	20	5.750	1.688	4.000	1.875	4.500
5121006	1-1/4	25	7.250	2.125	5.125	2.000	5.688
5121007	1-1/2	20	8.250	2.375	5.875	2.000	6.500
5121008	2	10	9.500	2.813	6.750	2.000	7.500
5121009	2-1/2	20	10.500	2.563	7.375	3.000	8.250
5121010	3	8	13.000	3.813	9.188	3.125	10.250
5121011	4	20	16.000	4.688	11.438	3.375	12.625
5121012	5	30*	24.000	7.000	17.000	3.625	18.875
5121013	6	25*	30.000	8.813	21.250	3.750	23.875

* Pallet Quantity

Dimensions are nominal

Conforms to UL651 and NEMA TC3

Material is Rigid PVC

Bend Tolerance is $\pm 2^\circ$

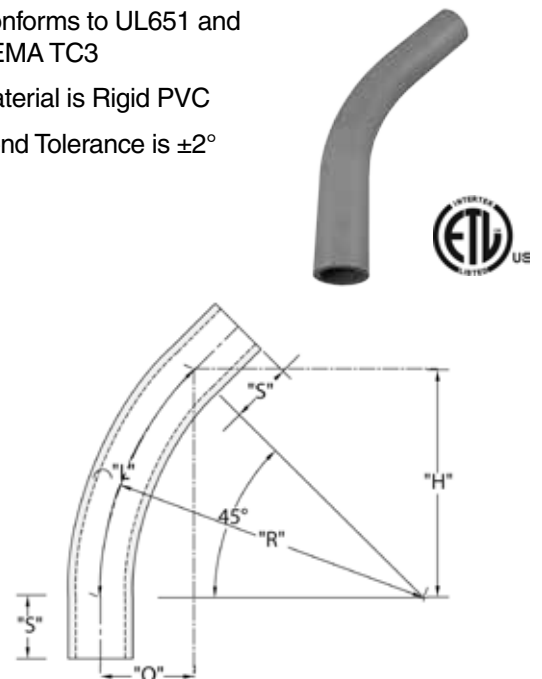

Rigid Nonmetallic Sch. 80 Elbows - Standard Radius

Schedule 80 30° Elbow - Plain End

Conforms to UL651 and NEMA TC3

Material is Rigid PVC

Bend Tolerance is $\pm 2^\circ$

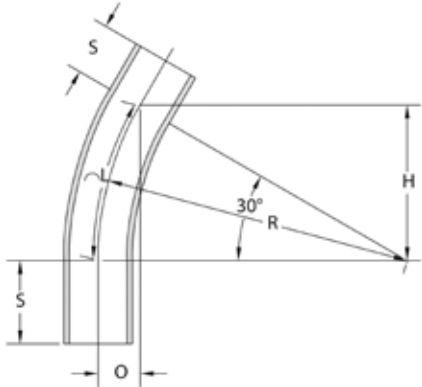

Part Number	Trade Size	Carton Qty.	"R"	"O"	"H"	"S" MIN	"L"
5121000	1/2	50	4.000	.500	2.000	1.500	2.125
5121001	3/4	25	4.500	.625	2.250	1.500	2.375
5121002	1	20	5.750	.750	2.875	1.875	3.000
5121106	1-1/4	25	7.250	1.000	3.625	2.000	3.813
5121850	1-1/2	20	8.250	1.063	4.125	2.000	4.313
5121108	2	10	9.500	1.250	4.750	2.000	5.000
5121109	2-1/2	20	10.500	1.438	5.250	3.000	5.500
5121110	3	8	13.000	1.750	6.500	3.125	6.813
5121111	4	20	16.000	2.063	8.000	3.375	8.375
5121112	5	30*	24.000	3.188	12.000	3.625	12.563
5121113	6	25*	30.000	4.000	15.000	3.750	15.688

* Pallet Quantity

Dimensions are nominal

Schedule 80 22-1/2° Elbow - Plain End

Conforms to UL651 and NEMA TC3

Material is Rigid PVC

Bend Tolerance is $\pm 2^\circ$

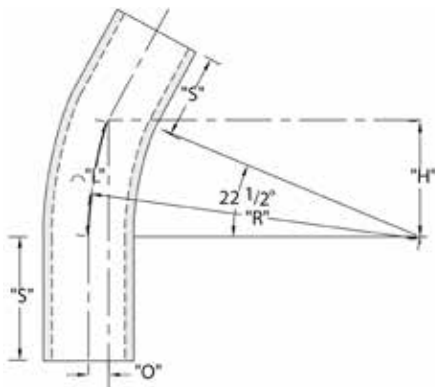

Part Number	Trade Size	Carton Qty.	"R"	"O"	"H"	"S" MIN	"L"
5136649	1-1/2	25	8.250	.625	3.125	2.000	3.250
5136659	2	10	9.500	.750	3.625	2.000	3.750
5136669	2-1/2	20	10.500	.813	4.000	3.000	4.125
5136679	3	8	13.000	1.000	5.000	3.125	5.125
5121868	4	20	16.000	1.250	6.125	3.375	6.250
5121125	5	*60	24.000	1.813	9.188	3.625	9.375

* Pallet Quantity

Dimensions are nominal

Rigid Nonmetallic Sch. 80 Elbows - Standard Radius

Schedule 80 90° Elbow - Bell End

Part Number	Trade Size	Carton Qty.	"R"	"O"	"H"	"S" MIN	"B" MIN	"L"
5221056	1-1/4	30	7.250	7.250	7.250	2.000	1.500	11.375
5221057	1-1/2	30	8.250	8.250	8.250	2.000	2.000	13.000
5221058	2	15	9.500	9.500	9.500	2.000	2.000	15.000
5221059	2-1/2	18	10.500	10.500	10.500	3.000	2.250	16.500
5221060	3	14	13.000	13.000	13.000	3.125	2.500	20.375
5221061	4	10	16.000	16.000	16.000	3.375	3.250	25.125
5221062	5	30*	24.000	24.000	24.000	3.625	4.250	37.625
5221117	6	25*	30.000	30.000	30.000	3.750	5.000	47.125

* Pallet Quantity

Dimensions are nominal

Conforms to UL651 and NEMA TC3

Material is Rigid PVC

Bend Tolerance is $\pm 2^\circ$

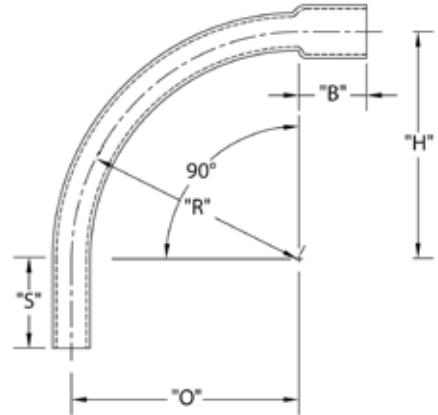

Schedule 80 45° Elbow - Bell End

Part Number	Trade Size	Carton Qty.	"R"	"O"	"H"	"S" MIN	"B" MIN	"L"
5221006	1-1/4	25	7.250	2.125	5.125	2.000	1.500	5.688
5221007	1-1/2	20	8.250	2.438	5.813	2.000	2.000	6.500
5221008	2	10	9.500	2.813	6.750	2.000	2.000	7.500
5221009	2-1/2	20	10.500	3.063	7.438	3.000	2.250	8.250
5221010	3	8	13.000	3.813	9.188	3.500	2.500	10.188
5221011	4	20	16.000	4.688	11.188	3.375	3.250	12.563
5221012	5	30*	24.000	7.000	17.000	3.625	4.250	18.875
5221013	6	25*	30.000	8.875	21.250	3.750	5.000	23.563

* Pallet Quantity

Dimensions are nominal

Conforms to UL651 and NEMA TC3

Material is Rigid PVC

Bend Tolerance is $\pm 2^\circ$

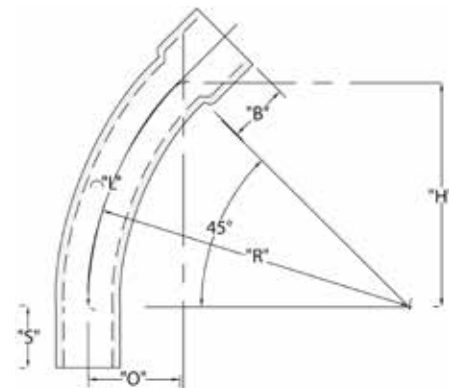

Rigid Nonmetallic Sch. 80 Elbows - Standard Radius

Schedule 80 22-1/2° Elbow - Bell End

Conforms to UL651 and NEMA TC3

Material is Rigid PVC

Bend Tolerance is $\pm 2^\circ$



Part Number	Trade Size	Carton Qty.	"R"	"O"	"H"	"S" MIN	"B" MIN	"L"
5221052	2	10	9.500	.750	3.625	2.000	2.000	3.750
5236679	3	8	13.000	1.000	5.000	3.125	2.500	5.125
5221868	4	10	16.000	1.250	6.125	3.375	3.250	6.250
5221116	6	*25	30.000	2.250	11.500	3.750	5.000	11.750

* Pallet Quantity

Dimensions are nominal

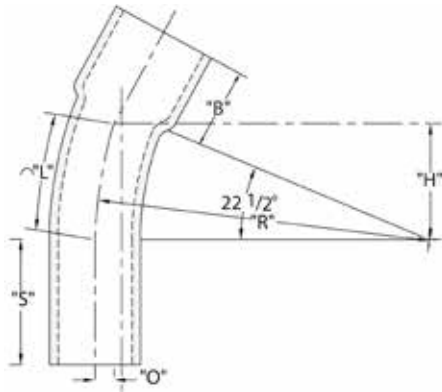

Rigid Nonmetallic Sch. 80 Elbows - Special Radius

Schedule 80 90° Elbow Special Radius - Plain End

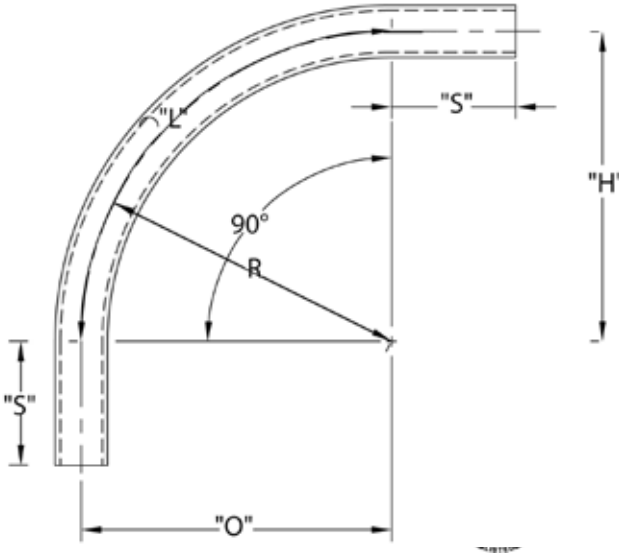

Schedule 80 90° Elbow 18" Radius Plain End

Part Number	Trade Size	"R"	"O"	"H"	"S" MIN	"L"
5121846	1	18	18	18	1.875	28.250
5119822	1-1/4	18	18	18	2.000	28.250
5121848	1-1/2	18	18	18	2.000	28.250
5121099	2	18	18	18	2.000	28.250
5121027	2-1/2	18	18	18	3.000	28.250
5121079	3	18	18	18	3.125	28.250

Dimensions are nominal

Schedule 80 90° Elbow 24" Radius Plain End

Part Number	Trade Size	"R"	"O"	"H"	"S" MIN	"L"
5121018	1	24	24	24	1.875	37.750
5119824	1-1/4	24	24	24	2.000	37.750
5121015	1-1/2	24	24	24	2.000	37.750
5121019	2	24	24	24	2.000	37.750
5121028	2-1/2	24	24	24	3.000	37.750
5121020	3	24	24	24	3.125	37.750
5121022	4	24	24	24	3.375	37.750

Dimensions are nominal

Schedule 80 90° Elbow 30" Radius Plain End

Part Number	Trade Size	"R"	"O"	"H"	"S" MIN	"L"
5121071	2	30	30	30	2.000	47.125
5121052	2-1/2	30	30	30	3.000	47.125
5136570	3	30	30	30	3.125	47.125
5136580	4	30	30	30	3.375	47.125

Dimensions are nominal

Schedule 80 90° Elbow 36" Radius Plain End

Part Number	Trade Size	"R"	"O"	"H"	"S" MIN	"L"
5121080	1	36	36	36	1.875	56.500
5121084	1-1/4	36	36	36	2.000	56.500
5121100	1-1/2	36	36	36	2.000	56.500
5121021	2	36	36	36	2.000	56.500
5121016	2-1/2	36	36	36	3.000	56.500
5121081	3	36	36	36	3.125	56.500
5121023	4	36	36	36	3.375	56.500
5121083	5	36	36	36	3.625	56.500
5121073	6	36	36	36	3.750	56.5

Dimensions are nominal

Schedule 80 90° Elbow 48" Radius Plain End

Part Number	Trade Size	"R"	"O"	"H"	"S" MIN	"L"
5121065	1	48	48	48	1.875	75.375
5121076	1-1/2	48	48	48	2.000	75.375
5121075	2	48	48	48	2.000	75.375
5121030	2-1/2	48	48	48	3.000	75.375
5121082	3	48	48	48	3.125	75.375
5121024	4	48	48	48	3.375	75.375
5121025	5	48	48	48	3.625	75.375
5121026	6	48	48	48	3.750	75.375

Dimensions are nominal

Schedule 80 90° Elbow 60" Radius Plain End

Part Number	Trade Size	"R"	"O"	"H"	"S" MIN	"L"
5121102	1-1/2	60	60	60	2.000	94.250
5121086	2	60	60	60	2.000	94.250
5136970	3	60	60	60	3.125	94.250
5121085	4	60	60	60	3.375	94.250
5121017	5	60	60	60	3.625	94.250
5121087	6	60	60	60	3.750	94.250

Dimensions are nominal

Schedule 80 90° Elbow 72" Radius Plain End

Part Number	Trade Size	"R"	"O"	"H"	"S" MIN	"L"
5121070	3	72	72	72	3.125	113.125
5136971	6	72	72	72	3.750	113.125

Dimensions are nominal

Schedule 80 90° Elbow 120" Radius Plain End

Part Number	Trade Size	"R"	"O"	"H"	"S" MIN	"L"
5133927	4	120	120	120	3.375	188.500

Dimensions are nominal

Rigid Nonmetallic Sch. 80 Elbows - Special Radius

Schedule 80 45° Elbow Special Radius - Plain End

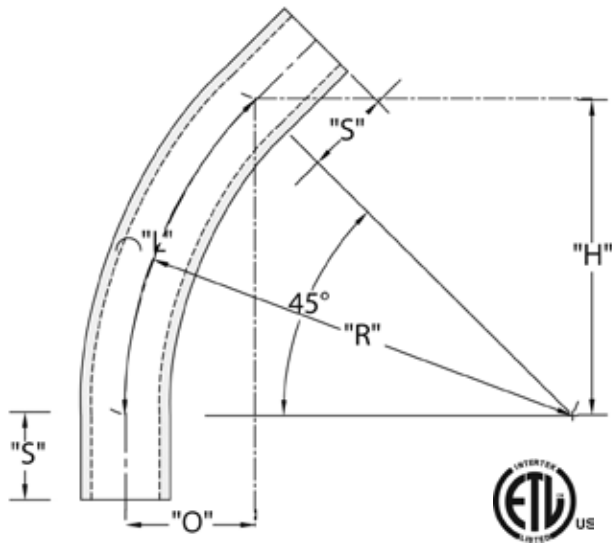

Schedule 80 45° Elbow 36" Radius Plain End

Part Number	Trade Size	"R"	"O"	"H"	"S" MIN	"L"
5136502	1	36.000	10.500	25.500	1.875	28.250
5136514	1-1/4	36.000	10.500	25.500	2.000	28.250
5136533	1-1/2	36.000	10.500	25.500	2.000	28.250
5121098	2	36.000	10.500	25.500	2.000	28.250
5121150	2-1/2	36.000	10.500	25.500	3.000	28.250
5121077	3	36.000	10.500	25.500	3.125	28.250
5119821	4	36.000	10.500	25.500	3.375	28.250
5119820	5	36.000	10.500	25.500	3.625	28.250
5121072	6	36.000	10.500	25.500	3.750	28.250

Dimensions are nominal

Schedule 80 45° Elbow 18" Radius Plain End

Part Number	Trade Size	"R"	"O"	"H"	"S" MIN	"L"
5121971	1	18.000	5.250	12.75	1.875	14.125
5136511	1-1/4	18.000	5.250	12.75	2.000	14.125
5121037	1-1/2	18.000	5.250	12.75	2.000	14.125
5136551	2	18.000	5.250	12.75	2.000	14.125
5136561	2-1/2	18.000	5.250	12.75	3.000	14.125

Dimensions are nominal

Schedule 80 45° Elbow 48" Radius Plain End

Part Number	Trade Size	"R"	"O"	"H"	"S" MIN	"L"
5136515	1-1/4	48.000	14.000	34.000	2.000	37.688
5121093	2	48.000	14.000	34.000	2.000	37.688
5121078	3	48.000	14.000	34.000	3.125	37.688
5121091	4	48.000	14.000	34.000	3.375	37.688
5121948	5	48.000	14.000	34.000	3.625	37.688
5119830	6	48.000	14.000	34.000	3.750	37.688

Dimensions are nominal

Schedule 80 45° Elbow 24" Radius Plain End

Part Number	Trade Size	"R"	"O"	"H"	"S" MIN	"L"
5136500	1	24.000	17.000	7.000	1.875	18.875
5136512	1-1/4	24.000	17.000	7.000	2.000	18.875
5163533	1-1/2	24.000	17.000	7.000	2.000	18.875
5121101	2	24.000	17.000	7.000	2.000	18.875
5121943	2-1/2	24.000	17.000	7.000	3.000	18.875
5121014	3	24.000	17.000	7.000	3.125	18.875
5121089	4	24.000	17.000	7.000	3.375	18.875

Dimensions are nominal

Schedule 80 45° Elbow 60" Radius Plain End

Part Number	Trade Size	"R"	"O"	"H"	"S" MIN	"L"
5136840	1-1/2	60.000	17.625	34.000	2.000	47.125
5136850	2	60.000	17.625	34.000	2.000	47.125
5136860	2-1/2	60.000	17.625	34.000	3.000	47.125
5136810	3	60.000	17.625	34.000	3.125	47.125
5121122	4	60.000	17.625	34.000	3.375	47.125

Dimensions are nominal

Rigid Nonmetallic Sch. 80 Elbows - Special Radius

Schedule 80 30° Elbow Special Radius - Plain End

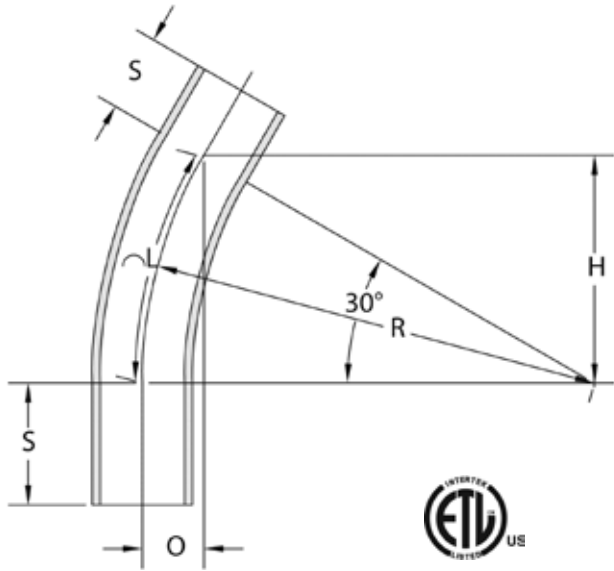

Schedule 80 30° Elbow 24" Radius Plain End

Part Number	Trade Size	"R"	"O"	"H"	"S" MIN	"L"
5136505	1	24.000	3.188	12.000	1.875	12.563
5136536	1-1/2	24.000	3.188	12.000	2.000	12.563
5136554	2	24.000	3.188	12.000	2.000	12.563
5136573	3	24.000	3.188	12.000	3.125	12.563
5136582	4	24.000	3.188	12.000	3.375	12.563

Dimensions are nominal

Schedule 80 30° Elbow 36" Radius Plain End

Part Number	Trade Size	"R"	"O"	"H"	"S" MIN	"L"
5136538	1-1/2	36.000	4.813	18.000	2.000	18.875
5121094	2	36.000	4.813	18.000	2.000	18.875
5136566	2-1/2	36.000	4.813	18.000	3.000	18.875
5136575	3	36.000	4.813	18.000	3.125	18.875
5121114	4	36.000	4.813	18.000	3.375	18.875
5136587	5	36.000	4.813	18.000	3.625	18.875
5136595	6	36.000	4.813	18.000	3.750	18.875

Dimensions are nominal

Schedule 80 30° Elbow 48" Radius Plain End

Part Number	Trade Size	"R"	"O"	"H"	"S" MIN	"L"
5121123	4	48.000	6.438	24.000	3.375	25.125
5121115	5	48.000	6.438	24.000	3.625	25.125
5136596	6	48.000	6.438	24.000	3.750	25.125

Dimensions are nominal

Schedule 80 30° Elbow 18" Radius Plain End

Part Number	Trade Size	"R"	"O"	"H"	"S" MIN	"L"
5136504	1	18.000	2.438	9.063	1.875	9.438
5136516	1-1/4	18.000	2.438	9.063	2.000	9.438
5136535	1-1/2	18.000	2.438	9.063	2.000	9.438
5136553	2	18.000	2.438	9.063	2.000	9.438
5136566	2-1/2	18.000	2.438	9.063	3.000	9.438
5136572	3	18.000	2.438	9.063	3.125	9.438

Dimensions are nominal

Schedule 80 30° Elbow 60" Radius Plain End

Part Number	Trade Size	"R"	"O"	"H"	"S" MIN	"L"
5136750	2	60	8.063	30.000	2.000	31.438

Dimensions are nominal

Rigid Nonmetallic Sch. 80 Elbows - Special Radius

Schedule 80 90° Elbow Special Radius - Bell End

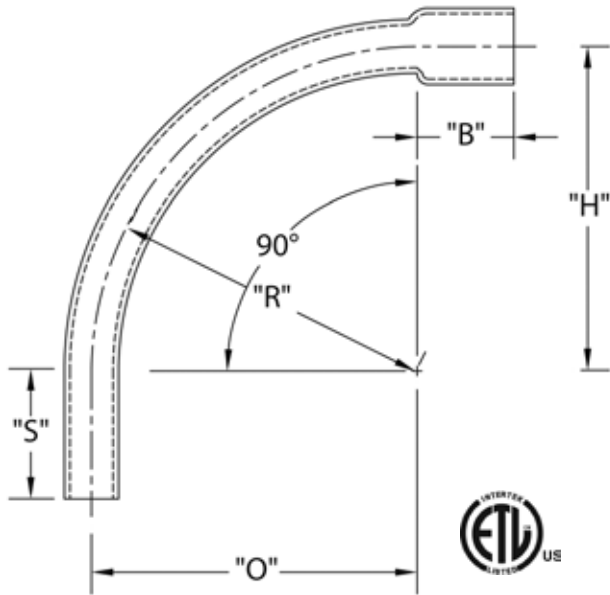

Schedule 80 90° Elbow 18" Radius Bell End

Part Number	Trade Size	"R"	"O"	"H"	"S" MIN	"B" MIN	"L"
5221846	1	18.000	18.000	18.000	1.875	1.500	28.250
5221079	3	18.000	18.000	18.000	3.125	2.500	28.250

Dimensions are nominal

Schedule 80 90° Elbow 36" Radius Bell End

Part Number	Trade Size	"R"	"O"	"H"	"S" MIN	"B" MIN	"L"
5221080	1	36.000	36.000	36.000	1.875	1.500	56.500
5121049	1-1/2	36.000	36.000	36.000	2.000	2.000	56.500
5121047	2	36.000	36.000	36.000	2.000	2.000	56.500
5221100	2-1/2	36.000	36.000	36.000	3.000	2.250	56.500
5121038	3	36.000	36.000	36.000	3.125	2.500	56.500
5221023	4	36.000	36.000	36.000	3.375	3.250	56.500
5221083	5	36.000	36.000	36.000	3.625	4.250	56.500
5121045	6	36.000	36.000	36.000	3.750	5.000	56.500

Dimensions are nominal

Schedule 80 90° Elbow 48" Radius Bell End

Part Number	Trade Size	"R"	"O"	"H"	"S" MIN	"B" MIN	"L"
5221065	1	48.000	48.000	48.000	1.875	1.500	75.375
5236510	1-1/4	48.000	48.000	48.000	2.000	1.500	75.375
5221075	2	48.000	48.000	48.000	2.000	2.000	75.375
5221030	2-1/2	48.000	48.000	48.000	3.000	2.250	75.375
5221082	3	48.000	48.000	48.000	3.125	2.500	75.375
5221024	4	48.000	48.000	48.000	3.375	3.250	75.375
5221025	5	48.000	48.000	48.000	3.625	4.250	75.375
5121033	6	48.000	48.000	48.000	3.750	5.000	75.375

Dimensions are nominal

Schedule 80 90° Elbow 60" Radius Bell End

Part Number	Trade Size	"R"	"O"	"H"	"S" MIN	"B" MIN	"L"
5221085	4	60.000	60.000	60.000	3.375	3.250	94.250
5233885	5	60.000	60.000	60.000	3.625	4.250	94.250
5121044	6	60.000	60.000	60.000	3.750	5.000	94.250

Dimensions are nominal

Schedule 80 90° Elbow 96" Radius Bell End

Part Number	Trade Size	"R"	"O"	"H"	"S" MIN	"B" MIN	"L"
5136973	6	96.000	96.000	96.000	3.750	5.000	150.875

Dimensions are nominal

Schedule 80 90° Elbow 120" Radius Bell End

Part Number	Trade Size	"R"	"O"	"H"	"S" MIN	"B" MIN	"L"
5221120	4	120.00	120.00	120.00	3.375	3.250	188.500

Dimensions are nominal

Schedule 80 90° Elbow 150" Radius Bell End

Part Number	Trade Size	"R"	"O"	"H"	"S" MIN	"B" MIN	"L"
5221121	4	150.000	150.000	150.000	3.375	3.325	235.625

Dimensions are nominal

Schedule 80 90° Elbow 24" Radius Bell End

Part Number	Trade Size	"R"	"O"	"H"	"S" MIN	"B" MIN	"L"
5221018	1	24.000	24.000	24.000	1.875	1.500	37.688
5219824	1-1/4	24.000	24.000	24.000	2.000	1.500	37.688
5221015	1-1/2	24.000	24.000	24.000	2.000	2.000	37.688
5121036	2	24.000	24.000	24.000	2.000	2.000	37.688
5122028	2-1/2	24.000	24.000	24.000	3.000	2.250	37.688
5121031	3	24.000	24.000	24.000	3.125	2.500	37.688
5221022	4	24.000	24.000	24.000	3.375	3.250	37.688

Dimensions are nominal

Schedule 80 90° Elbow 30" Radius Bell End

Part Number	Trade Size	"R"	"O"	"H"	"S" MIN	"B" MIN	"L"
5221071	2	30.000	30.000	30.000	2.000	2.000	47.125
5221053	2-1/2	30.000	30.000	30.000	3.000	2.250	47.125

Dimensions are nominal

Rigid Nonmetallic Sch. 80 Elbows - Special Radius

Schedule 80 45° Elbow Special Radius - Bell End

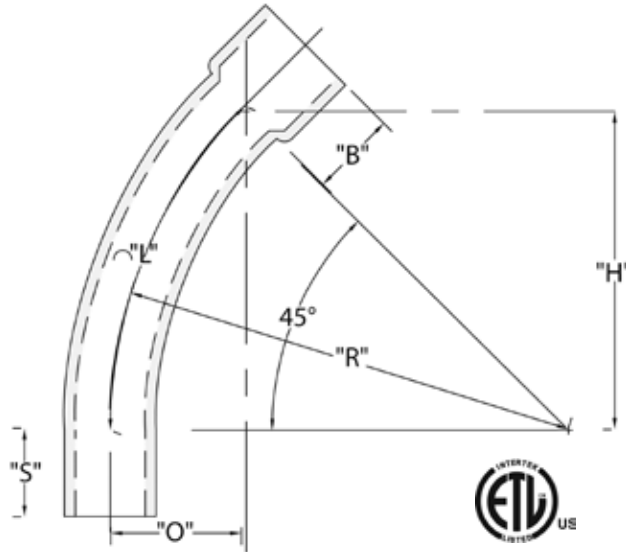

Schedule 80 45° Elbow 36" Radius Bell End

Part Number	Trade Size	"R"	"O"	"H"	"S" MIN	"B" MIN	"L"
5221098	2	36.000	10.500	25.438	2.000	2.000	28.250
5221150	2-1/2	36.000	10.500	25.438	3.000	2.250	28.250
5221077	3	36.000	10.500	25.438	3.125	2.500	28.250
5219821	4	36.000	10.500	25.438	3.375	3.250	28.250

Dimensions are nominal

Schedule 80 45° Elbow 48" Radius Bell End

Part Number	Trade Size	"R"	"O"	"H"	"S" MIN	"B" MIN	"L"
5221078	3	48.000	14.000	33.938	3.125	2.500	37.688
5221091	4	48.000	14.000	33.938	3.375	3.250	37.688
5221948	5	48.000	14.000	33.938	3.625	4.250	37.688
5219830	6	48.000	14.000	33.938	3.750	5.000	37.688

Dimensions are nominal

Schedule 80 45° Elbow 60" Radius Bell End

Part Number	Trade Size	"R"	"O"	"H"	"S" MIN	"B" MIN	"L"
5121949	5	60.000	17.563	42.375	3.625	4.250	47.125

Dimensions are nominal

Schedule 80 45° Elbow 24" Radius Bell End

Part Number	Trade Size	"R"	"O"	"H"	"S" MIN	"B" MIN	"L"
5221104	1	24.000	7.000	17.000	1.875	1.500	18.875
5221101	2	24.000	7.000	17.000	2.000	2.000	18.875
5122943	2-1/2	24.000	7.000	17.000	3.000	2.250	18.875
5221014	3	24.000	7.000	17.000	3.125	2.500	18.875
5221089	4	24.000	7.000	17.000	3.375	3.250	18.875

Dimensions are nominal

Schedule 80 45° Elbow 150" Radius Bell End

Part Number	Trade Size	"R"	"O"	"H"	"S" MIN	"B" MIN	"L"
5221090	3	150.000	43.938	106.063	3.125	2.500	117.813
5121043	4	150.000	43.938	106.063	3.375	3.250	117.813
5121097	5	150.000	43.938	106.063	3.625	4.250	117.813
5136972	6	150.000	43.938	106.063	3.750	5.000	117.813

Dimensions are nominal

PVC Nonmetallic Conduit Bodies & Junction Boxes



Rigid Nonmetallic PVC Conduit Bodies

Conduit Bodies - Type LB



1/2" THROUGH 2"



2-1/2" THROUGH 4"

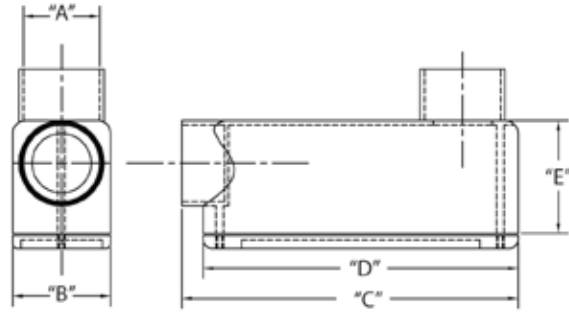

Part Number	Trade Size	Carton Quantity	"A"	"B"	"C"	"D"	"E"	Volume Cu. In.	3-Wire Fill
5133663	1/2	25	.875	1.313	4.188	4.000	1.438	4.3	#6 or smaller
5133664	3/4	15	1.063	1.500	4.938	4.625	1.625	6.5	#6 or smaller
5133665	1	10	1.313	1.750	5.875	5.375	2.000	11.8	#6 or smaller
5133666	1-1/4	10	1.688	2.500	7.563	7.188	2.375	25.0	XHHW #1
5133667	1-1/2	10	1.875	2.625	8.563	8.000	2.750	36.5	XHHW #2/0
5133668	2	5	2.375	3.125	9.813	9.563	3.375	63.5	XHHW #4/0
5133669	2-1/2	5	2.875	4.625	15.000	12.875	4.563	198.0	XHHW 500 MCM
5133670	3	5	3.643	4.625	15.125	12.875	4.563	198.0	XHHW 500 MCM
5133671	3-1/2	4	4.000	5.625	16.188	12.875	5.500	305.0	XHHW 500 MCM
5133672	4	4	4.000	5.625	16.188	12.875	5.500	305.0	XHHW 500 MCM

Dimensions are nominal

Conduit Bodies - Type LL



1/2" THROUGH 2"



2-1/2" THROUGH 4"

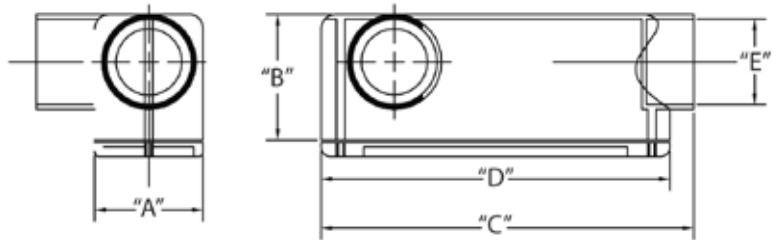

Part Number	Trade Size	Carton Quantity	"A"	"B"	"C"	"D"	"E"	Volume Cu. In.	3-Wire Fill
5133660	1/2	25	1.313	1.438	4.250	4.000	.875	4.3	#6 or smaller
5133661	3/4	15	1.500	1.625	4.938	4.625	1.063	6.5	#6 or smaller
5133662	1	10	1.750	2.000	6.000	5.375	1.313	11.8	#6 or smaller
5133649	1-1/4	10	2.438	2.438	7.625	7.188	1.625	25.0	XHHW #1
5133648	1-1/2	10	2.625	2.813	8.563	8.000	1.938	36.5	XHHW #2/0
5133647	2	5	3.063	3.438	9.875	9.500	2.375	63.5	XHHW #4/0
5133644	2-1/2	5	4.625	4.625	14.938	12.750	2.875	198.0	XHHW 500 MCM
5133646	3	5	4.625	4.625	15.000	12.813	3.500	198.0	XHHW 500 MCM
5133640	3-1/2	4	5.625	5.500	16.188	12.813	4.000	305.0	XHHW 500 MCM
5133645	4	4	5.625	5.500	15.938	12.813	4.500	305.0	XHHW 500 MCM

Dimensions are nominal

Rigid Nonmetallic PVC Conduit Bodies

Conduit Bodies - Type LR



1/2" THROUGH 2"

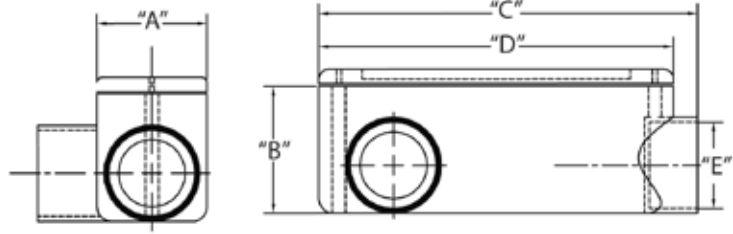

2-1/2" THROUGH 4"

Part Number	Trade Size	Carton Quantity	"A"	"B"	"C"	"D"	"E"	Volume Cu. In.	3-Wire Fill
5133650	1/2	25	1.313	1.438	4.250	4.000	.875	4.3	#6 or smaller
5133651	3/4	15	1.500	1.625	4.938	4.625	1.063	6.5	#6 or smaller
5133652	1	10	1.750	2.000	6.000	5.375	1.313	11.8	#6 or smaller
5133653	1-1/4	10	2.438	2.438	7.625	7.188	1.625	25.0	XHHW #1
5133654	1-1/2	10	2.625	2.813	8.563	8.000	1.938	36.5	XHHW #2/0
5133655	2	5	3.063	3.438	9.875	9.500	2.375	63.5	XHHW #4/0
5133658	2-1/2	5	4.625	4.625	14.938	12.750	2.875	198.0	XHHW 500 MCM
5133656	3	5	4.625	4.625	15.000	12.813	3.500	198.0	XHHW 500 MCM
5133659	3-1/2	4	5.625	5.500	16.188	12.813	4.000	305.0	XHHW 500 MCM
5133657	4	4	5.625	5.500	15.938	12.813	4.500	305.0	XHHW 500 MCM

Dimensions are nominal

Conduit Bodies - Type T



1/2" THROUGH 2"

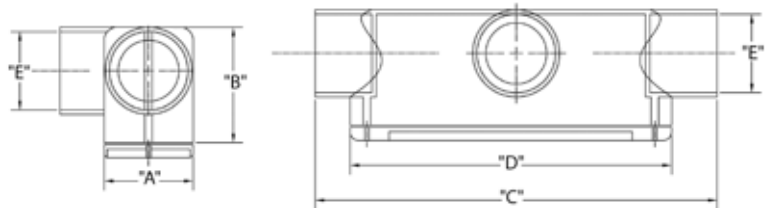

2-1/2" THROUGH 4"

Part Number	Trade Size	Carton Quantity	"A"	"B"	"C"	"D"	"E"	Volume Cu. In.	3-Wire Fill
5133563	1/2	25	1.938	1.500	4.625	4.000	.875	4.3	#6 or smaller
5133564	3/4	15	1.500	1.688	5.375	4.625	1.063	6.5	#6 or smaller
5133565	1	10	1.750	2.000	6.563	5.375	1.313	11.8	#6 or smaller
5133566	1-1/4	10	2.500	2.500	8.188	7.188	1.688	25.0	XHHW #1
5133567	1-1/2	10	2.625	2.813	9.250	8.000	1.938	36.5	XHHW #2/0
5133568	2	5	3.125	3.375	10.375	9.500	2.375	63.5	XHHW #4/0
5133569	2-1/2	2	4.625	4.625	19.000	12.875	3.500	198.0	XHHW 500 MCM
5133570	3	2	4.625	4.625	19.000	12.875	3.500	198.0	XHHW 500 MCM
5133572	3-1/2	1	5.563	5.563	20.375	13.750	4.000	305.0	XHHW 500 MCM
5133571	4	1	5.563	5.563	20.375	13.875	4.500	305.0	XHHW 500 MCM

Dimensions are nominal

Rigid Nonmetallic PVC Conduit Bodies

Conduit Bodies - Type C



1/2" THROUGH 2"



2-1/2" THROUGH 4"

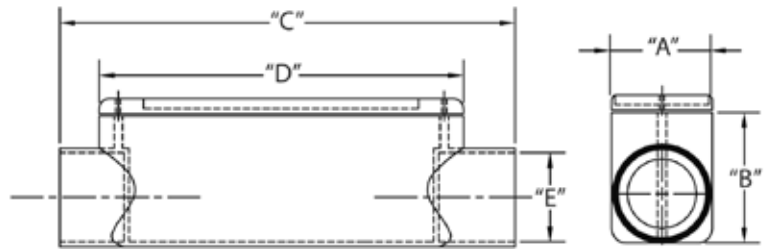

Part Number	Trade Size	Carton Quantity	"A"	"B"	"C"	"D"	"E"	Volume Cu. In.	3-Wire Fill
5133101	1/2	25	1.938	1.500	4.625	4.000	.875	4.3	#6 or smaller
5133102	3/4	15	1.500	1.688	5.375	4.625	1.063	6.5	#6 or smaller
5133103	1	10	1.750	2.000	6.563	5.375	1.313	11.8	#6 or smaller
5133104	1-1/4	10	2.500	2.500	8.188	7.188	1.688	25.0	XHHW #1
5133105	1-1/2	10	2.625	2.813	9.250	8.000	1.938	36.5	XHHW #2/0
5133106	2	5	3.125	3.375	10.375	9.500	2.375	63.5	XHHW #4/0
5133108	2-1/2	5	4.625	4.625	19.000	12.875	2.875	198.0	XHHW 500 MCM
5133107	3	5	4.625	4.625	19.000	12.875	3.500	198.0	XHHW 500 MCM
5133110	3-1/2	4	5.563	5.563	20.375	13.750	4.000	305.0	XHHW 500 MCM
5133109	4	4	4.000	5.563	20.188	13.875	4.500	305.0	XHHW 500 MCM

Dimensions are nominal

Conduit Bodies - Type E



1/2" THROUGH 2"



2-1/2" THROUGH 4"

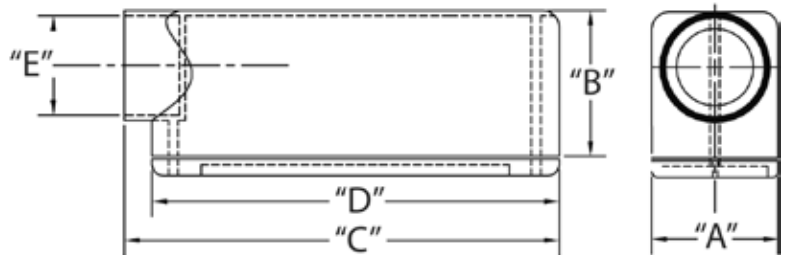

Part Number	Trade Size	Carton Quantity	"A"	"B"	"C"	"D"	"E"	Volume Cu. In.	3-Wire Fill
5133151	1/2	25	1.313	1.438	4.250	4.000	.875	4.3	#6 or smaller
5133152	3/4	15	1.500	1.625	4.938	4.625	1.063	6.5	#6 or smaller
5133153	1	10	1.750	2.000	6.000	5.375	1.313	11.8	#6 or smaller
5133154	1-1/4	10	2.438	2.438	7.625	7.188	1.625	25.0	XHHW #1
5133155	1-1/2	10	2.625	2.813	8.563	8.000	1.938	36.5	XHHW #2/0
5133156	2	5	3.063	3.438	9.875	9.500	2.375	63.5	XHHW #4/0
5133157	2-1/2	5	4.625	4.625	14.938	12.750	2.875	198.0	XHHW 500 MCM
5133158	3	5	4.625	4.625	15.000	12.813	3.500	198.0	XHHW 500 MCM
5133160	3-1/2	4	5.625	5.500	16.188	12.813	4.000	305.0	XHHW 500 MCM
5133159	4	4	5.625	5.500	15.938	12.813	4.500	305.0	XHHW 500 MCM

Dimensions are nominal

Nonmetallic PVC Junction Boxes

Round Junction Box



Part Number	Trade Size	Carton Quantity	"A"	"B"	"C"	"D"
5133690	1/2 & 3/4	15	4.750	4.063	1.875	1.063

Dimensions are nominal

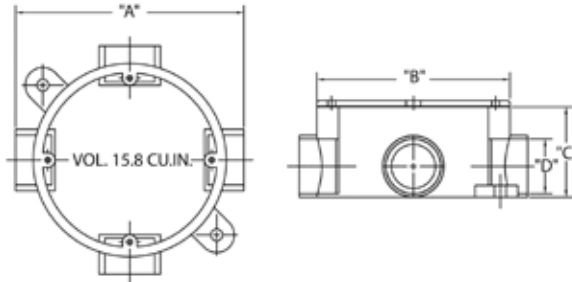

A 4" round enclosure with four entrance hubs which is surface mounted to a wall or ceiling to terminate a conduit run or join two to four conduits at a common point and to allow space for wire splices. Four screws secure a blank cover to the box.

Round Floor Box



A cylindrical enclosure designed to be embedded in a concrete floor with some excess length remaining above the plane of the floor. Excess is trimmed flush with the concrete. Sold as a kit with one leveling ring, 4 blank hubs (Stoppers), 4 reducing bushings and one polyethylene temporary pour lid.

15.0 cubic inch per inch of depth
 90.0 cubic inch maximum volume
 Minimum concrete depth - 3"

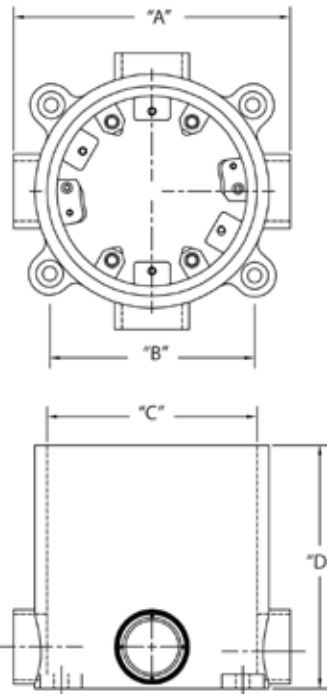

Part Number	Trade Size	Carton Quantity	"A"	"B"	"C"	"D"
5133760	Floor Box Base 4-3/4" Hubs, 4-3/4" to 1/2" Reducers, Level Ring and Pour Cover	9	6.438	3.563	4.563	6.000
5133758	Floor Box Base 2-3/4" Hubs & 2-1" Hubs 2-3/4" to 1/2" Reducers, 2-1" to 3/4" Reducers, Level Ring and Pour Cover	9	6.438	3.563	4.563	6.000

Dimensions are nominal

Duplex Cover - Bronze

Part Number	Trade Size	Carton Quantity	"A"
5133678	Duplex Cover - Bronze	10	5.500

Dimensions are nominal

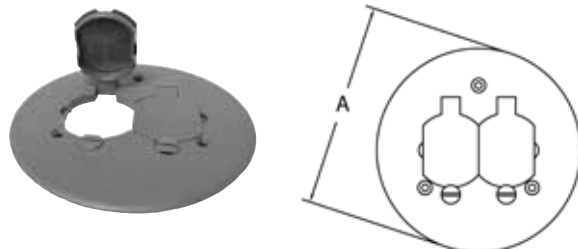

Nonmetallic PVC Junction Boxes

Junction Box

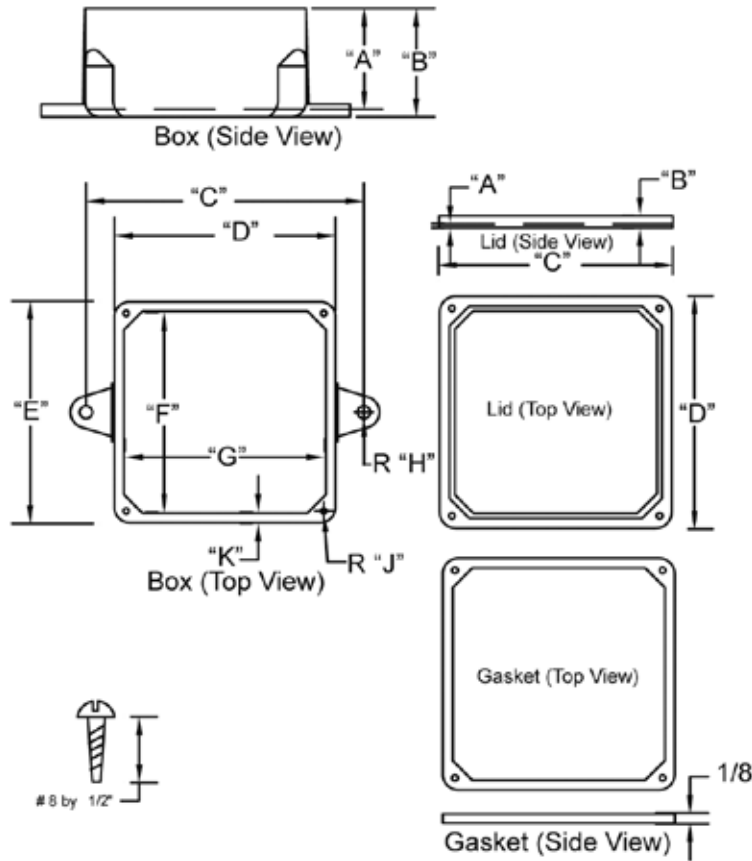

Molded Junction Box



UL Category - QCUO
UL File #E205935

NEMA Enclosure Ratings - Type 4X,

Fabricated Junction Box



Part Number	Trade Size	Description	Carton Qty.	Junction Box Base										Cover				Screws
				"A"	"B"	"C"	"D"	"E"	"F"	"G"	"H"	"J"	"K"	"A"	"B"	"C"	"D"	
5133705	4x4x2	Molded	10	2.000	2.150	5.375	4.400	4.400	4.000	4.000	250	.125	.160	.240	.370	4.375	4.375	#8 x 1/2"
5133709	4x4x4	Molded	10	4.000	4.150	5.375	4.400	4.400	4.000	4.000	250	.188	.160	.240	.700	4.375	4.375	#8 x 1/2"
5133707	4x4x6	Molded	10	6.000	6.150	5.375	4.400	4.400	4.000	4.000	250	.188	.160	.240	.370	4.375	4.375	#8 x 1/2"
5133706	5x5x2	Molded	10	2.000	2.170	6.375	5.375	5.375	5.000	5.000	250	.188	.170	.180	.267	5.375	5.375	#8 x 1/2"
5133710	6x6x4	Molded	10	4.000	4.200	7.375	6.438	6.438	6.000	6.000	250	.188	.220	.180	.350	6.750	6.750	#8 x 1/2"
5133711	6x6x6	Molded	5	6.000	6.250	7.375	6.438	6.438	6.000	6.000	250	.188	.220	.180	.350	6.750	6.750	#8 x 1/2"
5133712	8x8x4	Molded	5	4.000	4.250	9.375	8.625	8.625	8.000	8.000	250	.188	.220	.180	.350	9.000	9.000	#10 x 3/4"
5133164	8x8x6	Molded	4	6.000	6.250	9.375	8.625	8.625	8.000	8.000	250	.188	.220	.180	.350	9.000	9.000	#10 x 3/4"
5133708	8x8x7	Molded	4	7.000	7.250	9.375	8.625	8.625	8.000	8.000	250	.188	.220	.180	.350	9.000	9.000	#10 x 3/4"
5133714	12x12x4	Molded	2	4.000	4.250	13.625	12.625	12.625	11.875	11.875	250	.188	.220	.220	.437	13.000	13.000	#10 x 3/4"
5133713	12x12x6	Molded	2	6.000	6.250	13.750	12.625	12.625	11.875	11.875	250	.188	.220	.220	.437	13.000	13.000	#10 x 3/4"
**5133163	16x14x6	Fab	1	--	--	--	--	--	--	--	--	--	--	--	--	--	--	--
*5133165	24x18x8	Fab	1	--	--	--	--	--	--	--	--	--	--	--	--	--	--	--
*5133161	24x18x12	Fab	1	--	--	--	--	--	--	--	--	--	--	--	--	--	--	--
*5133166	24x24x8	Fab	1	--	--	--	--	--	--	--	--	--	--	--	--	--	--	--
*5133173	36x24x8	Fab	1	--	--	--	--	--	--	--	--	--	--	--	--	--	--	--

Dimensions are nominal

* Not UL Listed - 4X NEMA Rating

** UL Listed with only a Type 1 NEMA Rating

PVC Nonmetallic Exposed Boxes and Weatherproof Covers

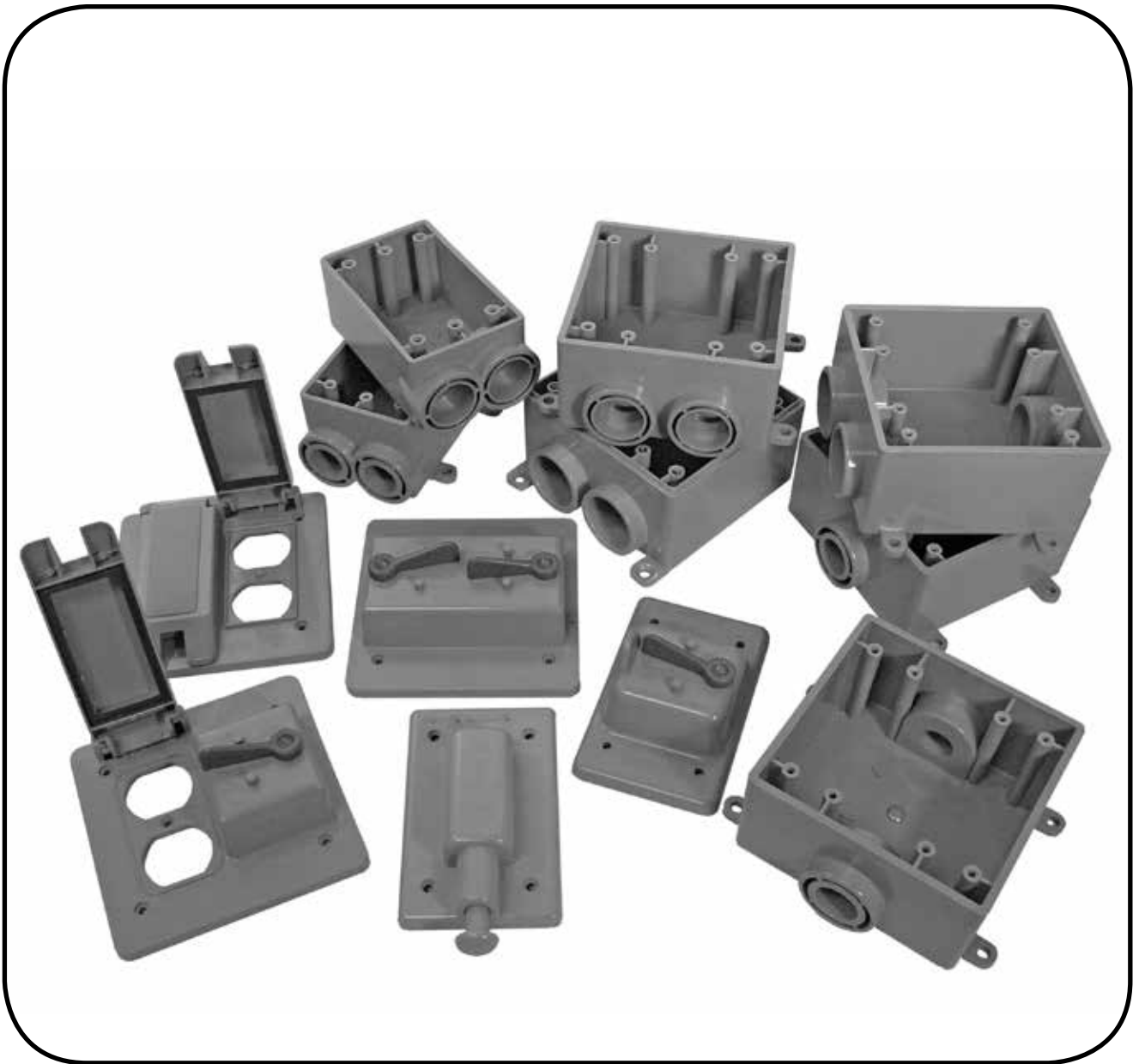

Nonmetallic PVC Exposed Electrical Boxes

Type FSC Single Gang Box



Part Number	Trade Size	Carton Quantity	"A"	"B"	"C"	"D"	"E"	"F"
5133463	1/2	10	2.813	4.563	2.625	2.375	3.438	.875
5133464	3/4	10	2.813	4.563	2.625	2.375	3.438	1.063
5133465	1	10	2.813	4.563	2.625	2.375	3.438	1.313

Dimensions are nominal

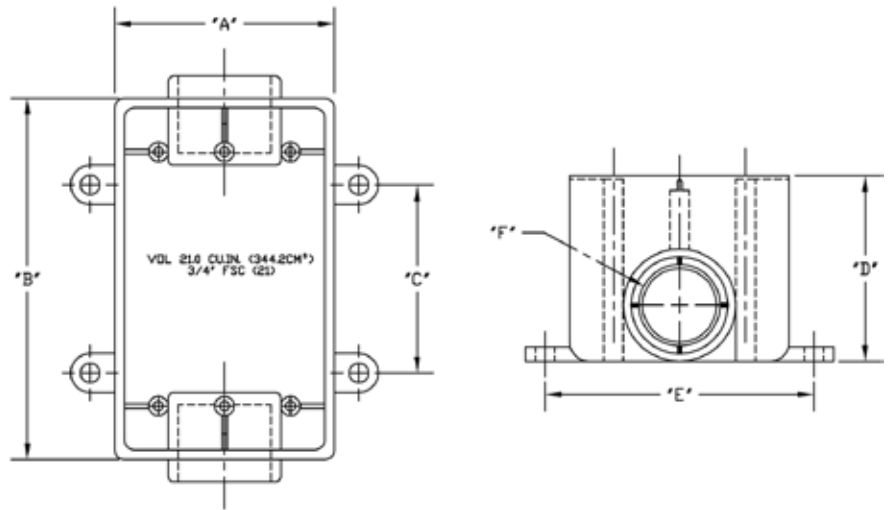

Type FSC Two Gang Box



Part Number	Trade Size	Carton Quantity	"A"	"B"	"C"	"D"	"E"	"F"
5133370	1/2	5	4.563	4.563	3.250	2.375	5.250	.875
5133371	3/4	5	4.563	4.563	3.250	2.375	5.250	1.063
5133372	1	5	4.563	4.563	3.250	2.375	5.250	1.313

Dimensions are nominal

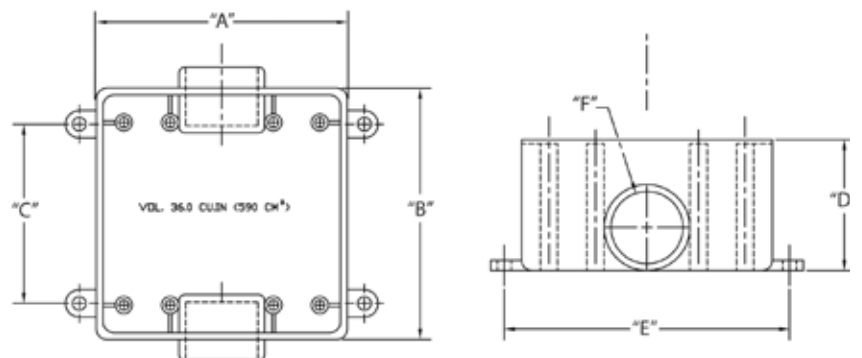

Nonmetallic PVC Exposed Electrical Boxes

Type FSE Single Gang Box



Part Number	Trade Size	Carton Quantity	"A"	"B"	"C"	"D"	"E"	"F"
5133363	1/2	10	2.875	4.563	2.625	2.375	3.438	.875
5133364	3/4	10	2.875	4.563	2.625	2.375	3.438	1.063
5133365	1	10	2.875	4.563	2.625	2.375	3.438	1.313

Dimensions are nominal

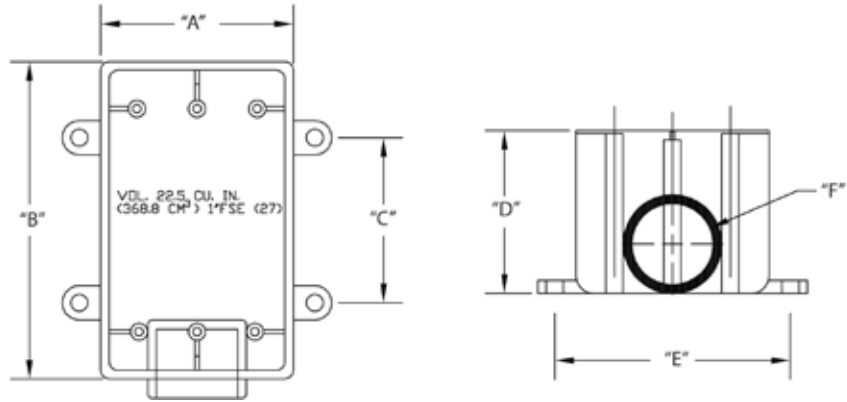

Type FSE Two Gang Box



Part Number	Trade Size	Carton Quantity	"A"	"B"	"C"	"D"	"E"	"F"
5133380	1/2	5	4.563	4.563	3.250	2.375	5.250	.875
5133381	3/4	5	4.563	4.563	3.250	2.375	5.250	1.063
5133382	1	5	4.563	4.563	3.250	2.375	5.250	1.313

Dimensions are nominal

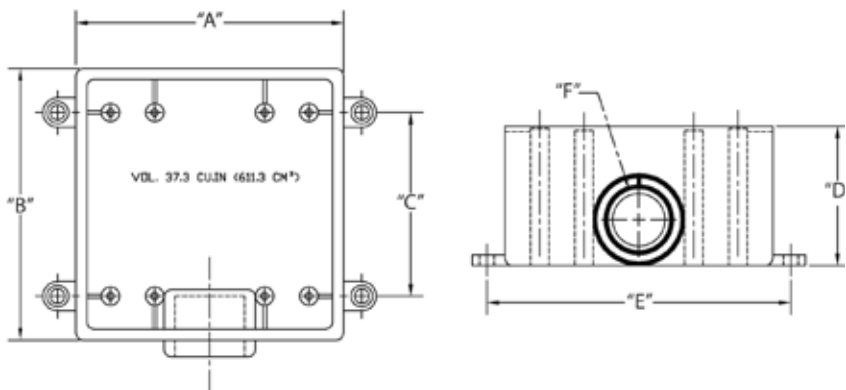

Nonmetallic PVC Exposed Electrical Boxes

Type FSS Single Gang Box



Part Number	Trade Size	Carton Quantity	"A"	"B"	"C"	"D"	"E"	"F"
5133540	1/2	10	2.813	4.625	2.625	2.375	3.500	.875
5133542	3/4	10	2.813	4.625	2.625	2.375	3.500	1.063
5133543	1	10	2.813	4.625	2.625	2.375	3.500	1.313

Dimensions are nominal

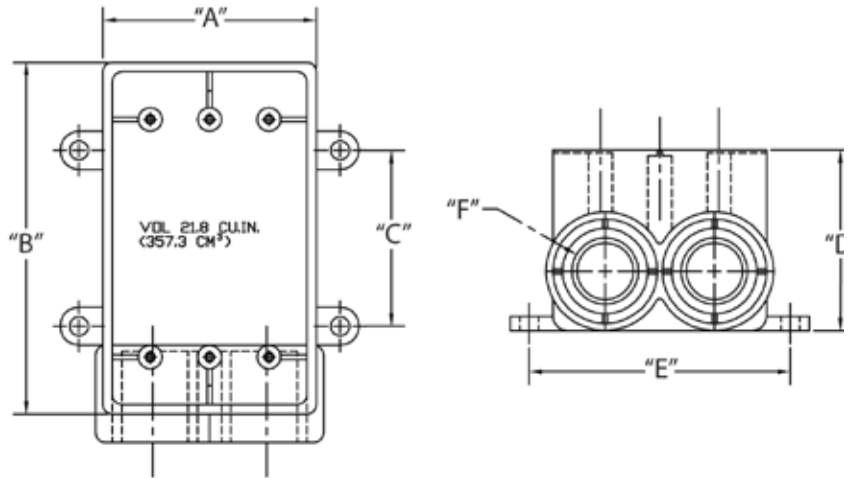

Type FSS Two Gang Box



Part Number	Trade Size	Carton Quantity	"A"	"B"	"C"	"D"	"E"	"F"
5133390	1/2	5	4.563	4.563	3.250	2.375	5.250	.875
5133391	3/4	5	4.563	4.563	3.250	2.375	5.250	1.063
5133392	1	5	4.563	4.563	3.250	2.375	5.250	1.313

Dimensions are nominal

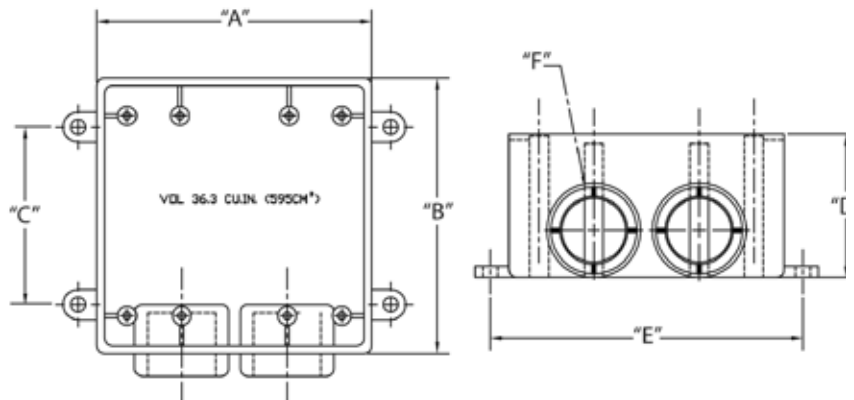

Nonmetallic PVC Exposed Electrical Boxes

Type FSCC Single Gang Box



Part Number	Trade Size	Carton Quantity	"A"	"B"	"C"	"D"	"E"	"F"
5133544	1/2	10	2.813	4.625	2.625	2.375	3.438	.875
5133545	3/4	10	2.813	4.625	2.625	2.375	3.438	1.063
5133546	1	10	2.813	4.625	2.625	2.375	3.438	1.313

Dimensions are nominal

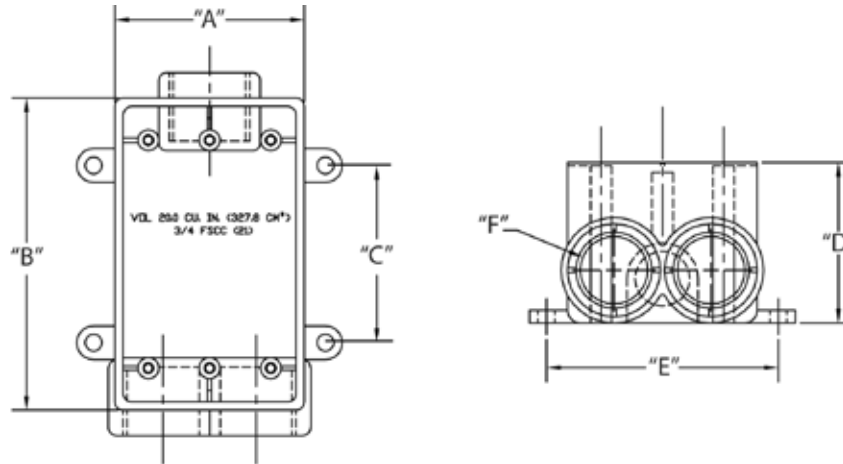

Type FSCC Two Gang Box



Part Number	Trade Size	Carton Quantity	"A"	"B"	"C"	"D"	"E"	"F"
5133400	1/2	5	4.563	4.563	3.250	2.375	5.250	.875
5133401	3/4	5	4.563	4.563	3.250	2.375	5.250	1.063
5133402	1	5	4.563	4.563	3.250	2.375	5.250	1.313

Dimensions are nominal

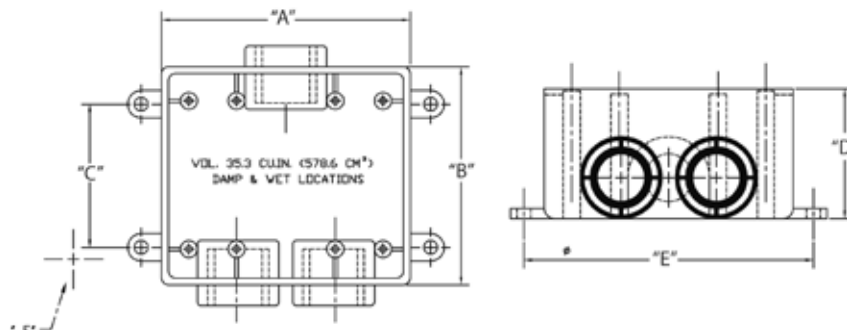

Nonmetallic PVC Exposed Electrical Boxes

Type FDC Single Gang Box



Part Number	Trade Size	Carton Quantity	"A"	"B"	"C"	"D"	"E"	"F"
5133310	1/2	10	2.563	4.563	2.625	2.938	3.500	.875
5133311	3/4	10	2.563	4.563	2.625	2.938	3.500	1.063
5133312	1	10	2.563	4.563	2.625	2.938	3.500	1.313

Dimensions are nominal

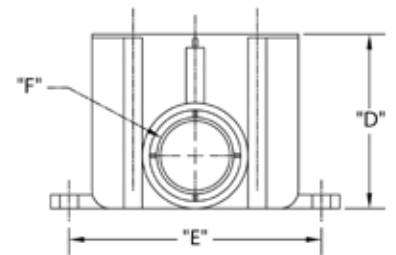
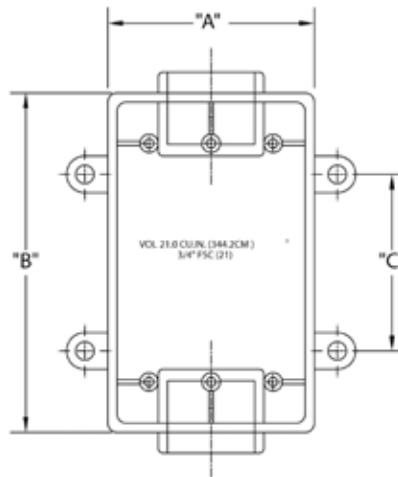

Type FDE Single Gang Box



Part Number	Trade Size	Carton Quantity	"A"	"B"	"C"	"D"	"E"
5133300	1/2	10	2.688	5.875	4.500	2.875	.875
5133301	3/4	10	2.688	5.875	4.500	2.875	1.063
5133302	1	10	2.688	5.875	4.500	2.875	1.313

Dimensions are nominal

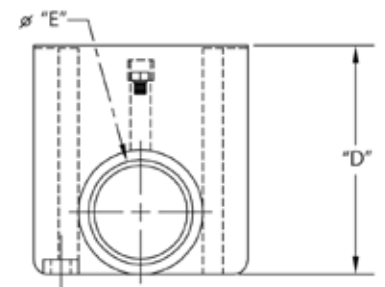
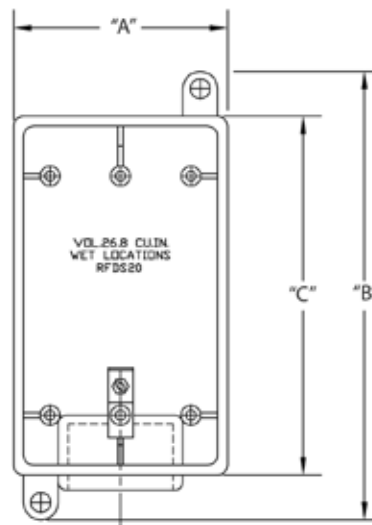

Nonmetallic PVC Exposed Electrical Boxes

Type FD-Blank Single Gang Box

Part Number	Trade Size	Carton Quantity	"A"	"B"	"C"	"D"	"E"
5133420	--	10	2.813	3.313	4.563	3.000	6.375

Dimensions are nominal

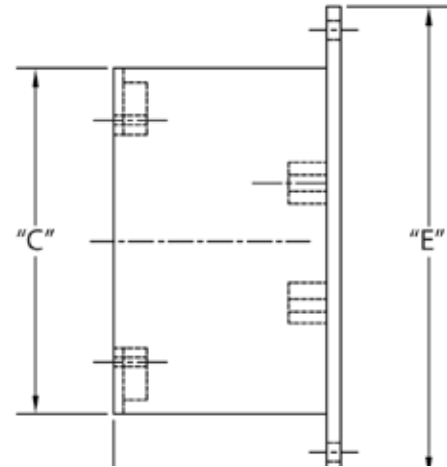
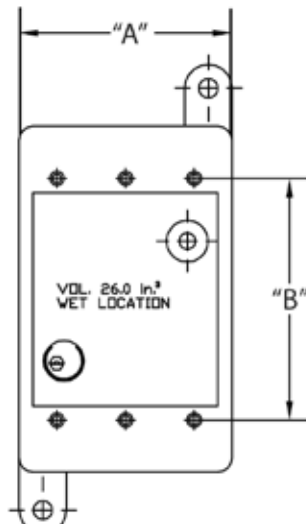

Nonmetallic PVC Weatherproof Covers

Blank Single Gang Cover



Part Number	Trade Size	Carton Quantity	"A"	"B"	"C"	"D"	"E"	"F"	"G"
5133362	--	50	4.750	3.000	1.875	3.313	2.875	4.625	4.375

Dimensions are nominal

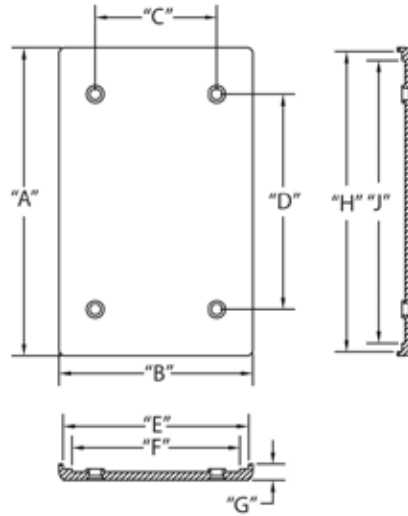

Blank Two Gang Cover



Part Number	Trade Size	Carton Quantity	"A"	"B"	"C"	"D"
5133410	--	25	4.688	4.938	3.813	3.438

Dimensions are nominal

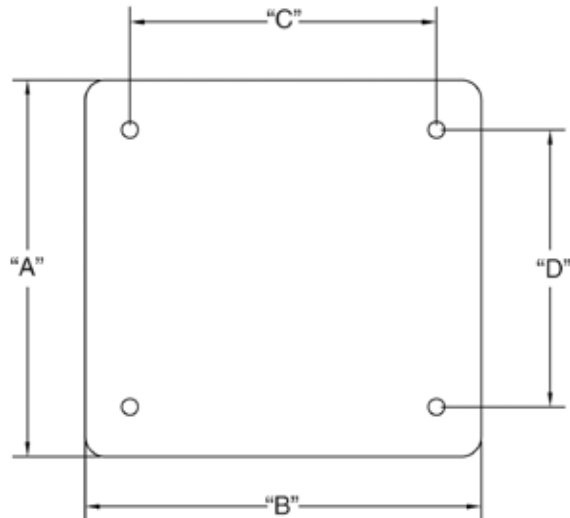

Nonmetallic PVC Weatherproof Covers

Single Gang Switch Cover



Part Number	Trade Size	Carton Quantity	"A"	"B"
5133361	--	10	2.850	5.450

Dimensions are nominal

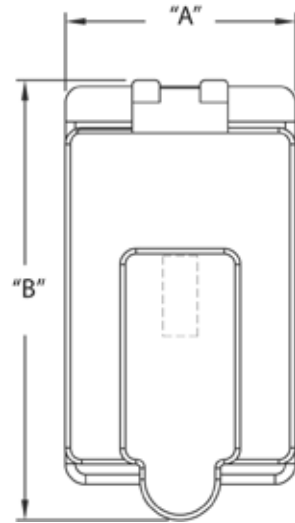

Wet locations when cover is closed.

Single Gang Toggle Switch Cover



Part Number	Trade Size	Carton Quantity	"A"	"B"	"C"	"D"
5133330	--	10	4.813	3.000	1.875	3.313

Dimensions are nominal

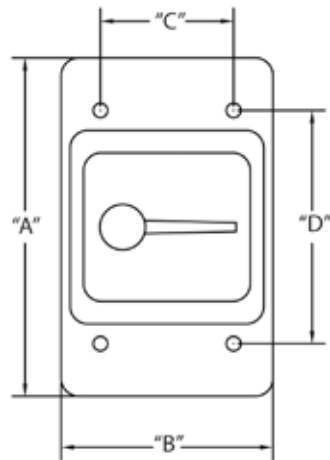

Wet locations when cover is closed.

Nonmetallic PVC Weatherproof Covers

Single Gang Single Receptacle Cover



Part Number	Trade Size	Carton Quantity	"A"	"B"	"C"
5133350	15 amp	10	2.850	4.930	1.375
5133320	20 amp	10	2.850	4.930	1.625
5133321	30 amp	10	2.850	4.930	1.722
5133322	50 amp	10	2.850	4.930	2.187

Dimensions are nominal

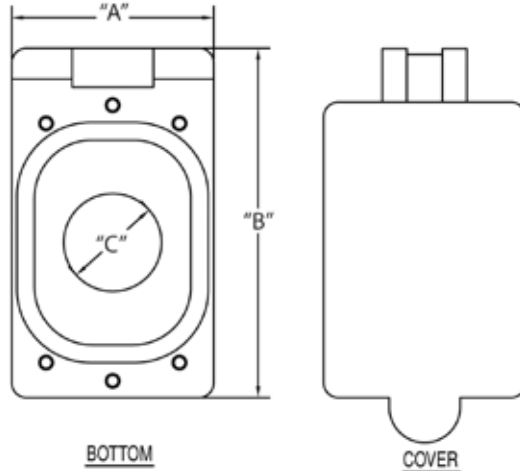

Wet locations when cover is closed.

Single Gang GFI Receptacle Cover



Part Number	Trade Size	Carton Quantity	"A"	"B"
5133348	--	10	2.850	4.930

Dimensions are nominal

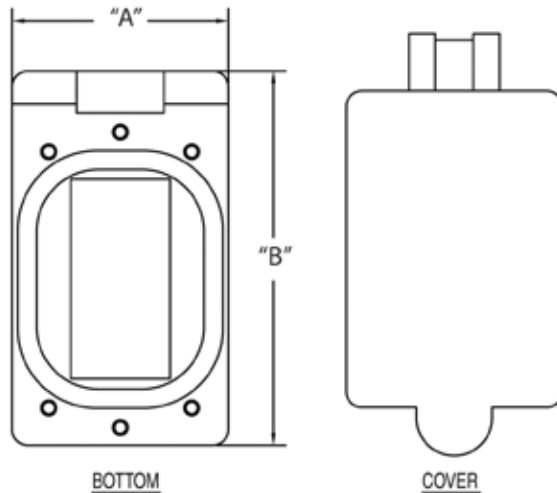

Wet locations when cover is closed.

Nonmetallic PVC Weatherproof Covers

Single Gang Duplex Receptacle Cover



Part Number	Trade Size	Carton Quantity	"A"	"B"
5133352	--	10	2.850	4.930

Dimensions are nominal

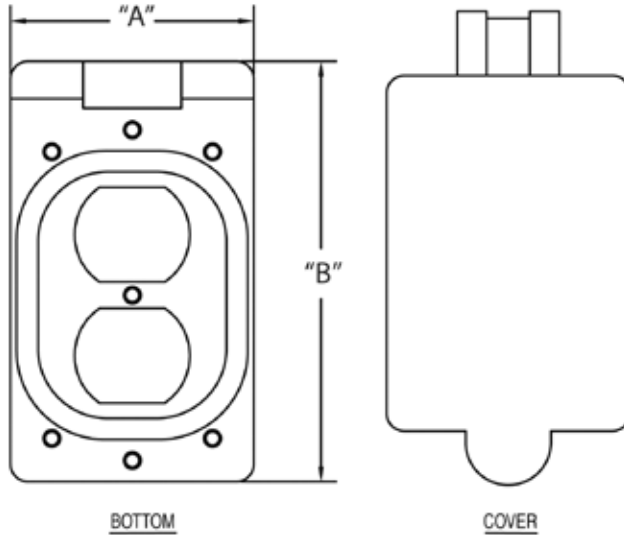

Wet locations when cover is closed.

Single Gang Plunger Switch Cover



Part Number	Trade Size	Carton Quantity	"A"	"B"	"C"	"D"	"E"
5133335	--	10	4.813	6.250	3.000	1.875	3.313

Dimensions are nominal

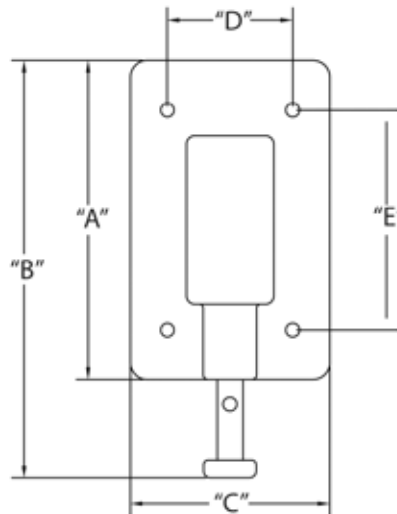

Wet locations when cover is closed.

Nonmetallic PVC Weatherproof Covers

Two Gang GFI & Toggle Switch Cover



Part Number	Trade Size	Carton Quantity	"A"	"B"	"C"	"D"
5133345	--	10	4.688	4.875	3.813	3.438

Dimensions are nominal



Wet locations when cover is closed.

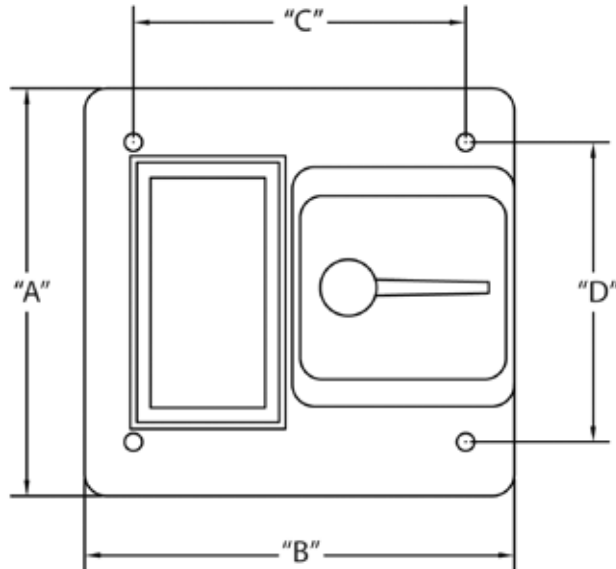

Two Gang Toggle Switch Cover



Part Number	Trade Size	Carton Quantity	"A"	"B"	"C"	"D"
5133331	--	10	4.688	4.938	3.813	3.438

Dimensions are nominal



Wet locations when cover is closed.

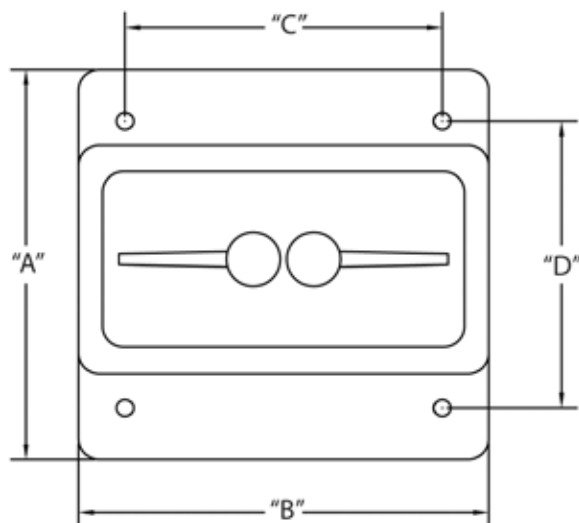

Nonmetallic PVC Weatherproof Covers

Two Gang Duplex & Toggle Switch Cover



Part Number	Trade Size	Carton Quantity	"A"	"B"	"C"	"D"
5133337	--	10	4.688	4.875	3.813	3.438

Dimensions are nominal

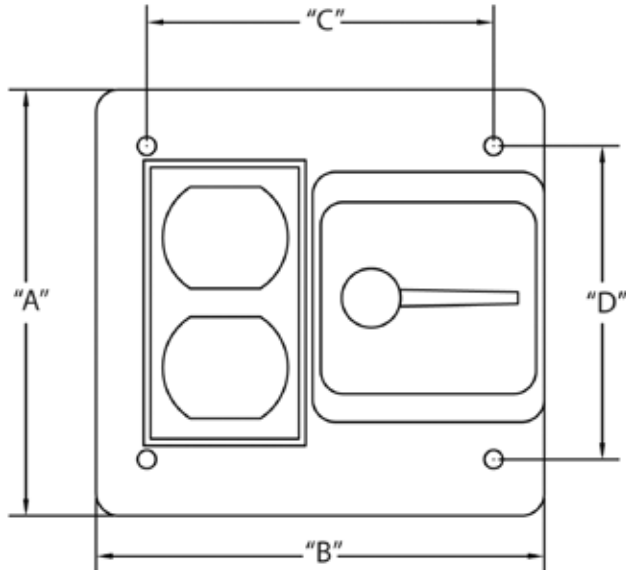

Wet locations when cover is closed.

Two Gang Double Duplex Cover



Part Number	Trade Size	Carton Quantity	"A"	"B"	"C"	"D"
5133347	--	10	4.688	4.875	3.813	3.438

Dimensions are nominal

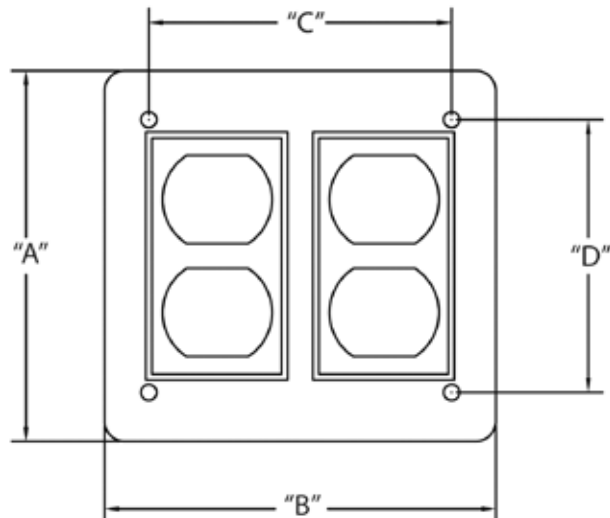

Wet locations when cover is closed.

Nonmetallic PVC Weatherproof Covers

Single Gang In-Use Cover



Part Number	Depth	Carton Quantity
5133692	2.250	6
5133694	3.625	6



Standard depth cover for 16 gage or lighter cord sets for vending machines, holiday lighting, landscape lighting and portable signs. Plug and outlet protection for any single gang application.

Meets 2005 NEC 406.8 (B) code.

15 and 20 amps, 125 and 250V receptacles installed in wet locations shall have an enclosure that is weatherproof whether or not the attachment plug cap is inserted.

Wet locations when cover is closed.



Includes three patented rotating inserts providing 16 configurations

Two Gang In-Use Cover



Part Number	Depth	Carton Quantity
5133693	2.250	6



Standard depth cover for 16 gage or lighter cord sets for vending machines, holiday lighting, landscape lighting and portable signs. Plug and outlet protection for any single gang application.

Meets 2005 NEC 406.8 (B) code.

Wet locations when cover is closed.



Includes six patented rotating inserts providing 70 configurations

Fittings for NEMA TC6 & TC8 DB & EB Utility Duct



Fittings for Type EB & DB Duct

Terminal (Male) Adapter



1/2" thru 1-1/2"

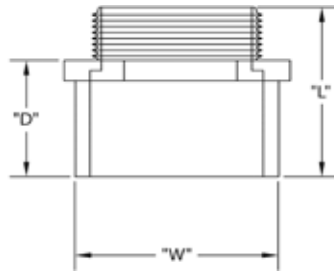

Part Number	Trade Size	Carton Qty.	"W"	"L"	"D"
5140103	1/2	200	1.063	1.688	1.125
5140104	3/4	125	1.250	1.750	1.188
5140105	1	70	1.625	2.188	1.500
5140106	1-1/4	40	2.000	2.125	1.313
5140107	1-1/2	30	2.000	2.063	1.313

Dimensions are nominal



2" and Larger

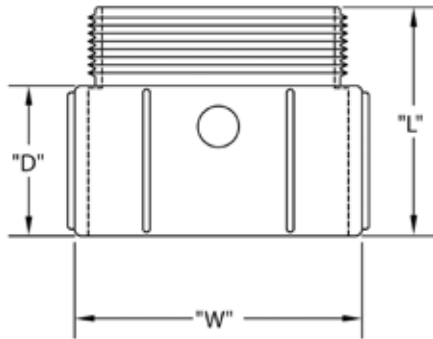

Part Number	Trade Size	Carton Qty.	"W"	"L"	"D"
5140108	2	40	2.688	2.188	1.375
5140109	2-1/2	20	3.313	2.875	2.000
5140110	3	40	3.938	3.000	2.188
5140111	3-1/2	30	4.500	3.188	2.563
5140112	4	20	5.000	3.438	2.563
5140113	5	10	6.250	4.750	3.000
5140114	6	8	7.313	4.938	2.688
5140055D	8	2	--	--	--

* Not UL Listed

Dimensions are nominal



Female Adapter

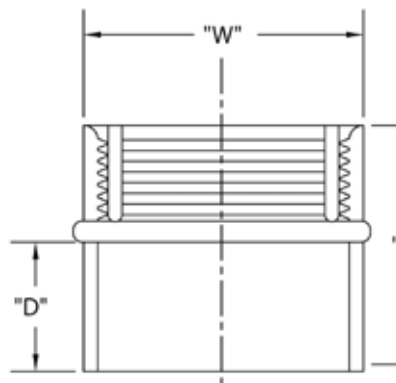

Part Number	Trade Size	Carton Qty.	"W"	"L"	"D"
5140043	1/2	200	1.000	1.438	.688
5140044	3/4	125	1.250	1.625	.688
5140045	1	70	1.563	1.875	.875
5140046	1-1/4	40	2.000	1.938	.938
5140047	1-1/2	30	2.250	2.125	.938
5140048	2	40	2.688	2.125	.938
5140049	2-1/2	20	3.313	3.000	1.313
5140050	3	40	4.000	3.063	1.250
5140051	3-1/2	30	4.500	3.000	1.188
5140052	4	20	5.000	3.250	1.375
5140053	5	10	6.125	3.688	1.313
5140054	6	8	7.250	4.375	1.625
* 5140055D	8	2	9.313	7.000	2.250

* Not UL Listed

Dimensions are nominal

Fittings for Type EB & DB Duct

TC-6 Longline Coupling with No Center Stop - Fabricated

Part Number	Trade Size	Carton Qty.	"DIA"	"A"
6121622	1-1/2	30	1.921	5.00
6121623	2	20	2.400	6.00
6121625	3	25	3.538	6.00
6121626	4	15	4.544	6.75
6121627	5	8	5.614	7.00
6121635	6	4	6.687	10.00

Dimensions are nominal

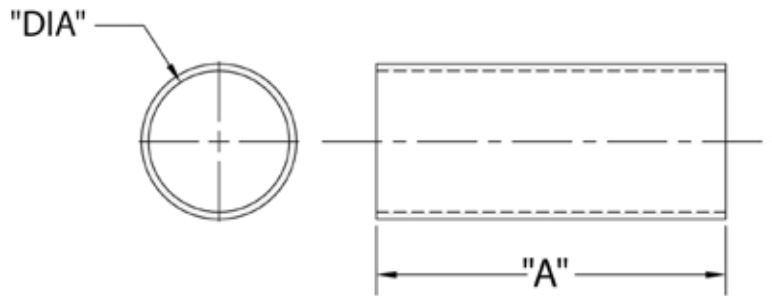

Sch. 40 Longline Coupling with Center Stop - Molded

Part Number	Trade Size	Carton Qty.	"DIA"	"A"	"B"
6202000	2	20	2.375	4.188	2.000
6202005	3	25	3.500	6.500	3.250
6202010	4	15	4.500	7.000	3.500

Dimensions are nominal

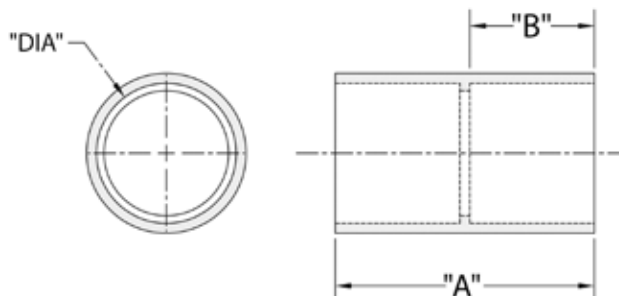

Fittings for Type EB & DB Duct

TC-6 Coupling with Center Stop - Molded

Part Number	Trade Size	Carton Qty.	"OD"	"ID"	"D"	"L"
6121636	2	50	2.500	2.375	1.125	2.500
6121637	3	25	3.875	3.500	1.625	2.375
6121638	4	20	4.875	4.500	2.375	4.875
6121639	5	8	6.000	5.500	2.500	5.375
6121640	6	8	7.000	6.625	2.125	4.500

Dimensions are nominal

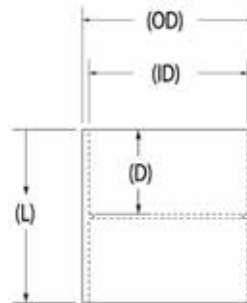

TC-6 Coupling with Center Stop - Fabricated

Part Number	Trade Size	Carton Qty.	"A"	"B"	"C"	"D"	"E"	"F"
6121617	1-1/2	30	1.921	1.906	.900	1.250	2.060	3.500
6121628	2	20	2.400	2.381	.900	2.250	2.560	5.750
6121630	3	25	3.538	3.508	.875	2.875	3.775	6.900
6121632	4	15	4.544	4.509	.750	3.000	4.875	7.250
6121633	5	8	5.614	5.573	1.100	3.250	5.975	7.875
6121634	6	4	6.687	6.636	1.250	3.500	7.100	9.000

Dimensions are nominal

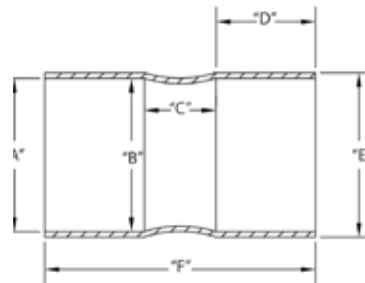

Schedule 40 5° Coupling Bell to Plain End - Molded

Part Number	Trade Size	Carton Qty.	"L1"	"L2"	"ID"	"ID-2"
6141530	3	25	4.313	4.000	3.000	3.500
6141531	4	25	5.000	4.500	3.938	4.500

Dimensions are nominal

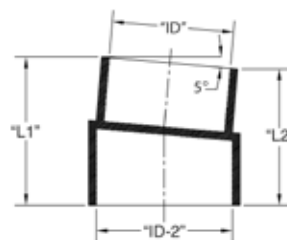

Fittings for Type EB & DB Duct

TC6 5° Coupling Bell to Bell End - Fabricated

Part Number	Trade Size	Carton Qty.	"L1"	"L2"	"BE"	"BB"	"D" Min
6151457	2	20	6.250	6.000	2.400	2.381	1.750
6151458	3	25	7.500	7.188	3.538	3.508	2.875
6151459	4	15	8.750	8.375	4.544	4.509	3.375
6151460	5	8	10.500	10.000	5.614	5.573	4.000
6151461	6	4	13.000	12.438	6.687	6.636	5.000

Dimensions are nominal

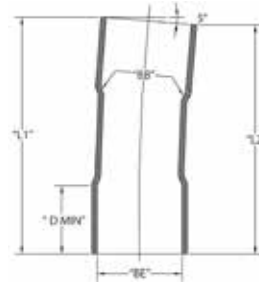

TC-6 Swedged Reducer - Bell to Plain End - Fabricated

Part Number	Trade Size	Carton Qty.	"L"	"ID"	"ID-2"	"DIA"
5142210	3x2	25	7.250	2.250	3.563	3.688
5142211	5x4	8	9.250	4.188	5.563	5.813
5142209	6x5	4	9.250	5.250	6.625	6.938

Dimensions are nominal

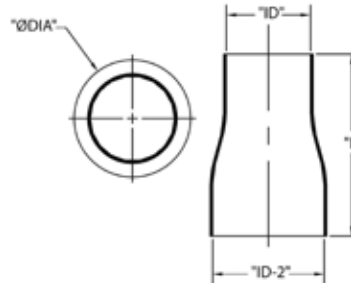

TC-6 Swedged Reducer - Bell to Bell End - Fabricated

Part Number	Trade Size	Carton Qty.	"L"	"ID"	"ID-2"	"ID-3"	"DIA"
5142212	4x3	15	9.000	3.563	3.250	4.500	4.750

Dimensions are nominal

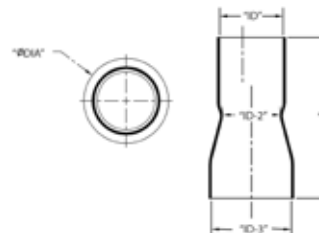

Fittings for Type EB & DB Duct

TC-6 End Bells - Fabricated

Part Number	Trade Size	Carton Qty.	"L"	"ID"	"OD"	"SD"
5124010	2	40	6.00	2.375	2.500	2.125
5124012	3	50	6.125	3.500	3.750	3.375
5124014	4	50	6.125	4.500	4.875	4.000
5124015	5	25	7.125	5.500	5.875	5.125
5124017	6	15	7.000	6.625	7.000	6.000

Dimensions are nominal

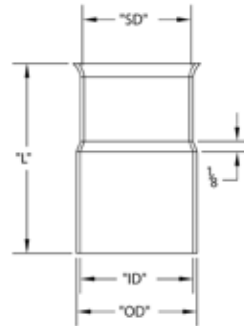

Schedule 40 Swedged Reducer - Bell to Plain End - Fabricated

Part Number	Trade Size	Carton Qty.	"L"	SPIGOT "OD"	BELL "ID"
5142102	2-1/2 x 2	20	6.625	2.375	2.890
5142104	3 x 2	25	6.688	2.375	3.515
5142105	3 x 2-1/2	25	7.313	2.875	3.515
5142107	5 x 4	8	11.375	4.500	5.593
5142108	4 x 2	10	7.375	2.375	4.515
5142109	4 x 3	15	7.813	3.500	4.515
5142107	5 x 4	8	11.313	4.500	6.658
5142203	6 x 5	4	11.188	5.563	6.658
5142204	8 x 6	2	11.250	6.625	8.670

Dimensions are nominal

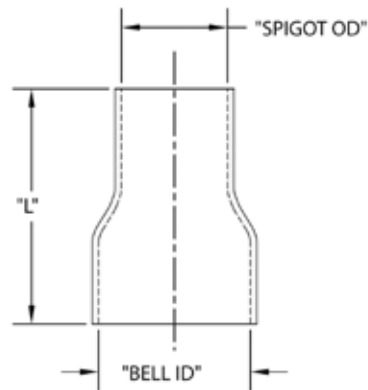

TC-6 End Bells - Molded

Part Number	Trade Size	Carton Qty.	"L"	"ID"	"OD"
5144101	1-1/2	50	1.550	2.120	2.510
5144102	2	40	1.580	2.600	2.870
5144104	3	50	2.000	3.700	4.000
5144106	4	50	2.330	4.750	5.100
5144108	5	25	2.500	5.930	6.300
5144110	6	15	2.820	6.900	7.320

Dimensions are nominal

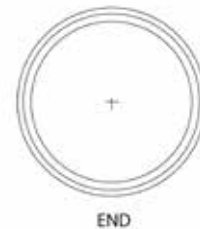
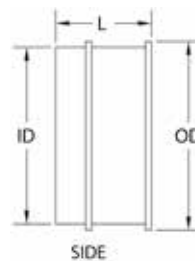

Fittings for Type EB & DB Duct

End Cap

Part Number	Trade Size	Carton Qty.	"A"	"B"
5140031	1/2	100	.875	.875
5140032	3/4	100	1.063	1.063
5140033	1	50	1.375	1.250
5140034	1-1/4	25	1.688	1.313
5140035	1-1/2	25	1.938	1.563
5140037	2	50	2.375	1.625
5140038	2-1/2	25	2.875	2.000
5140039	3	25	3.563	2.375
5140036	3-1/2	25	4.000	2.313
5140040	4	25	4.500	2.375
5140041	5	25	5.563	2.500
5140042	6	10	6.625	3.000

Dimensions are nominal

Meets NEMA TC3 Requirements
Made of Rigid PVC

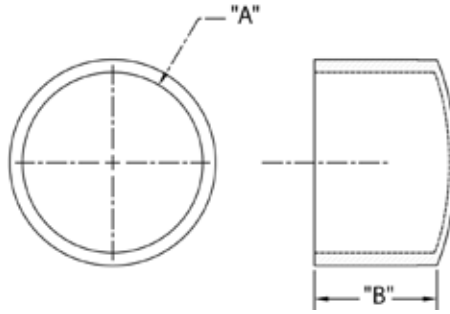

1/2" through 4" have dome top



5" and 6" have flat top

Poly Plug

Part Number	Trade Size	Carton Qty.	"L"	"D-1"	"D-2"
5315248	2	70	3.250	1.875	2.438
5315250	3	70	3.813	2.625	3.438
5315252	4	90	4.063	3.688	4.438
5315253	5	45	3.813	4.750	5.500
5315254	6	30	3.813	5.563	6.500

Dimensions are nominal

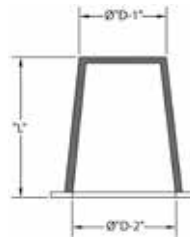

Poly Plug with Pulling Eye

Part Number	Trade Size	Carton Qty.	"L"	"D-1"	"D-2"
5315258	2	70	3.000	2.000	2.500
5315260	3	45	3.750	2.875	3.500
5315262	4	80	3.875	3.750	4.500
5315263	5	45	3.750	4.875	5.625
5315264	6	35	3.875	5.625	6.875

Dimensions are nominal

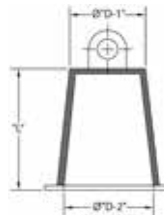

Rigid Nonmetallic EB & DB Elbows - Special Radius

DBHM-60 90° Elbow for Type EB & DB Duct Special Radius - Bell End

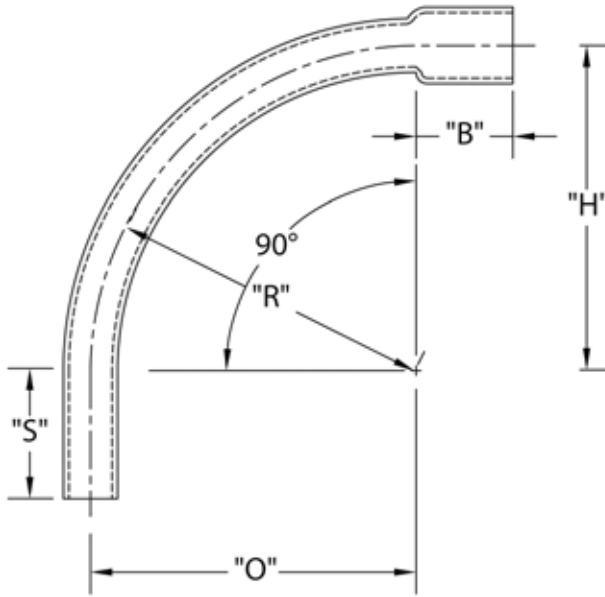

DBHM-60 90° Elbow 36" Radius Bell End

Part Number	Trade Size	"R"	"O"	"H"	"S" MIN	"B" MIN	"L"
5123868	2	36.000	36.000	36.000	2.000	2.000	56.500
5123872	3	36.000	36.000	36.000	3.125	2.500	56.500
5123876	4	36.000	36.000	36.000	3.375	3.250	56.500
5123880	5	36.000	36.000	36.000	3.625	4.250	56.500
5123884	6	36.000	36.000	36.000	3.750	5.000	56.500

Dimensions are nominal

DBHM-60 90° Elbow 48" Radius Bell End

Part Number	Trade Size	"R"	"O"	"H"	"S" MIN	"B" MIN	"L"
5123865	2	48.000	48.000	48.000	2.000	2.000	75.375
5123869	3	48.000	48.000	48.000	3.125	2.500	75.375
5123877	4	48.000	48.000	48.000	3.375	3.250	75.375
5123881	5	48.000	48.000	48.000	3.625	4.250	75.375
5123894	6	48.000	48.000	48.000	3.750	5.000	75.375

Dimensions are nominal

DBHM-60 90° Elbow 18" Radius Bell End

Part Number	Trade Size	"R"	"O"	"H"	"S" MIN	"B" MIN	"L"
5123866	2	18.000	18.000	18.000	2.000	2.000	28.250
5123870	3	18.000	18.000	18.000	3.125	2.500	28.250
5123874	4	18.000	18.000	18.000	3.375	3.250	28.250

Dimensions are nominal

DBHM-60 90° Elbow 24" Radius Bell End

Part Number	Trade Size	"R"	"O"	"H"	"S" MIN	"B" MIN	"L"
5123867	2	24.000	24.000	24.000	2.000	2.000	37.688
5123871	3	24.000	24.000	24.000	3.125	2.500	37.688
5123875	4	24.000	24.000	24.000	3.375	3.250	37.688
5123879	5	24.000	24.000	24.000	3.625	4.250	37.688

Dimensions are nominal

DBHM-60 90° Elbow 60" Radius Bell End

Part Number	Trade Size	"R"	"O"	"H"	"S" MIN	"B" MIN	"L"
5123806	2	60.000	60.000	60.000	2.000	2.000	94.250
5123810	3	60.000	60.000	60.000	3.125	2.500	94.250
5123878	4	60.000	60.000	60.000	3.375	3.250	94.250
5123899	5	60.000	60.000	60.000	3.625	4.250	94.250
5123895	6	60.000	60.000	60.000	3.750	5.000	94.250

Dimensions are nominal

Rigid Nonmetallic EB & DB Elbows - Special Radius

DBHM-60 45° Elbow Special Radius - Bell End

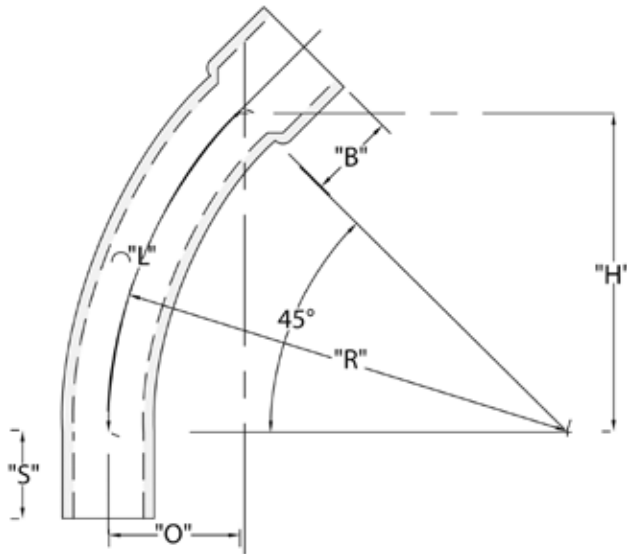

DBHM-60 45° Elbow 36" Radius Bell End

Part Number	Trade Size	"R"	"O"	"H"	"S" MIN	"B" MIN	"L"
5123768	2	36.000	4.813	18.000	2.000	2.000	18.875
5123772	3	36.000	4.813	18.000	3.125	2.500	18.875
5123776	4	36.000	4.813	18.000	3.375	3.250	18.875
5123780	5	36.000	4.813	18.000	3.625	4.250	18.875
5123784	6	36.000	4.813	18.000	3.750	5.000	18.875

Dimensions are nominal

DBHM-60 45° Elbow 48" Radius Bell End

Part Number	Trade Size	"R"	"O"	"H"	"S" MIN	"B" MIN	"L"
5123769	2	48.000	6.438	24.000	2.000	2.000	25.125
5123745	3	48.000	6.438	24.000	3.125	2.500	25.125
5123779	4	48.000	6.438	24.000	3.375	3.250	25.125
5123781	5	48.000	6.438	24.000	3.625	4.250	25.125
5123794	6	48.000	6.438	24.000	3.750	5.000	25.125

Dimensions are nominal

DBHM-60 45° Elbow 18" Radius Bell End

Part Number	Trade Size	"R"	"O"	"H"	"S" MIN	"B" MIN	"L"
5123766	2	18.000	2.438	9.063	2.000	2.000	9.438
5123803	3	18.000	2.438	9.063	3.125	2.500	9.438
5123807	4	18.000	2.438	9.063	3.375	3.250	9.438

Dimensions are nominal

DBHM-60 45° Elbow 24" Radius Bell End

Part Number	Trade Size	"R"	"O"	"H"	"S" MIN	"B" MIN	"L"
5123767	2	24.000	3.188	12.000	2.000	2.000	12.563
5123771	3	24.000	3.188	12.000	3.125	2.500	12.563
5123775	4	24.000	3.188	12.000	3.375	3.250	12.563
5123789	5	24.000	3.188	12.000	3.625	4.250	12.563

Dimensions are nominal

DBHM-60 45° Elbow 60" Radius Bell End

Part Number	Trade Size	"R"	"O"	"H"	"S" MIN	"B" MIN	"L"
5123748	4	60.000	8.063	30.000	3.375	3.250	31.438
5123782	5	60.000	8.063	30.000	3.625	4.250	31.438
5123795	6	60.000	8.063	30.000	3.750	5.000	31.438

Dimensions are nominal

Rigid Nonmetallic EB & DB Elbows - Special Radius

DBHM-60 30° Elbow Special Radius - Bell End

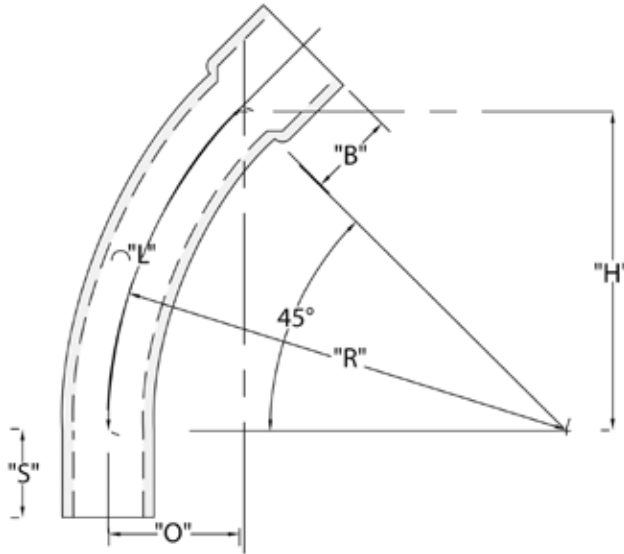

DBHM-60 30° Elbow 18" Radius Bell End

Part Number	Trade Size	"R"	"O"	"H"	"S" MIN	"B" MIN	"L"
5123785	2	18.000	2.438	9.063	2.000	2.000	9.438
5123757	3	18.000	2.438	9.063	3.125	2.500	9.438

Dimensions are nominal

DBHM-60 30° Elbow 24" Radius Bell End

Part Number	Trade Size	"R"	"O"	"H"	"S" MIN	"B" MIN	"L"
5123799	2	24.000	3.188	12.000	2.000	2.000	12.563
5123802	3	24.000	3.188	12.000	3.125	2.500	12.563
5123712	4	24.000	3.188	12.000	3.375	3.250	12.563

Dimensions are nominal

DBHM-60 30° Elbow 36" Radius Bell End

Part Number	Trade Size	"R"	"O"	"H"	"S" MIN	"B" MIN	"L"
5123770	2	36.000	4.813	18.000	2.000	2.000	18.875
5123759	3	36.000	4.813	18.000	3.125	2.500	18.875
5123760	4	36.000	4.813	18.000	3.375	3.250	18.875
5123761	5	36.000	4.813	18.000	3.625	4.250	18.875
5123918	6	36.000	4.813	18.000	3.750	5.000	18.875

Dimensions are nominal

DBHM-60 30° Elbow 48" Radius Bell End

Part Number	Trade Size	"R"	"O"	"H"	"S" MIN	"B" MIN	"L"
5123950	2	48.000	6.438	24.000	2.000	2.000	25.125
5123951	3	48.000	6.438	24.000	3.125	2.500	25.125
5123919	4	48.000	6.438	24.000	3.375	3.250	25.125
5123959	5	48.000	6.438	24.000	3.625	4.250	25.125
5123920	6	48.000	6.438	24.000	3.750	5.000	25.125

Dimensions are nominal

DBHM-60 30° Elbow 60" Radius Bell End

Part Number	Trade Size	"R"	"O"	"H"	"S" MIN	"B" MIN	"L"
5123812	2	60.000	8.063	30.000	2.000	2.000	31.438
5123952	3	60.000	8.063	30.000	3.125	2.500	31.438
5123764	4	60.000	8.063	30.000	3.375	3.250	31.438
5123746	5	60.000	8.063	30.000	3.625	4.250	31.438
5123921	6	60.000	8.063	30.000	3.750	5.000	31.438

Dimensions are nominal

Rigid Nonmetallic EB & DB Elbows - Special Radius

DBHM-60 22-1/2° Elbow Special Radius - Bell End

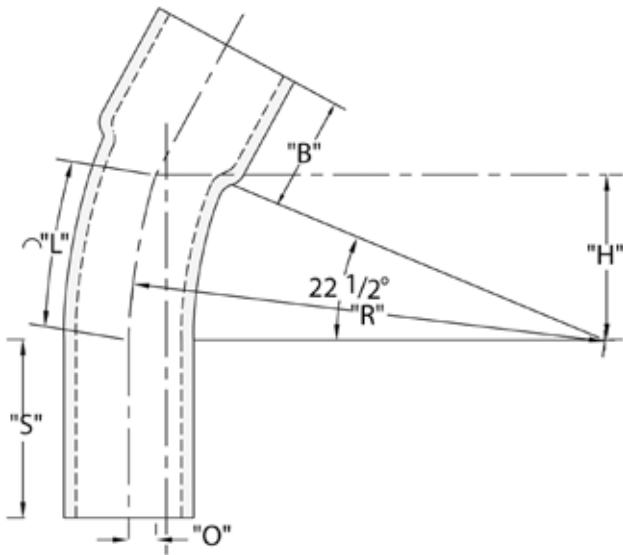

DBHM-60 22-1/2° Elbow 36" Radius Bell End

Part Number	Trade Size	"R"	"O"	"H"	"S" MIN	"B" MIN	"L"
5123800	2	36.000	2.750	13.750	2.000	2.000	14.125
5123755	3	36.000	2.750	13.750	3.125	2.500	14.125
5123750	4	36.000	2.750	13.750	3.375	3.250	14.125
5123751	5	36.000	2.750	13.750	3.625	4.250	14.125
5123730	6	36.000	2.750	13.750	3.750	5.000	14.125

Dimensions are nominal

DBHM-60 22-1/2° Elbow 48" Radius Bell End

Part Number	Trade Size	"R"	"O"	"H"	"S" MIN	"B" MIN	"L"
5123811	2	48.000	3.625	18.375	2.000	2.000	18.875
5123946	3	48.000	3.625	18.375	3.125	2.500	18.875
5123738	4	48.000	3.625	18.375	3.375	3.250	18.875
5123739	5	48.000	3.625	18.375	3.625	4.250	18.875
5123931	6	48.000	3.625	18.375	3.750	5.000	18.875

Dimensions are nominal

DBHM-60 22-1/2° Elbow 18" Radius Bell End

Part Number	Trade Size	"R"	"O"	"H"	"S" MIN	"B" MIN	"L"
5123940	2	18.000	1.375	6.875	2.000	2.000	7.063
5123945	3	18.000	1.375	6.875	3.125	2.500	7.063
5123740	4	18.000	1.375	6.875	3.375	3.250	7.063

Dimensions are nominal

DBHM-60 22-1/2° Elbow 24" Radius Bell End

Part Number	Trade Size	"R"	"O"	"H"	"S" MIN	"B" MIN	"L"
5125831	1-1/2	24.000	1.813	9.188	2.000	2.000	9.438
5123744	2	24.000	1.813	9.188	2.000	2.000	9.438
5123801	3	24.000	1.813	9.188	3.125	2.500	9.438
5123753	4	24.000	1.813	9.188	3.375	3.250	9.438

Dimensions are nominal

DBHM-60 22-1/2° Elbow 60" Radius Bell End

Part Number	Trade Size	"R"	"O"	"H"	"S" MIN	"B" MIN	"L"
5123728	2	60.000	4.563	23.000	2.000	2.000	23.563
5123947	3	60.000	4.563	23.000	3.125	2.500	23.563
5123735	4	60.000	4.563	23.000	3.375	3.250	23.563
5123736	5	60.000	4.563	23.000	3.625	4.250	23.563
5123732	6	60.000	4.563	23.000	3.750	5.000	23.563

Dimensions are nominal

Rigid Nonmetallic EB & DB Elbows - Special Radius

DBHM-60 11-1/4° Elbow Special Radius - Bell End

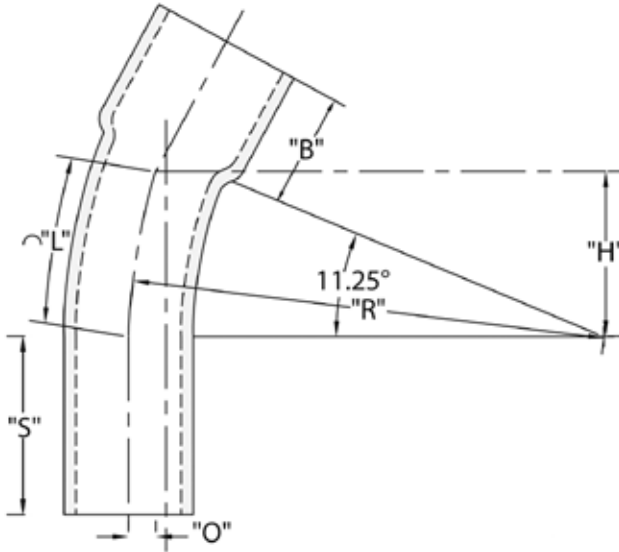

DBHM-60 11-1/4° Elbow 36" Radius Bell End

Part Number	Trade Size	"R"	"O"	"H"	"S" MIN	"B" MIN	"L"
5123938	2	36.000	.688	7.000	2.000	2.000	7.063
5123704	3	36.000	.688	7.000	3.125	2.500	7.063
5123720	4	36.000	.688	7.000	3.375	3.250	7.063
5123724	5	36.000	.688	7.000	3.625	4.250	7.063
5123725	6	36.000	.688	7.000	3.750	5.000	7.063

Dimensions are nominal

DBHM-60 11-1/4° Elbow 48" Radius Bell End

Part Number	Trade Size	"R"	"O"	"H"	"S" MIN	"B" MIN	"L"
5123937	4	48.000	.938	9.375	3.375	3.250	9.438
5123722	5	48.000	.938	9.375	3.625	4.250	9.438
5123932	6	48.000	.938	9.375	3.750	5.000	9.438

Dimensions are nominal

DBHM-60 11-1/4° Elbow 24" Radius Bell End

Part Number	Trade Size	"R"	"O"	"H"	"S" MIN	"B" MIN	"L"
5123711	3	24.000	.469	.688	3.375	2.500	4.719
5123700	4	24.000	.469	.688	3.125	3.250	4.719
5123729	5	24.000	.469	.688	3.625	4.250	4.719

Dimensions are nominal

DBHM-60 11-1/4° Elbow 150" Radius Bell End

Part Number	Trade Size	"R"	"O"	"H"	"S" MIN	"B" MIN	"L"
5123703	3	150.000	2.875	29.250	3.125	2.500	29.438
5123792	5	150.000	2.875	29.250	3.625	4.250	29.438
5123733	6	150.000	2.875	29.250	3.750	5.000	29.438

Dimensions are nominal

Rigid Nonmetallic EB & DB Elbows - Special Radius

DBHM-120 90° Elbow for Type EB & DB Duct Special Radius - Bell End

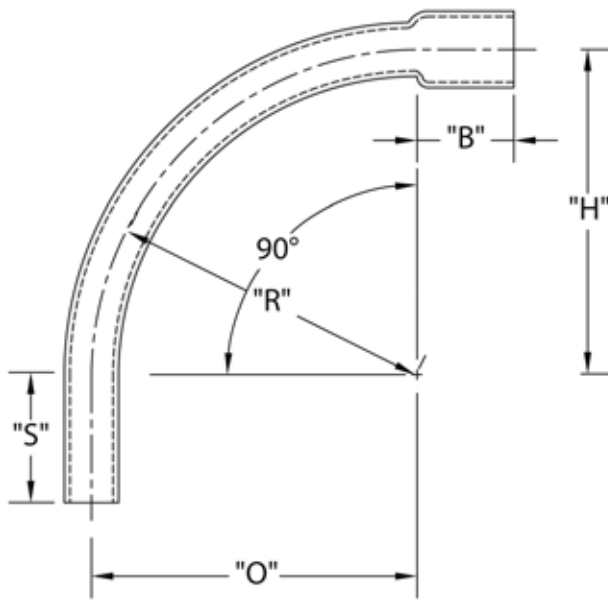

DBHM-120 90° Elbow 36" Radius Bell End

Part Number	Trade Size	"R"	"O"	"H"	"S" MIN	"B" MIN	"L"
5123862	1-1/2	36.000	36.000	36.000	2.000	2.000	56.500
5125869	2	36.000	36.000	36.000	2.000	2.000	56.500
5125872	3	36.000	36.000	36.000	3.125	2.500	56.500
5125876	4	36.000	36.000	36.000	3.375	3.250	56.500
5125880	5	36.000	36.000	36.000	3.625	4.250	56.500
5125884	6	36.000	36.000	36.000	3.750	5.000	56.500

Dimensions are nominal

DBHM-120 90° Elbow 48" Radius Bell End

Part Number	Trade Size	"R"	"O"	"H"	"S" MIN	"B" MIN	"L"
5123863	1-1/2	48.000	48.000	48.000	2.000	2.000	75.375
5125740	2	48.000	48.000	48.000	2.000	2.000	75.375
5125741	3	48.000	48.000	48.000	3.125	2.500	75.375
5125877	4	48.000	48.000	48.000	3.375	3.250	75.375
5125901	5	48.000	48.000	48.000	3.625	4.250	75.375
5125885	6	48.000	48.000	48.000	3.750	5.000	75.375

Dimensions are nominal

DBHM-120 90° Elbow 18" Radius Bell End

Part Number	Trade Size	"R"	"O"	"H"	"S" MIN	"B" MIN	"L"
5123861	1-1/2	18.000	18.000	18.000	2.000	2.000	28.250
5125862	2	18.000	18.000	18.000	2.000	2.000	28.250
5125870	3	18.000	18.000	18.000	3.125	2.500	28.250
5125874	4	18.000	18.000	18.000	3.375	3.250	28.250

Dimensions are nominal

DBHM-120 90° Elbow 24" Radius Bell End

Part Number	Trade Size	"R"	"O"	"H"	"S" MIN	"B" MIN	"L"
5125742	1-1/2	24.000	24.000	24.000	2.000	2.000	37.688
5125881	2	24.000	24.000	24.000	2.000	2.000	37.688
5125871	3	24.000	24.000	24.000	3.125	2.500	37.688
5125875	4	24.000	24.000	24.000	3.375	3.250	37.688
5125898	5	24.000	24.000	24.000	3.625	4.250	37.688

Dimensions are nominal

DBHM-120 90° Elbow 60" Radius Bell End

Part Number	Trade Size	"R"	"O"	"H"	"S" MIN	"B" MIN	"L"
5125859	2	60.000	60.000	60.000	2.000	2.000	94.250
5125873	3	60.000	60.000	60.000	3.125	2.500	94.250
5125878	4	60.000	60.000	60.000	3.375	3.250	94.250
5125899	5	60.000	60.000	60.000	3.625	4.250	94.250
5125895	6	60.000	60.000	60.000	3.750	5.000	94.250

Dimensions are nominal

Rigid Nonmetallic EB & DB Elbows - Special Radius

DBHM-120 45° Elbow Special Radius - Bell End

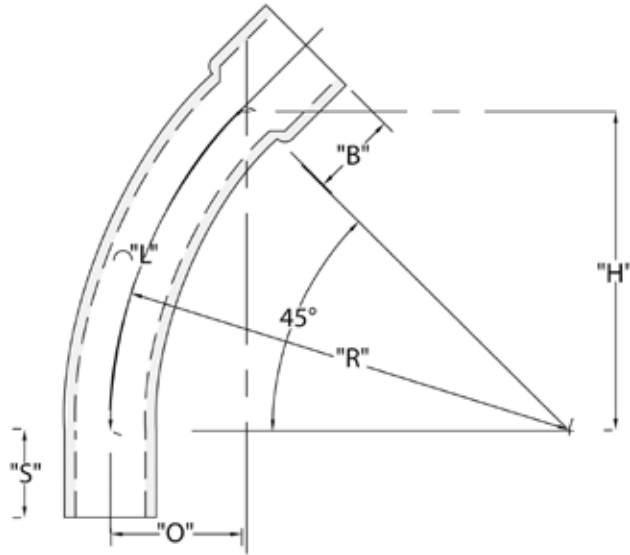

DBHM-120 45° Elbow 18" Radius Bell End

Part Number	Trade Size	"R"	"O"	"H"	"S" MIN	"B" MIN	"L"
5125746	2	18.000	2.438	9.063	2.000	2.000	9.438
5125747	3	18.000	2.438	9.063	3.125	2.500	9.438

Dimensions are nominal

DBHM-120 45° Elbow 24" Radius Bell End

Part Number	Trade Size	"R"	"O"	"H"	"S" MIN	"B" MIN	"L"
5125815	1-1/2	24.000	3.188	12.000	2.000	2.000	12.563
5125767	2	24.000	3.188	12.000	2.000	2.000	12.563
5125774	3	24.000	3.188	12.000	3.125	2.500	12.563
5125753	4	24.000	3.188	12.000	3.375	3.250	12.563

Dimensions are nominal

DBHM-120 45° Elbow 36" Radius Bell End

Part Number	Trade Size	"R"	"O"	"H"	"S" MIN	"B" MIN	"L"
5125736	1-1/2	36.000	4.813	18.000	2.000	2.000	18.875
5125879	2	36.000	4.813	18.000	2.000	2.000	18.875
5125772	3	36.000	4.813	18.000	3.125	2.500	18.875
5125776	4	36.000	4.813	18.000	3.375	3.250	18.875
5125781	5	36.000	4.813	18.000	3.625	4.250	18.875
5125784	6	36.000	4.813	18.000	3.750	5.000	18.875

Dimensions are nominal

DBHM-120 45° Elbow 48" Radius Bell End

Part Number	Trade Size	"R"	"O"	"H"	"S" MIN	"B" MIN	"L"
5125769	2	48.000	6.438	24.000	2.000	2.000	25.125
5125737	3	48.000	6.438	24.000	3.125	2.500	25.125
5125744	4	48.000	6.438	24.000	3.375	3.250	25.125
5125783	5	48.000	6.438	24.000	3.625	4.250	25.125
5125796	6	48.000	6.438	24.000	3.750	5.000	25.125

Dimensions are nominal

DBHM-120 45° Elbow 60" Radius Bell End

Part Number	Trade Size	"R"	"O"	"H"	"S" MIN	"B" MIN	"L"
5125748	3	60.000	8.063	30.000	3.125	2.500	31.438
5125738	4	60.000	8.063	30.000	3.375	3.250	31.438
5125782	5	60.000	8.063	30.000	3.625	4.250	31.438
5125795	6	60.000	8.063	30.000	3.750	5.000	31.438

Dimensions are nominal

Rigid Nonmetallic EB & DB Elbows - Special Radius

DBHM-120 30° Elbow Special Radius - Bell End

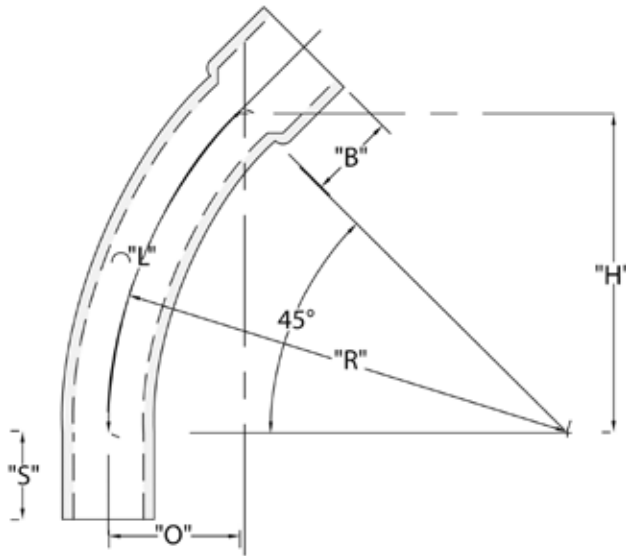

DBHM-120 30° Elbow 36" Radius Bell End

Part Number	Trade Size	"R"	"O"	"H"	"S" MIN	"B" MIN	"L"
5125842	1-1/2	36.000	4.813	18.000	2.000	2.000	18.875
5125754	3	36.000	4.813	18.000	3.125	2.500	18.875
5125761	4	36.000	4.813	18.000	3.375	3.250	18.875
5125792	5	36.000	4.813	18.000	3.625	4.250	18.875

Dimensions are nominal

DBHM-120 30° Elbow 48" Radius Bell End

Part Number	Trade Size	"R"	"O"	"H"	"S" MIN	"B" MIN	"L"
5125762	4	48.000	6.438	24.000	3.375	3.250	25.125
5125813	6	48.000	6.438	24.000	3.750	5.000	25.125

Dimensions are nominal

DBHM-120 30° Elbow 18" Radius Bell End

Part Number	Trade Size	"R"	"O"	"H"	"S" MIN	"B" MIN	"L"
5125751	2	18.000	2.438	9.063	2.000	2.000	9.438
5125841	3	18.000	2.438	9.063	3.125	2.500	9.438

Dimensions are nominal

DBHM-120 30° Elbow 24" Radius Bell End

Part Number	Trade Size	"R"	"O"	"H"	"S" MIN	"B" MIN	"L"
5125818	5	24.000	3.188	12.000	2.000	4.250	12.563

Dimensions are nominal

DBHM-120 30° Elbow 60" Radius Bell End

Part Number	Trade Size	"R"	"O"	"H"	"S" MIN	"B" MIN	"L"
5125819	4	60.000	8.063	30.000	3.375	3.250	31.438
5125803	5	60.000	8.063	30.000	3.625	4.250	31.438
5125816	6	60.000	8.063	30.000	3.750	5.000	31.438

Dimensions are nominal

Service Entrance Caps, Meter Offsets, Risers and Spacers



Type EB/DB Accessories

Service Entrance Cap - 1/2" thru 1"

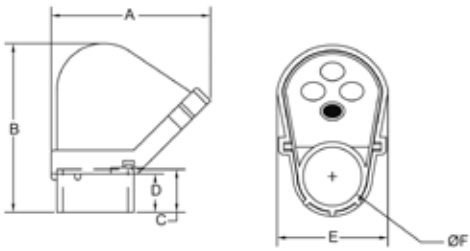

Part Number	Trade Size	Carton Qty.	"A"	"B"	"C"	"D"	"E"	"ØF"
5133590	1/2	10	2.875	2.875	.750	.625	2.188	.852
5133591	3/4	10	2.875	2.875	.875	.438	2.125	1.064
5133741	1	20	3.313	3.625	1.000	.750	2.375	1.330

Dimensions are nominal



Service Entrance Cap - 1-1/4" thru 2"

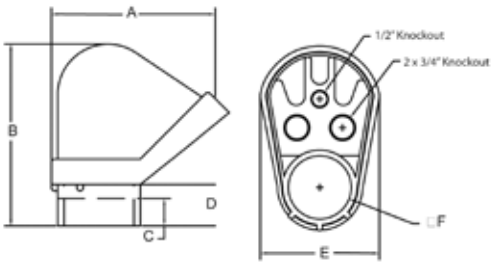

Part Number	Trade Size	Carton Qty.	"A"	"B"	"C"	"D"	"E"	"ØF"
5133742	1-1/4	20	5.000	5.000	1.250	1.375	3.313	1.667
5133695	1-1/2	20	6.500	6.500	1.750	2.000	4.250	1.918
5133743	2	5	6.500	6.500	1.750	2.000	4.250	2.393

Dimensions are nominal



Service Entrance Cap - 2-1/2" thru 3"

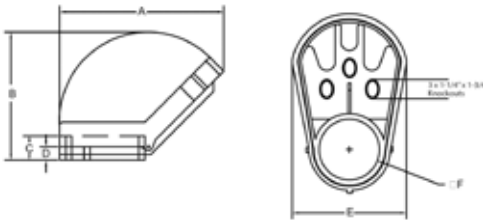

Part Number	Trade Size	Carton Qty.	"A"	"B"	"C"	"D"	"E"	"ØF"
5133696	2-1/2	5	15.000	8.250	1.875	1.000	8.250	2.890
5133697	3	5	12.250	9.375	1.750	1.000	8.250	3.515

Dimensions are nominal



Service Entrance Cap - 3-1/2" thru 4"

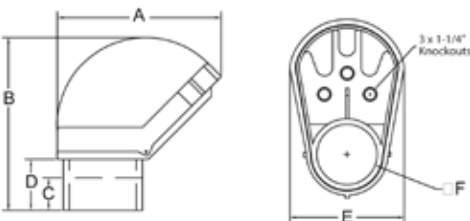

Part Number	Trade Size	Carton Qty.	"A"	"B"	"C"	"D"	"E"	"ØF"
5133698	3-1/2	5	12.500	11.000	2.000	3.125	8.000	4.015
5133699	4	1	16.000	11.000	2.750	2.500	10.250	4.515

Dimensions are nominal



Type EB/DB Accessories

Meter Offset

Part Number	Trade Size	Carton Qty.	Thread Size	"ID"	"ID-2"	"OD"
5133183	1-1/4	15	1.625	1.625	1.375	2.000
5133185	2	8	2.313	2.375	2.000	2.188

Dimensions are nominal

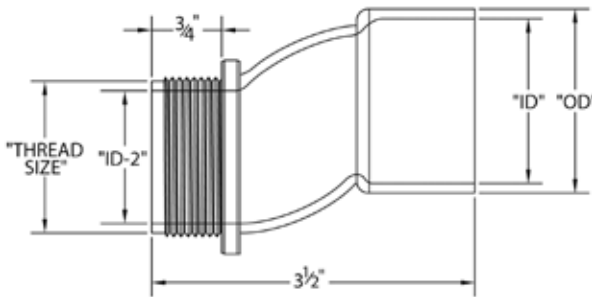

Used to connect a conduit to a meter box. The offset is needed to move the path of the conduit away from a wall into the holes in a box or meter box.



Conduit Offset

Part Number	Trade Size	Carton Qty.	"L"	"ID"	"DIA"
5133188	1/2	25	6.375	.625	.875
5133189	3/4	25	6.375	.750	1.063

Dimensions are nominal



Plain end section of conduit formed to go around obstacles or compensate for centerline differences in two conduits.

Made from listed Conduit.



Type EB/DB Accessories

Fabricated Expansion Joint (Meter Riser)

Assembled from ETL listed product.
Material is Rigid PVC

Part Number	Trade Size	Carton Qty.	"L"	"ID"	"ID-2"	"DIA"
5144028	2	16	26.625	2.000	2.375	2.750
5144043	3	12	24.000	3.000	3.500	4.000

Dimensions are nominal

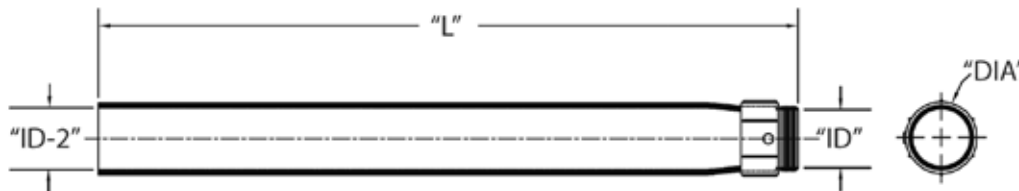

Fabricated Expansion Joint (Meter Riser)

CANTEX PVC Schedule 40 and 80 Service Risers provide permanent protection for underground services where they emerge from the ground to enter structures or enclosures.

Formed from ETL Listed **CANTEX** PVC Schedule 40 and 80 conduit, these risers are resistant to impact, will not corrode and eliminate shock hazards.

Their use assures compliance with Article 300-5 of the National Electrical Code.

INCLUDES TERMINAL (MALE) ADAPTER CEMENTED AT TOP END.

7' Lengths

Rated for 90° Cable

Schedule 40

Part Number	Trade Size	Carton Qty.	"OD" (Nom)	"T" (Min)	TA Trade Size	"L"
5133726	2	140	2.375	.154	2.000	140
5133728	2-1/2	135	2.875	.203	2.500	140
5133730	3	81	3.500	.216	3.000	140
5136008	4	51	4.500	.237	4.000	140

Dimensions are nominal

Schedule 80

Part Number	Trade Size	Carton Qty.	"OD" (Nom)	"T" (Min)	TA Trade Size	"L"
5133729	2	140	2.375	.218	2.000	140
5133731	3	81	3.500	.300	3.000	140
5133732	4	51	4.500	.337	4.000	140

Dimensions are nominal

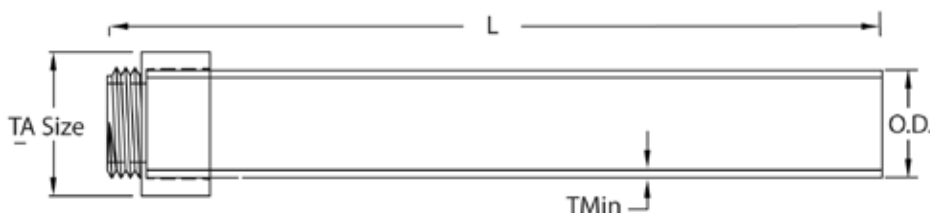

Type EB/DB Accessories

Schedule 40 & 80 Service Riser with 45° Bend, Bell End

CANTEX PVC Schedule 40 and DB-120 Service Risers with a 40° bend provide permanent protection for underground services where they emerge from the ground. The 45° bend eliminates the cost, time and labor to install a separate elbow. Formed from ETL Listed **CANTEX** Schedule 40 and DB-120 conduit that are resistant and UV light, their use assures compliance with Article 300-5 of the National Electrical Code.

Part Number	Size	Description	Carton Qty.	"R"	"O"	"S"	"B" Min.	"L"	"H"	"W"
5283768	2	Sch. 40 45° Hockey Stick	1	24.00	7.00	38.00	2.00	19.00	60.00	14.00

Dimensions are nominal

Part Number	Size	Description	Carton Qty.	"R"	"O"	"S"	"B" Min.	"L"	"H"	"W"
5122030	2	Sch. 80 45° x 24" Radius w/60" Riser	1	24.00	7.00	38.00	2.00	19.00	60.00	14.00
5222035	2-1/2	Sch. 80 45° x 24" Radius w/63.5" Riser	1	24.00	7.00	38.00	2.50	19.00	60.00	14.00
5122032	3	Sch. 80 45° x 24" Radius w/60" Riser	1	24.00	7.00	38.00	3.00	19.00	60.00	14.00
5122039	4	Sch. 80 45° x 24" Radius w/60" Riser	1	24.00	7.00	38.00	4.00	19.00	60.00	14.00
5122037	2-1/2	Sch. 80 45° x 24" Radius w/80" Riser	1	24.00	7.00	58.00	4.00	19.00	80.00	14.00
5122033	3	Sch. 80 45° x 24" Radius w/80" Riser	1	24.00	7.00	58.00	4.00	19.00	80.00	14.00
5122038	4	Sch. 80 45° x 24" Radius w/80" Riser	1	24.00	7.00	58.00	4.00	19.00	80.00	14.00

Dimensions are nominal

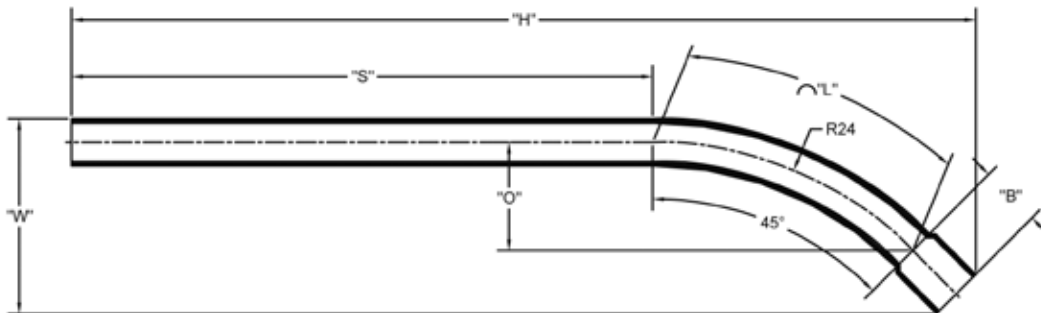

DBHM-120 Service Riser with 45° Bend, Bell End

Formed of DBHM-120 CONDUIT. Use allows installation to meet requirements of NEC(2011) Article 300.50. Not for exposed applications.

Part Number	Size	Description	Carton Qty.
5283766	1	DB120 45° x 24" Radius	1

Base Spacers

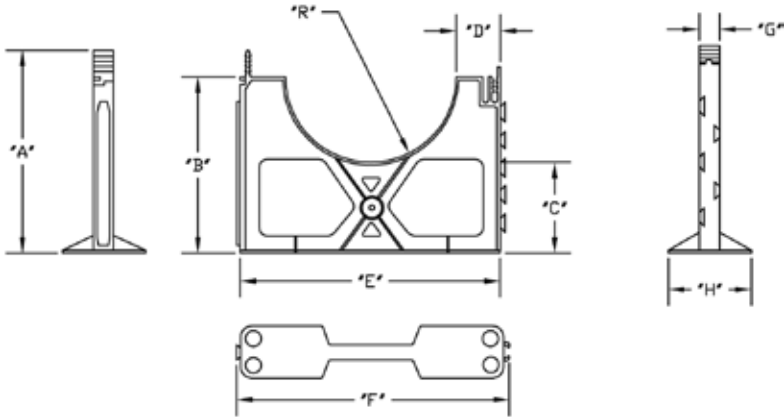

Material is Polystyrene

Part Number	Size	Carton Qty.	"A"	"B"	"C"	"D"	"E"	"F"	"G"	"H"	"R"
5335961	2 x 1-1/2	100	4.875	4.250	3.000	.750	4.000	4.250	1.000	3.000	1.250
5335977	2 x 2	100	4.875	4.250	3.000	1.000	4.500	4.750	1.000	3.000	1.250
5335979	2 x 3	100	4.875	4.250	3.000	1.500	5.500	5.750	1.000	3.000	1.250
5335963	3 x 1-1/2	90	5.500	4.750	3.000	.750	5.125	5.375	1.000	3.000	1.813
5335964	3 x 2	80	5.500	4.750	3.000	1.000	5.625	5.875	1.000	3.000	1.813
5335975	3 x 3	70	5.500	4.750	3.000	1.150	6.625	6.875	1.000	3.000	1.813
5335971	4 x 1	80	5.938	5.250	3.000	.500	5.625	5.875	1.000	3.000	2.313
5335968	4 x 1-1/2	75	5.938	5.313	3.000	.750	6.125	6.375	1.000	3.000	2.313
5335967	4 x 2	70	5.938	5.313	3.000	1.000	6.625	6.875	1.000	3.000	2.313
5335969	4 x 3	65	5.938	5.250	3.000	1.500	7.625	7.875	1.000	3.000	2.313
5335980	5 x 1-1/2	60	6.500	5.813	3.000	.750	7.813	7.438	1.000	3.000	2.875
5335976	5 x 2	60	6.500	5.813	3.000	1.000	7.688	7.938	1.000	3.000	2.875
5335978	5 x 3	50	6.500	5.813	3.000	1.500	8.688	8.938	1.000	3.000	2.875
5336039	6 x 1-1/2	50	7.000	6.375	3.000	.750	8.250	8.500	1.000	3.000	3.375
5336051	6 x 2	50	7.000	6.375	3.000	1.000	8.750	9.000	1.000	3.000	3.375
5336040	6 x 3	50	7.000	6.375	3.000	1.500	9.750	10.000	1.000	3.000	3.375

Dimensions are nominal

Type EB/DB Accessories

Intermediate Spacers

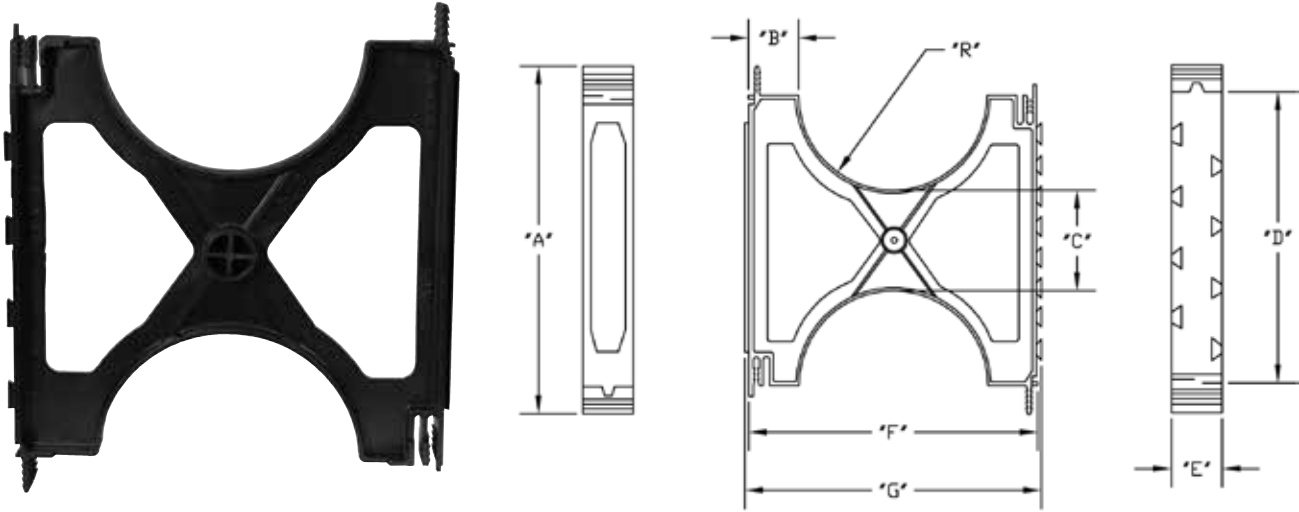

Material is Polystyrene

Part Number	Size	Carton Qty.	"A"	"B"	"C"	"D"	"E"	"F"	"G"	"R"
5336000	2 x 1-1/2	200	5.188	.750	1.375	3.875	1.000	4.000	4.250	1.250
5336018	2 x 2	170	5.688	1.000	1.875	4.375	1.000	4.500	4.750	1.250
5336032	2 x 3	110	6.688	1.500	2.875	5.375	1.000	5.500	5.750	1.250
5336016	3 x 1-1/2	140	6.313	.750	1.375	5.000	1.000	5.125	5.375	1.250
5336020	3 x 2	110	6.750	1.000	1.875	5.438	1.000	5.625	5.875	1.813
5336031	3 x 3	75	7.813	1.500	2.875	6.500	1.000	6.625	6.875	1.250
5336017	4 x 1	105	7.000	.500	1.125	5.750	1.000	5.625	5.875	2.313
5336021	4 x 1-1/2	100	7.313	.750	1.375	6.000	1.000	6.125	6.375	2.313
5336019	4 x 2	80	7.813	1.000	1.875	6.500	1.000	6.625	6.875	2.313
5336024	4 x 3	55	8.813	1.500	2.875	7.500	1.000	7.625	7.875	2.313
5336028	5 x 1-1/2	75	8.375	.750	1.375	7.000	1.000	7.188	7.438	2.875
5336029	5 x 2	55	8.875	1.000	1.875	7.500	1.000	7.688	7.938	2.875
5336030	5 x 3	45	9.875	1.500	2.875	8.500	1.000	8.688	8.938	2.875
5336038	6 x 1-1/2	50	9.438	.750	1.500	8.125	1.000	8.250	8.500	3.375
5336050	6 x 2	45	9.938	1.000	2.000	8.625	1.000	8.750	9.000	3.375
5336041	6 x 3	40	10.938	1.500	3.000	9.625	1.000	9.750	10.000	3.375

Dimensions are nominal

Plastic Spacers for Duct

Vertical and Horizontal Interlocking
For completely enclosed and locked-in duct banks

- They snap together vertically for fast, secure field assembly.
- Only two components, base and intermediate, are needed. Banding is not necessary.
- With the Vertical-Lock spacer, ducts are accurately separated. Spacers lock firmly together, preventing separation while workmen walk atop the bank.
- Alignment of the duct bank sections is relatively easy with this completely locked-in construction.
- To prevent the top tier from floating during encased burial, it is suggested that an intermediate spacer be used as a cap.
- Used in both EB and DB installations.
- Vertical and horizontal interlocking permits building a strong, locked-in duct bank. A wide baseplate provides solid support for heaviest loads.

Nominal Size	1" Separation			1-1/2" Separation			2" Separation			3 Separation		
	R	A	C	R	A	C	R	A	C	R	A	C
2				1.2	4.0	1.5	1.2	4.5	2.0	1.2	5.5	3.0
3				1.8	5.1	1.5	1.8	5.6	2.0	1.8	6.6	3.0
4	2.3	5.6	1.0	2.3	6.1	1.5	2.3	6.6	2.0	2.3	7.6	3.0
5				2.9	7.3	1.5	2.9	7.9	2.0	2.9	8.9	3.0
6				3.3	8.2	1.5	3.4	8.7	2.0	3.4	9.8	3.0

Base spacers provide a 3" separation between bottom row of ducts & trench floor, except for 4" x 1" which is 1-3/4".

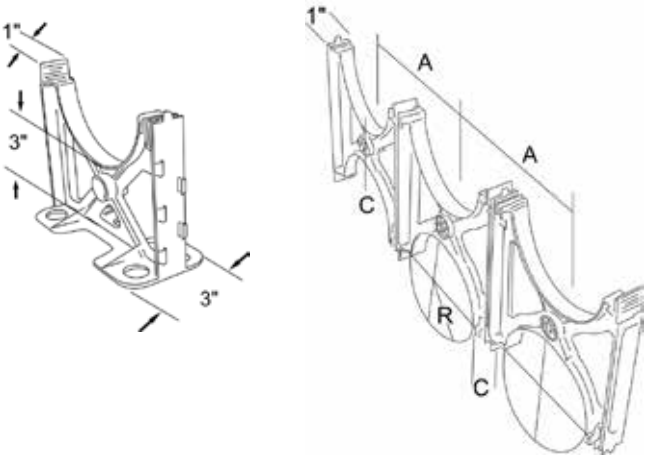

Conduit, Utility Duct and P&C Flexible Duct



Rigid Nonmetallic Schedule 40 Conduit

Meets specifications of UL 651 and NEMA TC2
 Rated for 90°C Cable
 Sunlight Resistant
 10' Lengths



Nonmetallic PVC Schedule 40 Conduit Belled End - 10' Lengths

Part No.	Size	Feet per Pack	T Min	OD	ID Min	E	B	D Nom	L Min
A52AE12	1/2	6,000	.109	.840	.578	.852	.836	1.500	120
A52AE12H	1/2	3,000	.109	.840	.578	.852	.836	1.500	120
A52AG12	3/4	4,400	.113	1.050	.780	1.064	1.046	1.750	120
A52AG12H	3/4	2,200	.113	1.050	.780	1.064	1.046	1.750	120
A52BA12	1	3,600	.133	1.315	1.004	1.330	1.310	2.000	120
A52BA12H	1	1,800	.133	1.315	1.004	1.330	1.310	2.000	120
A52BC12	1-1/4	3,300	.140	1.660	1.335	1.677	1.655	2.250	120
A52BC12H	1-1/4	1,650	.140	1.660	1.335	1.677	1.655	2.250	120
A52BE12	1-1/2	2,250	.145	1.900	1.564	1.918	1.894	2.500	120
A52BE12H	1-1/2	900	.145	1.900	1.564	1.918	1.894	2.500	120
A52CA12	2	1,400	.154	2.375	2.021	2.393	2.369	3.000	120
A52CE12	2-1/2	930	.203	2.875	2.414	2.890	2.868	3.250	120
A52DA12	3	880	.216	3.500	3.008	3.515	3.492	3.750	120
A52DE12	3-1/2	630	.226	4.000	3.486	4.015	3.992	4.000	120
A52EA12	4	570	.237	4.500	3.961	4.515	4.491	4.500	120
A52FA12	5	380	.258	5.563	4.975	5.593	5.553	5.500	120
A52GA12	6	260	.280	6.625	5.986	6.658	6.614	6.125	120
A52JA12*	8	180	.322	8.625	7.853	8.670	8.610	6.375	120

* Not ETL Listed

Dimensions are nominal

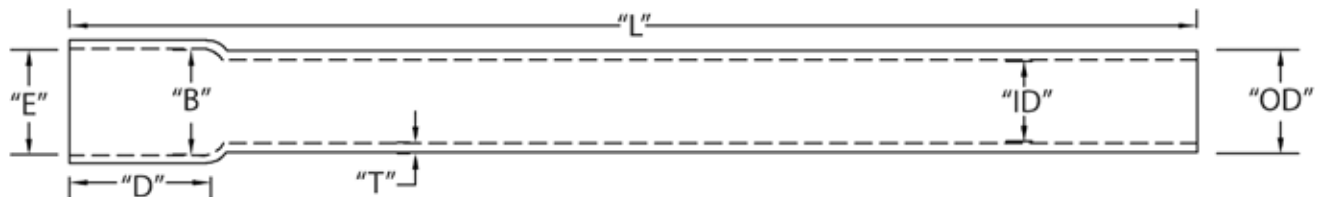

Note: 20' length available on request

Schedule 40 conduit complies with federal and military specifications by conforming to UL 651

Rigid Nonmetallic Schedule 80 Conduit

Meets specifications of UL 651 and NEMA TC2
 Rated for 90°C Cable
 Sunlight Resistant
 10' Lengths



Nonmetallic PVC Schedule 80 Conduit Belled End - 10' Lengths

Part No.	Size	Feet per Pack	T Min	OD	ID Min	E	B	D Nom	L Min
A53AE12	1/2	6,000	.147	.840	.502	.852	.836	1.500	120
A53AE12H	1/2	3,000	.147	.840	.502	.852	.836	1.500	120
A53AG12	3/4	4,400	.154	1.050	.698	1.064	1.046	1.750	120
A53AG12H	3/4	2,200	.154	1.050	.698	1.064	1.046	1.750	120
A53BA12	1	3,600	.179	1.315	.910	1.330	1.310	2.000	120
A53BA12H	1	1,800	.179	1.315	.910	1.330	1.310	2.000	120
A53BC12	1-1/4	3,300	.191	1.660	1.227	1.677	1.655	2.250	120
A53BC12H	1-1/4	1,650	.191	1.660	1.227	1.677	1.655	2.250	120
A53BE12	1-1/2	2,250	.200	1.900	1.446	1.918	1.894	2.500	120
A53BE12H	1-1/2	900	.200	1.900	1.446	1.918	1.894	2.500	120
A53CA12	2	1,400	.218	2.375	1.881	2.393	2.369	3.000	120
A53CE12	2-1/2	930	.276	2.875	2.250	2.890	2.868	3.250	120
A53DA12	3	880	.300	3.500	2.820	3.515	3.492	3.750	120
A53EA12	4	570	.337	4.500	3.737	4.515	4.491	4.500	120
A53FA12	5	380	.375	5.563	4.713	5.593	5.553	5.500	120
A53GA12	6	260	.432	6.625	5.646	6.658	6.614	6.125	120

Dimensions are nominal

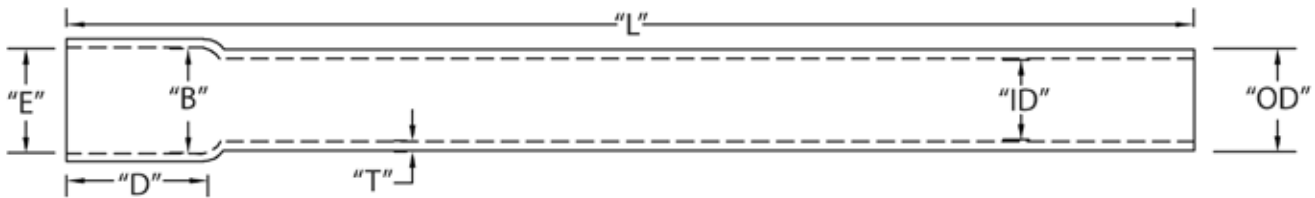

Note: 20' length available on request
 Schedule 80 conduit complies with federal and military specifications by conforming to UL 651

Rigid Nonmetallic Cellular Core PVC Conduit & Utility Duct

Meets UL 651 specifications - Not ETL Listed
 Meets NEMA TC2 requirements
 Sunlight Resistant
 20' Lengths



Schedule 40 Forte-Duct® Conduit Belled End - 20' Lengths

Part No.	Size	Feet per Pack	T Min	OD	E	B	D Min	L Min
A60CA42	2	2,800	.154	2.375	2.393	2.369	3.000	240
A60CE42	2-1/2	1,860	.203	2.875	2.890	2.868	3.250	240
A60DA42	3	1,760	.216	3.500	3.515	3.492	3.750	240
A60EA42	4	1,140	.237	4.500	4.515	4.491	4.500	240
A60FA42	5	760	.258	5.563	5.593	5.553	5.500	240
A60GA42	6	520	.280	6.625	6.658	6.614	6.125	240

Note: 10' length available on request

Dimensions are nominal

DBHM-120 Forte-Duct® Conduit Belled End - 20' Lengths

Part No.	Size	Feet per Pack	T Min	OD	E	B	D Min	L Min
A59EA42	4	1,140	.154	4.500	4.544	4.509	3.375	240
A59GA42	6	520	.227	6.625	6.687	6.636	5.000	240

Dimensions are nominal

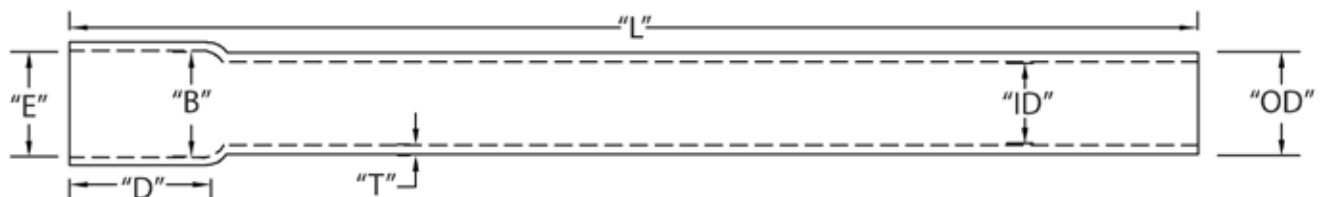

Rigid Nonmetallic Schedule 40 Split Duct and Utility Duct

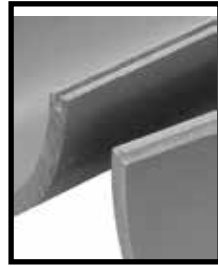

Enables repair of damaged conduit in existing installations with no cutting and splicing of cables.

This product is not UL Listed
Dimensions conform to UL 651 Specification

Schedule 40 Split Duct - 10' Lengths

Part No.	Size	Feet per Pack	OD	ID	Wall Thickness	Length
A52DAZS	3	500	3.500 ± .008	3.008	.216	120
A52EAZS	4	290	4.500 ± .074	3.961	.237	120

Dimensions are nominal

Schedule 40 Split Sleeve Coupling (Fabricated)

Part No.	Size	Package Qty.	"DIA"	"A"
6141684	2	25	2.375	6.125
6141685	3	25	3.500	6.188
6141690	4	15	4.563	6.250
6141692	5	8	5.625	8.875
6141693	6	4	6.563	10.125

Dimensions are nominal



DBHM-60 Split Sleeve Coupling (Fabricated)

Part No.	Size	Package Qty.	"DIA"	"A"
6151783	2	20	2.375	6.063
6151784	3	25	3.500	6.750
6151785	4	15	4.500	6.375
6151786	5	8	5.563	8.750
6151787	6	4	6.625	9.750

Dimensions are nominal

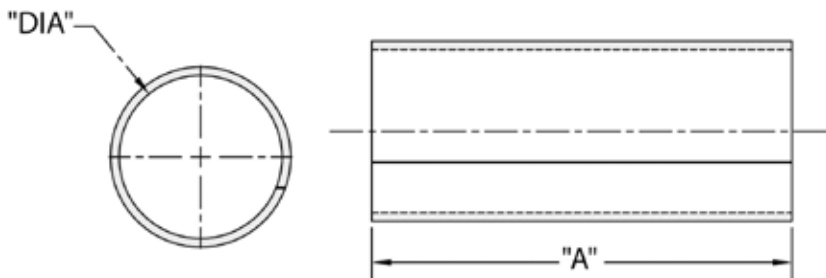

Rigid Nonmetallic PVC Utility Duct 500,000 PSI Modulus

Conforms to NEMA TC6 and ASTM F-512 requirements
 Rated for 90°C Cable
 20' Lengths

Type DBHM-60 (For Direct Burial) - 20' Lengths, Bell End

Part No.	Size	Feet per Pack	"T" Min	"OD"	"E"	"B"	"D" Min.	"L" Min.
A79CA42	2	2,800	.060	2.375	2.400	2.381	1.750	240
A79DA42	3	1,760	.092	3.500	3.538	3.508	2.875	240
A79EA42	4	1,140	.121	4.500	4.544	4.509	3.375	240
A79FA42	5	760	.152	5.563	5.614	5.573	4.000	240
A79GA42	6	520	.182	6.625	6.687	6.636	5.00	240

Dimensions are nominal

Type EBHM-20 (For Encasement Burial) - 20' Lengths, Bell End



Part No.	Size	Feet per Pack	"T" Min	"OD"	"E"	"B"	"D" Min.	"L" Min.
A77CA42	2	2,800	.060	2.387	2.396	2.378	1.750	240
A77DA42	3	1,760	.061	3.500	3.529	3.503	2.875	240
A77EA42	4	1,140	.082	4.500	4.533	4.502	3.375	240
A77FA42	5	760	.103	5.563	5.601	5.562	4.000	240
A77GA42	6	520	.125	6.625	6.669	6.627	5.000	240

Dimensions are nominal

Type EB complies with federal and military specifications by conforming to UL 651

Type DBHM-100 (For Direct Burial) - 20' Lengths, Bell End

Part No.	Size	Feet per Pack	"T" Min	"OD"	"E"	"B"	"D" Min.	"L" Min.
A72DA42	3	1,760	.112	3.500	3.538	3.508	2.875	240
A72EA42	4	1,140	.145	4.500	4.544	4.509	3.375	240
A72FA42	5	760	.179	5.563	5.614	5.573	4.000	240
A72GA42	6	520	.213	6.625	6.687	6.636	5.000	240

Dimensions are nominal

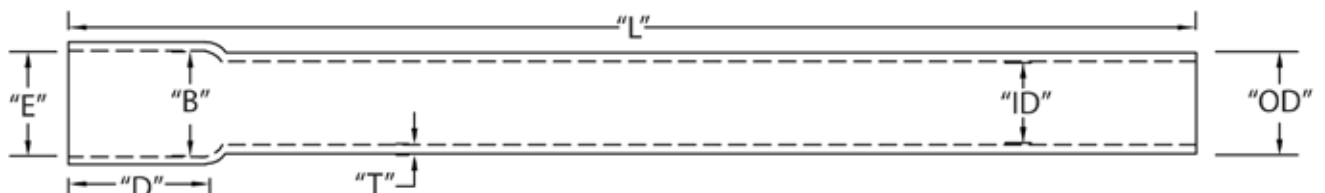

Rigid Nonmetallic Utility Duct

Conforms to NEMA TC8 and ASTM F-512 requirements
 Rated for 90°C Cable
 20' Lengths

Type DBHM-120 (For Direct Burial) - 20' Lengths, Bell End

Part No.	Size	Feet per Pack	"T" Min	"OD"	"E"	"B"	"D" Min.	"L" Min.
A55BA42	1	7,200	.060	1.315	1.331	1.320	1.000	240
A55BE42	1-1/2	4,500	.060	1.900	1.921	1.906	1.375	240
A55CA42	2	2,800	.077	2.375	2.400	2.381	1.750	240
A55DA42	3	1,760	.118	3.500	3.538	3.508	2.875	240
A55EA42	4	1,140	.154	4.500	4.544	4.509	3.375	240
A55FA42	5	760	.191	5.563	5.614	5.573	4.000	240
A55GA42	6	520	.227	6.625	6.687	6.636	5.000	240

Dimensions are nominal

Type EBHM-35 (For Encasement Burial) - 20' Lengths, Bell End

Part No.	Size	Feet per Pack	"T" Min	"OD"	"E"	"B"	"D" Min.	"L" Min.
A57EA42	4	1,140	.082	4.500	4.533	4.502	3.375	240
A57FA42	5	760	.103	5.563	5.601	5.565	4.000	240
A57GA42	6	520	.125	6.625	6.669	6.627	5.000	240

Dimensions are nominal

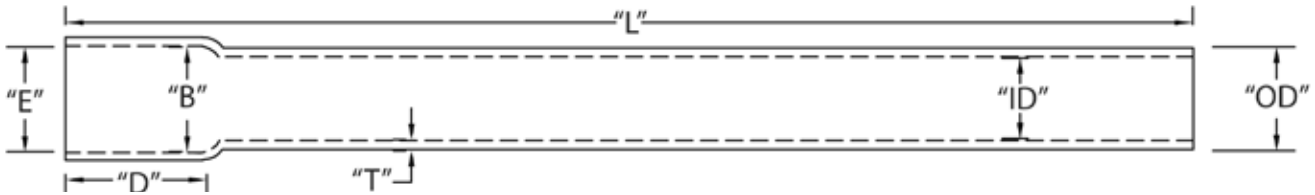

Corrugated Power & Communication Duct

P&C Flexible Utility Duct



Part No.	Size	O.D. (Nom)	I.D. (Nom)	Approx. Wt/Ft	Feet per Spool
A90CAG1	2	2.375	2.045	.260	250
A90DAG1	3	3.500	3.068	.540	250
A90EAG1	4	4.500	4.026	.740	250

Dimensions are nominal

Meets NEMA TC-12 Standards
 For Non-UL Applications
 Uses standard Schedule 40 Fittings

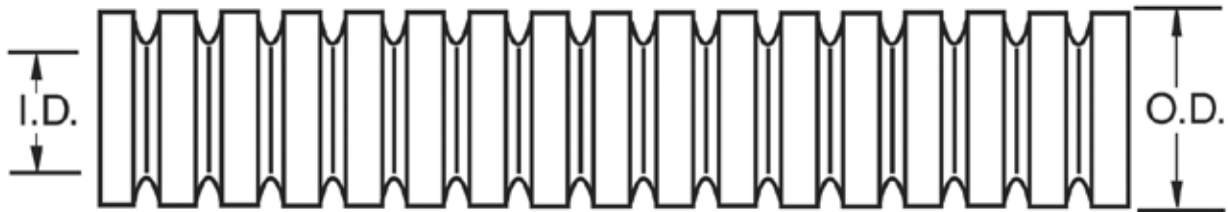

INSTALLATION INSTRUCTIONS

1. Clean both ends of duct to be joined.
2. Trim ends square to ensure a secure joint.
3. Using standard solvent cement, apply a full, even coat of cement to outside of flexible duct to the depth of fitting to be joined to the duct.
4. Apply a light coat of cement to the inside of the fitting.
5. Slide fitting over the end of the duct twisting slightly to be sure fittings fully seated.

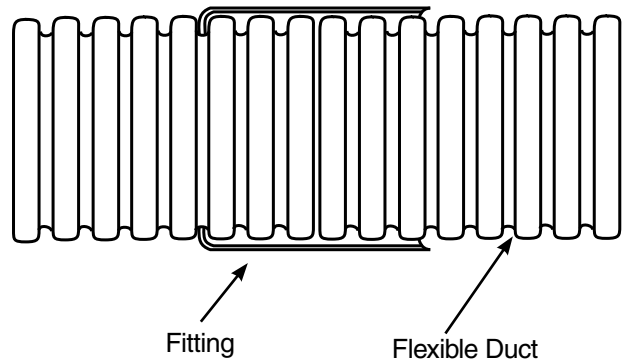

Conduit #99 Low VOC Cement



Part Number	Size	Weight	Carton Qty.
7210601	1/2 Pint	.595	24
7210602	Pint	1.093	12
7210603	Quart	2.110	12
7210605	Gallon	8.207	6



Flexible Electrical Nonmetallic Tubing and Accessories



EZ-Flex® Electrical Nonmetallic Tubing

Meets specifications: NEMA TC-13 and NEC Article 362 and UL 1653
Suitable for use with 90°C conductors.

- **CANTEX EZ-FLEX®** ENT is a high performance lower cost alternative to electrical metallic tubing. Non-conductive and corrosion resistant.
- EZ-FLEX® not only costs less than metal tubing but installation time is dramatically reduced, saving expensive labor cost.
- Corrugated design allows bending by hand, eliminating the necessity of bending equipment and special tools. Reduced inner surface area cuts down on drag so that wire pulling is accomplished easier and faster.
- UL Listed EZ-FLEX® is used in circuits of 600 volts or less. Minimum installation temperature is -4°F (-20°C) and maximum ambient temperature is 122°F (50°C). EZ-FLEX® is made in electric blue color for easy identification.

EZ-FLEX® Straight 10' Lengths



Part No.	Size	Feet per Pack	O.D. (Nom)		I.D. (Nom)		Approx. Wt/Ft
			Min.	Max.	Min.	Max.	
A51AE11	1/2	3,600	.832	.848	.574	.630	.100
A51AG11	3/4	4,000	1.040	1.060	.744	.834	.137
A51BA11	1	2,400	1.305	1.325	.999	1.059	.178

Dimensions are nominal

EZ-FLEX® Coils



Part No.	Size	Feet per Coil	O.D. (Nom)		I.D. (Nom)		Approx. Wt/Ft
			Min.	Max.	Min.	Max.	
A51AEB1	1/2	200	.832	.848	.574	.630	.100
A51AGA1	3/4	100	1.040	1.060	.744	.834	.137
A51BAA1	1	100	1.305	1.325	.999	1.059	.178

Dimensions are nominal

EZ-FLEX® Reels



Part No.	Size	Feet per Pack	O.D. (Nom)		I.D. (Nom)		Approx. Wt/Ft
			Min.	Max.	Min.	Max.	
A51AEQ1	1/2	1,500	.832	.848	.574	.630	.100
A51AEK1	1/2	5,000	.832	.848	.574	.630	.100
A51AGJ1	3/4	1,000	1.040	1.060	.744	.834	.137
A51BAN1	1	750	1.305	1.325	.999	1.059	.178

Dimensions are nominal

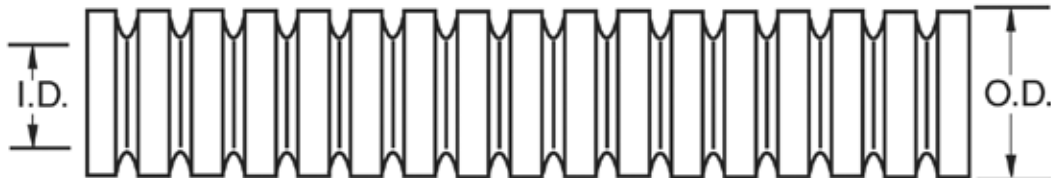

Electrical Nonmetallic Accessories

ENT Coupling



Part No.	Size	Carton Qty.	A	B	C	D
5163380	1/2	200	2.000	.700	.850	1.235
5163381	3/4	200	1.957	.894	1.057	1.529
5163382	1	100	2.127	1.123	1.325	1.793

Dimensions are nominal

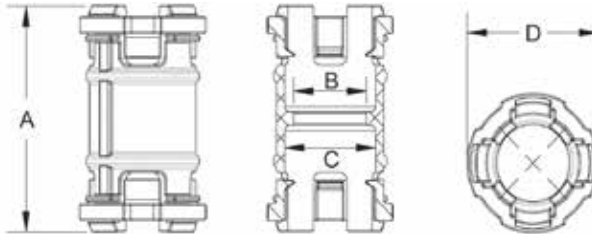

ENT Male Adapter - Threaded



Part No.	Size	Carton Qty.	A	B	C	D
5163415	1/2	200	1.620	14 NPT	.600	1.235
5163416	3/4	200	1.548	14 NPT	.797	1.529
5163417	1	100	1.763	11-1/2 NPT	1.010	1.793

Dimensions are nominal

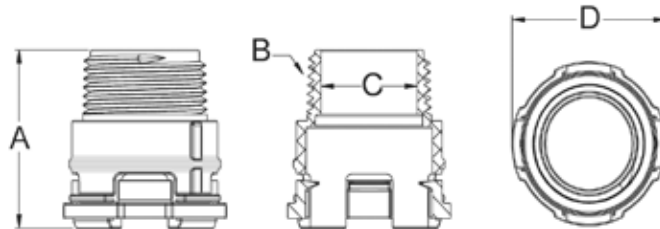

ENT Male Adapter - Snap In



Part No.	Size	Carton Qty.	A	B	C	D
5163405	1/2	200	1.460	.963	.850	1.235
5163406	3/4	200	1.438	1.185	1.057	1.529
5163407	1	100	1.523	1.455	1.325	1.793

Dimensions are nominal

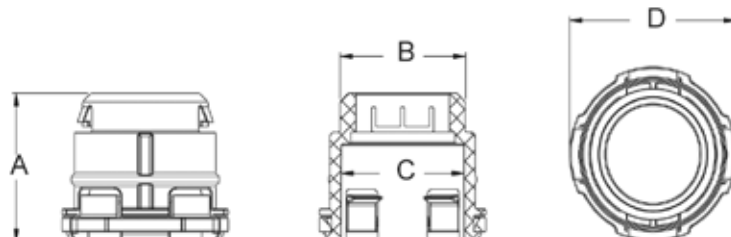

Electrical Nonmetallic Accessories

ENT Slab Box with Knockouts

Part No.	Connectors	Carton Qty.	"A"	"B"	"C"	"D"	"E"	"F"	"G"	"H"	"J"	"H"
ENS0507K	4 x 1/2" - 4 x 3/4"	25	4.530	2.250	4.530	2.250	3.444	1.340	2.125	3.590	1.063	.125
ENS050K	8 x 1/2"	25	4.530	2.250	4.530	2.250	3.444	1.340	2.125	3.590	1.063	.125

Dimensions are nominal

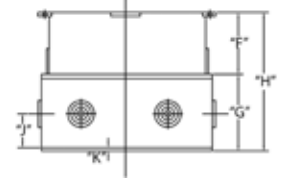
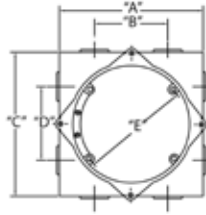
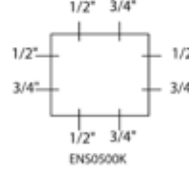
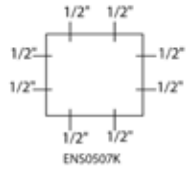

ENT Slab Box with Connectors

Part No.	Connectors	Carton Qty.	"A"	"B"	"C"	"D"	"E"	"F"	"G"	"H"	"J"	"H"
ENS0507C	4 x 1/2" - 4 x 3/4"	25	4.530	2.250	4.530	2.250	3.444	1.340	2.125	3.590	1.063	.125
ENS0500C	8 x 1/2"	25	4.530	2.250	4.530	2.250	3.444	1.340	2.125	3.590	1.063	.125

Dimensions are nominal

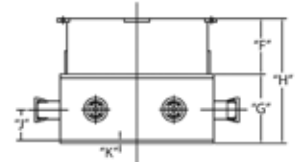
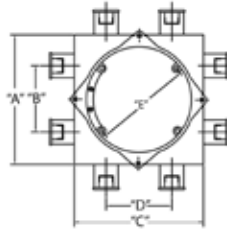
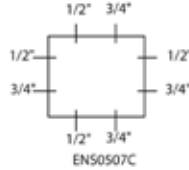
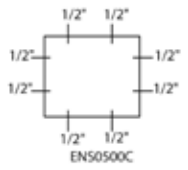

ENT Stubby



Part No.	Size	Carton Qty.
EN050SBY	1/2"	150
EN075SBY	3/4"	150
EN100SBY	1"	200

INSTALLATION INSTRUCTION - ELECTRICAL NONMETALLIC TUBING

Instructions for Solvent Welding Fittings to Electrical Nonmetallic Tubing (ENT)

- 1) Use **CANTEX** No. 50 ENT Solvent Cement or other PVC cement which is specifically labeled for use with ENT. **DO NOT USE** heavy or medium bodied PVC cement (pressure pipe type) or combination ABS/PVC cement.
- 2) Cut tubing ends square and smooth with a knife or saw. Remove burrs and ragged edges with a knife, file or abrasive cloth.
- 3) Remove all dust, dirt and moisture from ENT and fittings before applying cement.
- 4) **DO NOT USE PRIMER OR CLEANER.**
- 5) Apply **CANTEX** No. 50 Solvent Cement with the natural bristle brush supplied in the can lid. **DO NOT USE A DAUBER.**
- 6) Apply a light, uniform coat of cement inside the socket fitting.
- 7) Apply a light, uniform coat of cement to the outside surface of the ENT to the depth of the fitting socket. Brush **AROUND THE CORRUGATIONS OF THE ENT, NOT LONGITUDINALLY.** Brush away any excess cement out of the grooves of the ENT. Excess cement may cause burning and excess softening of the ENT which may result in joint failure under stress.
- 8) While cement is still set, quickly insert the ENT up to the center stop of the fitting. Give the fitting a quarter turn and hold firmly in place for 15 to 30 seconds. Do not disturb the fitting for two to five minutes to allow firm joint set.

Helpful Tips for Better Joints

The best solvent cementing results are obtained in temperatures above 40°F. In colder temperatures, allow longer times for initial settings. In cold weather, do not put joints under stress for 24 to 48 hours.

Keep can lid closed while not in use since cement is highly volatile and also will absorb moisture from the air. Do not use cement if it becomes lumpy or jelled. If lumpy or jelled, **DISCARD THE PVC CEMENT** and do not try to thin with PVC primer or cleaner.

Installers should verify for themselves that they can make satisfactory joints under varying conditions. Contact **CANTEX** for additional instructions or information if needed.

Do not use PVC solvent cement on the threads of threaded fittings.

CAUTION

PVC Cement is highly flammable. Do not use in the presence of lighted smoking materials, open flames, metal welding in progress or open electrical arcs.

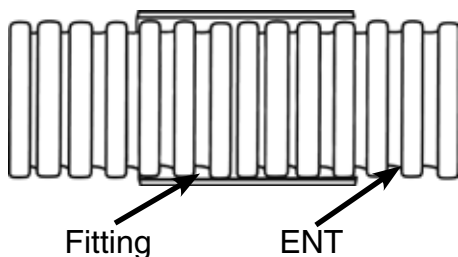

Conduit Cement ENT No. 50 Low VOC

Part No.	Size	Std. Pkg.	UPC-ITF 3 00 88700	Pkg. Wt.
7210402	Pint	12	01020 9	13.12
7210403	Quart	12	01021 6	13.12

Enviro-Flex® Liquidtight Flexible Conduit & Fittings



Enviro-Flex® Liquid Tight Conduit

Liquid Tight Nonmetallic Flexible Conduit Conforms to NEC Article 356 and UL 1660

Enviro-Flex® gives complete environmental protection for exposed cable installations and is ideal for use with control and motor applications, machinery tools, moving machinery, console wire, transformer connections, outdoor lighting, air conditioning, heating systems and computer power distribution.

Enviro-Flex® offers advantages compared to metal conduit.

- **INSTALLATION**

Enviro-Flex® costs less to install. It is easy to cut with no jagged edges, is less than half the weight of metal and can utilize all existing liquid tight fittings.

- **FLEXIBILITY**

Enviro-Flex® is more flexible and its smooth inner bore makes pulling wires easier than ever.

- **SERVICE ENVIRONMENT**

Enviro-Flex® is waterproof, acid, oil, alkaline and corrosion resistant. It is non-conductive, self-extinguishing and extremely resistant to crush, abrasion and strain. UL listed for constant use at maximum 60°C (140°F) and for sunlight resistance.



Enviro-Flex® Liquid Tight Conduit - Coils

Part No.	Size	Feet per Coil	O.D. (Nom)		I.D. (Nom)		Approx. Wt/Ft
			Min.	Max.	Min.	Max.	
V06ADA1	3/8	100	.690	.710	.484	.504	.128
V06AEA1	1/2	100	.820	.840	.622	.642	.136
V06AGA1	3/4	100	1.030	1.050	.820	.840	.165
V06BAA1	1	100	1.290	1.315	1.041	1.066	.259
V06BCN1	1-1/4	50	1.630	1.660	1.380	1.410	.339
V06BEN1	1-1/2	50	1.865	1.900	1.575	1.60	.446
V06CAN1	2	50	2.340	2.375	2.020	2.045	.617

Dimensions are nominal

Enviro-Flex® Liquid Tight Conduit - Reels

Part No.	Size	Feet per Reel	O.D. (Nom)		I.D. (Nom)		Approx. Wt/Ft
			Min.	Max.	Min.	Max.	
V06AEJ1	1/2	1000	.820	.840	.622	.642	.136
V06AGM1	3/4	700	1.030	1.050	.820	.840	.165
V06BAD1	1	400	1.290	1.315	1.041	1.066	.259

Dimensions are nominal

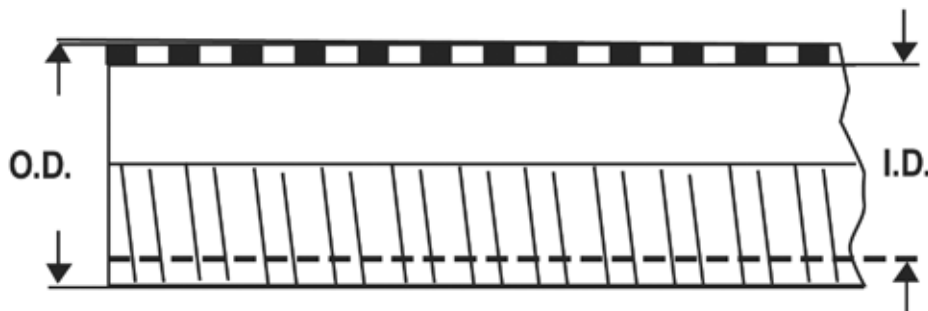

Enviro-Flex® Liquid Tight Conduit Fittings

Enviro-Flex® Straight Connectors



Part No.	Size	Carton Qty.	A	B	C
6441000	3/8	100	2.000	.540	1.400
6441001	1/2	100	2.000	.540	1.400
6441002	3/4	50	2.200	.635	1.700
6441003	1	25	2.280	.740	2.000
6441004	1-1/4	25	2.440	.760	2.400
6441005	1-1/2	10	2.700	.800	2.670
6441006	2	10	2.990	.850	3.280

Dimensions are nominal

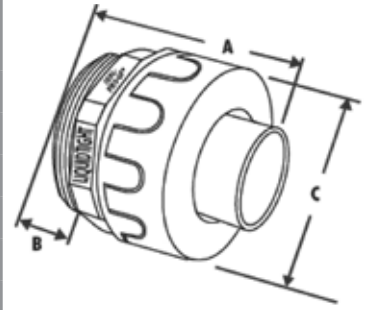

Enviro-Flex® 90° Connectors



Part No.	Size	Carton Qty.	A	B	C
5441000	3/8	50	2.120	.500	3.120
5441001	1/2	50	2.120	.500	3.120
5441002	3/4	50	2.500	.520	3.600
5441003	1	25	3.125	.700	4.125
5441004	1-1/4	25	4.450	.760	5.200
5441005	1-1/2	10	4.750	.800	5.200
5441006	2	10	5.420	.860	5.800

Dimensions are nominal

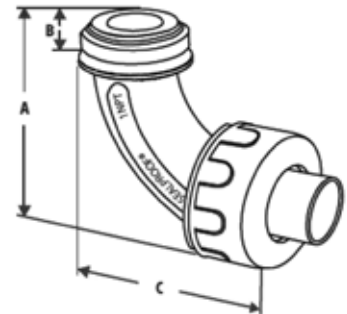

Enviro-Flex® Flexible Elbows



Part No.	Size	Carton Qty.
6441101	1/2	8
6441102	3/4	6
6441103	1	6

Applications:

- HVAC equipment
- Machine tools
- Marine equipment
- Motors and controls
- Printing equipment
- Pumps
- Refrigeration equipment
- Assemblies
- Wire hook-up

Enviro-Flex® Kits



Part No.	Size	Carton Qty.
5441051	1/2	4
5441052	3/4	4

Directional Drilling Conduit



Directional Drilling Conduit

Schedule 40 CAN>LOC™ Conduit - 20 Lengths

Schedule 40 designed for directional drilling applications of up to 1,000 feet.

No solvent cement needed for secure, water-proof joints.



 Conforms to UL 651 and NEMA TC-2

Part Number	Trade Size	Length	Lay Length	Conduit O.D. (In.)	Conduit I.D. (In.)	Bell O.D. (In.)	Pack Qty.	Feet per Truckload	Wt. per 100 ft. (Lbs.)	Min. Bend Radius (ft.)	Insertion Force (Lbs.)	Seal Pressure Rating (Lbs.)	Joined Pull Rating (Lbs.)	Typical Crush (Lbs. @ 30% deflection)	UL 651 / NEMA TC2 Min. Crush (Lbs)
A24EA42	4	20	19.5	4.5	4.0	5.7	520	14,560'	234	65	70	75	12,000	1,075	900
A24GA42	6	20	19.5	6.6	6.0	8.0	400	8,000	456	65	80	75	18,000	950	850

Part Number	Size	Description	T Min	OD	ID Min	E	D Min	L Min
A24EA42	4	CAN>LOC™	.237	4.500	3.961	4.515	6.000	240
A24GA42	6	CAN>LOC™	.280	6.625	5.986	6.658	7.000	240

Dimensions are nominal

Schedule 40 CAN>GRIP™ Conduit - 20 Lengths

The easy assembly method takes out the human error involved in the installation of external joint restraints. CAN>GRIP™ offers a quick joining method by simply pushing the spigot into the bell end of the adjoining pipe that is equipped with the new CAN>GRIP™ joint restraint. Once the pipe is installed, the gripper ring self engages the spigot thus locking the joint. The unique bell contains a gasket to maintain a watertight system.



 Conforms to UL 651 and NEMA TC-2

Part Number	Trade Size	Length	Lay Length	Conduit O.D. (In.)	Conduit I.D. (In.)	Bell O.D. (In.)	Pack Qty.	Feet per Truckload	Wt. per 100 ft. (Lbs.)	Min. Bend Radius (ft.)	Insertion Force (Lbs.)	Seal Pressure Rating (Lbs.)	Joined Pull Rating (Lbs.)	Typical Crush (Lbs. @ 30% deflection)	UL 651 / NEMA TC2 Min. Crush (Lbs)
A30EA42	4	20	19.5	4.5	4.0	5.7	520	14,560	234	65	70	75	10,000	1,075	900
A30GA42	6	20	19.5	6.6	6.0	8.0	400	8,000	456	65	100	75	14,000	950	850

Part Number	Size	Description	T Min	OD	ID Min	E	D Min	L Min
A30EA42	4	CAN>GRIP™	.237	4.500	3.961	4.515	6.000	240
A30GA42	6	CAN>GRIP™	.280	6.625	5.986	6.658	7.000	240

Dimensions are nominal

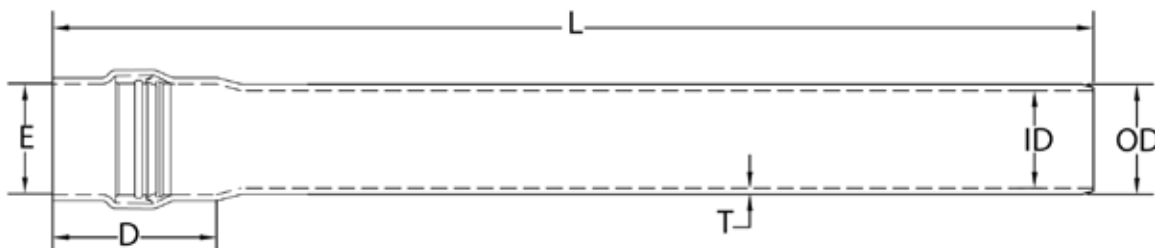

Telephone Duct Fittings & Accessories



Telephone Duct

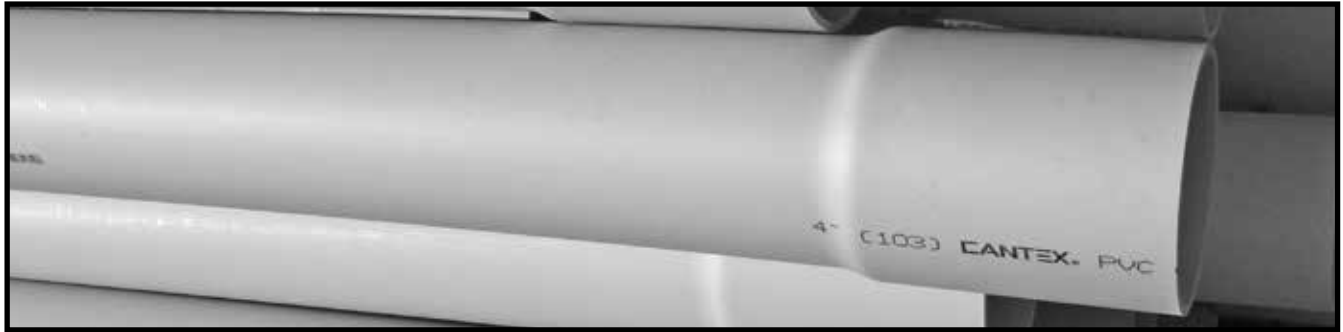

CAO Telephone Duct - Type C Conforms to NEMA TC-10

CANTEX Part No.	Size	Approx. Wt/Ft	Feet per Pack	OD (Min)	ID (Min)	T (Min)	B (Min)	D (Min)	E (Min)	L (Min)
A93EA42	4	1.468	1,260	4.345	3.930	.150	4.350	6.000	4.375	243

Type C Duct can also be used for concrete encased applications where specified.

Dimensions are nominal

Type DBHM-120 (For Direct Burial) 500,000 PSI Modulus

CANTEX Part No.	Size	Approx. Wt/Ft	Feet per Pack	OD (Min)	ID (Min)	T (Min)	B (Min)	D (Min)	E (Min)	L (Min)
A55CA42	2	.420	2,800	2.375	2.221	.077	2.381	1.750	2.400	240
A55DA42	3	.947	1,760	3.500	3.264	.118	3.538	2.875	3.538	240
A55EA42	4	1.589	1,140	4.500	4.192	.154	4.509	3.375	4.553	240

Dimensions are nominal

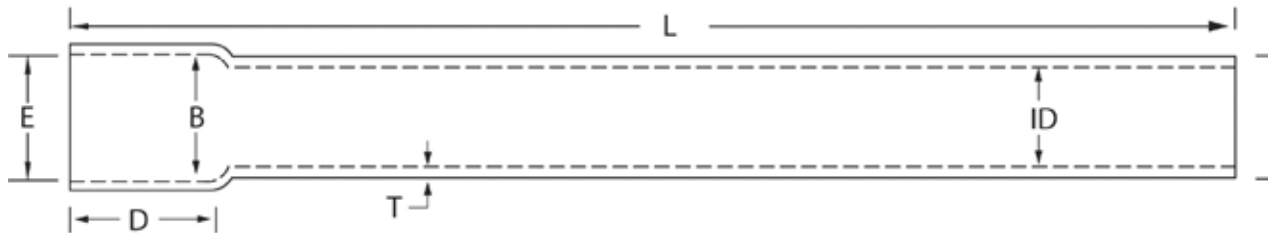

Rigid Nonmetallic Schedule 40 Conduit



Meets specifications of UL 651 and NEMA TC2
 Rated for 90°C Cable
 Sunlight Resistant
 10' Lengths



Schedule 40 Conduit Belled End - 10' Lengths

Part No.	Size	Feet per Pack	T Min	OD	ID Min	E	B	D Nom	L Min
A52AE12	1/2	6,000	.109	.840	.578	.852	.836	1.500	120
A52AG12	3/4	4,400	.113	1.050	.780	1.064	1.046	1.750	120
A52BA12	1	3,600	.133	1.315	1.004	1.330	1.310	2.000	120
A52BC12	1-1/4	3,300	.140	1.660	1.335	1.677	1.655	2.250	120
A52BE12	1-1/2	2,250	.145	1.900	1.564	1.918	1.894	2.500	120
A52CA12	2	1,400	.154	2.375	2.021	2.393	2.369	3.000	120
A52CE12	2-1/2	930	.203	2.875	2.414	2.890	2.868	3.250	120
A52DA12	3	880	.216	3.500	3.008	3.515	3.492	3.750	120
A52DE12	3-1/2	630	.226	4.000	3.486	4.015	3.992	4.000	120
A52EA12	4	570	.237	4.500	3.961	4.515	4.491	4.500	120
A52FA12	5	380	.258	5.563	4.975	5.593	5.553	5.500	120
A52GA12	6	260	.280	6.625	5.986	6.658	6.614	6.125	120

Dimensions are nominal

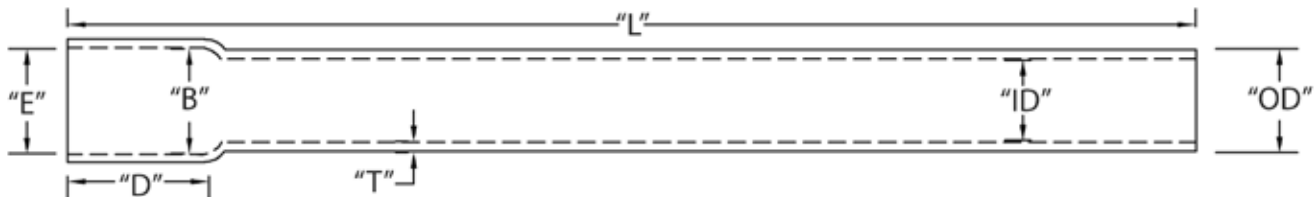

Note: 20' length available on request

Schedule 40 conduit complies with federal and military specifications by conforming to UL 651

Rigid Nonmetallic Schedule 80 Conduit

Meets specifications of UL 651 and NEMA TC2
 Rated for 90°C Cable
 Sunlight Resistant
 10' Lengths



Nonmetallic PVC Schedule 80 Conduit Belled End - 10' Lengths

Part No.	Size	Feet per Pack	T Min	OD	ID Min	E	B	D Nom	L Min
A53AE12	1/2	6,000	.147	.840	.502	.852	.836	1.500	120
A53AG12	3/4	4,400	.154	1.050	.698	1.064	1.046	1.750	120
A53BA12	1	3,600	.179	1.315	.910	1.330	1.310	2.000	120
A53BC12	1-1/4	3,300	.191	1.660	1.227	1.677	1.655	2.250	120
A53BE12	1-1/2	2,250	.200	1.900	1.446	1.918	1.894	2.500	120
A53CA12	2	1,400	.218	2.375	1.881	2.393	2.369	3.000	120
A53CE12	2-1/2	930	.276	2.875	2.250	2.890	2.868	3.250	120
A53DA12	3	880	.300	3.500	2.820	3.515	3.492	3.750	120
A53EA12	4	570	.337	4.500	3.737	4.515	4.491	4.500	120
A53FA12	5	380	.375	5.563	4.713	5.593	5.553	5.500	120
A53GA12	6	260	.432	6.625	5.646	6.658	6.614	6.125	120

Dimensions are nominal

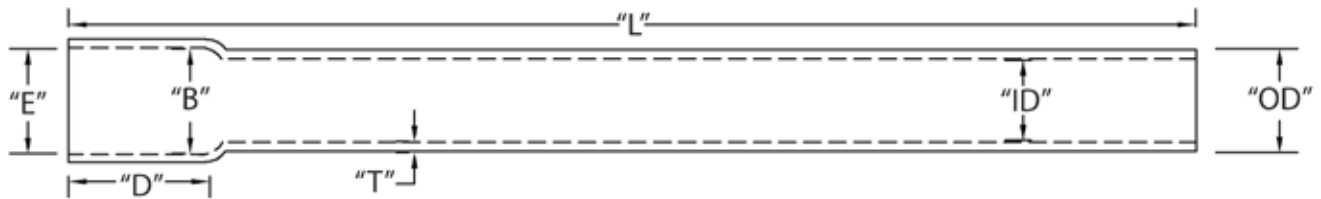

Note: 20' length available on request
 Schedule 80 conduit complies with federal and military specifications by conforming to UL 651

Schedule 40 and Type C Telephone Split Duct



Enables repair of damaged conduit in existing installations with no cutting and splicing of cables.

This product is not UL Listed
Dimensions conform to UL 651 Specification

Schedule 40 Split Duct - 10' Lengths

Part No.	Size	Feet per Pack	A Min	B Min	C Min	D Min	E Min	F Min	G Min
A52CAZS	2	700	2.375	2.021	.154	.125	.071	.125	.060
A52DAZS	3	500	3.500	3.008	.216	.125	.080	.125	.074
A52EAZS	4	290	4.500	3.961	.237	.125	.080	.125	.074

Dimensions are nominal

Type C Telephone Split Duct - 10' Lengths

Part No.	Size	Feet per Pack	A Min	B Min	C Min	D Min	E Min	F Min	G Min
A94EAZS	4	320	4.350	3.990	.150	.125	.071	.125	.060

Dimensions are nominal

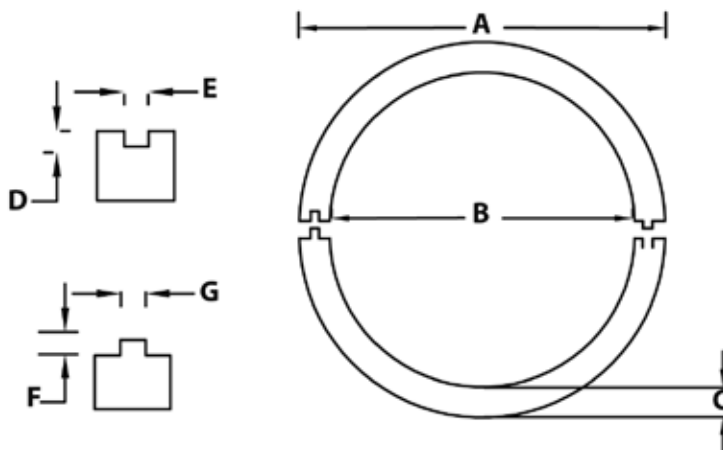

Directional Drilling Conduit

Schedule 40 CAN>LOC™ Conduit - 20 Lengths

Schedule 40 designed for directional drilling applications of up to 1,000 feet.

No solvent cement needed for secure, water-proof joints.



Conforms to UL 651 and NEMA TC-2



Part Number	Trade Size	Length	Lay Length	Conduit O.D. (In.)	Conduit I.D. (In.)	Bell O.D. (In.)	Pack Qty.	Feet per Truckload	Wt. per 100 ft. (Lbs.)	Min. Bend Radius (ft.)	Insertion Force (Lbs.)	Seal Pressure Rating (Lbs.)	Joined Pull Rating (Lbs.)	Typical Crush (Lbs. @ 30% deflection)	UL 651 / NEMA TC2 Min. Crush (Lbs)
A24EA42	4	20	19.5	4.5	4.0	5.7	520	14,560'	234	65	70	75	12,000	1,075	900
A24GA42	6	20	19.5	6.6	6.0	8.0	400	8,000	456	65	80	75	18,000	950	850

Part Number	Size	Description	T Min	OD	ID Min	E	D Min	L Min
A24EA42	4	CAN>LOC™	.237	4.500	3.961	4.515	6.000	240
A24GA42	6	CAN>LOC™	.280	6.625	5.986	6.658	7.000	240

Dimensions are nominal

Schedule 40 CAN>GRIP™ Conduit - 20 Lengths

The easy assembly method takes out the human error involved in the installation of external joint restraints. CAN>GRIP™ offers a quick joining method by simply pushing the spigot into the bell end of the adjoining pipe that is equipped with the new CAN>GRIP™ joint restraint. Once the pipe is installed, the gripper ring self engages the spigot thus locking the joint. The unique bell contains a gasket to maintain a watertight system.



Conforms to UL 651 and NEMA TC-2

Part Number	Trade Size	Length	Lay Length	Conduit O.D. (In.)	Conduit I.D. (In.)	Bell O.D. (In.)	Pack Qty.	Feet per Truckload	Wt. per 100 ft. (Lbs.)	Min. Bend Radius (ft.)	Insertion Force (Lbs.)	Seal Pressure Rating (Lbs.)	Joined Pull Rating (Lbs.)	Typical Crush (Lbs. @ 30% deflection)	UL 651 / NEMA TC2 Min. Crush (Lbs)
A30EA42	4	20	19.5	4.5	4.0	5.7	520	14,560	234	65	70	75	10,000	1,075	900
A30GA42	6	20	19.5	6.6	6.0	8.0	400	8,000	456	65	100	75	14,000	950	850

Part Number	Size	Description	T Min	OD	ID Min	E	D Min	L Min
A30EA42	4	CAN>GRIP™	.237	4.500	3.961	4.515	6.000	240
A30GA42	6	CAN>GRIP™	.280	6.625	5.986	6.658	7.000	240

Dimensions are nominal

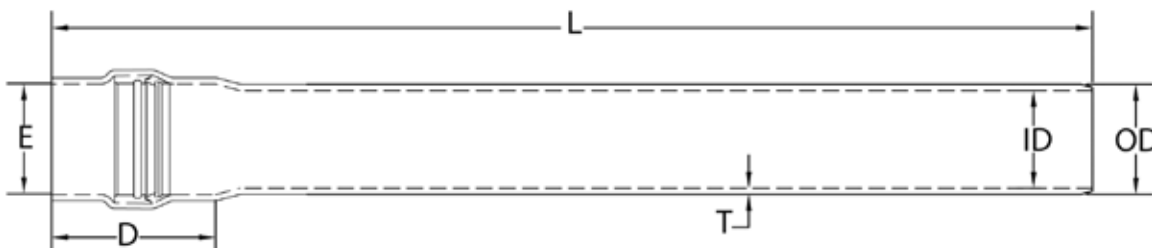

Telephone Duct - Fittings & Accessories

Adapts 4" Threaded Metal Pipe to 4" Telephone Duct

Part No.	Size	Approx. Wt.	Carton Qty.	"A"	"B"	"C"	"D"	"L"	"W"
5164037S	3-1/2"x 4	.800	10	3.000	4.000	4.313	4.375	16.000	4.000

Dimensions are nominal

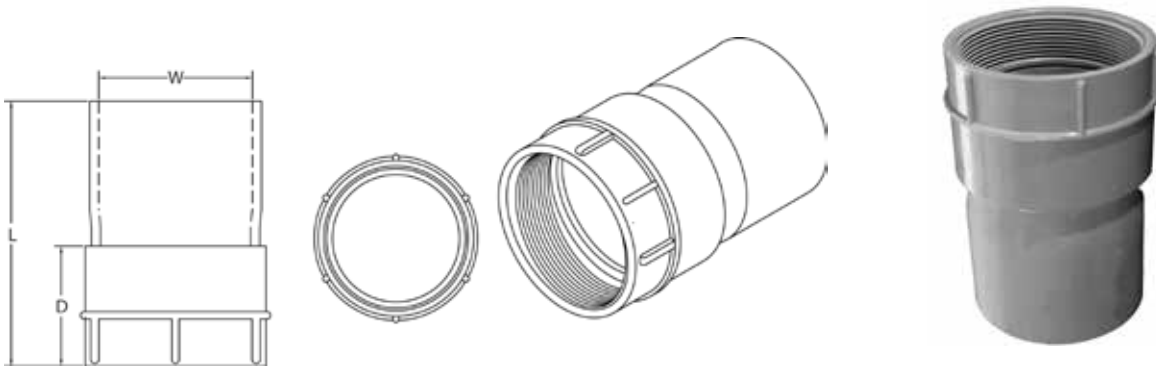

Adapts 4" Telephone Duct to Square Clay Tile

Part No.	Size	Approx. Wt.	Carton Qty.	"L"	"W"	"A"	"B"	"D"	"E" (Min.)	"F" (Max.)
5164036	3-1/4 x 4	.800	24	8.000	4.938	2.500	4.000	4.625	3.000	3.380
5164037	3-1/2 x 4	.800	10	8.000	4.938	2.500	4.000	4.625	3.650	3.250

Dimensions are nominal

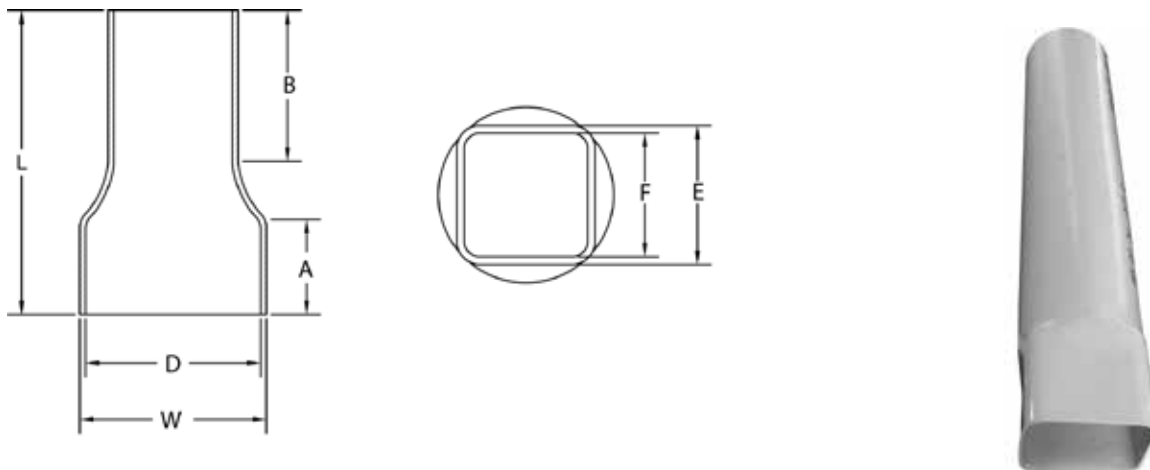

Telephone Duct - Fittings & Accessories

Adapts 4" Telephone Duct to 3-1/4" Round Clay Tile

Part No.	Size	Approx. Wt.	Carton Qty.	"W"	"L"	"B"	"D"	"E"	"R"	"T"
5164031S	4 x 3-1/4 x 18	.800	20	4.625	18.000	2.188	3.500	4.375	3.813	3.250

Dimensions are nominal

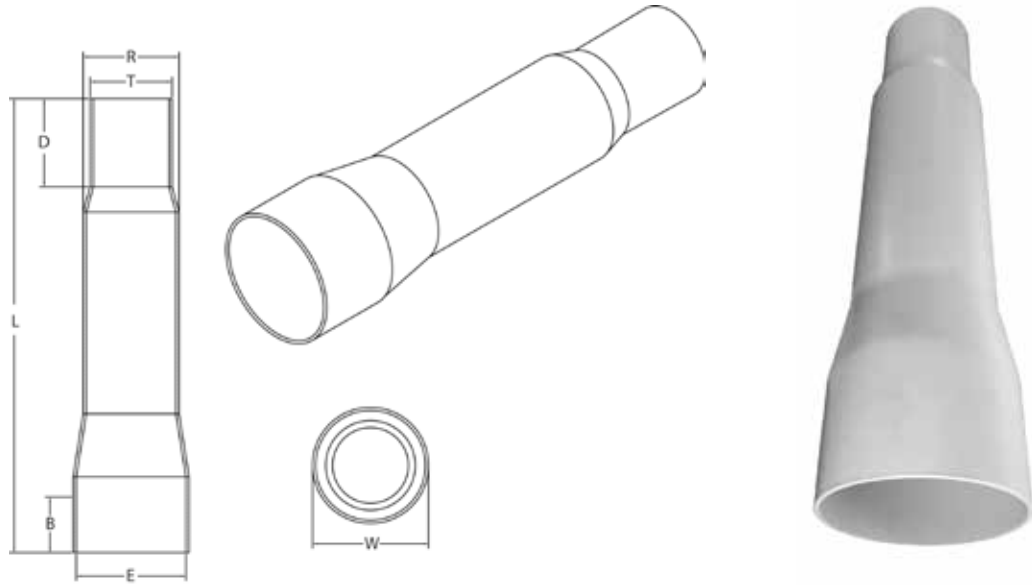

Adapts 4" Telephone Duct to Split 3-1/2" Square Clay Tile

Part No.	Size	Approx. Wt.	Carton Qty.	"W"	"L"	"B"	"D"	"E"	"R"
5164029S	4 x 3-1/2 x 18	.800	8	4.375	18.000	3.000	3.000	4.375	3.750

Dimensions are nominal

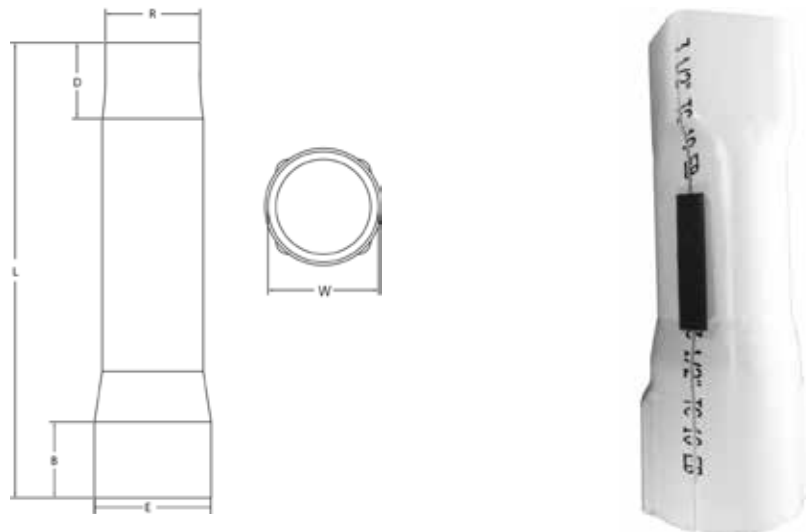

Telephone Duct - Fittings & Accessories

Schedule 40 Conduit Coupling with Center Stop (For Use with Schedule 40 & Schedule 80 conduit)

Part Number	Trade Size	Carton Qty.	"W"	"L"	"ID"	"D"
6141623	1/2	200	1.063	1.500	.875	.625
6141624	3/4	125	1.313	1.563	1.063	.625
6141625	1	70	1.625	2.000	1.313	1.000
6141626	1-1/4	40	2.000	2.125	1.688	1.000
6141627	1-1/2	30	2.250	2.375	1.938	1.063
6141628	2	40	2.688	2.438	2.375	1.250
6141629	2-1/2	20	3.250	3.500	2.875	1.750
6141630	3	40	4.000	3.875	3.500	1.188
6141631	3-1/2	30	4.1250	4.000	4.000	1.938
6141632	4	20	5.000	4.188	4.500	2.000
6141633	5	10	6.125	5.375	5.625	2.500
6141634	6	8	7.250	6.375	6.625	3.000

Dimensions are nominal



A connector used to join lengths of conduit pipe. The fitting consists of two solvent weld female ends with a center stop. Both pieces of pipe should seat at the stop for proper positioning.

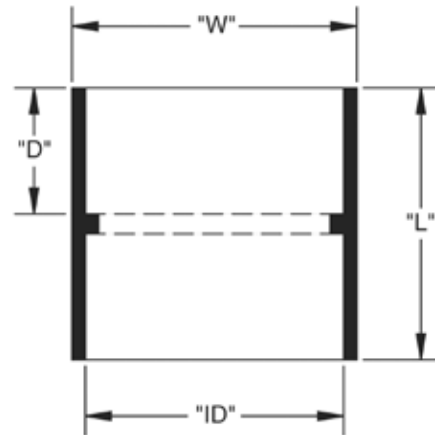

Schedule 40 Longline Conduit Coupling with Center Stop - Molded (For Use with Schedule 40 & Schedule 80 conduit)

Part Number	Trade Size	Carton Qty.	"DIA"	"A"	"B"
6202000	2	20	2.375	4.188	2.000
6202002	2-1/2	25	2.875	6.313	2.750
6202005	3	25	3.500	6.500	3.250
6202010	4	15	4.500	7.000	3.500
6202015	5	8	5.563	8.313	3.625
6202016	6	4	6.625	9.000	3.500

Dimensions are nominal

Molded repair coupling with center stop.
Material is rigid PVC.

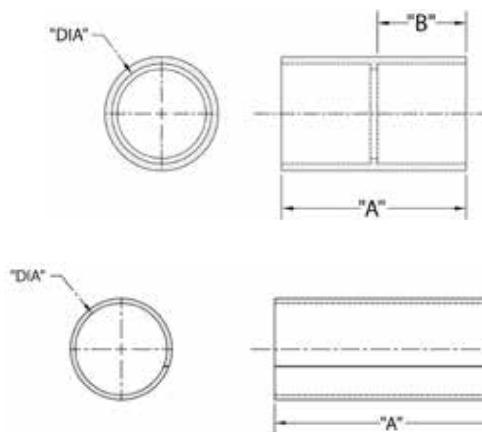

Molded



Sizes 2", 2-1/2", 3" & 4"

Fabricated



Sizes 5" & 6"

Telephone Duct - Fittings & Accessories

Schedule 40 Longline Conduit Coupling with No Center Stop - Fabricated (For Use with Schedule 40 & Schedule 80 conduit)

Part Number	Trade Size	Carton Qty.	"DIA"	"A"
6141702	1	20	1.313	4.500
6141703	1-1/2	20	1.875	4.875
6203000	2	20	2.375	6.063
6203002	2-1/2	20	2.875	6.000
6203005	3	25	3.563	6.750
6203006	3-1/2	25	4.000	6.375
6203007	4	15	4.500	6.375
6203009	5	8	5.688	8.750
6203010	6	4	6.688	9.750

Dimensions are nominal

Fabricated repair coupling with no center stop. Material is rigid PVC.

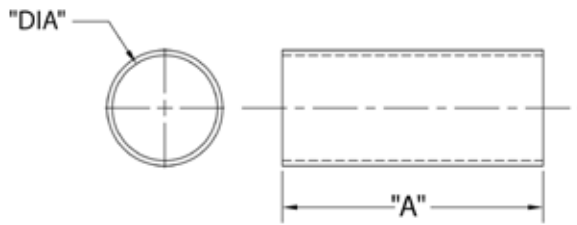

DBHM-120 Coupling

Bell x Bell - Fabricated

Part Number	Size	Carton Qty.	"A"	"B"	"C"	"D"	"L"
6161635	2	35	.075	.094	2.490	2.734	6.000

Dimensions are nominal

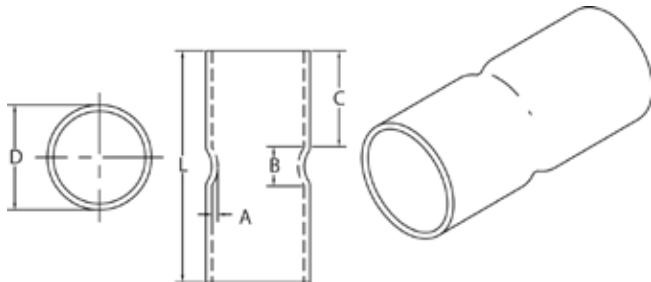

CAO Internal Coupling

Part No.	Size	Approx. Wt.	Carton Qty.	"A"	"B"	"D"
6161633	4	2.000	1	2.5000	4.000	3.750

Dimensions are nominal

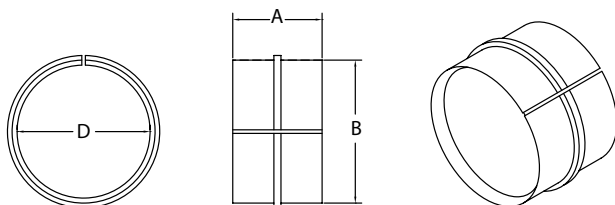

Telephone Duct - Fittings & Accessories

CAO Coupling (Gray) No Center Stop - Fabricated

Part No.	Size	Approx. Wt.	Carton Qty.	"L"	"D"	"T"
6161652	4	.825	50	6.000	4.385	.090

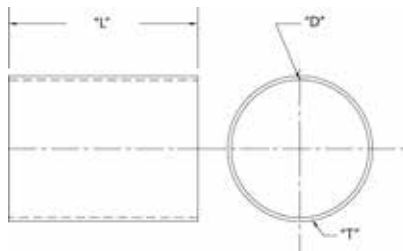

Dimensions are nominal

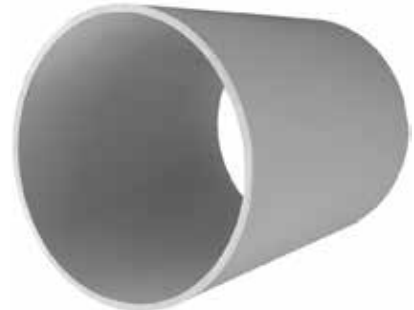

CAO Coupling Center Stop - Fabricated

Part No.	Size	Approx. Wt.	Carton Qty.	"A"	"B"	"C"	"D"
6161632	4	.825	50	3.850	4.350	7.500	.090

Dimensions are nominal

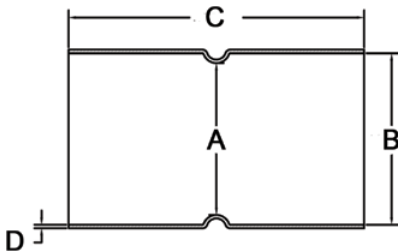

CAO Expansion Coupling for use with Type D Duct

Part No.	Size	Approx. Wt.	Carton Qty.	Collapsed "L"	Extended "L"	"A"	"B"	"C"	"D"	"E"	"F"
6161634	4	.835	25	17.10	25.10	4.64	4.36	3.00	4.64	4.36	3.00

Dimensions are nominal

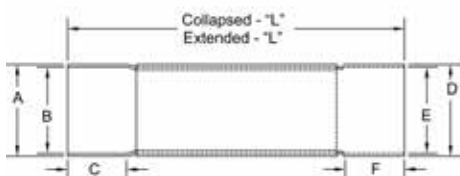

Telephone Duct - Fittings & Accessories

CAO 5° Coupling - Bell to Spigot

Part Number	Size	Carton Qty.	"A"	"B"	"C"	"D"
6161642	2	15	7.000	6.750	4.350	4.380

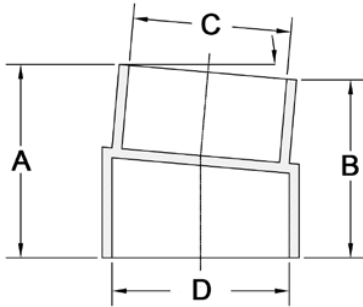

CAO End Bell

Part Number	Size	Carton Qty.	"A"	"B"	"C"	"D"	"E"	"F"
5164015	4 x 6	50	4.380	4.355	3.125	6.000	4.350	5.100

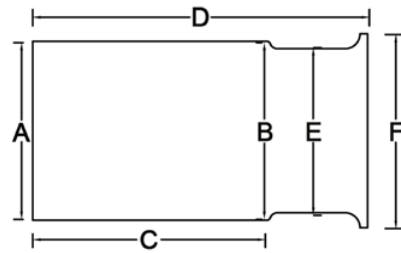

IPS Bell to CAO Spigot Adapter

Part Number	Size	Carton Qty.	"A"	"B"	"C"	"D"	"E"
5163552	4.5 to 4.35	10	4.350	4.515	10.000	2.750	4.491

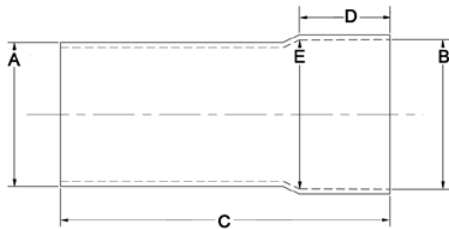

IPS Spigot to CAO Bell Adapter

Part Number	Size	Carton Qty.	"A"	"B"	"C"	"D"	"E"
5163551	4.5 to 4.35	10	4.500	4.380	5.000	3.125	4.355

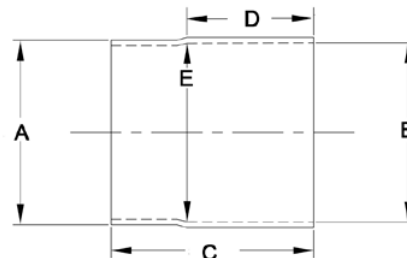

IPS Bell to CAO Bell Adapter

Part Number	Size	Carton Qty.	"A"	"B"	"C"	"D"	"E"	"F"
5163550	4.5 to 4.35	50	4.500	4.380	7.250	3.125	3.125	4.355

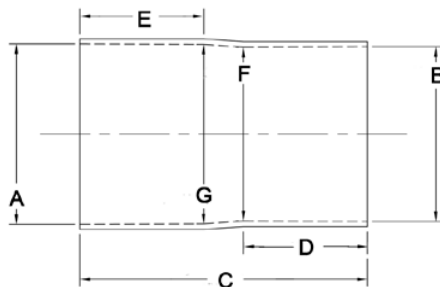

Telephone Duct - Fittings & Accessories

End Cap

Part Number	Trade Size	Carton Qty.	"A"	"B"
5140037	2	50	2.375	1.625
5140039	3	25	3.563	2.375
5140040	4	25	4.500	2.375

Dimensions are nominal

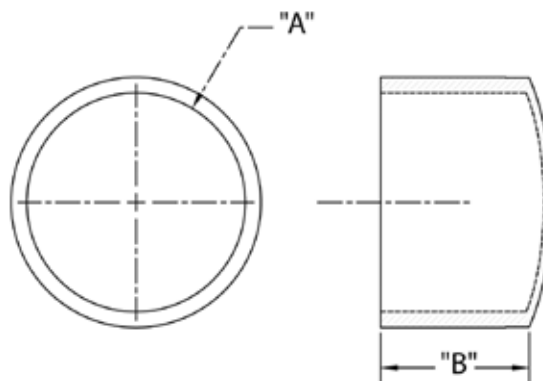

Meets NEMA TC3 Requirements
Made of Rigid PVC

Poly Plug with Pulling Eye

Part Number	Trade Size	Carton Qty.	"L"	"D-1"	"D-2"
5315258	2	70	3.000	2.000	2.500
5315260	3	45	3.750	2.875	3.500
5315262	4	80	3.875	3.750	4.500

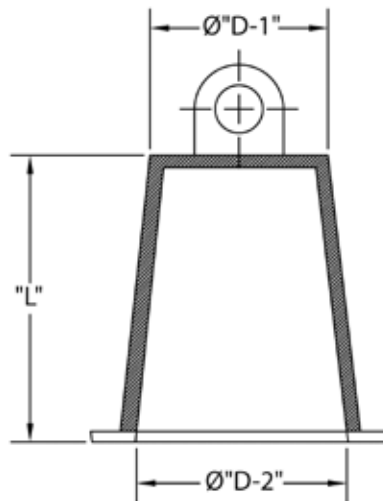

Nonmetallic Conduit Clamp

Part Number	Trade Size	Carton Qty.	"W"	"L"	"H"
5133735	2	200	3.313	4.000	2.563
5133740	3	100	5.125	6.000	3.563
5133353	4	100	6.000	7.000	4.625

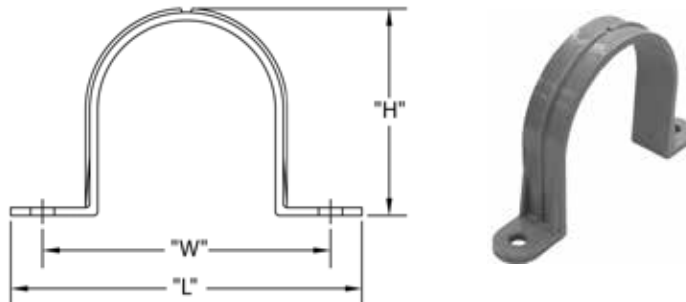

Telephone Duct - Fittings & Accessories

Standard Riser - 10' Lengths

Part No.	Size	Approx. Wt.	Feet per Pack
A23BA12	1	.316	100
A23CA12	2	.619	50
A23DA12	3	1.435	50
A23EA12	4	2.045	50

Schedule 40 Riser - 10' Lengths

CANTEX Part No.	Size	Approx. Wt.	Feet per Pack
A25CA12	2	1.401	50

Wye Branch Adapter (White)

Part No.	Size	Approx. Wt.	Carton Qty.
5163556S	4	4.000	12



Schedule 40 & Schedule 80 90° Special Radius Elbows Bell End

Schedule 40 90° Elbow Special Radius - Bell End

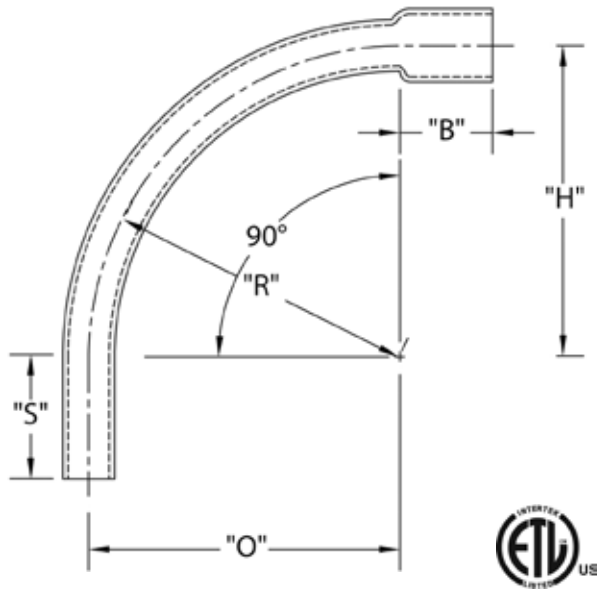

Schedule 40 90° Elbow 24" Radius Bell End

Part Number	Trade Size	"R"	"O"	"H"	"S" MIN	"B" MIN	"L"
5133924	2	24.000	24.000	24.000	2.000	2.000	37.688
5233837	3	24.000	24.000	24.000	3.125	2.500	37.688
5233822	4	24.000	24.000	24.000	3.375	3.250	37.688

Dimensions are nominal

Schedule 40 90° Elbow 36" Radius Bell End

Part Number	Trade Size	"R"	"O"	"H"	"S" MIN	"B" MIN	"L"
5233848	2	36.000	36.000	36.000	2.000	2.000	56.500
5233930	3	36.000	36.000	36.000	3.125	2.500	56.500
5233842	4	36.000	36.000	36.000	3.375	3.250	56.500

Dimensions are nominal

Schedule 40 90° Elbow 48" Radius Bell End

Part Number	Trade Size	"R"	"O"	"H"	"S" MIN	"B" MIN	"L"
5233876	2	48.000	48.000	48.000	2.000	2.000	75.375
5233817	3	48.000	48.000	48.000	3.125	2.500	75.375
5233843	4	48.000	48.000	48.000	3.375	3.250	75.375

Dimensions are nominal

Schedule 80 90° Elbow Special Radius - Bell End

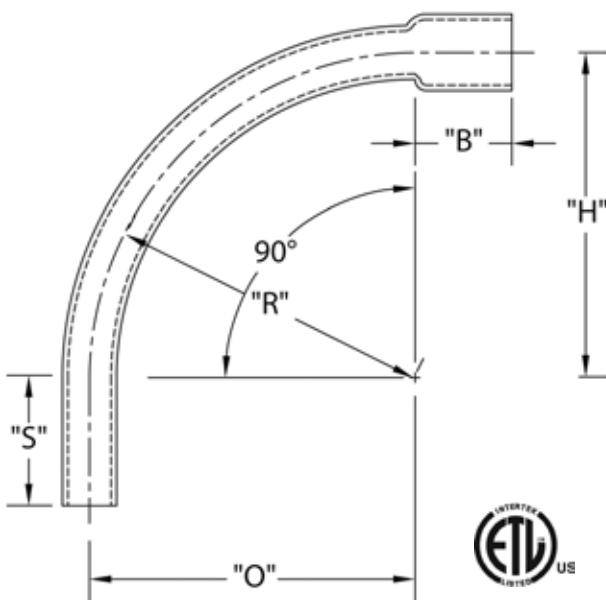

Schedule 80 90° Elbow 24" Radius Bell End

Part Number	Trade Size	"R"	"O"	"H"	"S" MIN	"B" MIN	"L"
5121036	2	24.000	24.000	24.000	2.000	2.000	37.688
5121031	3	24.000	24.000	24.000	3.125	2.500	37.688
5221022	4	24.000	24.000	24.000	3.375	3.250	37.688

Dimensions are nominal

Schedule 80 90° Elbow 36" Radius Bell End

Part Number	Trade Size	"R"	"O"	"H"	"S" MIN	"B" MIN	"L"
5121047	2	36.000	36.000	36.000	2.000	2.000	56.500
5121038	3	36.000	36.000	36.000	3.125	2.500	56.500
5221023	4	36.000	36.000	36.000	3.375	3.250	56.500

Dimensions are nominal

Schedule 80 90° Elbow 48" Radius Bell End

Part Number	Trade Size	"R"	"O"	"H"	"S" MIN	"B" MIN	"L"
5221075	2	48.000	48.000	48.000	2.000	2.000	75.375
5221082	3	48.000	48.000	48.000	3.125	2.500	75.375
5221024	4	48.000	48.000	48.000	3.375	3.250	75.375

Dimensions are nominal

Schedule 80 90° Elbow Special Radius - Bell End

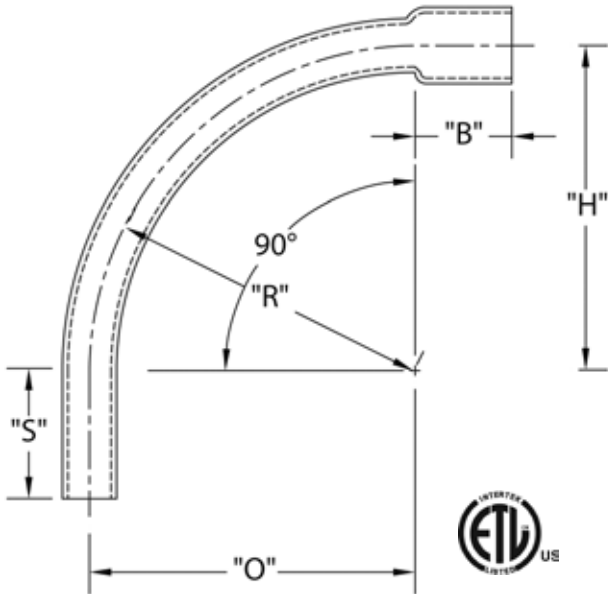

Schedule 80 90° Elbow 24" Radius Bell End

Part Number	Trade Size	"R"	"O"	"H"	"S" MIN	"B" MIN	"L"
5121036	2	24.000	24.000	24.000	2.000	2.000	37.688
5121031	3	24.000	24.000	24.000	3.125	2.500	37.688
5221022	4	24.000	24.000	24.000	3.375	3.250	37.688

Dimensions are nominal

Schedule 80 90° Elbow 36" Radius Bell End

Part Number	Trade Size	"R"	"O"	"H"	"S" MIN	"B" MIN	"L"
5121047	2	36.000	36.000	36.000	2.000	2.000	56.500
5121038	3	36.000	36.000	36.000	3.125	2.500	56.500
5221023	4	36.000	36.000	36.000	3.375	3.250	56.500

Dimensions are nominal

Schedule 80 90° Elbow 48" Radius Bell End

Part Number	Trade Size	"R"	"O"	"H"	"S" MIN	"B" MIN	"L"
5221075	2	48.000	48.000	48.000	2.000	2.000	75.375
5221082	3	48.000	48.000	48.000	3.125	2.500	75.375
5221024	4	48.000	48.000	48.000	3.375	3.250	75.375

Dimensions are nominal

Schedule 80 45° Elbow Special Radius - Bell End

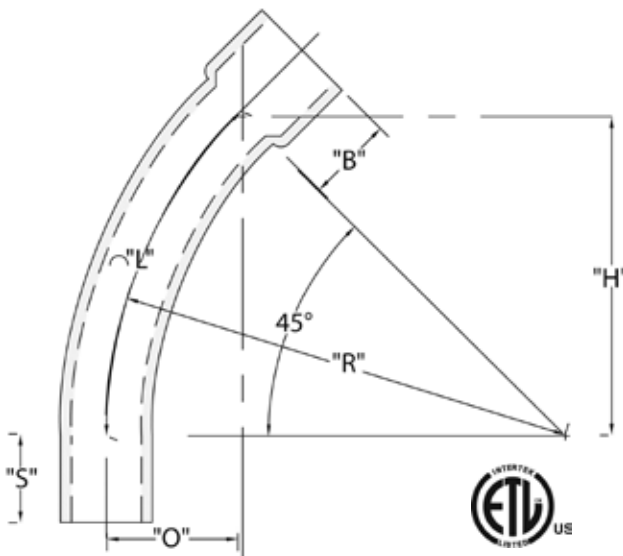

Schedule 80 45° Elbow 24" Radius Bell End

Part Number	Trade Size	"R"	"O"	"H"	"S" MIN	"B" MIN	"L"
5221101	2	24.000	7.000	17.000	2.000	2.000	18.875
5221014	3	24.000	7.000	17.000	3.125	2.500	18.875
5221089	4	24.000	7.000	17.000	3.375	3.250	18.875

Dimensions are nominal

Schedule 80 45° Elbow 36" Radius Bell End

Part Number	Trade Size	"R"	"O"	"H"	"S" MIN	"B" MIN	"L"
5221098	2	36.000	10.500	25.438	2.000	2.000	28.250
5221077	3	36.000	10.500	25.438	3.125	2.500	28.250
5219821	4	36.000	10.500	25.438	3.375	3.250	28.250

Dimensions are nominal

Schedule 80 45° Elbow 48" Radius Bell End

Part Number	Trade Size	"R"	"O"	"H"	"S" MIN	"B" MIN	"L"
5221078	3	48.000	14.000	33.938	3.125	2.500	37.688
5221091	4	48.000	14.000	33.938	3.375	3.250	37.688

Dimensions are nominal

Telephone Duct - Special Radius Elbows Bell End

CAO 90° Special Radius Elbows - Bell End

Part Number	Trade Size	"R"	"O"	"H"	"S" MIN	"B" MIN	"L"
5163856	4	24.000	24.000	24.000	6.000	6.000	37.688
5163850	4	36.000	36.000	36.000	6.000	6.000	56.500
5163859	4	48.000	48.000	48.000	6.000	6.000	75.375
5136853	4	60.000	60.000	60.000	6.000	6.000	94.250
5163857	4	150.000	150.000	150.000	6.000	6.000	235.625

Dimensions are nominal

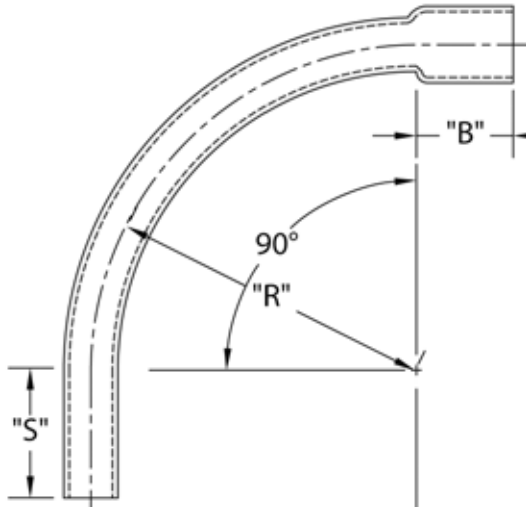

DBHM-60 90° Elbow Type DB Duct - Bell End

Part Number	Trade Size	"R"	"O"	"H"	"S" MIN	"B" MIN	"L"
5123867	2	24.000	24.000	24.000	2.000	2.000	37.688
5123868	2	36.000	36.000	36.000	2.000	2.000	56.500
5123865	2	48.000	48.000	48.000	2.000	2.000	75.375
5123871	3	24.000	24.000	24.000	3.125	2.500	37.688
5123872	3	36.000	36.000	36.000	3.125	2.500	56.500
5123869	3	48.000	48.000	48.000	3.125	2.500	75.375
5123875	4	24.000	24.000	24.000	3.375	3.250	37.688
5123876	4	36.000	36.000	36.000	3.375	3.250	56.500
5123877	4	48.000	48.000	48.000	3.375	3.250	75.375

Dimensions are nominal

Telephone Duct - Special Radius Elbows Bell End

CAO 45° Special Radius Elbows - Bell End

Part Number	Trade Size	"R"	"O"	"H"	"S" MIN	"B" MIN	"L"
5163748	4	24.000	7.000	17.000	6.000	6.000	17.000
5163750	4	36.000	10.500	25.438	6.000	6.000	25.438
5163753	4	48.000	14.000	33.313	6.000	6.000	33.938
5163763	4	60.000	17.563	42.375	6.000	6.000	42.375
5163758	4	150.000	52.750	127.250	6.000	6.000	106.063

Dimensions are nominal

DBHM-120 45° Special Radius Elbows - Bell End

Part Number	Trade Size	"R"	"O"	"H"	"S" MIN	"B" MIN	"L"
5125767	2	24.000	3.188	12.000	2.000	2.000	12.563
5125879	2	36.000	4.813	18.000	2.000	2.000	18.875
5125769	2	48.000	6.438	24.000	2.000	2.000	25.125
5125774	3	24.000	3.188	24.000	12.000	3.125	12.563
5125772	3	36.000	4.813	18.000	3.125	2.500	18.875
5125737	3	48.000	6.438	24.000	3.125	2.500	25.125
5125753	4	24.000	7.000	17.000	3.375	3.250	18.875
5125776	4	36.000	10.500	25.438	3.375	3.250	28.250
5125744	4	48.000	14.000	33.313	3.375	3.250	37.688

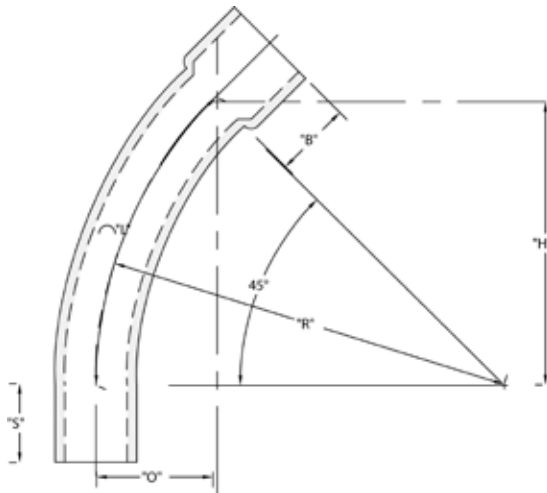

CAO 22-1/2° Special Radius Elbows Special Radius Elbows - Bell End

Part Number	Trade Size	"R"	"O"	"H"	"S" MIN	"B" MIN	"L"
5163638	4	24.000	3.188	12.000	3.375	3.250	12.563
5163630	4	36.000	4.813	18.000	3.375	3.250	18.875
5163631	4	48.000	6.438	24.000	3.375	3.250	25.125
5163627	4	60.000	4.563	23.000	3.375	3.250	23.563
5163644	4	300.000	4.000	114.500	3.375	3.250	114.50

Dimensions are nominal

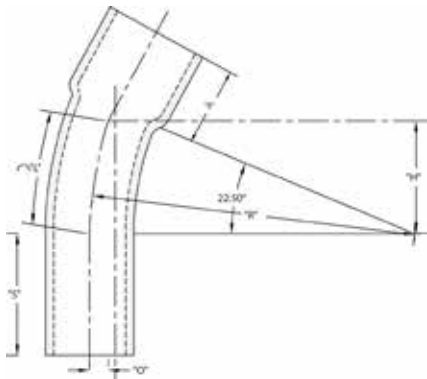

CAO 11-1/4° Special Radius Elbows Special Radius Elbows - Bell End

Part Number	Trade Size	"R"	"O"	"H"	"S" MIN	"B" MIN	"L"
5163616	4	24.000	.469	4.688	3.375	3.250	4.719
5163620	4	36.000	.688	7.000	3.375	3.250	7.063
5163615	4	48.000	.938	9.375	3.375	3.250	9.438

Dimensions are nominal

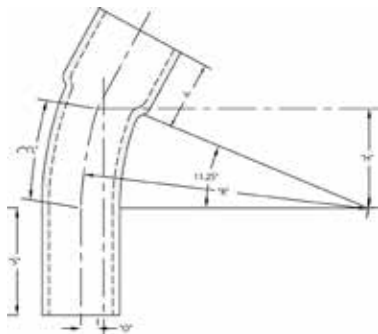

Telephone Duct - 22-1/2° & 11-1/4° Elbows Bell End

DBHM-120 22-1/2° Special Radius Elbows - Bell End

Part Number	Trade Size	"R"	"O"	"H"	"S" MIN	"B" MIN	"L"
5125763	2	24.000	1.813	9.188	2.000	1.5	9.438
5125768	2	36.000	2.750	13.750	2.000	2.000	14.125
5125825	2	48.000	3.625	18.375	2.000	2.000	18.875
5125805	3	24.000	1.813	9.188	3.125	2.500	9.438
5125773	3	36.000	2.750	13.750	3.125	2.500	14.125
5125794	4	24.000	1.813	9.188	3.375	3.250	9.438
5125750	4	36.000	2.750	13.750	3.375	3.250	14.125
5125733	4	48.000	3.625	18.375	3.375	3.250	18.875

Dimensions are nominal

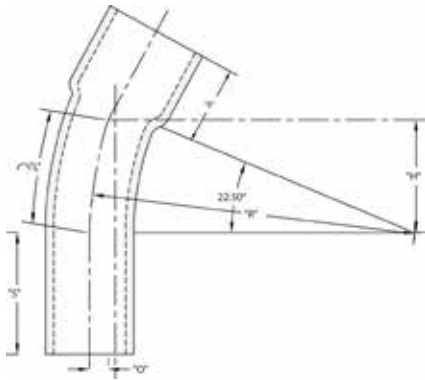

Schedule 40 22-1/2° Special Radius Elbows Bell End



Part Number	Trade Size	"R"	"O"	"H"	"S" MIN	"B" MIN	"L"
5233915	2	24.000	1.813	9.188	2.000	1.5	9.438
5233851	2	36.000	2.750	13.750	2.000	2.000	14.125
5233904	2	48.000	3.625	18.375	2.000	2.000	18.875
5233903	3	24.000	1.813	9.188	3.125	2.500	9.438
5233904	3	36.000	2.750	13.750	3.125	2.500	14.125
5233909	4	24.000	1.813	9.188	3.375	3.250	9.438
5233853	4	36.000	2.750	13.750	3.375	3.250	14.125
5233932	4	48.000	3.625	18.375	3.375	3.250	18.875

Dimensions are nominal

Schedule 40 11-1/4° Special Radius Elbows - Bell End

Part Number	Trade Size	"R"	"O"	"H"	"S" MIN	"B" MIN	"L"
5233974	2	24.000	.469	4.688	2.000	2.000	4.719
5233991	4	24.000	.469	4.688	3.375	3.250	4.719
5233963	2	36.000	.688	7.000	2.000	2.000	7.063
5234082	3	36.000	.688	7.000	3.125	2.500	7.063
5233910	4	36.000	.688	7.000	3.375	3.250	7.063
5233990	4	48.000	.938	9.375	3.375	3.250	9.438

Dimensions are nominal

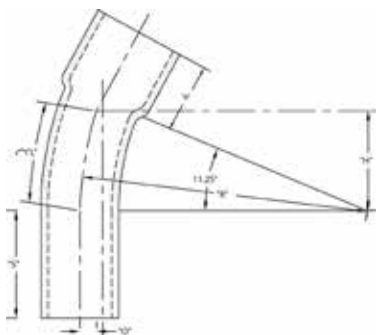

Solvent Cement & Primer



**CANTEX PVC cement and primer are for use on rigid PVC Electrical Conduit.
DO NO USE FOR WATER, SEWER OR DWV INSTALLATIONS.**

Solvent Cement & Primer for Conduit and Fittings

CANTEX PVC cement and primer are for use on rigid PVC Electrical conduit and fittings.

DO NOT USE FOR WATER, SEWER OR DWV INSTALLATIONS.

Conduit Cement No. 99



Part Number	Size	Carton Qty.
7210601	1/2 Pint	24
7210602	Pint	12
7210603	Quart	12

Conduit Cement No. 99 - Gray



Part Number	Size	Carton Qty.
7210502	Pint	12
7210503	Quart	12

Conduit All Weather Cement



Part Number	Size	Carton Qty.
7210411	1/2 Pint	24
7210412	Pint	12
7210413	Quart	12

Conduit Primer No. 10



Part Number	Size	Carton Qty.
7211301	1/2 Pint	24
7211302	Pint	12
7211303	Quart	12

ESTIMATED SOLVENT REQUIREMENT PER 1,000 FEET IN QUARTS One weld per 20 feet

Pipe Size	1/2"	3/4"	1"	1-1/4"	1-1/2"	2"	2-1/2"	3"	4"	5"	6"
Cement	1/2	1/2	1/2	1	1	1	1-1/2	1-1/2	2	2-1/2	4
Primer	1/2	1/2	1/2	1	1	1	1-1/2	1-1/2	2	2-1/2	4

ENT NO. 50 Cement Solvent Cement for EZ-FLEX ENT



Part Number	Size	Carton Qty.
7210402	Pint	12
7210403	Quart	12

EZ BOX[®] FROM CANTEX[®]

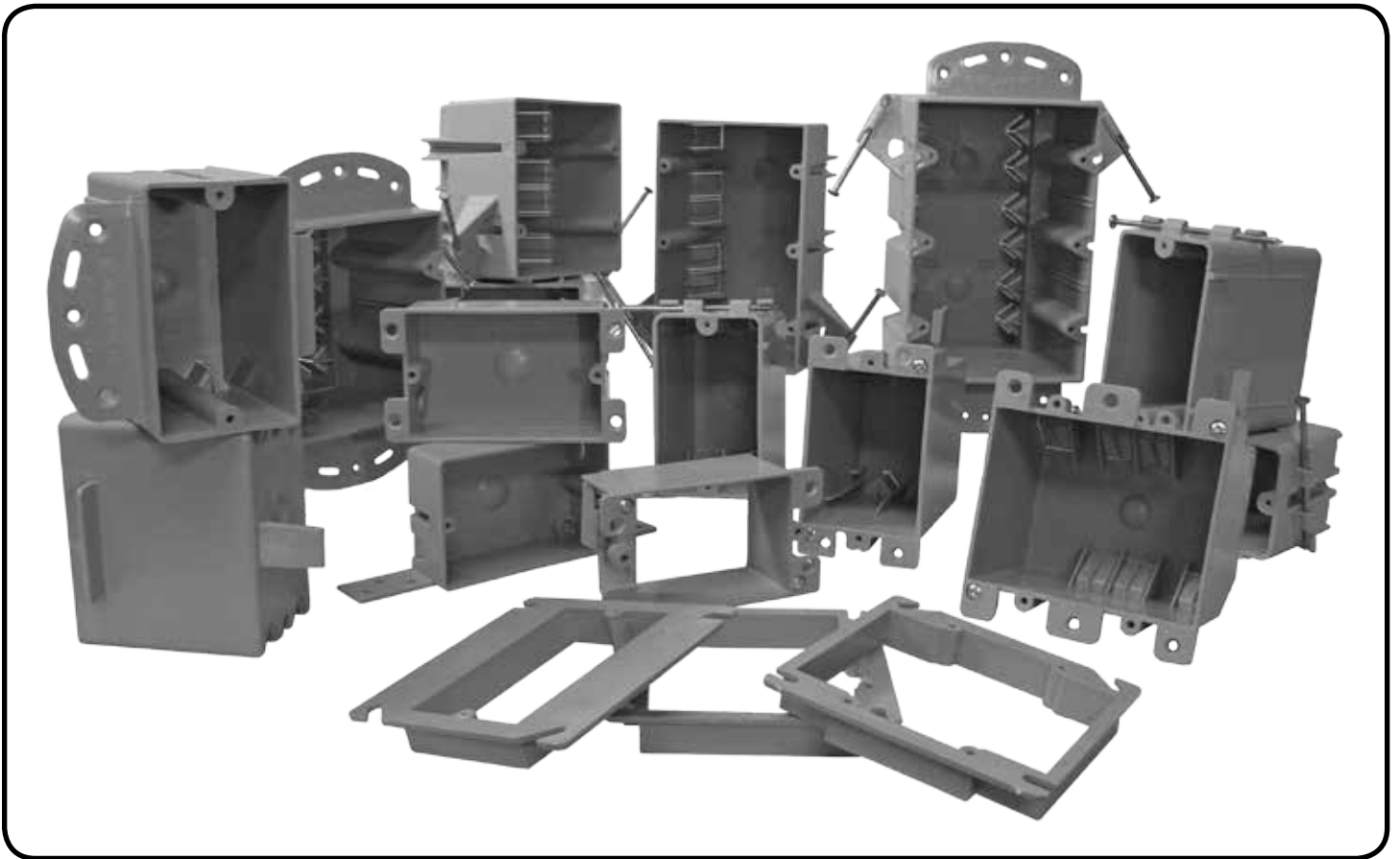

EZ BOX® Residential Switch/Outlet Boxes

EZ BOX® Single Gang Nail On Residential Box

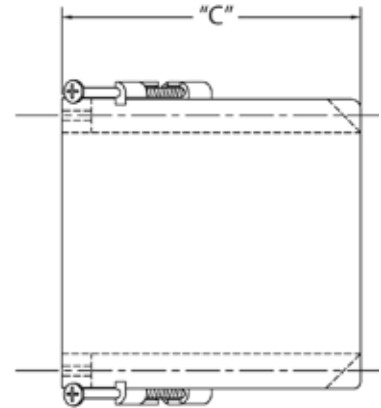
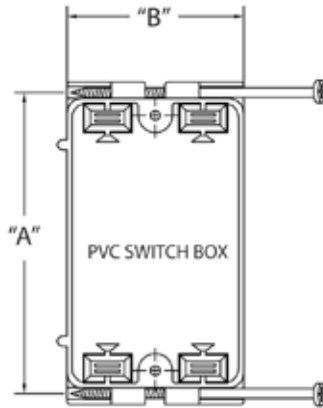

Four knockouts
Enhanced angled nails for quick mounting between studs.

18 Cubic Inch

Part Number	Carton Quantity	"A"	"B"	"C"
EZ18SNW	100	3.875	2.250	2.875

Dimensions are nominal

20.3 Cubic Inch

Part Number	Carton Quantity	"A"	"B"	"C"
EZ20SNW	100	3.875	2.250	3.125

Dimensions are nominal

23 Cubic Inch

Part Number	Carton Quantity	"A"	"B"	"C"
EZ23SNW	100	3.875	2.259	3.500

Dimensions are nominal

EZ BOX® Single Gang Nail On Residential Box

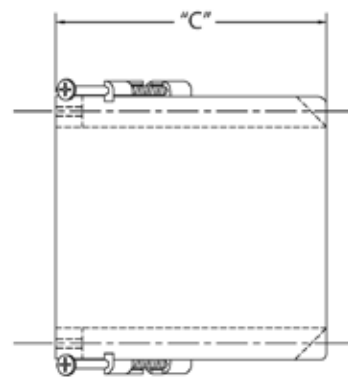
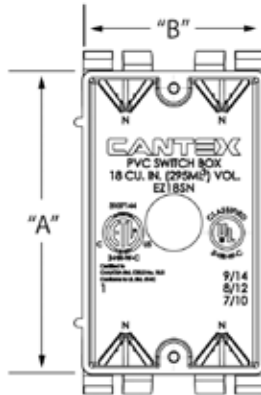

Four clamps
Enhanced angled nails for quick mounting between studs.

18 Cubic Inch

Part Number	Carton Quantity	"A"	"B"	"C"
EZ18SN	100	3.700	2.250	2.840
EZ18SNV	25	3.700	2.250	2.840

Dimensions are nominal

20.3 Cubic Inch

Part Number	Carton Quantity	"A"	"B"	"C"
EZ20SN	100	3.700	2.250	3.130
EZ20SNV	25	3.700	2.250	3.130

Dimensions are nominal

23 Cubic Inch

Part Number	Carton Quantity	"A"	"B"	"C"
EZ23SN	100	3.700	2.250	3.600
EZ23SNV	25	3.700	2.250	3.600

Dimensions are nominal

EZ BOX® Residential Switch/Outlet Boxes

EZ BOX® Single Gang Screw Nail Residential Box

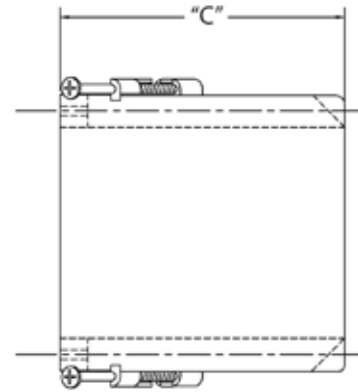
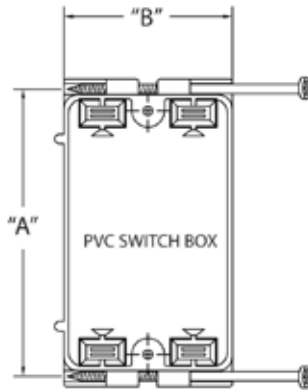

Four knockouts

Designed for use on aluminum, light to medium grade steel or wood studs. The sharp point, slotted head and threaded body allows for installation using a power screwdriver without having to pre-drill. It can just as easily be installed on wood studs using a hammer.

18 Cubic Inch

Part Number	Carton Quantity	"A"	"B"	"C"
EZ18SNZ	100	3.875	2.250	2.875

Dimensions are nominal

20.3 Cubic Inch

Part Number	Carton Quantity	"A"	"B"	"C"
EZ20SNZ	100	3.875	2.250	3.125

Dimensions are nominal

23 Cubic Inch

Part Number	Carton Quantity	"A"	"B"	"C"
EZ23SNZ	100	3.875	2.259	3.500

Dimensions are nominal

EZ BOX® Single Gang Nail On Residential Box with Express Clip

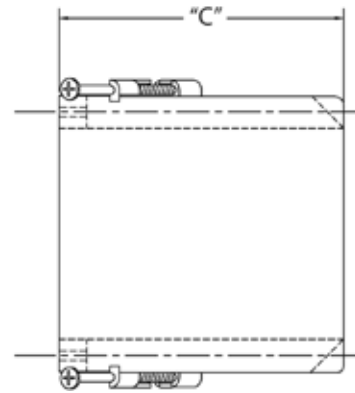
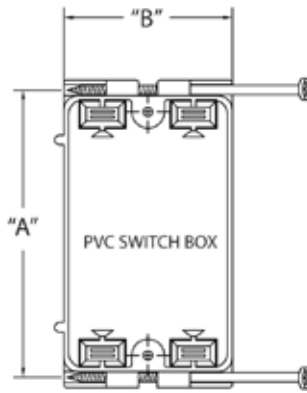

Four knockouts

The Express Clip® is designed to provide EZ installation of electrical devices. With a hammer, tap the device screw. Turn the screw an approximate quarter turn for a quick, secure installation.

18z Cubic Inch

Part Number	Carton Quantity	"A"	"B"	"C"
EZ18SNU	100	3.875	2.250	2.875

Dimensions are nominal

20.3 Cubic Inch

Part Number	Carton Quantity	"A"	"B"	"C"
EZ20SNU	100	3.875	2.250	3.125

Dimensions are nominal

23 Cubic Inch

Part Number	Carton Quantity	"A"	"B"	"C"
EZ23SNU	100	3.875	2.259	3.500

Dimensions are nominal

EZ BOX® Residential Switch/Outlet Boxes

EZ BOX® Two Gang Nail On Residential Box

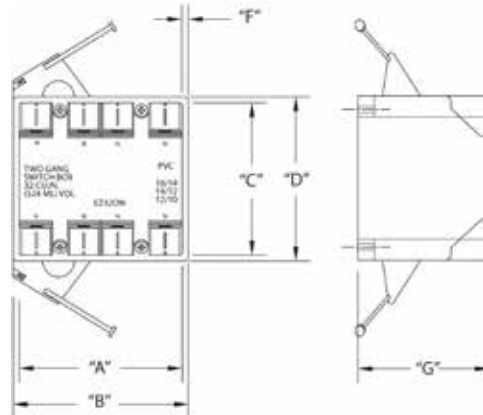

Eight clamps
Enhanced angled nails for quick mounting between studs.

32 Cubic Inch

Part Number	Carton Quantity	"A"	"B"	"C"	"D"	"E"	"F"	"G"
EZ32DN	50	3.813	3.938	3.500	3.688	.094	3.063	3.063

Dimensions are nominal

EZ BOX® Two Gang Residential Box with Screw Nail

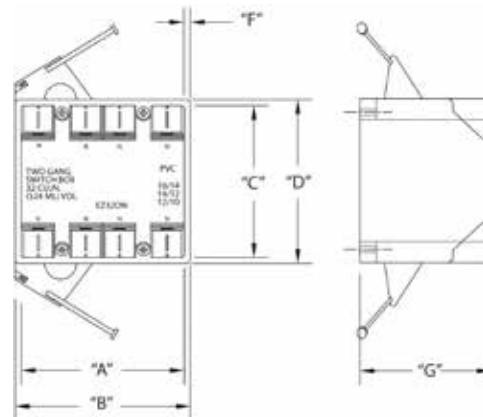

Eight clamps
Enhanced angled nails for quick mounting between studs.
Designed for use on aluminum, light to medium grade steel or wood studs.

32 Cubic Inch

Part Number	Carton Quantity	"A"	"B"	"C"	"D"	"E"	"F"	"G"
EZ32DNZ	50	3.813	3.938	3.500	3.688	.094	3.063	3.063

Dimensions are nominal

EZ BOX® Residential Switch/Outlet Boxes

EZ BOX® Three Gang Residential Box

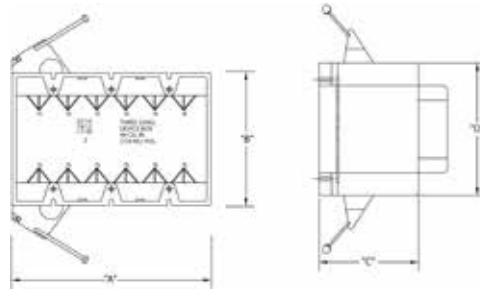

Eight clamps

Enhanced angled nails for quick mounting between studs.

44 Cubic Inch

Part Number	Carton Quantity	"A"	"B"	"C"	"D"
EZ44TN	50	5.800	3.700	2.750	3.700

Dimensions are nominal

EZ BOX® Three Gang Residential Box with Screw Nail

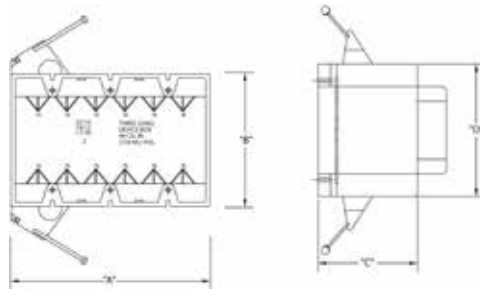

Eight clamps

Enhanced angled nails for quick mounting between studs.

Designed for use on aluminum, light to medium grade steel or wood studs.

44 Cubic Inch

Part Number	Carton Quantity	"A"	"B"	"C"	"D"
EZ44TNZ	50	5.800	3.700	2.750	3.700

Dimensions are nominal

EZ BOX® Residential Switch/Outlet Boxes

EZ BOX® Four Gang Residential Box with Nails and Adjustable Bracket



Twelve clamps and adjustable bracket for quick, secure mounting between studs

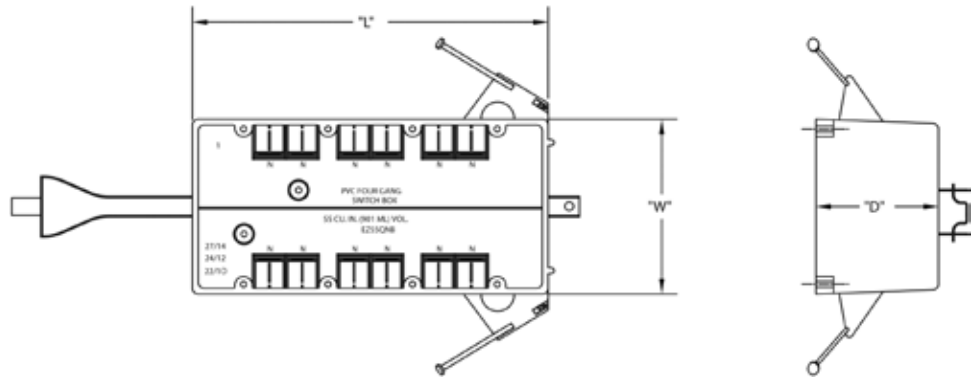

55 Cubic Inch

Part Number	Carton Quantity	"L"	"W"	"D"
EZ55QNB	25	7.625	3.625	2.625

Dimensions are nominal

EZ BOX® Four Gang Residential Box with Screw Nail and Adjustable Bracket



Twelve clamps, enhanced angled screw-nails and adjustable bracket provides easy, secure installation.

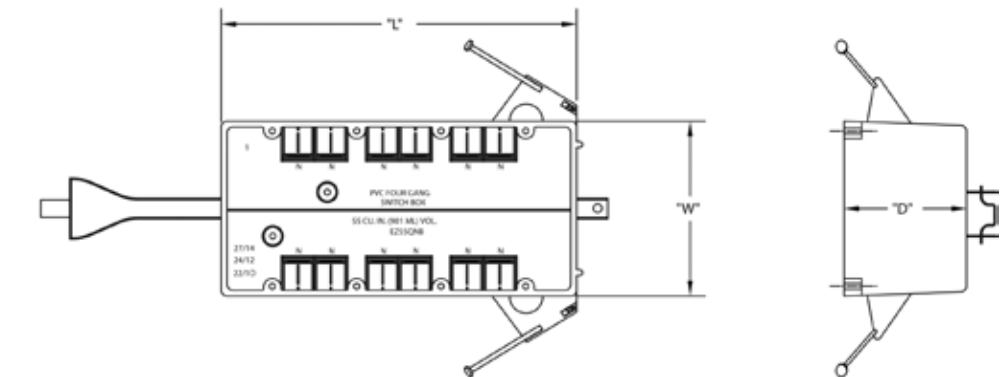

55 Cubic Inch

Part Number	Carton Quantity	"L"	"W"	"D"
EZ55QNBZ	25	7.625	3.625	2.625

Dimensions are nominal

EZ BOX® Residential Switch/Outlet Boxes

EZ BOX® Single Gang Steel Stud Residential Box

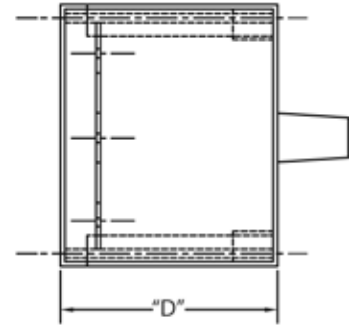
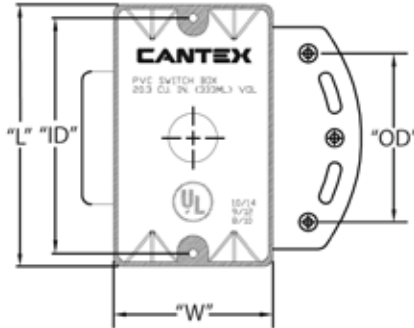

Four Clamps

Bracketed for steel stud installations
Bracket is molded with the box.

20.3 Cubic Inch

Part Number	Carton Quantity	"D"	"L"	"ID"	"OD"	"W"
EZ20SB	100	3.188	3.688	3.250	2.875	2.250

Dimensions are nominal

EZ BOX® Multi-Gang Residential Box for Steel or Wood Studs

MULTI-GANG BOX

- Largest PVC cubic inch box on the market
- Accepts larger wiring devices; (i.e. dimming switches, fan switches, FGCI, motion sensors)
- Allows for additional wire capacity
- Can be used with wood or steel studs
- Dividers are available to partition boxes for installation of low voltage/communication applications
- Contractor preferred clamps lock wiring in place

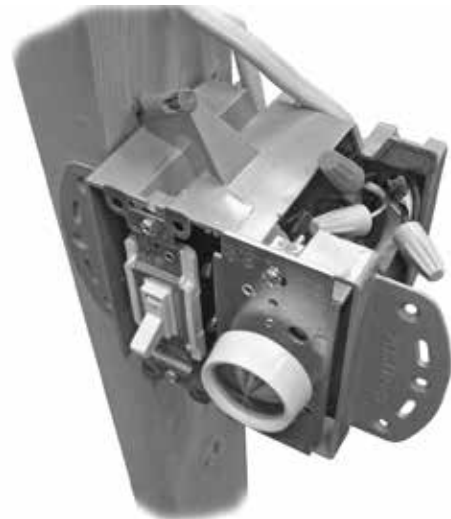

**48 cu. in.
TWO GANG BOX
EZ48DN**



Contractor Preferred Clamp



**74 cu. in.
THREE GANG BOX
EZ74TN**

EZ BOX® Residential Switch/Outlet Boxes

EZ BOX® Two Gang Residential Box for Steel or Wood Studs



Six clamps
Bracketed for steel stud installations
Bracket is molded with the box.

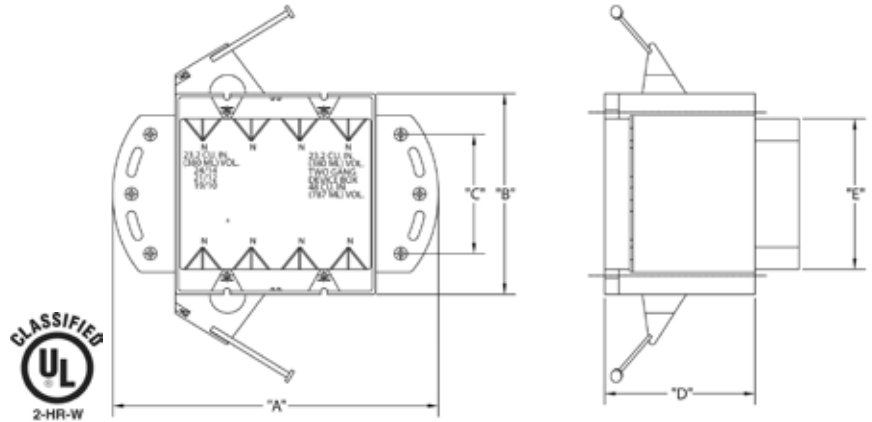

48 Cubic Inch

Part Number	Carton Quantity	"A"	"B"	"C"	"D"	"E"
EZ48DN	50	6.688	4.000	2.625	3.000	2.875

Dimensions are nominal

EZ BOX® Two Gang Residential Box for Steel or Wood Studs with Screw Nail



Six clamps
Bracketed for steel stud installations
Bracket is molded with the box.

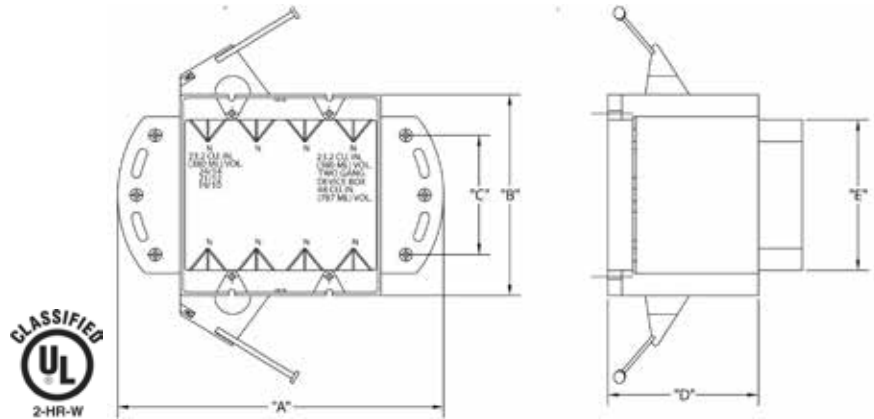

48 Cubic Inch

Part Number	Carton Quantity	"A"	"B"	"C"	"D"	"E"
EZ48DNZ	50	6.688	4.000	2.625	3.000	2.875

Dimensions are nominal

EZ BOX® Residential Switch/Outlet Boxes

EZ BOX® Three Gang Residential Box for Steel or Wood Studs

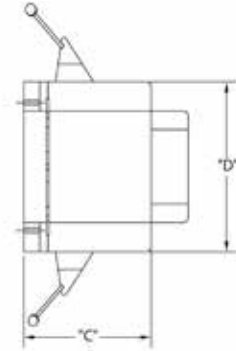
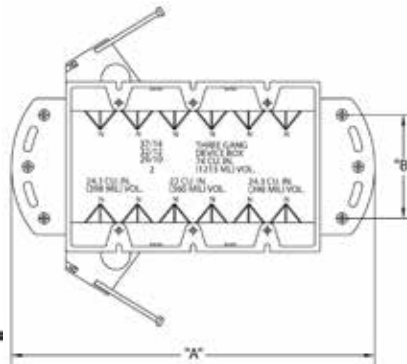

Twelve clamps

Bracketed for steel stud installations
Bracket is molded with the box.

74 Cubic Inch

Part Number	Carton Quantity	"A"	"B"	"C"	"D"
EZ74TN	50	8.375	2.625	3.000	4.000

Dimensions are nominal

EZ BOX® Three Gang Residential Box for Steel or Wood Studs with Screw Nail

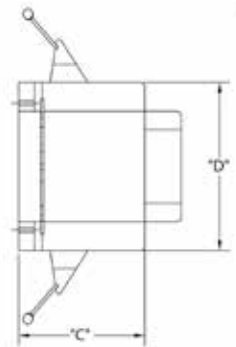
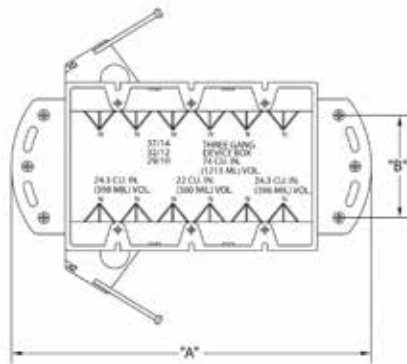

Twelve clamps

Bracketed for steel stud installations
Bracket is molded with the box.

74 Cubic Inch

Part Number	Carton Quantity	"A"	"B"	"C"	"D"
EZ74TNZ	50	8.375	2.625	3.000	4.000

Dimensions are nominal

EZ BOX® Residential Switch/Outlet Boxes

EZ BOX® Non-conductive Divider for Use with Low Voltage Devices

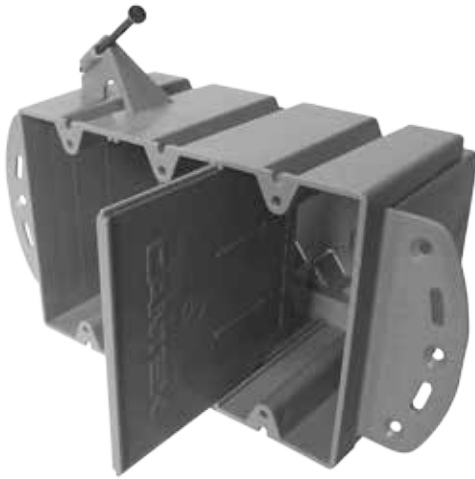

Used to divide multi-gang, maximum capacity boxes to allow installation of communication device with standard switch or outlet. Fits two or three gang maximum capacity EZ Box®.

Low Voltage Divider

Part Number	Carton Quantity	"A"	"B"	"C"	"D"	"E"	"F"
EZLVD	50	3.834	2.778	3.870	2.970	2.749	3.732

Dimensions are nominal

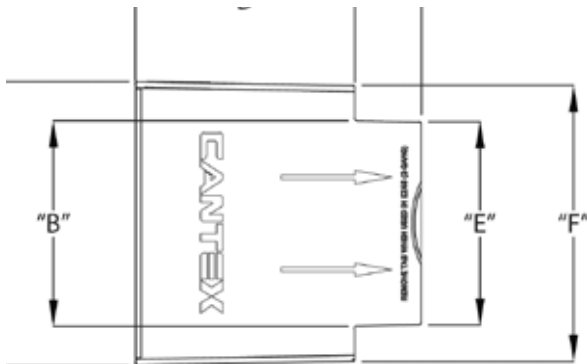

USE WITH THESE EZ BOX® MULTI-GANG RESIDENTIAL BOXES

- EZ48DN - Two Gang with Nails
- EZ48DNZ - Two Gang with Screw Nails
- EZ74TN - Three Gang with Nails
- EZ74TNZ - Three Gang with Screw Nails

EZ BOX® Residential Switch/Outlet Boxes

EZ BOX® Heavy Wall Switch/Outlet Boxes

22 Cubic Inch Single Gang Box

Part Number	Carton Quantity	Width	Height	Depth
EZ22SN-HW	100	2.35	3.28	2.89

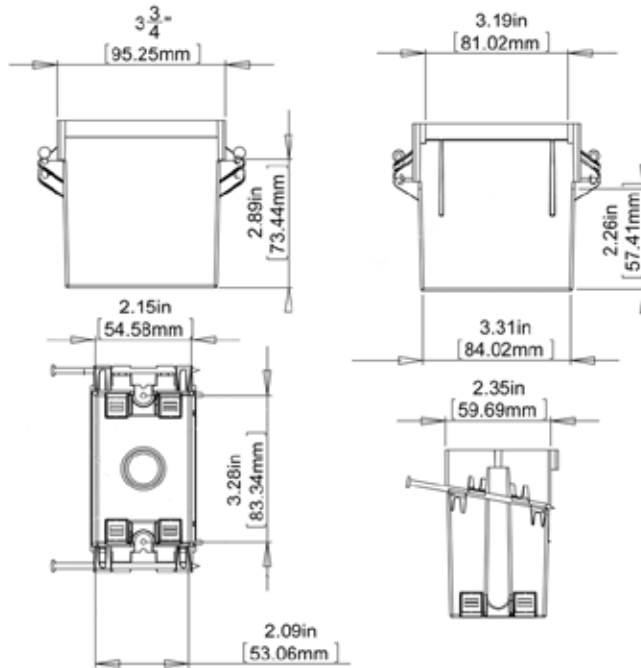
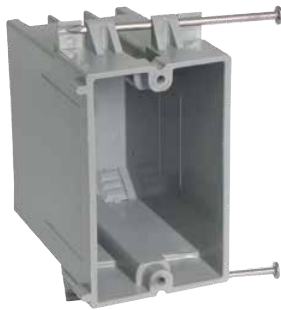

35 Cubic Inch Two Gang Box

Part Number	Carton Quantity	Width	Height	Depth
EZ35DN-HW	48	4.17	3.85	3.59

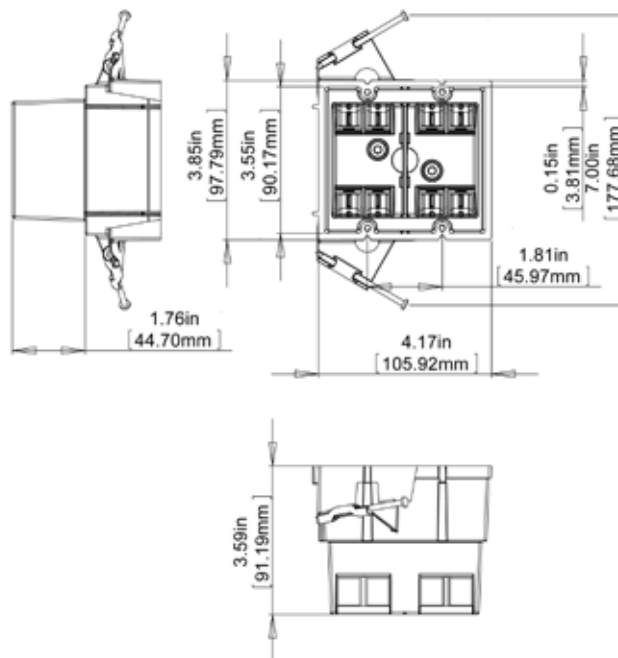

EZ BOX® Residential Switch/Outlet Boxes

EZ BOX® Heavy Wall Switch/Outlet Boxes

53 Cubic Inch Three Gang Box

Part Number	Carton Quantity	Width	Height	Depth
EZ53TN-HW	24	5.90	3.55	3.50

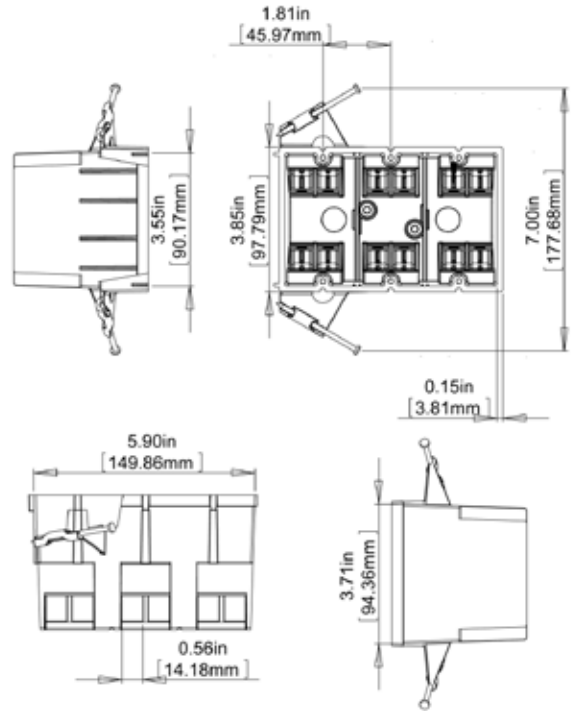
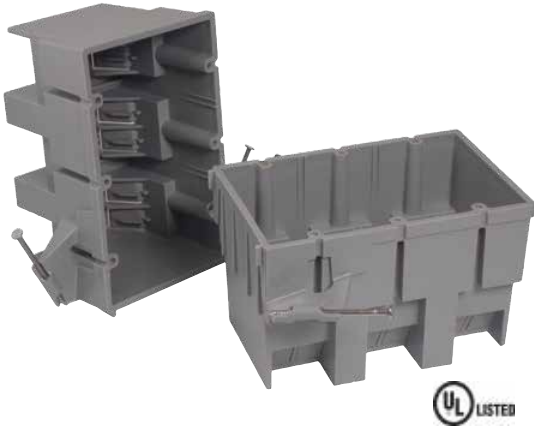

64 Cubic Inch Four Gang Box

Part Number	Carton Quantity	Width	Height	Depth
EZ64QN-HW	24	7.76	3.85	3.50

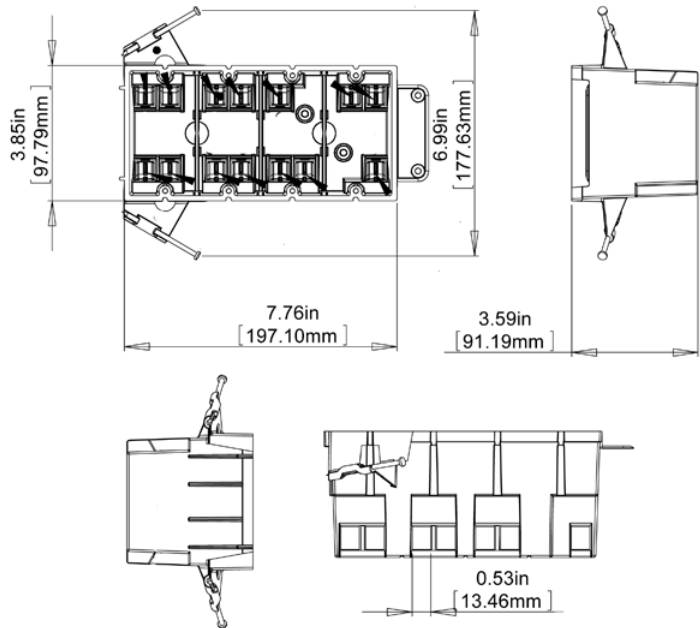
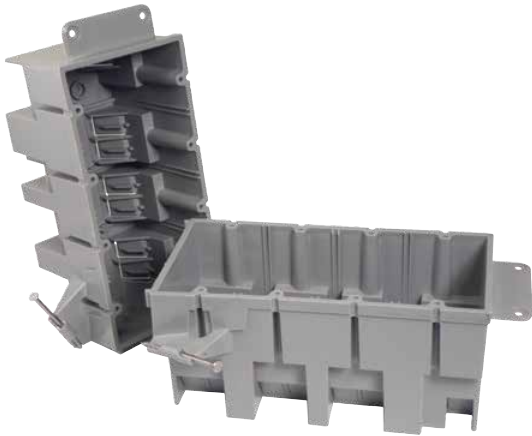

EZ BOX® Residential Switch/Outlet Boxes

EZ BOX® Heavy Wall Ceiling Boxes

25 Cubic Inch Ceiling Box

Part Number	Carton Quantity	Width	Height	Depth
EZ25CN-HW	24	4.00	4.00	3.00

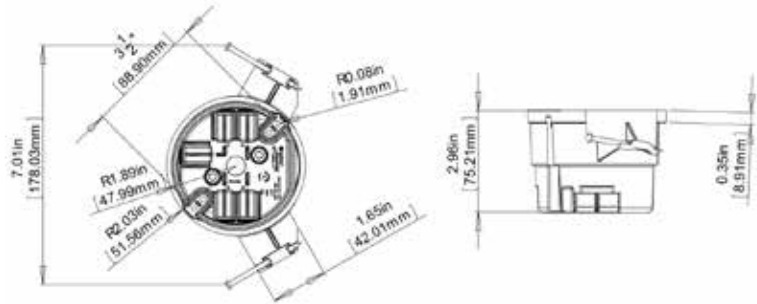

25 Cubic Inch Ceiling Box with Ground Lug

Part Number	Carton Quantity	Width	Height	Depth
EZ25CNG-HW	24	4.00	4.00	3.00

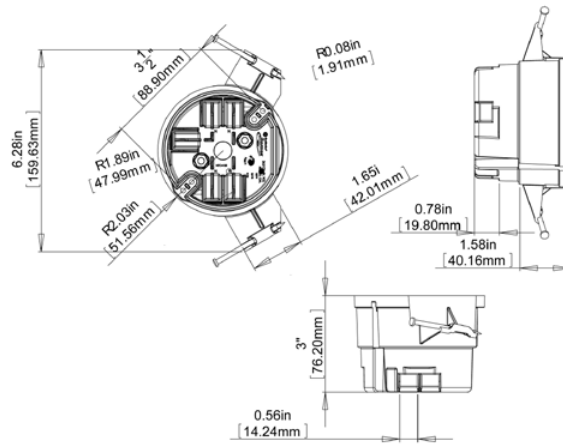

25 Cubic Inch Ceiling Fan Box with L-Bracket

Part Number	Carton Quantity	Width	Height	Depth
EZ25CF-HW	24	4.00	4.00	3.00

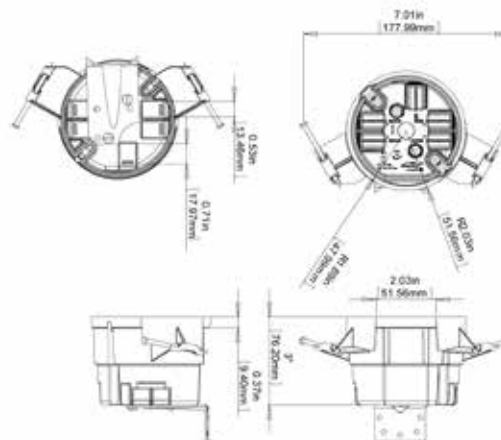

EZ BOX® Residential Switch/Outlet Boxes

EZ BOX® Heavy Wall Ceiling Boxes

25 Cubic Inch Ceiling Box with Hanging Bar

Part Number	Carton Quantity	Width	Height	Depth
EZ25CH-HW	20	4.00	4.00	3.00

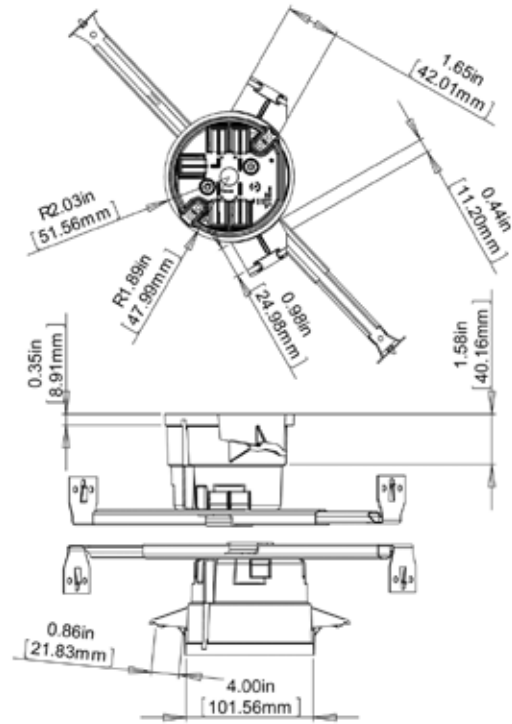

25 Cubic Inch Ceiling Box with Hanging Bar & Ground Lug

Part Number	Carton Quantity	Width	Height	Depth
EZ25CHG-HW	20	4.00	4.00	3.00

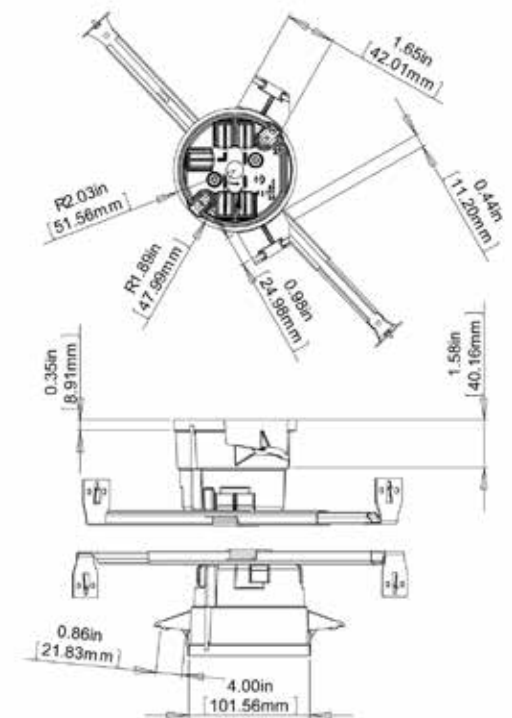

EZ BOX® Residential Switch/Outlet Boxes

EZ BOX® Handy Wall Box & Covers



- Multi-Purpose Electrical Switch/Outlet Box
- Four cover styles available
- Easy to install
- Meets NEMA specifications

21 Cubic Inch Single Gang Adjustable Box

Part Number	Carton Quantity	Width	Height	Depth
EZ12SO	50	2.13	3.90	1.93

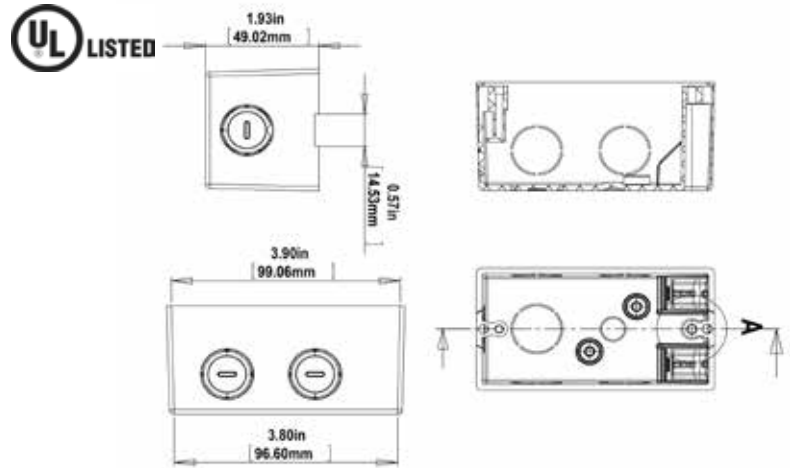

Switch Cover

Part Number	Carton Quantity
EZSL-TGL	25

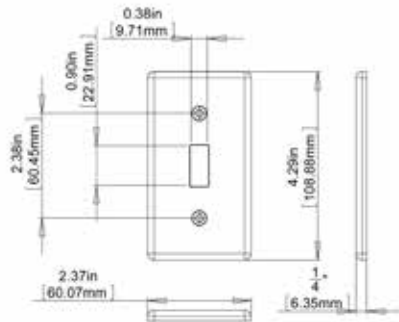

Duplex Cover

Part Number	Carton Quantity
EZSL-DPLX	25

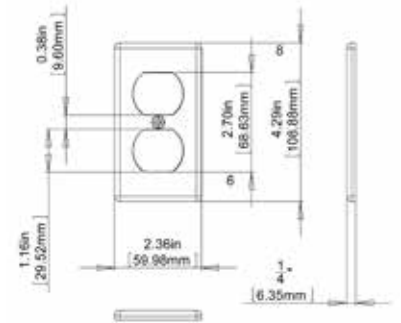

Blank Cover

Part Number	Carton Quantity
EZSL-BLANK	25

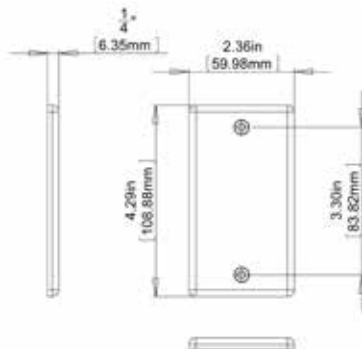

GFCI Receptacle Cover

Part Number	Carton Quantity
EZSL-GFCI	25

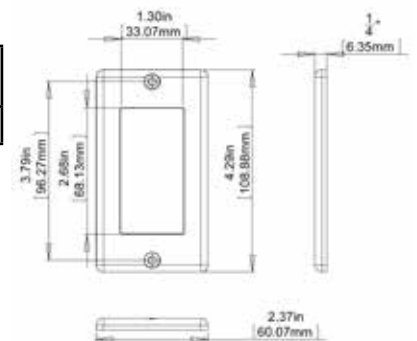

EZ BOX® Residential Switch/Outlet Boxes

EZ BOX® Vapor Proof Boxes

- Energy efficient electrical boxes for exterior walls eliminates air leaks
- Available in one, two and three gang switch/outlet boxes and the round ceiling box
- Meets NEMA specifications

23 Cubic Inch Single Gang Box

Part Number	Carton Quantity	Width	Height	Depth
EZ23SN-RG	60	2.10	2.28	3.74

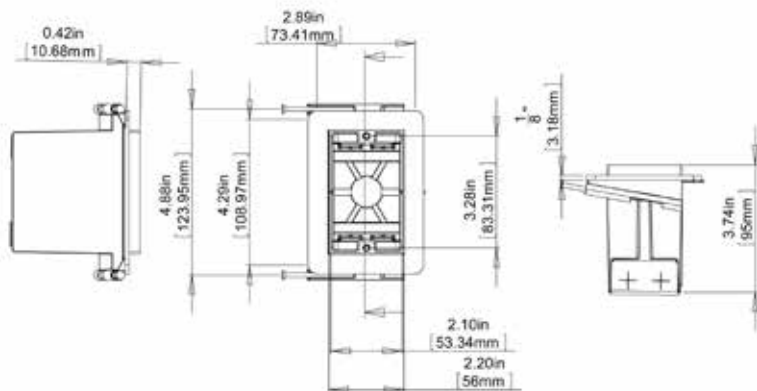

36 Cubic Inch Two Gang Box

Part Number	Carton Quantity	Width	Height	Depth
EZ36DN-RG	48	3.688	3.410	3.300

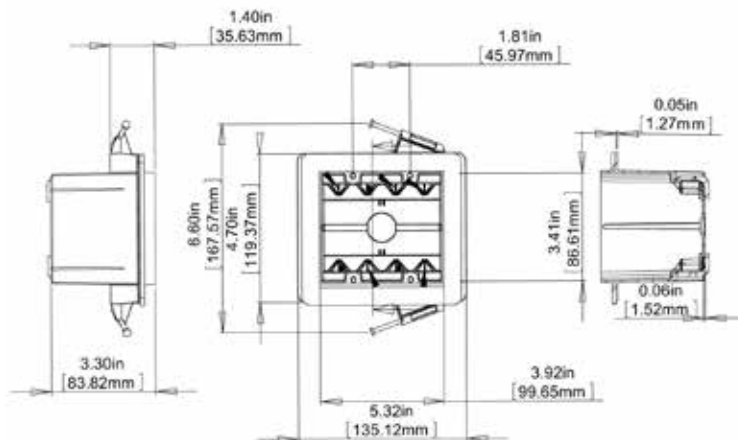

EZ BOX® Residential Switch/Outlet Boxes

EZ BOX® Vapor Proof Boxes

54 Cubic Inch Three Gang Box

Part Number	Carton Quantity	Width	Height	Depth
EZ54TN-RG	24	7.163	4.69	3.25

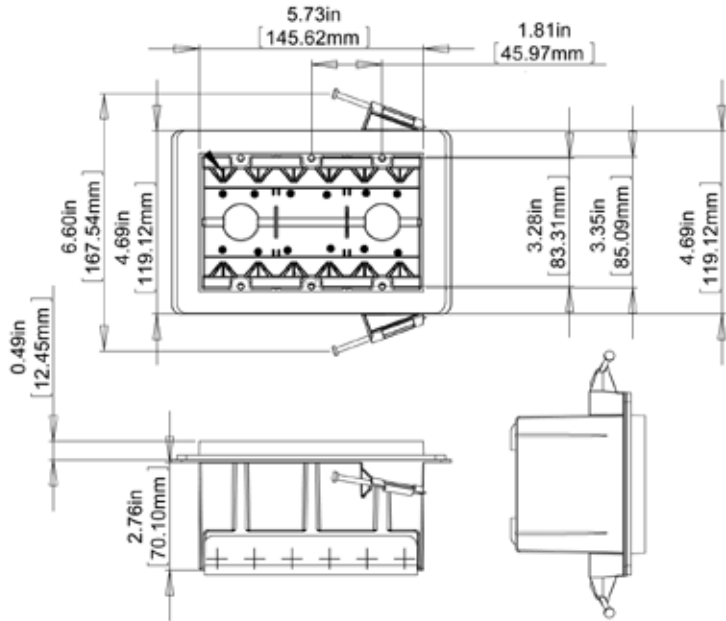

EZ BOX® Vapor Proof Ceiling Box

26 Cubic Inch Ceiling Box

Part Number	Carton Quantity	Width	Height	Depth
EZ26CN-RG	48	3.960	3.960	2.740



Suitable for fixture support only.
50 lbs. maximum

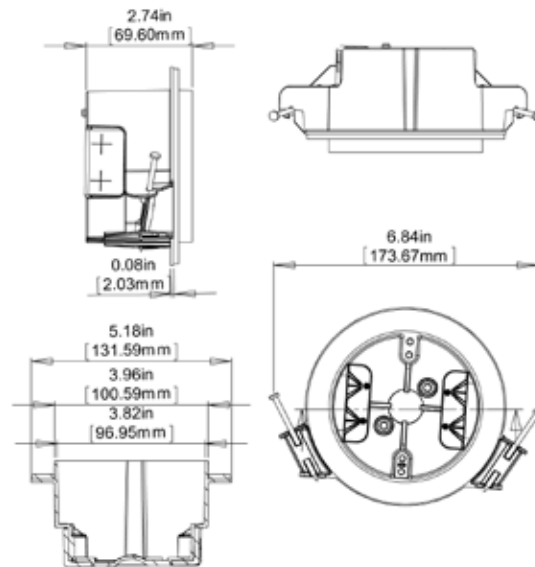

EZ BOX® Residential Switch/Outlet Boxes

EZ BOX® ENT Switch/Outlet Boxes

- Full product offering of 1 & 2 gang boxes
- Used with ENT snap-in fittings or standard Schedule 40 fittings

22 Cubic Inch Single Gang Box

Part Number	Carton Quantity	Width	Height	Depth
EN22SB	25	2.10	3.69	3.13

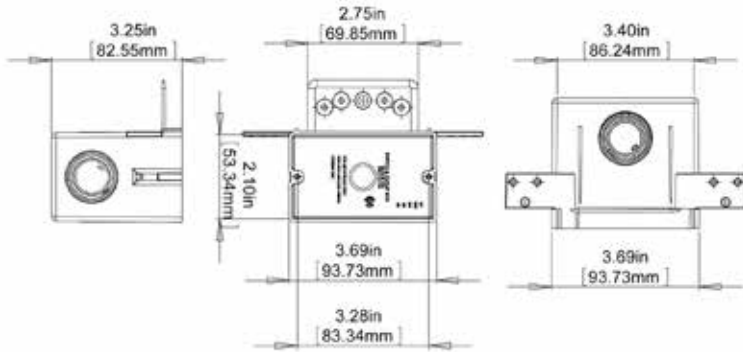

16 Cubic Inch Single Gang Box

Part Number	Carton Quantity	Width	Height	Depth
EN16SB	25	2.10	3.28	2.97

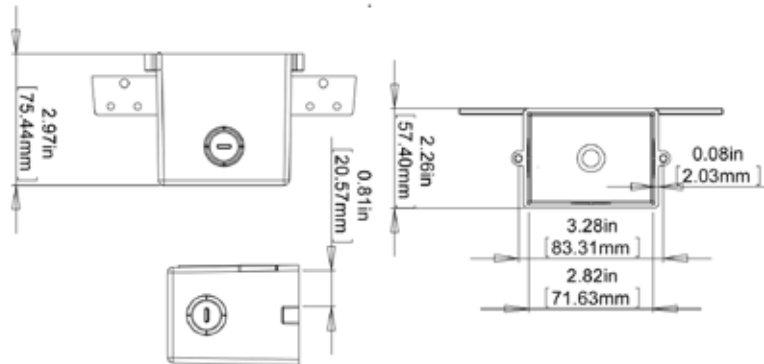

38 Cubic Inch Two Gang Box

Part Number	Carton Quantity	Width	Height	Depth
EN38DB	25	3.96	3.70	3.75

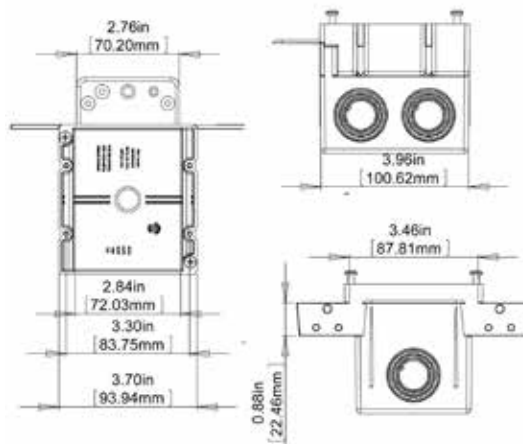
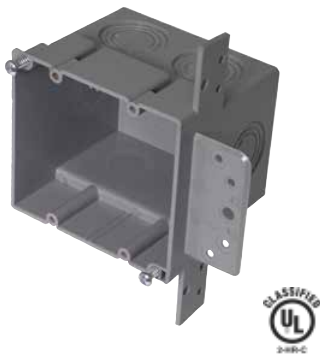

EZ BOX® Residential Switch/Outlet Boxes

EZ BOX® ENT Ceiling Boxes

Suitable for fixture support only

50 lbs. maximum

20 Cubic Inch Ceiling Box

Part Number	Carton Quantity	Width	Height	Depth
EN20CB	50	4.16	4.16	2.20

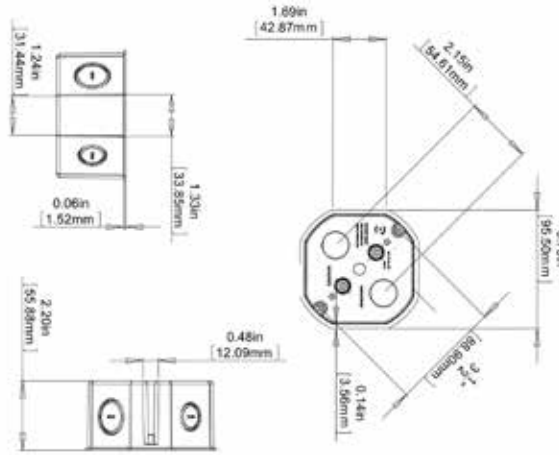

20 Cubic Inch Ceiling Box with L-Bracket

Part Number	Carton Quantity	Width	Height	Depth
EN20CBL	50	4.16	4.16	2.20

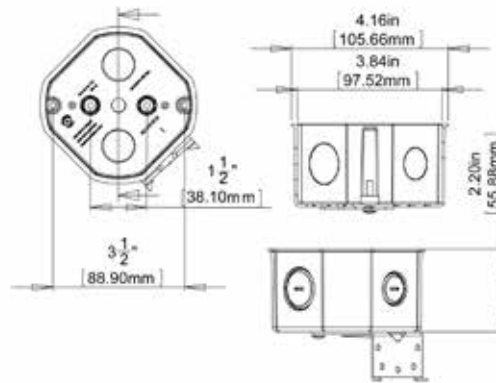

EZ BOX® Residential Switch/Outlet Boxes

EZ BOX® Low Voltage Brackets

- Open back easily accommodates low voltage wiring
- Used with ENT
- Fits standard faceplates
- Product variety for new and remodel construction

Single Gang Old Work Bracket

Part Number	Carton Quantity	Width	Height	Depth
EZLV1-OW	12	2.60	4.30	.44

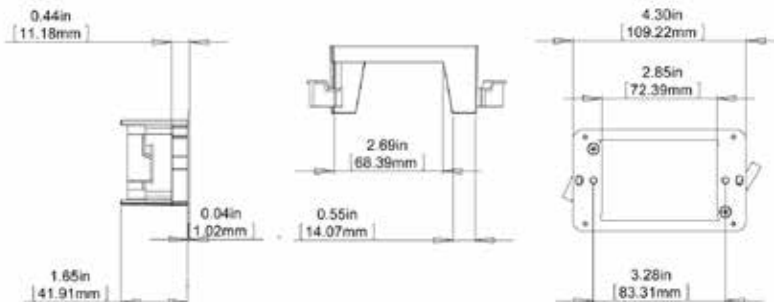

Single Gang Add-On Bracket

Part Number	Carton Quantity	Width	Height	Depth
EZLVSB	24	1.78	2.75	2.25

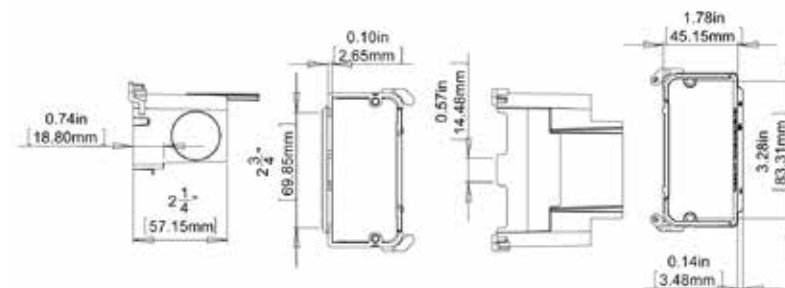

Single Gang Bracket with Nails

Part Number	Carton Quantity	Width	Height	Depth
EZLV1-NWN	24	2.16	3.73	1.50

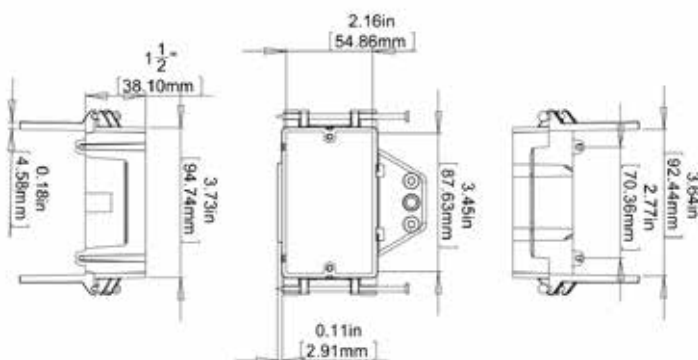

EZ BOX® Residential Switch/Outlet Boxes

EZ BOX® Low Voltage Brackets

Two Gang Old Work Bracket

Part Number	Carton Quantity	Width	Height	Depth
EZLV2-OW	6	4.30	4.31	.43



Two Gang Dual Voltage Box/Bracket with Nails

Part Number	Carton Quantity	Width	Height	Depth
EDV2B	16	3.91	3.67	3.63

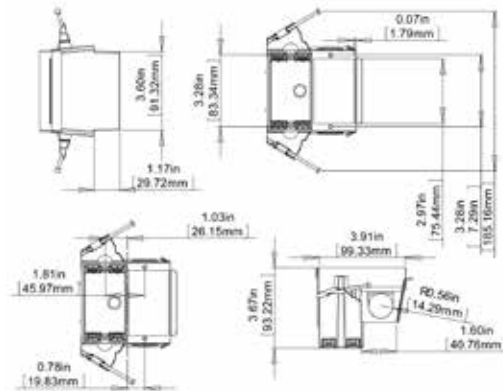

Two Gang Bracket with Nails

Part Number	Carton Quantity	Width	Height	Depth
EZLV2-NWN	24	4.10	3.75	3.13

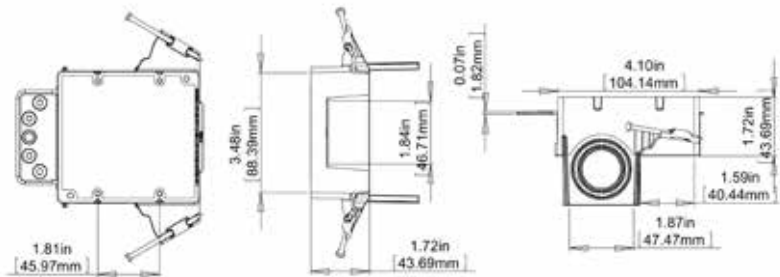

Low Voltage Divider

Part Number	Carton Quantity
EZLV2-SW	50



Use with Multi-gang new work and old work Heavy Wall switch/outlet boxes to install communication device and standard electrical switch or receptacle in a shard wall box.

EZ BOX® Residential Switch/Outlet Boxes

EZ Box® Four Square Nonmetallic Box - 18 Cubic Inch



Enhanced angled nails for quick mounting between studs or use the flange mounting molded with the box.

Eight clamps

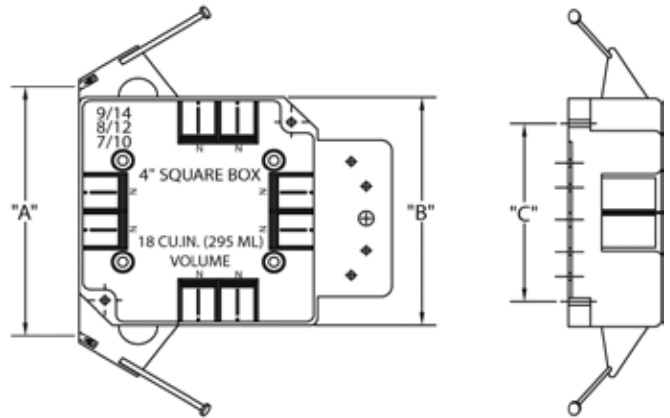

18 Cubic Inch

Part Number	Carton Quantity	"A"	"B"	"C"
EZ18XN	75	4.438	4.000	3.375

Dimensions are nominal

EZ Box® Four Square Nonmetallic Box - 32 Cubic Inch



Enhanced angled nails for quick mounting between studs.

Ten clamps

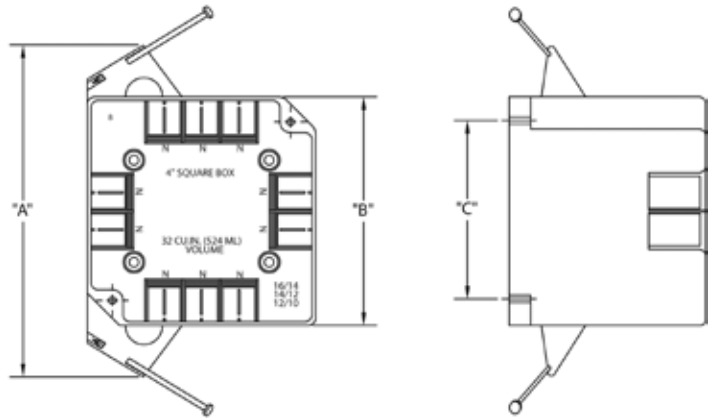

32 Cubic Inch

Part Number	Carton Quantity	"A"	"B"	"C"
EZ32XN	50	6.125	4.000	4.750

Dimensions are nominal

EZ BOX® Residential Switch/Outlet Boxes

Shallow EZ Box® - Bracketed

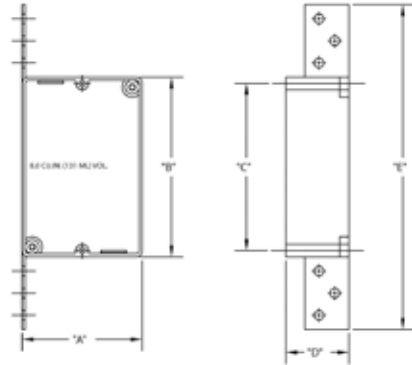

8 Cubic Inch

Part Number	Carton Quantity	"A"	"B"	"C"	"D"	"E"
EZ08SB	25	2.375	3.563	3.313	1.250	6.438

Dimensions are nominal

Shallow EZ Box® - Flanged (Old Work)

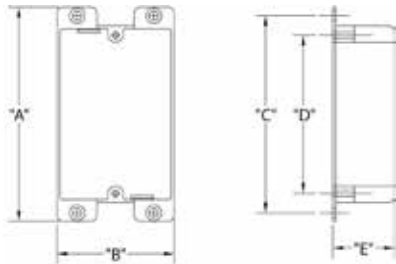

8 Cubic Inch

Part Number	Carton Quantity	"A"	"B"	"C"	"D"	"E"
EZ08SF	25	4.250	2.375	3.875	3.250	1.250

Dimensions are nominal

EZ Box® Nonmetallic Communications Box

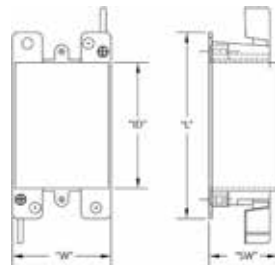

Part Number	Carton Quantity	"L"	"W"	"SW"	"ID"
EZ10SOLV	25	4.125	.125	1.563	2.875

Dimensions are nominal

EZ BOX® Residential Ceiling Boxes

EZ BOX® Nonmetallic Ceiling Boxes

- Enhanced angled nails for quick mounting between studs.
- Six clamps
- 2 hour fire rated
- Maximum fixture weight = 50 pounds
- Not for installation of ceiling fan

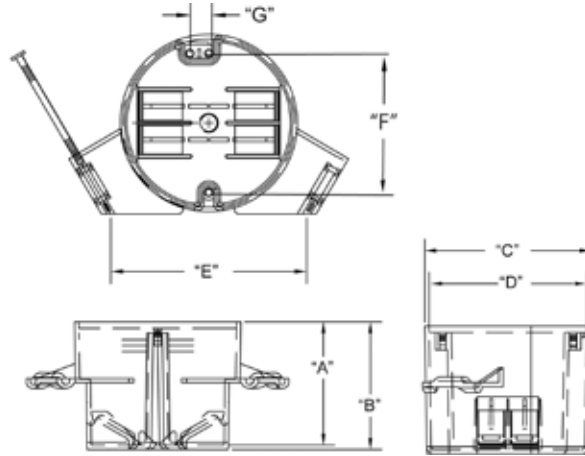

18 Cubic Inch

Part Number	Carton Quantity	"A"	"B"	"C"	"D"	"E"	"F"	"G"
EZ18CN	75	2.590	2.680	3.500	3.330	.388	2.750	.380

Dimensions are nominal

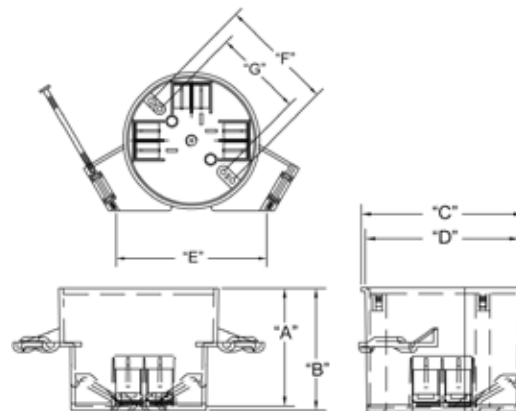

20 Cubic Inch

Part Number	Carton Quantity	"A"	"B"	"C"	"D"	"E"	"F"	"G"
EZ20CN	75	2.230	2.300	3.500	2.830	3.830	3.500	2.750

Dimensions are nominal

EZ BOX® Residential Ceiling Boxes

EZ BOX® Nonmetallic Ceiling Boxes with Ground Lug

Enhanced angled nails for quick mounting between studs.
 Six clamps
 2 hour fire rated
 Maximum fixture weight = 50 pounds
 Not for installation of ceiling fan

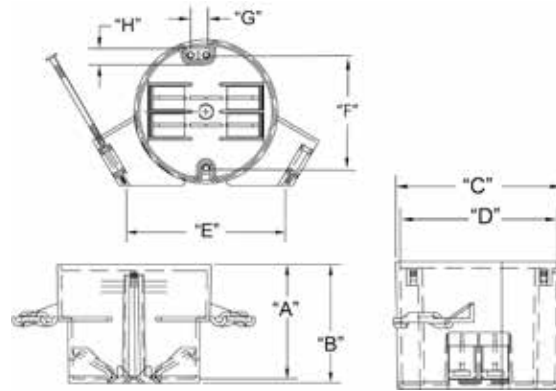

18 Cubic Inch

Part Number	Carton Quantity	"A"	"B"	"C"	"D"	"E"	"F"	"G"	"H"
EZ18CNG	75	2.590	2.680	3.500	3.330	.388	2.750	.380	.440

Dimensions are nominal

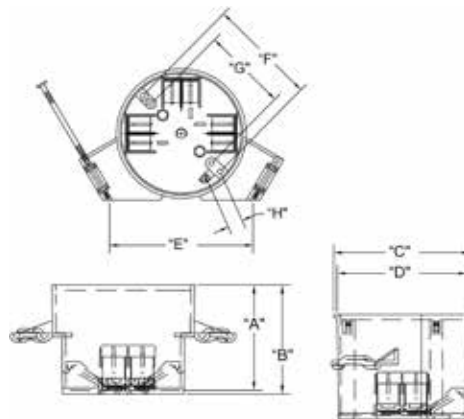

20 Cubic Inch

Part Number	Carton Quantity	"A"	"B"	"C"	"D"	"E"	"F"	"G"	"H"
EZ20CNG	75	2.230	2.300	3.500	2.830	3.830	3.500	2.750	.450

Dimensions are nominal

EZ BOX® Residential Ceiling Boxes

EZ BOX® Nonmetallic Ceiling Boxes with Bar Hanger

Enhanced angled nails for quick mounting between studs.
 Six clamps
 2 hour fire rated
 Maximum fixture weight = 50 pounds
 Not for installation of ceiling fan

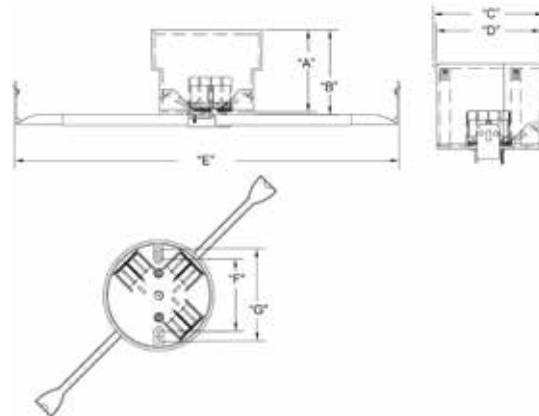
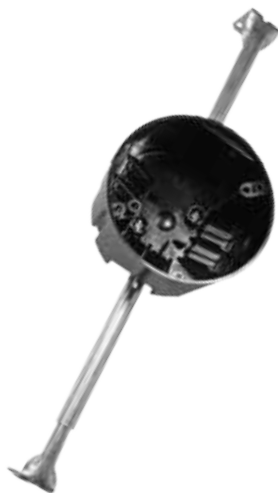

20 Cubic Inch



Part Number	Carton Quantity	"A"	"B"	"C"	"D"	"E"	"F"	"G"
EZ20CH	75	2.230	2.300	3.500	2.260	14 to 23	2.750	3.500

Dimensions are nominal

EZ BOX® Nonmetallic Ceiling Boxes with Bar Hanger and Ground Lug

Enhanced angled nails for quick mounting between studs.
 Six clamps
 2 hour fire rated
 Maximum fixture weight = 50 pounds
 Not for installation of ceiling fan

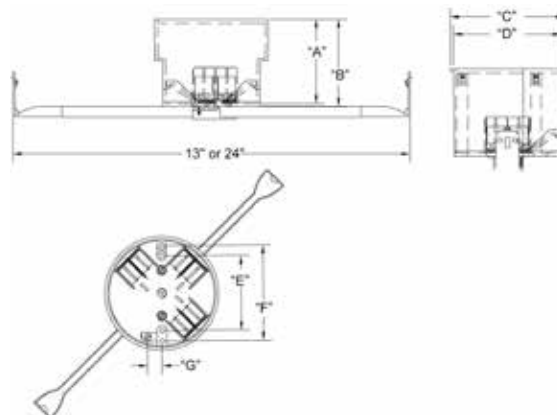
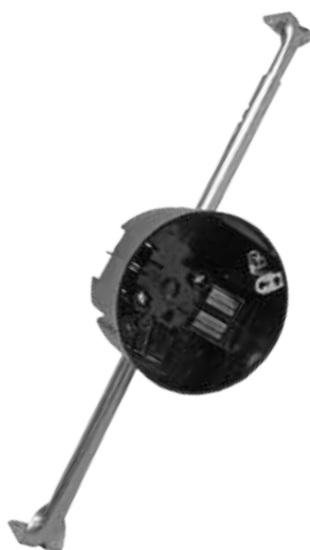

20 Cubic Inch



Part Number	Carton Quantity	"A"	"B"	"C"	"D"	"E"	"F"	"G"
EZ20CHG	75	2.230	2.300	3.500	2.260	2.750	3.500	.440

Dimensions are nominal

EZ BOX® Residential Alarm Boxes

EZ BOX® Nonmetallic EZ Box® Red Alarm Ceiling Boxes

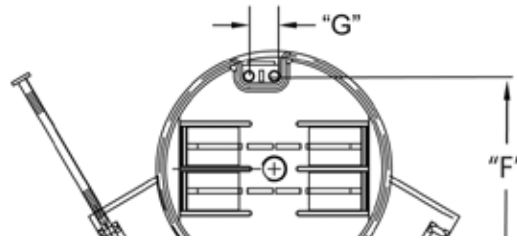

18 Cubic Inch

Part Number	Carton Quantity	"A"	"B"	"C"	"D"	"E"	"F"	"G"
EZ18CNA	75	2.590	2.680	3.500	3.330	.388	2.750	.380

Dimensions are nominal

For fire alarm or smoke detector installations. Red in color for easy identification. Nails angled for quick mounting between rafters.

2 hour fire rated
Maximum fixture weight = 50 pounds
Not suitable for ceiling fan installation.

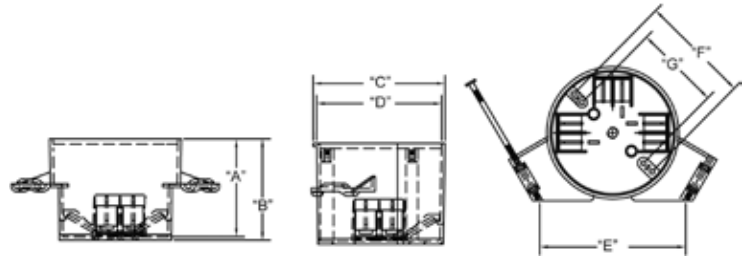

20 Cubic Inch

Part Number	Carton Quantity	"A"	"B"	"C"	"D"	"E"	"F"	"G"
EZ20CNA	75	2.230	2.300	3.500	2.830	3.830	3.500	2.750

Dimensions are nominal

EZ BOX® Red Single Gang Alarm Box

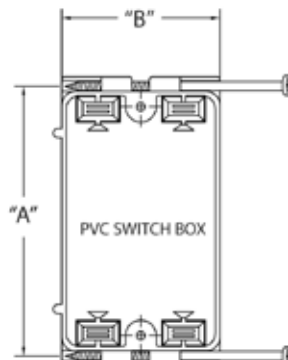

18 Cubic Inch

Part Number	Carton Quantity	"A"	"B"	"C"
EZ18SNA	100	3.875	2.250	2.875

Dimensions are nominal

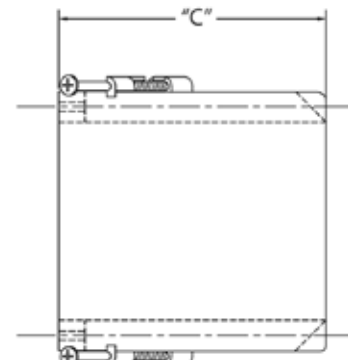

20.3 Cubic Inch

Part Number	Carton Quantity	"A"	"B"	"C"
EZ20SNA	100	3.875	2.250	3.125

Dimensions are nominal

Four knockouts

For fire alarm or smoke detector installations. Red in color for easy identification. Nails are angled for quick mounting between studs.

2 hour fire rated



23 Cubic Inch

Part Number	Carton Quantity	"A"	"B"	"C"
EZ23SNA	100	3.875	2.259	3.500

Dimensions are nominal

EZ Box® Residential Ceiling Fan Boxes

EZ BOX® Nonmetallic Ceiling Fan Boxes



Accommodates 3-1/2" and 2-9/16" mounting. Supports up to 70 lbs. fan weight or 200 lbs. fixture weight

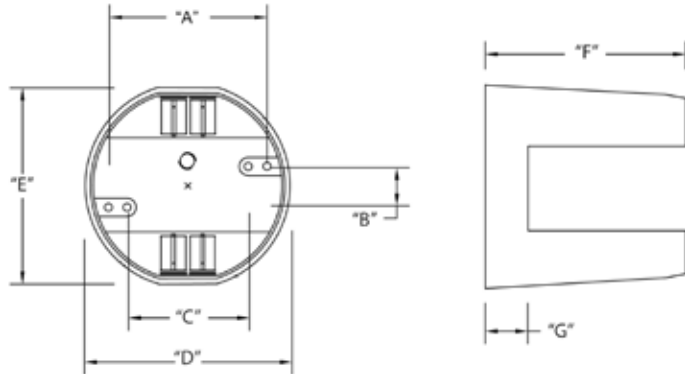

12 Cubic Inch

Part Number	Carton Quantity	"A"	"B"	"C"	"D"	"E"	"F"	"G"
EZ12CF	24	3.063"	1.063"	2.500"	4.000"	3.875"	2.625"	.500"

Dimensions are nominal



Supports up to 35 lbs. fan weight or 50 lbs. fixture weight.

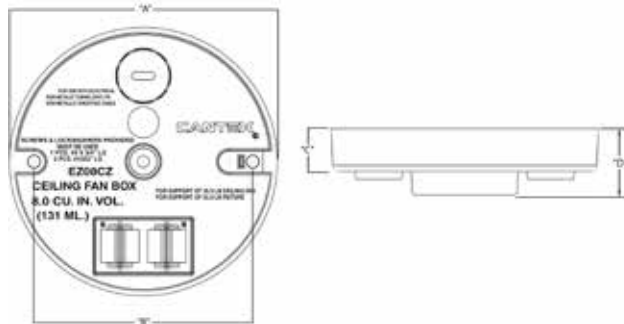

8 Cubic Inch

Part Number	Carton Quantity	"A"	"B"	"C"	"D"
EZ08CZ	25	4.250	3.500	.688	1.000

Dimensions are nominal



Supports up to 35 lbs. fan weight or 50 lbs. fixture weight.

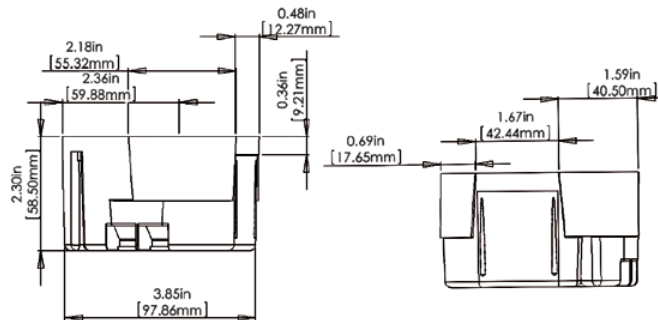

20 Cubic Inch Ceiling Fan Box

Part Number	Carton Quantity	Width	Height	Depth
EZ20CZ	18	4.00	4.00	2.30

EZ BOX® Residential Old Work Switch/Outlet Boxes

EZ BOX® Single Gang Old Work Residential Box



Four knockouts
2 EZ Mount retainers
2 hour fire rated

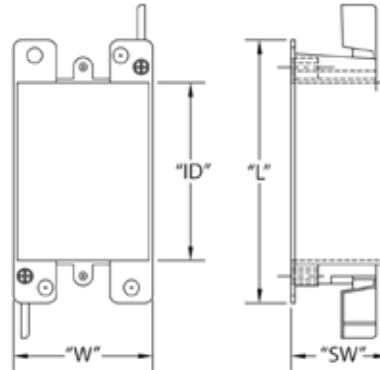

14 Cubic Inch

Part Number	Carton Quantity	"L"	"W"	"SW"	"ID"
EZ14SO	50	4.063	2.250	1.563	2.875

Dimensions are nominal



Four clamps
2 EZ Mount retainers
2 hour fire rated

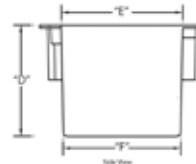
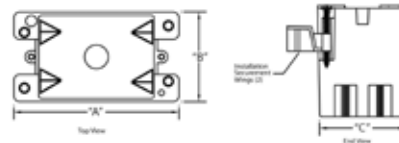

21 Cubic Inch

Part Number	Carton Quantity	"A"	"B"	"C"	"D"	"E"	"F"
EZ21SO	50	4.100	2.300	2.200	3.700	3.500	3.000

Dimensions are nominal

EZ BOX® Single Gang Heavy Wall Old Work Residential Box



Four clamps
2 EZ Mount retainers

18 Cubic Inch

Part Number	Carton Quantity	Width	Height	Depth
EZ18SO-HW	36	2.54	3.28	3.50

EZ BOX® Residential Old Work Switch/Outlet Boxes

EZ BOX® Two Gang Residential Old Work Box



Six knockouts
2 EZ Mount retainers
2 hour fire rated

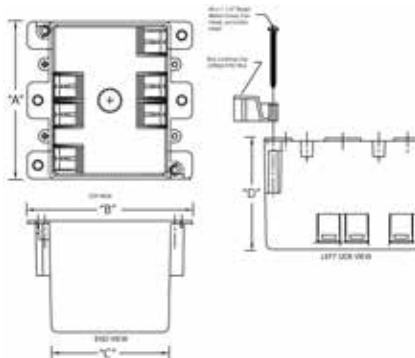

25 Cubic Inch

Part Number	Carton Quantity	"A"	"B"	"C"	"D"
EZ25DO	50	4.000	4.188	2.938	2.875

Dimensions are nominal

EZ BOX® Two Gang Residential Heavy Wall Old Work Box



Eight clamps
2 EZ Mount retainers
2 hour fire rated

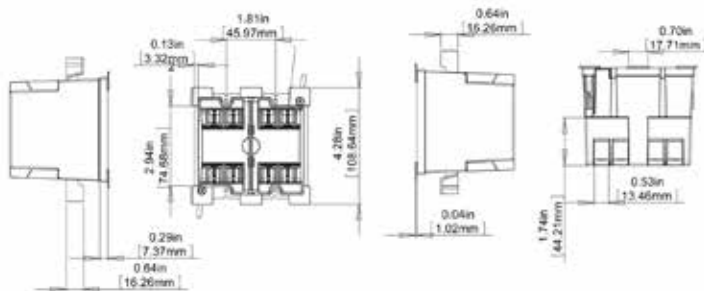

18 Cubic Inch

Part Number	Carton Quantity	Width	Height	Depth
EZ34DO-HW	18	4.13	3.63	3.50

EZ BOX® Residential Old Work Switch/Outlet Boxes

EZ BOX® Three Gang Residential Old Work Box

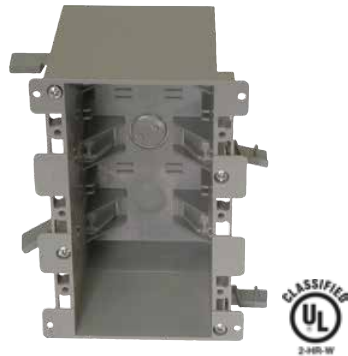

Six clamps
2 EZ Mount retainers
2 hour fire rated

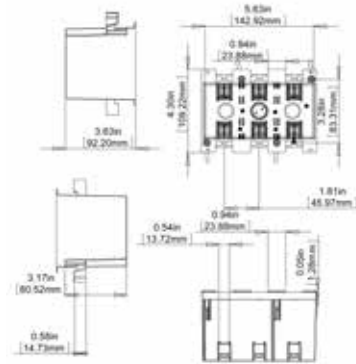

55 Cubic Inch

Part Number	Carton Quantity	Width	Height	Depth
EZ55TO	6	5.94	3.44	3.50

EZ BOX® Four Gang Residential Old Work Box

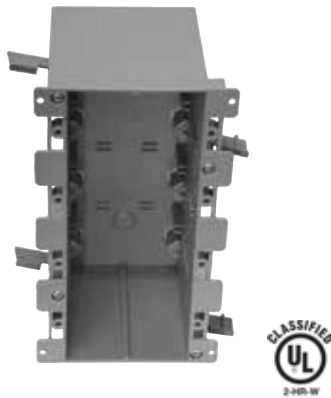

Eight clamps
2 EZ Mount retainers
2 hour fire rated

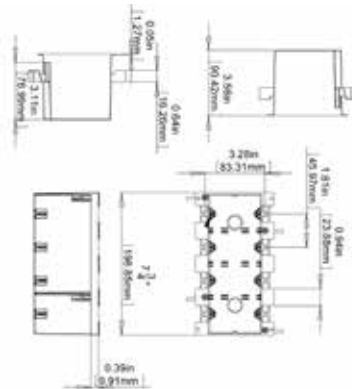

68 Cubic Inch

Part Number	Carton Quantity	Width	Height	Depth
EZ68QO	6	7.75	3.44	3.50

EZ BOX® Switch & Outlet Box Extender

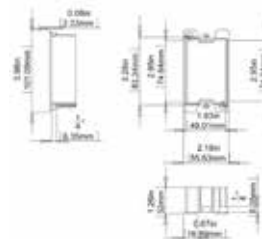

Part Number	Carton Quantity	Width	Height	Depth
EZSO-EXT	25	2.25	3.25	1.50

EZ BOX® Residential Old Work Ceiling Boxes

EZ BOX® Round Old Work Residential Box

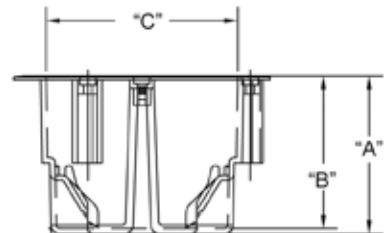
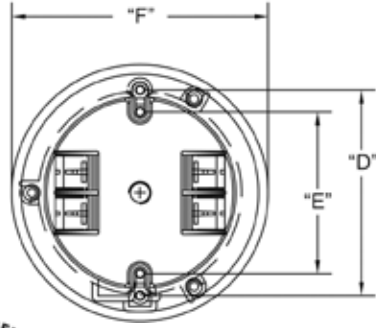

Four knockouts
 3 EZ Mount retainers
 2 hour fire rated
 Maximum fixture weight = 6 pounds
 Not suitable for fixture support or ceiling fan installation.

18 Cubic Inch

Part Number	Carton Quantity	"A"	"B"	"C"	"D"	"E"	"F"
EZ18CO	100	2.680	5.600	3.250	3.500	2.750	4.400

Dimensions are nominal

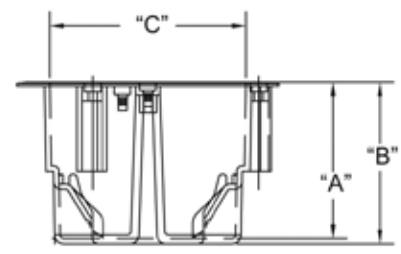
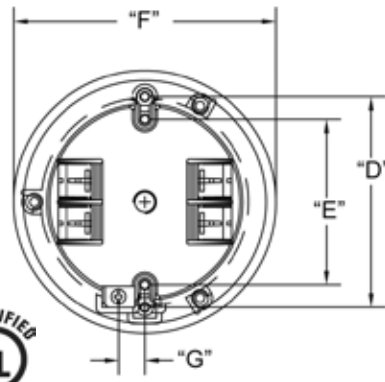

Four knockouts
 3 EZ Mount retainers
 2 hour fire rated
 Maximum fixture weight = 6 pounds
 Not suitable for fixture support or ceiling fan installation.

18 Cubic Inch with Ground Lug

Part Number	Carton Quantity	"A"	"B"	"C"	"D"	"E"	"F"	"G"
EZ18COG	100	2.680	5.600	3.250	3.500	2.750	4.400	.500

Dimensions are nominal

EZ Box® Residential Boxes Blank Covers

EZ BOX® Nonmetallic Electrical Blank Covers

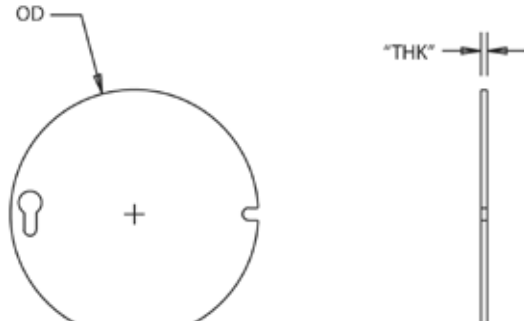

4" Round Blank Cover



Part Number	Carton Quantity	"OD"	"THK"
EZYKL	100	4.000"	.125"

Dimensions are nominal

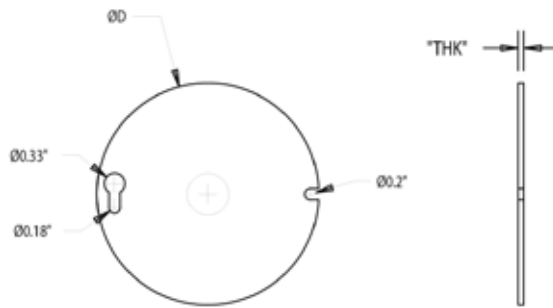

4" Round Blank Cover with 1/2" Knockout



Part Number	Carton Quantity	"OD"	"THK"
EZYL1	100	4.000	.125

Dimensions are nominal

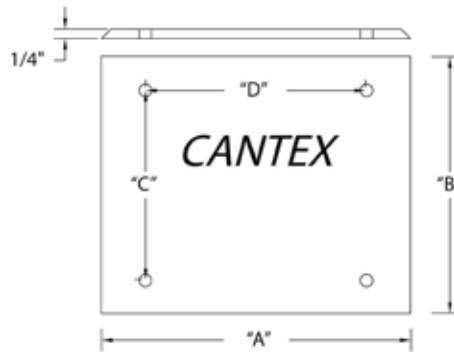
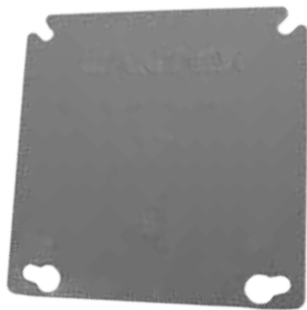

4" Two Gang Blank Cover



Part Number	Carton Quantity	"A"	"B"	"C"	"D"
EZXKL	100	4.875	4.875	3.250	3.500

Dimensions are nominal

EZ BOX® Residential Boxes

EZ BOX® Nonmetallic Electrical Plaster Ring

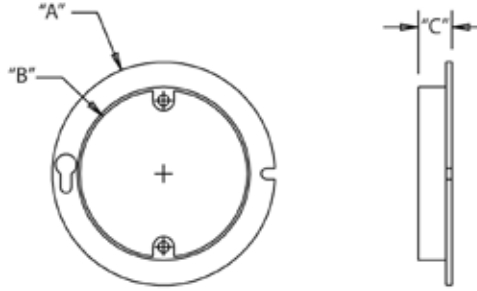

4" Round Plaster Ring

Part Number	Rise	Carton Quantity	"A"	"B"	"C"
EZ03YC	1/2"	100	4.000	3.000	.500
EZ04YC	5/8"	100	4.000	3.000	.625

Dimensions are nominal

EZ BOX® Nonmetallic Electrical Covers with Riser

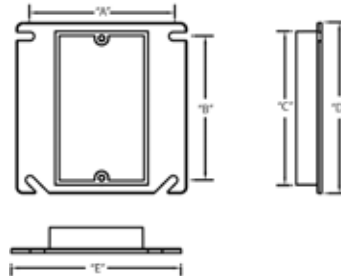

Single Gang Cover with Riser

Part Number	Rise	Carton Quantity	"A"	"B"	"C"	"D"	"E"
EZ03SXA	1/2	100	3.438	3.375	3.625	4.000	4.000
EZ04ES	5/8	50	3.438	3.375	3.625	4.000	4.000
EZ05ES	3/4	50	3.438	3.375	3.625	4.000	4.000
EZ06ES	1	40	3.438	3.375	3.625	4.000	4.000
EZ08ES	1-1/4	30	3.438	3.375	3.625	4.000	4.000

Dimensions are nominal

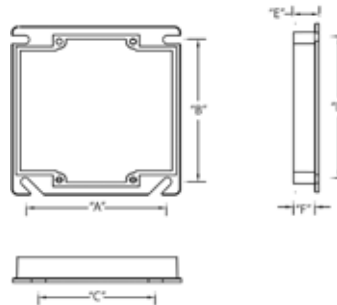

Two Gang Cover with Riser

Part Number	Rise	Carton Quantity	"A"	"B"	"C"	"D"	"E"	"F"
EZ06DXA	1/2	75	3.313	3.375	2.750	3.375	.625	.500
EZ08ED	5/8	50	3.375	3.375	3.360	3.580	.725	.625
EZ09ED	3/4	50	3.375	3.375	3.360	3.586	.850	.750

Dimensions are nominal

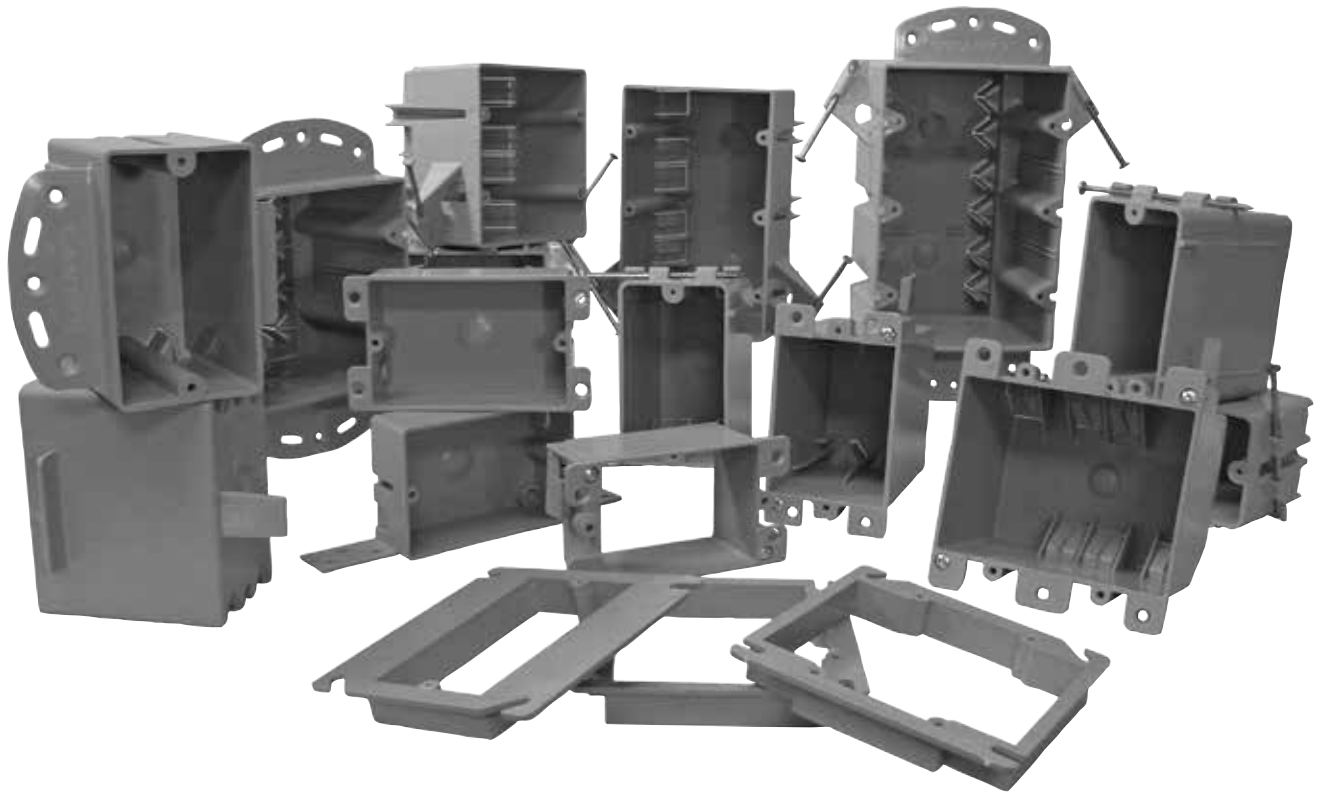

CANTEX EZ BOX® CROSS REFERENCE



CANTEX PART NO	DESCRIPTION	T&B / CAR-LON PART NO.	T&B / BOWERS PART NO.	T&B / CHALLENGER PART NO.	ALLIED PART NO.	RACO PART NO.	SLATER (P&S) PART NO.	THEPITT PART NO.
EDV2B	2 G NW DUAL VOLTAGE BRACKET W/NAILS	SC200DV						
EN16SB	16 CU IN 1 G NW ENT BOX W/1/2" CONCENTRIC KO'S	A58381D						
EN18SB	18 CUBIC INCH SINGLE GANG ENT BOX	A58381D/				7050		
EN20CB	20.3 CUBIC INCH ENT CEILING BOX	A615DE				7052		
EN20CB	20.5 CU IN 4" ENT OCTAGON NW CEILING BOX 1/2 - 3/4 KO	A615DE						
EN20CBL	20.5 CU IN 4" ENT OCTAGON NW CEILING BOX 1/2 - 3/4 KO WITH BRACKET	A615DL						
EN20CH	20.3 CUBIC INCH ENT CEILING BOX WITH HANGER	A615DH				7051		
EN20DB	4" SQUARE NW 20 CU IN OUTLET BOX W/ 1/2 & 3/4 CONCENTRIC KO'S	A521DE						
EN22DB	22.5 CUBIC INCH 2 GANG ENT BOX	AA521DE				7053		
EN22DB	22 CU IN 1 G NW ENT BOX W/1" CONCENTRIC KO'S	A122						
EN31DB	31 CUBIC INCH 2 GANG ENT BOX	A5217DE				7054		
EN38DB	38 CU IN 4" SQUARE NW ENT OUTLET BOX W/CONCENTRIC KO'S	A238						
EZ03SXA	4" SQUARE SINGLE GANG SQUARE COVER W/1/2" RISER	A410	4S-1G	*4042-12		7772	RC1	1010
EZ03YC	4" ROUND PLASTER RING WITH 1/2" RISER	A471						
EZ04ES	4" SQUARE SINGLE GANG COVER WITH 5/8" RISER	A411				7071		
EZ04YC	4" ROUND PLASTER RING WITH 5/8" RISER	A472					4SP2-31R	
EZ06ES	4" SQUARE SINGLE GANG COVER WITH 3/4" RISER	A412						
EZ06DXA	4" SQUARE 2 GANG COVER WITH 1/4" RISER							
EZ06DXA	4" SQUARE 2 GANG SQUARE COVER W/1/2" RISER	A420	4S-2G	*4022-12		7778		
EZ06ES	4" SQUARE SINGLE GANG COVER WITH 1" RISER	A413						
EZ08ED	4" SQUARE 2 GANG COVER WITH 5/8" RISER	A421				7076		
EZ08ES	4" SQUARE SINGLE GANG COVER WITH 1 1/4" RISER	A414						
EZ08SB	8 CUBIC INCH BRACKETED SHALLOW BOX	B108B						
EZ08SF	8 CUBIC INCH FLANGED SHALLOW BOX	B108R						
EZ09ED	4" SQUARE 2 GANG COVER WITH 3/4" RISER	A422					4SP1-214	
EZ12SO	12 CU IN 1 GANG PVC HANDY BOX	B112HB			9318			
EZ14SO	14 CUBIC INCH SINGLE GANG OLD WORK BOX	B114R	114-0W	6070-4	9363-EW	7887	S1-18-W	1680
EZ16SN	16 CUBIC INCH SINGLE GANG NAIL-ON BOX	B116A	116N	SN-16	1085-N	7355	P1-16-R	
EZ18CN	18 CUBIC INCH CEILING BOX 3/0 NAIL-ON	B518A	3R-16N	3090-N	9355-NC2	7118	C1-18-RAC	16310
EZ18CNG	18 CUBIC INCH CEILING BOX 3/0 NAIL-ON W/GRD LUG	B518P	3R-16NGP	3090-N-40	9335-NGC2	7918	C1-19-RGAC	16311
EZ18CO	18 CUBIC INCH OLD WORK CEILING BOX	B618R						
EZ18COG	18 CUBIC INCH OLD WORK CEILING BOX W/GRD LUG							
EZ18SN	18 CUBIC INCH SINGLE GANG NAIL-ON BOX	B118A	118N	SN-18	1086-N	7302	P1-18-R	1800
EZ18SO-HW	18 CU IN 1 G OW HARD BOX W/MOUNTING EARS & SWING CLAMPS	BH118R			9368-EW			
EZSL-GFCI	HANDY BOX COVER - GFCI	HB1GF						
EZSL-TGL	HANDY BOX COVER - TOGGLE SWITCH	HB1SW			9319			
EZKXL	4" SQUARE 2 GANG BLANK COVER	A400	4S-B	*4041/45PB	9344			
EZYKL	4" ROUND BLANK COVER	E460						
EZY1I	4" ROUND BLANK COVER WITH KNOCKOUT	A470D				7081		

CANTEX PART NO	DESCRIPTION	T&B / CARLON PART NO.	T&B / BOWERS PART NO.	T&B / CHALLENGER PART NO.	ALLIED PART NO.	RACO PART NO.	SLATER (P&S) PART NO.	THEPITT PART NO.
EZ18XN	18 CUBIC INCH 4 SQUARE SHALLOW NAIL-ON BOX	B418A		SN-418	9340-C2	7218	S442-IRAC	1900
EZ200CH	20 CUBIC INCH CEILING BOX W/14 1/4" - 23 1/2" HANGER	B620H	4R-20BH	4070-94	9350-24C2	7335	S1-20-HAC	16117/ 16122
EZ200CHG	20 CUBIC INCH CEILING BOX W/4 1/4"-23 1/2" HANGER WITH GROUND LUG	B620HG	4R-20BHGP	4070-94-40	9350-24GC2	7935	S1-20-HGAC	16118/ 16123
EZ200CN	20 CUBIC INCH CEILING BOX 40 NAIL-ON	B520A	4R-20N	4170-C	9351-NC2	7163	A1-20-RAC	
EZ200CNG	20 CUBIC INCH CEILING BOX 40 NAIL ON W/GRD LUG	B520P	4R-20NGP	4170-C-40	9351-NGC2	7823	S1-20-RGAC	16110
EZ200CZ	20 CU IN 3 OR 4" NW HARD ROUND CEILING BOX DEEP RATED .35 LB FAN OR 50 LB FIXTURE	B720R-SHK			9350-KFR			
EZ200SN	20 CUBIC INCH SINGLE GANG NAIL-ON BOX	B120A	120N	1060	1088-N	7620		
EZ21SBZ-ADJ	21 CU IN 1 G NW ADJUSTABLE BOX	B121ADJ			SB-1			
EZ22SN-HW	22 CU IN 1 G NW HARD BOX W/NAILS	BH122A-UPC			1099-N			
EZ23SN	23 CUBIC INCH SINGLE GANG NAIL-ON BOX	B122A						
EZ23SN-RG	22.5 CU IN 1 G NW VAPOR TIGHT W/NAILS	FN-23			1099-NV			
EZ25CF-HW	25 CU IN 3 OR 4" NW HARD ROUND CEILING BOX .35 FAN OR 50 FIXTURE W/L BRACKET	BH425L			9351-NFRINKFR			
EZ25CHG-HW	25 CU IN 3 OR 4" ROUND NW CEILING BOX W/HANG BAR/GRD LUG	BH425HP			9350-1616GK			
EZ25CH-HW	25 CU IN 3 OR 4" ROUND NW CEILING BOX W/HANG BAR	BH425H			9350 - 1616K			
EZ25CNG-HW	25 CU IN 3 OR 4" NW HARD ROUND CEILING BOX W/GRD LUG 50 FIXTURE	BH425P						
EZ25CN-HW	25 CU IN 3 OR 4" NW HARD ROUND CEILING BOX W/NAILS RATED 50 LB FIXTURE	BH425A-UPC			9351-N			
EZ25DO	25 CUBIC INCH TWO GANG OLD WORK BOX	B225R		6062-4	9312-EWK		S2-32-W	3490
EZ26CN-RG	26 CU IN NW CEILING BOX VAPOR TIGHT W/NAILS V CLAMPS	FN-426-C-V			9351-NKV		P2-35-RAC	3600
EZ32DN	32 CUBIC INCH TWO GANG NAIL-ON BOX	B232A	234N	SN-232	2300-NC4	7835		
EZ32XN	32 CUBIC INCH 4 SQUARE DEEP NAIL-ON BOX	B432A	45-32N	4000N	9343-NC2	7234	S44-35-FAC	
EZ34DBZ-ADJ	34 CU IN 2 G NW ADJUSTABLE BOX	B234DJC			SB-2			
EZ34DO-HW	34 CU IN 2 G OW HARD BOX W/MOUNTING EARS & SWING CLAMPS	BH234R			9329-EVIEWWK			
EZ35DN-HW	35 CU IN 2 G NW HARD BOX W/NAILS	BH235A			2300-NINK			
EZ36DN-RG	36 CU IN 2 NW G VAPOR TIGHT W/NAILS	FN-236-V			2302-NKV			
EZ44TN	44 CUBIC INCH THREE GANG NAIL-ON BOX	B344A	345N	1043-C	3300-NC6	7846	S3-54-RAC	4600
EZ53TN-HW	53 CU IN 3 G NW HARD BOX W/ NAILS	BH353A			3303-NINK			
EZ54TN-RG	54 CU IN 3 G NW VAPOR TIGHT W/NAILS	FN-354-V			3303-NKV			
EZ55QNB	55 CUBIC INCH FOUR GANG NAIL ON & BRACKET	B455A	4605B	7074-BH	3300-NBC4	7644	S468-RAC	6100
EZ55TO	55CU IN OW W/MOUNTING EARS & SWING CLAMPS	B355R			9313-EWK			
EZ64QN-HW	64 CU IN 4 G NW HARD BOX W/NAILS AND SUPPORT FLANGE	BH464A			4304-NINR			
EZ68QN	68 CU IN OW W/MOUNTING EARS & SWING CLAMPS	B468R			9314-EWK			
EZLV1-NWN	1 G NW LOW VOLTAGE BRACKET W/NAILS	SC100A						
EZLV1-OW	1 G OW LOW VOLTAGE BRACKET	SC100RR						
EZLV2-NWN	2 G NW LOW VOLTAGE BRACKET W/NAILS	SC200A						
EZLV2-OW	2 G OW LOW VOLTAGE BOX	SC200RR						
EZLVD-SW	NW LOW VOLTAGE DIVIDER PLATE	SCDIV						
EZLVS	1 G NW OR OW ADD ON BRACKET	SC100SC						
EZ50-EXT	1 G OW BOX EXTENDER	B1EXTB						
EZSL-BLANK	HANDY BOX BLANK COVER	HB1BL				9322		
EZSL-DPLX	HANDY BOX COVER - DUPLICATION	HB1DP				9320		

Installation Guidelines

Engineering & Design Information

Product Warranty

Authorized Distributor Policy

Conduit Installation Guidelines

Scope: For the purpose of general use and installation information, conduit is defined as a PVC tube in nominal sizes of ½” through 6”, to be used in non-pressure applications to provide containment of raceways for electrical power wire and cable, communications wiring or fiber optic cables. Conduit products are not intended for the transport of potable water, sewage or drain water, air or other gases or corrosive liquids.

1.0 Transportation, Handling and Storage

1.1 Transportation: **CANTEX** conduit should be transported in modules or bundles in a straight and level position. When possible, larger diameter and heavy walled conduit should be loaded first on the truck or trailer when multiple modules must be loaded. Each vertical stack of modules should be secured with at least two nylon straps or slings at least 4” in width with only enough tightening pressure on the straps to ensure a secure load. Chains and metal strapping should be avoided to secure conduit loads to the transporting vehicle.

1.2 Handling: Conduit should be unloaded one module at a time with a fork lift or backhoe equipped with forks. If unloaded using slings, two slings should be used and positioned so that the center of gravity of the module is centered on the lifting equipment. Personnel on the ground around the unloading site should be kept clear of the load to prevent injury in the event of an equipment failure or shifting of the load. Do not push modules from the vehicle to the ground as damage to the conduit may result. Do not break bundles on the vehicle and allow the conduit to fall to the ground as personal injury or product damage may result.

1.3 Storage: Conduit should be stored in a straight and level position and stacks should not exceed 8 feet in height. Thin walled conduit or small modules of conduit should not be stacked over 6 feet in height. For short-term storage (up to 6 months), the conduit need not be covered for sunlight damage protection. For altitudes of 3-4,000 feet and longer term storage, coverage with an opaque tarp or UV resistant sheeting should be considered to prevent fading or color changing from UV exposure. The storage site should be as free as possible from dirt, dust or other airborne contaminants. The ends of the conduit modules should not be covered in order to allow air passage and prevent heat buildup within the modules. Internal module temperatures should not exceed 140°F. (60°C)

2.0 Installation

2.1 Preparation: The conduit should be clean and dry before installation is attempted. Dirt and dust or other contaminants should be wiped clean from the bell and spigot joint areas. When possible, the conduit temperature should be normalized to the ambient temperature or the expected service environment temperature before installation in order to minimize expansion or contraction difficulties with the project.

2.2 Cutting: PVC conduit should be cut to length using a hacksaw, fine toothed saw or a rotating pipe cutter. Rigid, smooth walled conduit up through 1” may be successfully cut with a shear type cutting tool. Corrugated EZ FLEX® ENT, Opti-Flex fiber optic conduit and Enviro-Flex liquid tight flexible conduit may also be cut with a knife or shear-type cutter. Larger pipe may require the use of a miter box to ensure square cuts. All cuts should be clean and square with the barrel of the conduit. Cut ends should be de-burred with a pocket knife or rasp with no burrs remaining on the O.D. and I.D. of the conduit. A slight chamfering of the O.D. or I.D. cut end may be desirable to facilitate joining or to prevent cable damage and to facilitate rope pulling through the conduit.

3.0 Solvent Cement Joints

CAUTION: ALL PVC CEMENTS ARE HIGHLY FLAMMABLE AND SHOULD BE CONSIDERED AS HAZARDOUS MATERIALS. AVOID USING IN THE PRESENCE OF OPEN FLAME, ELECTRICAL SPARKS, WELDING OR LIT SMOKING MATERIAL. AVOID BREATHING CONCENTRATED FUMES AND PROVIDE ADEQUATE VENTILATION IN CONFINED AREAS. READ AND FOLLOW ALL PRECAUTIONS ON THE CEMENT CONTAINER. MATERIAL SAFETY DATA SHEETS ARE AVAILABLE UPON REQUEST FROM CANTEX INC. TELEPHONE (817) 215-7000 OR ON-LINE AT www.cantexinc.com

Conduit Installation Guidelines

3.1 Joint Requirements: There are two types of bell fits, interference fit or clearance fit, depending on the specification of the conduit to be used. An “interference fit” means that the spigot will not dry fit to the base of the bell and will lodge about two-thirds deep into the bell. A clearance fit means that the spigot will slide all the way to the base of the bell without application of cement. Interference fits, therefore are tighter and provide watertight joints easily; clearance fits will leave small gaps between the inside of the bell and the spigot and may require extra in jointing if watertight joints are required.

3.2 Solvent Cement: Select the proper type of cement to fit the job requirements. The cement should meet the requirements of ASTM D 2564. Three types of cement are available, based on the viscosity, regular bodied, medium bodied and heavy bodied. Regular bodied cement, such as **CANTEX #99**, is suitable for most conduit applications up through 6” size.

For cement joints in corrugated ENT or corrugated fiber optic conduit, cement such as **CANTEX #50 ENT** cement should be used.

3.3 Solvent Cement Storage: Store sealed cement containers in temperature between 40°F (5°C) to 70°F (31°C) when not in use. Before use, check to see that the cement is fluid and not lumpy or gelled. If lumpy or gelled, discard the cement; do not attempt to liquefy or dilute with cement primer.

DO NOT USE OPEN FLAME OR ELECTRIC HEATERS TO WARM CEMENT.

3.4 Surface Preparation: Wipe joint surfaces clean of dirt, moisture or other contaminants. If the joining surfaces are extremely dirty or coated with oil, wipe thoroughly and do not attempt to make a cement application until all evidence of moisture is gone. Extremely hot jointing areas (90°F or above) should be cooled by shading or application of a damp cloth. If a damp cloth is used, area should be allowed to dry before applying cement. Hot surfaces dry the cement rapidly and can cause insufficient welding if liquid cement is not evident on the surface when the bell and spigot are joined. Use of a heavier, slower drying cement may be appropriate when it is impractical to cool the joints.

3.5 Application of Cement: For most conduit joints, a single application of cement on the spigot to a length equal to the bell depth is sufficient. On conduit of 1” or smaller, use a dauber applicator which is supplied in the lid of the cement container. On larger sizes, use a small natural bristle paint brush of a width approximately one-half the diameter of the pipe. (Example: For 4” pipe, use a 2” wide brush.) Apply the cement quickly and evenly around the spigot and insert into the bell or fitting while the cement is still liquid.

3.6 Makeup: Insert the spigot fully into the bell and apply a one-quarter twist on the spigot section as insertion is being made. Hold the joint firmly together for 10 to 20 seconds without movement. If the spigot section backs out upon release, pull the joint apart and reapply another coat of cement and reassemble and hold until the joint does not back out upon release. Cold weather applications may require a longer holding time. A small bead of cement should appear around the lip of the bell if adequate cement has been applied. Wipe off excess bead after the joint has set.

3.7 Set Time: Handle the newly assembled joints carefully until the cement has gone through an adequate set time. Recommended set time is related to temperature of the joint follows:

30 minutes minimum at 60 to 100°F ((15 to 40°C)

1 hour minimum at 40 to 60°F (5 to 15°C)

2 hours minimum at 20 to 40°F (-5 to 5°C)

4 hours minimum at 0 to 20°F (-20 to -5C)

Note: Joint damage or loosening may occur up to 48 hours after assembly in temperatures below 40°F if the joints are severely stressed.

4.0 Expansion and Contraction Considerations

Thermal expansion and contraction of the PVC conduit system must be considered in all projects. PVC conduit expands or contracts at a rate of 3×10^{-5} in./in./°F, or about 3/8" per 100 feet per 10°F temperature change. The total change in length of the conduit run can be calculated by the following equation:

(Eq.1) Length change, $L_c = C$ (Conduit Length, inches) (AT)
 Where: $C =$ Coefficient of Expansion = 3×10^{-5} in./in./°F
 $AT =$ Temperature change, °F
 $L_c = (.00003 \text{ in./in./°F}) (500 \text{ ft.})(12 \text{ in./ft.})(30^\circ) = 5.4 \text{ inches}$

The most common effect of expansion is to create unsightly warpage or sagging in the conduit run although larger conduit may create damage to the terminations. Contraction is usually more damaging than expansion as it can create joint separation or pullouts at the termination. Design consideration must be given to both conditions.

For underground installations, expansion or contraction can usually be accommodated by "snaking" the conduit in the trench. It is desirable to allow the conduit run to normalize with the ground temperature before backfilling or making end connections such as at a manhole. Once the pipe in a trench has normalized and is backfilled, expansion and contraction is minimized due to the relatively constant earth temperature and the friction of the soil on the conduit

In above ground installations, expansion/contraction can be accommodated by the use of change of direction fittings or by expansion joints. The conduit should be secured by hangers or straps which are tightened only to the point that slippage through the supports is possible. In long straight runs where bending or change of direction cannot be allowed and where the conduit ends must be securely terminated, expansion joints should be used (example: conduit suspended under a bridge). The number of expansion joints required can be calculated as follows:

1. Determine the total change in length, L_c , anticipated due to the maximum and minimum temperatures to when the conduit run will be exposed.
2. Use the following equation to determine the number of expansion joints required:
 Eq.2) $N = L_c / EA$ Where: $N =$ number of expansion joints required
 $EA =$ expansion allowance in each expansion joint

Install the expansion joints at equal intervals along the run. The movable section of the expansion joints must be set at the time of installation according to the installation temperature such that both expansion and contraction may be accommodated. Refer to the drawing shown below.

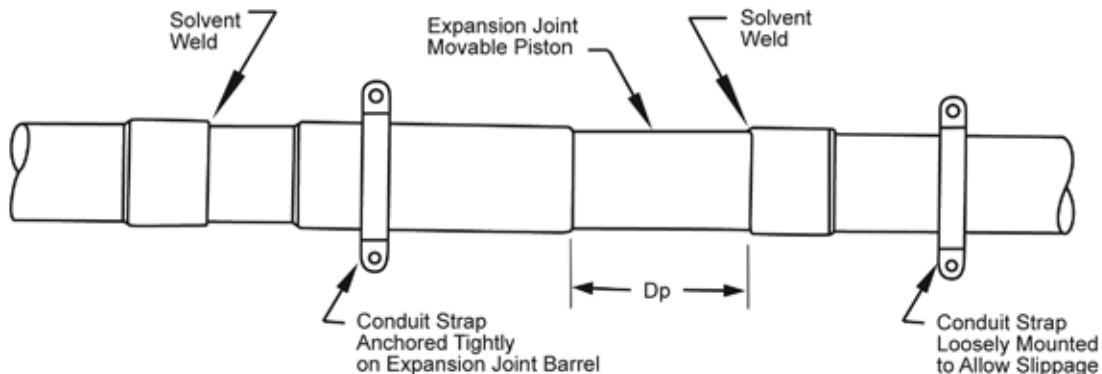

Conduit Installation Guidelines

The correct piston setting, Dp, can be determined for any installation temperature by using the following equation:

$$(Eq. 3) \quad Dp = ((T \text{ max}) / (+T) - (T \text{ installed}) / 2!) EA$$

Where: Dp = Distance of piston from fully closed position
 T max = Maximum temperature, °F, to which the conduit will be exposed
 T min = Minimum temperature, °F, to which the conduit will be exposed
 +T = T max - T min

EA = Expansion allowance, in inches, for each expansion joint

Example: A 500 ft. run of conduit will be installed under a bridge and exposed to a direct sunlight temperature of 140°F and winter temperature of 0°F.

a) Determine the total length change by Eq. 1:

$$Lc = (.00003)(500)(12)(140) = 25.2 \text{ inches}$$

b) Using an expansion joint that allows 3 inches of travel each way (total piston travel = 6 inches), determine the number of expansion joints required by Eq. 2:

$$N = 25.2 \text{ max} / 3 = 8.4 \text{ (Use 9 joints)}$$

c) If the conduit was installed at 80°F, determine the piston setting, Dp by Eq. 3:

$$Dp = ((140 - 80) / 140)(3) = 1.28 \text{ inches}$$

The nine expansion joints should be installed 50 feet apart in the conduit run with each expansion joint barrel tightened securely and rest of the hangers tightened loosely to allow slippage.

4.1 Expansion/Contraction in Concrete Encasement: When encased in concrete, PVC conduit is immobilized by the concrete and will expand and contract at the expansion coefficient rate of the concrete.

5.0 Support Spacing:

Supports for PVC conduit may be somewhat lighter than for metallic conduit due to its lighter weight. The following support chart is based on the National Electric Code, Table 347-8, assuming a maximum air temperature of 122°F (50°C) and conductor temperature of 194°F (90°C).

Conduit Size (Inches)	Maximum Spacing Between Supports (Feet)
1/2 thru 1	3
1-1/4 thru 2	5
2-1/2 thru 3	6
3-1/2 thru 5	7
6 thru 8	8

Latest NEC code and local codes are subject to change and should be consulted.

Conduit Installation Guidelines

6.0 Bending

One of the advantages of PVC conduit is the ability to easily make changes in direction by bending with the use of mechanical benders. In underground or above ground installations, the conduit path may be deviated to change directions or avoid obstacles. The following diagram and table offers a guideline to a safe allowance for bending in one ten foot section conduit. Conduit bent to these maximum allowances will have a maximum fiber stress of 2000 psi which is a safe level for non-pressure conduits. Bending beyond these values may result in buckling of the conduit. Force required for bending varies with the size of the conduit and temperature. For bends shorter than the minimum bending radius, R_b , it is recommended that factory made bends be used. These bends are available in 11-1/4°, 22-1/2°, 30°, 45° and 90° increments and are available from stock in standard radii. Special degree bends or special radii are available on request to **CANTEX** in most sizes. Special degree bends or special radii are available on request to **CANTEX** in most sizes.

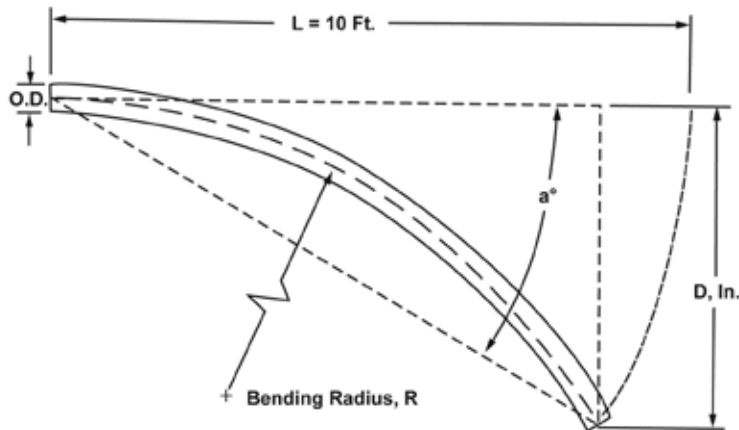

BENDING ALLOWANCE PER 10' LENGTH OF CONDUIT				
Conduit Size (Inches)	O.D.	R_b , Ft.	A°	Deflection D (Inches)
1/2	.840	9	33.0	61.4
3/4	1.050	11	26.0	51.1
1	1.315	14	21.0	41.9
1-1/4	1.660	17	16.5	33.7
1-1/2	1.900	20	14.5	29.7
2	2.375	25	11.6	23.9
2-1/2	2.875	30	9.6	19.9
3	3.500	36	7.9	16.4
3-1/2	4.000	42	6.9	14.3
*4	4.350	45	6.3	13.2
4	4.500	47	6.1	12.8
5	5.563	58	4.9	10.3
6	6.625	69	4.2	8.7
8	8.625	90	3.2	6.7

* Telephone Conduit

The radii of long curves using multiple joints of conduit should be limited to the values shown in the table for minimum radii. The joints to be bent should be allowed to thoroughly set (See Sec. 3.7) before bending and placement.

Conduit Installation Guidelines

7.0 Direct Burial

7.1 Trench Width: Trench width at the ground level may vary depending on soil types, equipment used, position of surface structures, etc. Where compacting of the initial backfill is required, the trench should be a minimum of 5 pipe diameters. In very wide trenches, sub-ditching should be considered to provide maximum side support for the conduit. Shoring or trench boxes should be used for workman protection in loose soil or very deep trenches.

7.2 Trench Bottom: The trench bottom should be constructed to provide a firm, stable and uniform support for the conduit for the full lengths of the conduit. Unless specified, line and grade is not required provided that the conduit will conform to the trench bottom and bending does not exceed the values given in Sec. 3.7. Large rocks and boulders, frozen lumps of soil, large lumps of clay, etc. should be removed before the conduit is installed. Rocky or uneven trench bottoms should be bedded with loose backfill or sand to provide a soft, even cushion for the conduit.

7.3 Initial Backfill: Initial backfill should be dry and free flowing and contain rock not to exceed 1" in. diameter. Initial backfill should be applied in light layers of 3" to 6" and spread uniformly. Tamping should be done layer by layer of initial backfill up to the springline of the conduit. In multiple conduit installations the initial backfill should be worked carefully between the ducts and under the haunches. Tamping should be done between the edges of the ditch over the springline of the conduit, but no tamping should be done over the top of the conduit. Initial backfill should be placed loosely over the top of the conduit to a depth of 6". All compaction by either tamping or flooding should be completed before the final backfill if placed.

7.4 Final Backfill: After placement and compaction of conduit embedded materials, the balance of backfill materials may be machine placed and should contain no large rocks or stones, frozen material or other debris. Proper compaction procedures should be exercised to provide required soil densities.

8.0 Concrete Encasement:

8.1 Tie and fasten all conduit to prevent floating. If concrete is required in the trench bottom, allow at least 2" freeboard between conduit and tie down equipment.

8.2 Spacers, if used, should be spaced at the intervals shown below or less.

Conduit Size Size (Inches)	Spacing (Feet)
½ thru 2	4 thru 6
3 thru 3 ½	5 thru 8
4 thru 8	6 thru 10

A 1" minimum spacing should be allowed for all conduit and a concrete mix using pea gravel should be used for encasement. If complete encasement is required at areas requiring bends in making freeway or water crossings, use a 2" minimum spacing.

8.3 Coverage: Minimum concrete coverage should be 2" on top, bottom and sides of conduit. Firm soil conditions may eliminate need for concrete at the trench bottom.

8.4 Backfilling: Backfilling can be done as soon as the concrete has cured to withstand the weight of a man.

8.5 Temperature Considerations: The temperature rise of the concrete as it cures may cause some expansion of the conduit. Concrete should be poured from the center of the run toward each free end or from one tie-in point toward the free end of the conduit. Make permanent terminal tie-ins after the temperature has normalized.

Conduit Engineering and Design Data

Schedule 40 and Schedule 80 Conduit - Approximate Weight per 10 Feet (Lbs.)

Nom. Size (Inch)	CANTEX Sch. 40	CANTEX Sch. 80	Aluminum	Electrical Metallic Tubing (EMT)	Intermediate Metal Conduit (IMC)	Rigid Steel (GALV)
1/2	16	21	27	30	57	79
3/4	22	28	36	78	78	105
1	32	41	53	112	112	153
1-1/4	44	57	70	114	114	201
1-1/2	52	69	86	176	176	246
2	77	105	116	230	230	334
2-1/2	122	160	183	270	393	527
3	159	215	239	350	483	690
3-1/2	191		288	400	561	831
4	227	311	340	--	625	982
5	307	437	468	--	--	1,344
6	400	600	612	--	--	1,770
8	600	--	--	--	--	--

Thermal Properties

	ASTM Test	Typical Values
Coefficient of Thermal Expansion, in./in./°F @ 73.4°F	D696	3.0 X 10 ⁻⁵
Heat Distortion °F at 264psi	D696	172°F
Thermal Conductivity BTU (hr)(ft ²)°F/in)	D648	1.3
Water Absorption % by weight	D570	1.03% max.

Mechanical Properties

	ASTM Test	Typical Values
Specific Gravity	D 792	1.42 - 160
Tensile Strength, psi @ 73.4°F	D 638	5 - 6,500
Izod Impact Ft. lbs./in. of notch	D 256	.65 - 1.5
Flexural Strength, psi	D 790	11,000
Compressive Strength psi	D 695	8,500
Hardness (Durometer D)	D 2240	77 min

Electrical Properties

	ASTM Test	Typical Values
Dielectric Strength Volts/Mil	D 149	1,100
Dielectric Constant 60 COS @30°C	D 150	4.5
Power Factor 60 CPS @ 30°C	D 150	1.9

Impedance (Volts lost per ampere per 100 ft.)

	30 90% P.F.	80% P.F.	10 90% P.F.	80% P.F.
Steel Conduit	.0118	.0123	.0136	---
PVC Conduit	.0105	.0106	.0121	.0122

Conduit Engineering and Design Data

Maximum Number of Conductors in Nonmetallic PVC Schedule 40 PVC Conduit

Table C.10 (Based on Table 1, Chapter 9 of the N.E.C.)

Conductor Size AWG, MCM		Conduit Trade Size										
		1/2"	3/4"	1"	1-1/4"	1-1/2"	2"	2-1/2"	3"	4"	5"	6"
14	THW	5	9	16	28	38	63	90	139	240	378	546
	THHN	11	21	34	60	82	135	193	299	517	815	1178
12	THW	4	8	12	22	30	50	72	112	193	304	439
	THHN	8	15	25	43	59	99	141	218	377	594	859
10	THW	3	6	10	17	24	39	56	87	150	237	343
	THHN	5	9	15	27	37	62	89	137	238	374	541
8	THW	1	3	6	10	14	23	33	52	90	142	205
	THHN	3	5	9	16	21	36	51	79	137	216	312
6	THW	1	2	4	8	11	18	26	40	69	109	157
	THHN	1	4	6	11	15	26	37	57	99	156	225
4	THW	1	1	3	6	8	13	19	30	51	81	117
	THHN	1	2	4	7	9	16	22	35	61	96	138
3	THW	1	1	3	5	7	11	16	25	44	69	100
	THHN	1	1	3	6	8	13	19	30	51	81	117
2	THW	1	1	2	4	6	10	14	22	37	59	85
	THHN	1	1	3	5	7	11	16	25	43	68	98
1	THW	0	1	1	3	4	7	10	15	26	41	60
	THHN	1	1	1	3	5	8	12	18	32	50	73
1/0	THW	0	1	1	2	3	6	8	13	22	35	51
	THHN	1	1	1	3	4	7	10	15	27	42	61
2/0	THW	0	1	1	1	3	5	7	11	19	30	43
	THHN	0	1	1	2	3	6	8	13	22	35	51
3/0	THW	0	1	1	1	2	4	6	9	16	25	36
	THHN	0	1	1	1	3	5	7	11	18	29	42
4/0	THW	0	0	1	1	1	3	5	8	13	21	30
	THHN	0	1	1	1	2	4	6	9	15	24	35
250	THW	0	0	1	1	1	3	4	6	11	17	25
	THHN	0	0	1	1	1	3	4	7	12	20	28
300	THW	0	0	1	1	1	2	3	5	9	15	21
	THHN	0	0	1	1	1	3	4	6	11	17	24
350	THW	0	0	0	1	1	1	35	5	8	13	19
	THHN	0	0	1	1	1	2	3	5	9	15	21
400	THW	0	0	0	1	1	1	3	4	7	12	17
	THHN	0	0	0	1	1	1	3	5	8	13	19
500	THW	0	0	0	1	1	1	2	3	6	10	14
	THHN	0	0	0	1	1	1	2	4	7	11	16
600	THW	0	0	0	0	1	1	1	3	5	8	11
	THHN	0	0	0	1	1	1	1	3	5	9	13
700	THW	0	0	0	0	1	1	1	2	4	7	10
	THHN	0	0	0	0	1	1	1	3	5	8	11

Conduit Engineering and Design Data

Maximum Number of Conductors in Nonmetallic PVC Schedule 80 PVC Conduit

Table C.9 (Based on Table 1, Chapter 9 of the N.E.C.)

Conductor Size AWG, MCM		Conduit Trade Size										
		1/2"	3/4"	1"	1-1/4"	1-1/2"	2"	2-1/2"	3"	4"	5"	6"
14	THW	4	8	13	23	32	55	79	123	215	341	490
	THHN	9	17	28	51	70	118	170	265	464	736	1055
12	THW	3	6	10	19	26	44	63	99	173	274	394
	THHN	6	12	20	37	51	86	124	193	338	537	770
10	THW	2	5	8	15	20	34	49	77	135	214	307
	THHN	4	7	13	23	32	54	78	122	213	338	485
8	THW	1	3	5	9	12	20	29	46	81	128	184
	THHN	4	7	13	23	32	54	78	122	213	338	485
6	THW	1	1	3	7	9	16	22	35	62	98	141
	THHN	1	3	5	9	13	22	32	51	89	141	202
4	THW	1	1	3	5	7	12	17	26	46	73	105
	THHN	1	1	3	6	8	14	20	31	54	86	124
3	THW	1	1	2	4	6	10	14	22	39	63	90
	THHN	1	1	3	5	7	12	17	26	46	73	105
2	THW	1	1	1	3	5	8	12	19	33	53	77
	THHN	1	1	2	4	6	10	14	22	39	61	88
1	THW	0	1	1	2	3	6	8	13	23	37	54
	THHN	0	1	1	3	4	7	10	16	29	45	65
1/0	THW	0	1	1	1	3	5	7	11	20	32	46
	THHN	0	1	1	2	3	6	9	14	24	38	55
2/0	THW	0	1	1	1	2	4	6	10	17	27	39
	THHN	0	1	1	1	3	5	7	11	20	32	46
3/0	THW	0	0	1	1	1	3	5	8	14	23	33
	THHN	0	1	1	1	2	4	6	9	17	26	38
4/0	THW	0	0	1	1	1	3	4	7	12	19	27
	THHN	0	0	1	1	1	3	5	8	14	22	31
250	THW	0	0	0	1	1	2	3	5	9	15	22
	THHN	0	0	1	1	1	3	4	6	11	18	25
300	THW	0	0	0	1	1	1	3	5	8	13	19
	THHN	0	0	0	1	1	2	3	5	9	15	22
350	THW	0	0	0	1	1	1	2	4	7	12	17
	THHN	0	0	0	1	1	1	3	5	8	13	19
400	THW	0	0	0	1	1	1	2	4	7	10	15
	THHN	0	0	0	1	1	1	3	4	7	12	17
500	THW	0	0	0	1	1	1	1	3	5	9	13
	THHN	0	0	0	1	1	1	2	3	6	10	14
600	THW	0	0	0	0	1	1	1	2	4	7	10
	THHN	0	0	0	0	1	1	1	3	5	8	12
700	THW	0	0	0	0	1	1	1	2	4	6	9
	THHN	0	0	0	0	1	1	1	2	4	7	10

Conduit Engineering and Design Data

Maximum Conductors in Nonmetallic PVC Schedule 80 PVC Conduit

Table C.9 (Based on Table 1, Chapter 9 of the N.E.C.)

Type Letters	Conductor Size AWG, kcmil	Conduit Trade Size (Inches)											
		1/2"	3/4"	1"	1-1/4"	1-1/2"	2"	2-1/2"	3"	3-1/2"	4"	5"	6"
THWN	14	9	17	28	51	70	118	170	265	358	464	736	1055
	12	6	12	20	37	51	86	124	193	261	338	537	770
	10	4	7	13	23	32	54	78	122	164	213	338	485
	8	2	4	7	13	18	31	45	70	95	123	195	279
THHN FEP (14 through 8)	6	1	3	5	9	13	22	32	51	68	89	141	202
	4	1	1	3	6	8	14	20	31	42	54	86	124
	3	1	1	3	5	7	12	17	26	35	46	73	105
	2	1	1	2	4	6	10	14	22	30	39	61	88
	1	0	1	1	3	4	7	10	16	22	29	45	65
PFA (14 through 4/0)	1/0	0	1	1	3	4	7	10	15	20	27	42	61
	2/0	0	1	1	2	3	5	8	12	17	22	35	50
	3/0	0	1	1	1	2	4	6	10	14	18	29	41
	4/0	0	0	1	1	1	4	5	8	11	15	24	34
Z (14 through 4/0)	250	0	0	1	1	1	3	4	6	9	11	18	26
	300	0	0	1	1	1	2	3	5	7	10	15	22
	350	0	0	0	1	1	1	3	5	6	8	14	20
	400	0	0	0	1	1	1	3	4	6	7	12	17
XHHW (4 through 55 kcmil)	500	0	0	0	1	1	1	2	3	5	6	10	14
	600	0	0	0	0	1	1	1	3	4	5	8	11
	700	0	0	0	0	1	1	1	2	3	4	7	10
	750	0	0	0	0	1	1	1	2	3	4	6	9
XHHW	6	1	2	4	8	11	19	28	43	59	76	121	173
	600	0	0	0	0	1	1	1	3	4	5	8	11
	700	0	0	0	0	1	1	1	2	3	4	7	10
	750	0	0	0	0	1	1	1	2	3	4	6	9

Conduit & Utility Duct Packaging Data

Schedule 40 and Schedule 80 Conduit

Size Inches	Feet per Bundle	10' Lengths			20' Lengths		
		Feet per Pack	Approx. Weight per Pack		Feet per Pack	Approx Weight per Pack	
			Sch. 40	Sch. 80		Sch. 40	Sch. 80
1/2	100	6,000	1044	1314	12,000	2088	--
3/4	100	4,400	1016	1309	8,000	2032	--
1	100	3,600	1234	1579	7,200	2468	3155
1-1/4	50	3,300	1521	2007	6,600	2042	4010
1-1/2	50	2,250	1242	1660	4,500	2484	2855
2	--	1,400	1039	1426	2,800	2078	2892
2-1/2	--	930	1094	1448	1,860	2188	2892
3	--	880	1448	1977	1,760	2896	3667
3-1/2	--	630	1248	1605	1,260	2496	--
4	--	570	1337	1854	1,140	2674	3474
5	--	380	1208	1715	760	2416	3216
6	--	260	1075	1616	520	2150	3025
8	--	180	1076	--	360	2152	--

EB & DB Utility Duct - 20' Lengths

Size Inches	Feet per Bundle	Feet per Pack	Approx. Weight per Pack			
			DB60	EB20	DB120	EB35
1	100	7,200	--	--	1176	--
1-1/2	100	4,500	--	--	1142	--
2	--	2,800	944	907	1079	--
3	--	1,760	1464	862	1529	--
4	--	1,140	1567	1056	1907	1171
5	--	760	1579	1064	1919	1281
6	--	520	1560	1026	1833	1195

Telephone Conduit - 20' Lengths

Spec	Size (Inch)	Feet per Pack	Approx Weight per Pack		
			Type B	Type C	Type D
CAO	4	1,260	1272	2030	1885
Commercial	4	1,260	--	1703	--

Truck Load Chart

Product	Size Inches	Pieces per Pack	Feet per Pack	Pack Value
Sch. 40 & Sch. 80 conduit 10' lengths (For 20' lengths, double the 10' pack value shown)	1/2	600	3,000	8
	3/4	440	4,400	10
	1	360	3,600	13
	1-1/4	330	3,300	16
	1-1/2	225	2,250	16
	2	140	1,400	13
	2-1/2	93	930	13
	3	88	880	20
	3-1/2	63	630	20
	4	57	570	20
	5	38	380	20
	6	26	260	20
EB & DB Utility Duct 20' lengths	8	18	180	27
	1	360	7,200	26
	1-1/2	225	4,500	32
	2	140	2,800	26
	3	88	1,760	40
	4	57	1,140	40
	5	38	760	40
EZ Flex® ENT 10' Lengths	6	26	520	40
	1/2	360	3,600	10
	3/4	400	4,000	10
Telephone Conduit - CAO 20' lengths	1	240	2,400	10
	4	63	1,260	53
Telephone Conduit - Commercial 20' lengths	4	63	1,260	53

Limited Warranty

The Seller, **CANTEX INC.**, warrants its PVC plastic pipe, conduit, fittings, accessories, residential electrical boxes and solvents against defective workmanship and material for a period of one year from date of applicable invoice. Seller's liability hereunder, either for breach of warranty or for negligence, is expressly limited, at Seller's option, to:

A) Replacement at the agreed point of delivery, at no cost to the Purchaser, of any product found by the Seller to be defective or found not to conform to the applicable industry manufacturing standards, or

B) to refund or credit to the Purchaser of the purchase price of such products, provided the Seller is notified immediately upon the discovery of any claimed defect and that representative samples of the allegedly defective product are returned, transportation prepaid, to Seller, F.O.B. shipping point, at Seller's request. No claim under this Limited Warranty will be considered until the product and representative samplings thereof have been examined by Seller.

The above warranty constitutes the entire liability of Seller. Seller shall not be liable for any incidental consequential damages directly or indirectly arising or resulting from the sale, transportation, handling, installation or use of the products sold, nor for product loss, re-installation or labor cost.

**THIS WARRANTY IS EXPRESSLY IN LIEU OF ANY OTHER WARRANTIES,
EXPRESSED OR IMPLIED, INCLUDING ANY IMPLIED WARRANTY OF
MERCHANTABILITY OR FITNESS FOR ANY PARTICULAR PURPOSE, AND
OF ANY OTHER OBLIGATION OR LIABILITY ON THE PART OF THE SELLER.**

Situations that void this Limited Warranty:

- 1. Excessive temperature combination during test of operation.**
- 2. Use of the product under conditions for which the product was not designed**
- 3. Failure to adhere to Seller's General Instruction Sheets concerning the proper handling, installation and testing of the product. General Instruction sheets are available on request: Call 817-215-7000.**
- 4. Use of non-suitable solvent cement. Suitable solvent cement shall be cement made in accordance with ASTM D 2564 and of the proper grade (viscosity) for the size of pipe being joined. CANTEX solvent cements meet these requirements.**

CANTEX

817-215-7000 · 301 Commerce Ste. 2700
Fort Worth, Texas 76102

940-325-3344 · 2101 NE 1st Street
Mineral Wells, Texas 76067

330-995-3665 · 11444 Chamberlain Rd. #1
Aurora, Ohio 44202

330-995-3665m · 101 Gandy Road
Auburndale, Florida 33823

928-681-3301 · 4045 Bonanza Drive
Kingman, Arizona 86401

Authorized Distributor Policy

1. BUYER'S ACCEPTANCE

No waiver, alteration or modification of these conditions will be binding unless in writing signed by an authorized employee of **CANTEX INC.**

2. PAYMENT TERMS

All prices are F.O.B. shipping point with freight costs being collect, prepaid or allowed and do not include local, state or Federal taxes. Taxes are for the account of Buyer. Payment terms appear on the face of Buyers invoice. All orders are subject to credit approval.

3. DELINQUENCY FEES

If any invoice or part thereof is not paid within 30 days of date of invoice, **CANTEX** will impose as Delinquency Fees a charge of one (1%) percent per month or the maximum applicable legal amount upon any overdue amount to offset **CANTEX's** anticipated damages including collection and accounting costs. Buyer agrees that the law of the State of Buyer's location will govern the construction and validity of this Contract and all other legal aspects of this sale.

4. CANCELLATION

Buyer may cancel prior to shipment subject to Delinquency Fees of the cost of labor, overhead and materials used plus ten (10%) percent of the sales price. Special orders may not be canceled.

5. RETURNS

No material may be returned for credit without the Seller's written consent.

6. SHIPMENT / DELIVERY

CANTEX will ship common carrier. Errors for breakage of product delivered by common carrier are Buyer's responsibility. Buyer is responsible for prompt unloading of trucks and/or freight cars. If delivery of products is delayed by Buyer more than 60 days, Buyer will pay **CANTEX** eighty (80%) percent of total cost of products.

7. INSTALLATION

Supervision of installation not included unless specifically requested. **CANTEX** will not be responsible for any delay in performance due to acts of God, war, riots, embargoes, acts of civil or military authorities, fires, floods, accidents, quarantine restrictions, supplier conditions, strikes, differences with workmen, cessation of plant operations, delays in transportation, nuclear incident, shortage of cars, fuel, labor or materials, or any cause beyond the reasonable control of **CANTEX**.

9. COMPLIANCE

CANTEX states its intentions to comply with all Federal laws applicable to **CANTEX's** performance.

**Terms and Conditions of Sale are available for download.
Click the link on our homepage.**

www.cantexinc.com

Authorized Distributor Policy

Returned Good Policy

1. Stock Inventory:
 - A) Permission for such return of good must first be obtained from **CANTEX** in writing. Such request must show **CANTEX** invoice number, date, quantity of items and **CANTEX** part number.
 - B) Material to be returned must be new, unused, properly packaged and in resalable condition. No credit will be issued for open or partially used packages.
 - C) Request for return must be processed within 6 months from the date of purchase.
 - D) The RGA (Returned Goods Authorization) will expire 30 days from date of issue. If the material is received after that date, terms of the return must be renegotiated.
 - E) Material must be received at the location indicated on the RGA or it will become null and void.
 - F) Restocking charge is 25%.
 - G) The distributor will prepay freight cost to return the product and the outbound freight will be deducted from the credit issued.

Our Philosophy

It is the intent of **CANTEX** Inc. to sell our PVC electrical conduit, accessory products and switch and outlet boxes primarily through distributors. We believe the distributors play a necessary and vital role in our company and that it is to our mutual advantage that **CANTEX** offers to its authorized distributors the most complete program possible.

CANTEX's objective is to select and establish recognized electrical distributors to thoroughly cover each geographical area and each market segment that **CANTEX** serves.

Our goal is to be a significant and increasing profit contributor to each of our authorized CANTEX distributors.

In General

With the philosophy stated, **CANTEX** carries out the following steps to insure the competitiveness and full profitability of each of our authorized distributors.

1. **CANTEX** is constantly adding to its line of electrical conduit and accessories.
2. Our products are manufactured to the highest quality standards and meet or exceed all applicable standards.
3. **CANTEX** offers the following benefits to its distributors:
 - A. The best delivery in the industry.
 - B. Referred business.
 - C. Assortment privileges in total product line for quantity discount.
 - D. Fair pricing.
 - E. We will drop-ship prepaid orders at no extra charge.
4. **CANTEX** aids the sales efforts of our authorized distributors in the following manner:
 - A. Sales leads derived from national advertising and trade shows.
 - B. Conducting sales meetings for our distributors.
 - C. Have an in-place factory direct sales/service staff to assist you in your sales effort.
 - D. Literature and samples for promotional purposes.
5. We expect an authorized **CANTEX** distributor to:
 - A. Maintain products in inventory.
 - B. Use best efforts and due diligence in the promotion and sale of **CANTEX** products.
 - C. Maintain their account on a current basis.
6. **CANTEX** reserves the right to quote special drop-shipments only through those distributors who maintain an acceptable inventory of **CANTEX** products.



301 Commerce Suite 2700

Fort Worth, Texas 76102

Ph: (817) 215-7000

Fax: (817) 215-7001