

## For Residential and Commercial Applications

Job Name		Engineer / Architect	
Job Location		Wholesaler	
Submittal Date		Contractor	

# OR10/12/32/STR10/12/SSR10 Multi-Turn Straight Stop – Female Iron Pipe x Compression

**Use:** For use in potable water distribution systems in accessible locations only. Not intended for recirculation systems/continuous use of temperatures above 115° F. For those applications, use our KT™ series ball stop.

**Design Features:**

- **Machined one-piece brass body** provides strength, durability, and long-lasting performance
- **Oval knurled handle** provides a secure grip and smooth on/off operation
- **Easy-to-remove handle** with screw attachment helps protect against accidental operation during rough-ins



**Operating Specifications:**

**Temperature:** 40° - 160° F  
**Pressure:** 125 PSI maximum



Excludes loose key handle

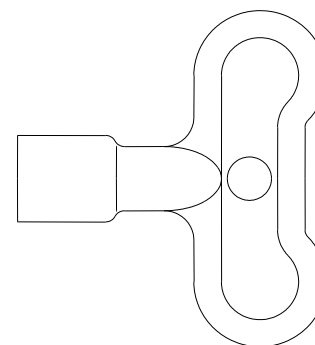
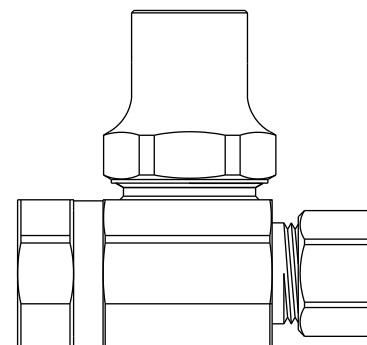
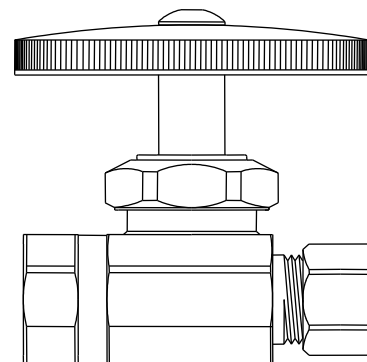

### STOP MATERIAL SPECIFICATIONS

<b>Body</b>	<i>Brass or brass, chrome plated</i>
<b>Stem</b>	<i>POM or brass</i>
<b>Bib &amp; Packing Washers</b>	<i>Rubber</i>
<b>Packing Nut</b>	<i>Brass or brass, chrome plated</i>
<b>Handle</b>	<i>Zinc, die cast plated; ABS, plated; or polycarbonate</i>
<b>Handle Screw</b>	<i>Steel, zinc plated</i>
<b>Compression Sleeve</b>	<i>Brass</i>
<b>Compression Nut</b>	<i>Brass or brass, chrome plated</i>

**Part Listing:**

- |                          |          |   |
|--------------------------|----------|---|
| <input type="checkbox"/> | OR10X C  | 3/8" FIP x 3/8" OD compression, chrome plated             |
| <input type="checkbox"/> | OR10X C1 | 3/8" FIP x 3/8" OD compression, chrome plated, window box |
| <input type="checkbox"/> | OR10X R  | 3/8" FIP x 3/8" OD compression, rough brass               |
| <input type="checkbox"/> | OR10X BZ | 3/8" FIP x 3/8" OD compression, oil-rubbed bronze         |
| <input type="checkbox"/> | OR102X C | 3/8" FIP x 3/8" OD compression, brass stem, chrome plated |
| <input type="checkbox"/> | OR12X C  | 1/2" FIP x 3/8" OD compression, chrome plated             |
| <input type="checkbox"/> | OR12X C1 | 1/2" FIP x 3/8" OD compression, chrome plated, window box |
| <input type="checkbox"/> | OR12X R  | 1/2" FIP x 3/8" OD compression, rough brass               |
| <input type="checkbox"/> | OR122X C | 1/2" FIP x 3/8" OD compression, brass stem, chrome plated |
| <input type="checkbox"/> | OR32X C  | 1/2" FIP x 1/2" OD compression, chrome plated             |
| <input type="checkbox"/> | OR32X C1 | 1/2" FIP x 1/2" OD compression, chrome plated, window box |
| <input type="checkbox"/> | OR32X CD | 1/2" FIP x 1/2" OD compression, chrome plated, carded     |

*This specification and all information contained herein is the confidential and exclusive property of BrassCraft Manufacturing Company and shall not be disclosed to others without the written consent of BrassCraft. This specification must be returned to BrassCraft if requested.*

**OR10/12/32/STR10/12/SSR10 Multi-Turn Straight Stop –  
Female Iron Pipe x Compression**

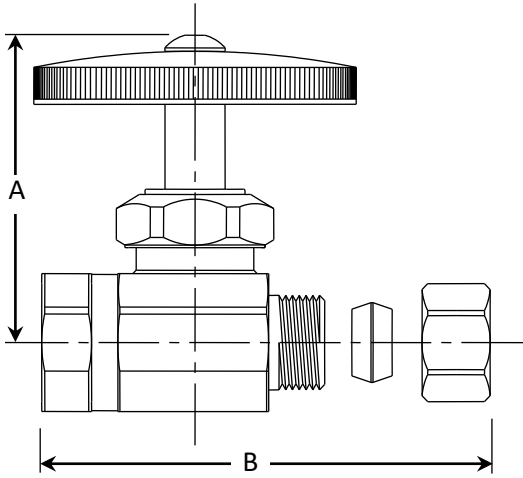

<b>PART DIMENSIONS (Inches)</b>		
<b>Model</b>	<b>DIM. A</b>	<b>DIM. B</b>
OR10X	1.94	2.02
OR10ZX	1.94	2.02
OR12X	1.63	2.07
OR12ZX	1.63	2.07
OR32X	1.70	2.22

**Listings & Certifications:**

- IAPMO listed to ASME A112.18.1 / CSA B125.1 (includes NSF/ANSI 372 & NSF61)

NSF/ANSI/  
CAN61:Q≤0.5



*This specification and all information contained herein is the confidential and exclusive property of BrassCraft Manufacturing Company and shall not be disclosed to others without the written consent of BrassCraft. This specification must be returned to BrassCraft if requested.*

400.30 OR10/12/32 Multi-Turn Straight Stop-FIP x Comp REV 3.23

**BrassCraft®**

©2023 BrassCraft Manufacturing Company