

# Installation

WF2605

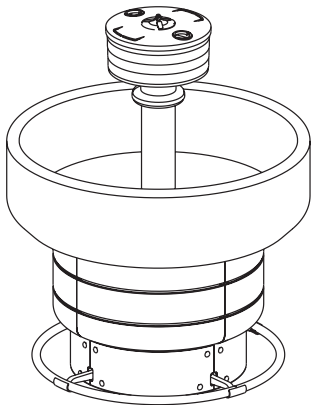

WF3203

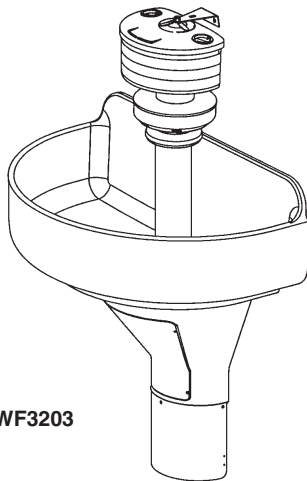

**WF2500 Series Terreon Classic**  
**WF2600 Series Terrazzo**  
**WF2700 Series Stainless Steel**  
**WF2800 Series Bradstone**  
**WF3200 Series Terreon Deep Bowl**  
**TDB3100 Series Terreon Deep Bowl**

## WARNING

Make sure that all water supply lines have been flushed and then completely turned off before beginning installation. Debris in the supply lines can cause valves to malfunction.

Turn OFF electrical supply to the unit before installation.

## NOTICE

Main water supply to the unit should be "ON" at all times.

## IMPORTANT

Read this installation manual completely to ensure proper installation, then file it with the owner or maintenance department. Compliance and conformity to drain requirements and other local codes and ordinances is the responsibility of the installer.

Separate parts from packaging and make sure all parts are accounted for before discarding any packaging material. If any parts are missing, do not begin installation until you obtain the missing parts.

Product warranties and parts information may also be found under "Products" on our web site at [bradleycorp.com](http://bradleycorp.com).





## Cleaning and Maintenance for Terreon®

**Material Description:** Terreon is a densified solid surface material composed of bio based resin and is resistant to chemicals, stains, burns and impact. Surface can be easily repaired with everyday cleansers or fine grit abrasives. Because Terreon is a unique cast material, its aggregate flow and distribution, and shades of color can vary from product to product creating natural characteristics.

**Routine Cleaning:** For regular cleaning, use mild neutral base cleaners.

**Stubborn Stains:** Remove tough stains with Soft-Scrub® and a green Scotch-Brite® pad or lightly sand in a circular motion with 240 grit wet/dry sandpaper. The finish can then be renewed with a maroon Scotch-Brite pad.

**Scratches:** Remove scratches with a green Scotch-Brite pad. The finish can then be renewed with a maroon Scotch-Brite pad.

**Hard Water Deposits:** Remove hard water deposits with a mild solution of vinegar and water. Always rinse the unit thoroughly after cleaning.

**Restoring the surface:** Use Hope's® Perfect Countertop to refresh and protect the Terreon Solid Surface material. Dark Terreon colors may require additional care and maintenance. For complete instructions on this additional maintenance, visit bradleycorp.com.

**Repair Kits:** Terreon repair kits are available. Contact your Bradley representative or distributor for part numbers and pricing. Repair kits are made to order and have a shelf life of 30 days.

**NOTICE!** Do not use strong acid or alkaline chemicals and cleaners to clean Terreon. If these chemicals come in contact with the surface, wipe them off immediately and rinse with soapy water. Avoid contact with harsh chemicals such as paint remover, bleach, acetone, etc. Avoid contact with hot pans and objects.

## Cleaning and Maintenance for Stainless Steel

**Material Description:** Stainless steel is extremely durable, and maintenance is simple and inexpensive. Proper care, particularly under corrosive conditions, is essential. Always start with the simplest solution and work your way toward the more complicated.

**Routine cleaning:** Daily or as often as needed use a solution of warm water and soap, detergent, or ammonia. Apply the cleaning solution per the manufacturer's instructions and always use a soft cloth or sponge to avoid damaging the finish.

**Stubborn Stains:** To remove stains from stainless steel use a stainless steel cleaner and polish such as Ball® stainless steel cleaner or a soft abrasive. Always follow the manufacturer's instructions and apply in the same direction as the polish lines.

**NOTICE!** Never use ordinary steel wool or steel brushes on stainless steel. Always use stainless steel wool or stainless steel brushes.

**Fingerprints and Smears:** To remove fingerprints or smears use a high quality stainless steel cleaner and polish in accordance with the manufacturer's instructions. Many of these products leave a protective coating that helps prevent future smears and fingerprints.

**Grease and Oil:** To remove grease and oil use a quality commercial detergent or caustic cleaner. Apply in accordance to the manufacturer's instructions and in the direction of the polish lines.

**Precautions:** Avoid prolonged contact with chlorides (bleaches, salts), bromides (sanitizing agents), thiocyanates (pesticides, photography chemicals, and some foods), and iodides on stainless steel equipment, especially if acid conditions exist.

**NOTICE!** Do not permit salty solutions to evaporate and dry on stainless steel.

The appearance of rust streaks on stainless steel leads to the belief that the stainless steel is rusting. Look for the actual source of the rust in some iron or steel particles which may be touching, but not actually a part of the stainless steel structure.

**NOTICE!** Strongly acidic or caustic cleaners may attack the steel causing a reddish film to appear. The use of these cleaners should be avoided.

## Brand Names

Use of brand names is intended only to indicate a type of cleaner. This does not constitute an endorsement, nor does the omission of any brand name cleaner imply inadequacy. Many products named are regional in distribution, and can be found in local supermarkets, department and hardware stores, or through your cleaning service. It is emphasized that all products should be used in strict accordance with package instructions.



## Cleaning and Maintenance for Terrazzo

**Material Description:** Terrazzo is a mosaic-looking natural stone and concrete material polished to a high gloss and sealed with clear polyurethane resin for long lasting beauty. Terrazzo is precast and composed of 85% stone and 15% binder with steel reinforcing rods cast into the bowl.

**Routine Cleaning:** Clean daily or as often as conditions require with any standard detergent, warm water and a soft cloth.

**Stubborn Stains:** If stains have permeated the surface of the terrazzo, follow instructions for restoring the surface listed below.

**Restoring the surface:** Use paint stripper to remove the existing polyurethane (it is important to remove all of the old polyurethane to ensure a high quality finish). Then use light grit sand paper to remove any stubborn stains that have permeated the surface. Clean and thoroughly dry the bowl. Then apply 2 to 3 coats of polyurethane to the terrazzo in accordance with the manufacturer's instructions. Allow the polyurethane to dry completely per the manufacturer's recommendations before turning on the water.

**NOTICE!** If the bowl is not completely dry before applying the polyurethane, the polyurethane will not adhere to the surface.

**NOTICE!** Make sure the surface is completely covered with polyurethane to prevent water from penetrating the surface and damaging the terrazzo.

**Repair Kits:** Terrazzo repair kits are available. Contact your Bradley representative or distributor for part numbers and pricing.

**NOTICE!** Do not place acid or alkaline solutions (floor stripper or drain cleaners) into the terrazzo bowl or use them to clean the bowl. If these solutions come into contact with the terrazzo, rinse the bowl immediately with water and inspect for damage. If damage has occurred, follow the directions for restoring the surface. If bowl begins to haze, it is usually a sign that the terrazzo has come into contact with an acid or alkaline chemical or has been exposed to UV radiation. To repair this condition, follow the instructions for restoring the surface.

## Cleaning and Maintenance for Bradstone

**Material Description:** Bradstone is an extremely durable plastic material made of reinforced thermosetting polyester resins, finely ground inorganic fillers and fade resistant pigments. Bradstone is impervious to most chemicals and stains.

**Routine Cleaning:** Soap and dirt accumulations should be washed off with detergent cleaners. Abrasive and caustic cleaners are not recommended. An occasional waxing with automotive wax will make future cleaning even easier.



# Semi-Circular Bowl and Pedestal Assembly (Terreon® and Bradstone®) WF2503, WF2504, WF2803, WF2804

P.O. Box 309 • Menomonee Falls, WI 53052-0309 • 1 800 BRADLEY • 262 251 6000 • bradleycorp.com



*This document describes installation of washfountain bowl and pedestal only. Terreon Classic and Bradstone washfountains are shipped partially pre-assembled. Some optional equipment and accessories are shown for clarity. For activation, optional equipment and accessory installation, see installation documents included with those parts.*



*Before installation of bowl and pedestal assemblies, review all included instructions. Some options may require additional steps during the bowl and pedestal installation process.*

## Supplies Required by Installer

- (6) 1/2" lag bolts, screws or other fasteners to anchor washfountain pedestal
- 1" hot and cold water or tempered supply lines and fittings (see activation instructions)
- Reducing fittings and 1/2" nom. copper tubing supply lines for types with supplies from above (see activation instructions)
- Standard P-trap (vented trap supplied by Bradley when required)
- 2" drain lines and fittings (see activation instructions)
- 1-1/2" vent pipe on types vented through washfountain column
- Pipe sealant and plumber's putty



*Supply lines for one or two washfountains should be 1"; for three washfountains 1-1/4"; for more than three washfountains, pipe size should increase proportionally. Vent pipe to be 1-1/2" on models vented through washfountain.*



*Valving installations for Classic washfountains require rigid plumbing installation and connections to ensure proper operation and support of the valve assemblies, especially for foot control activated washfountains. Do not use flexible supply hoses unless specified in your activation instruction documentation and supplied with your washfountain.*



# Semi-Circular Bowl and Pedestal Assembly (Terreon® and Bradstone®) WF2503, WF2504, WF2803, WF2804

P.O. Box 309 • Menomonee Falls, WI 53052-0309 • 1 800 BRADLEY • 262 251 6000 • bradleycorp.com

## Semi-Circular Washfountain Dimensions

(mm)

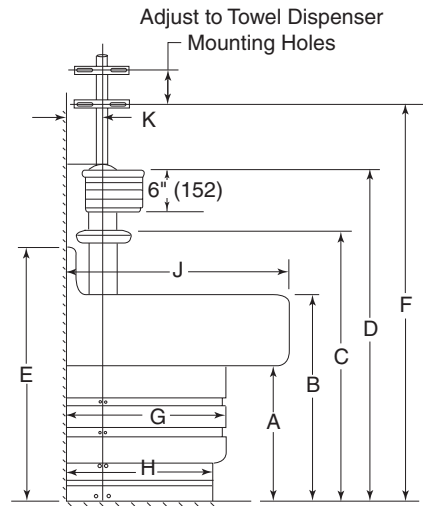

**Approximate Dimensions in Inches\***

Material	Size	A	B	C	D	E	F	G	H	J	K
Terreon	54"	19	29-1/2	38-3/4	47-1/4	36-1/2	55-3/4	23-1/2	21-1/4	32-1/4	5-1/4
Terreon	36"	19	29-1/2	35-1/4	43-1/4	33-3/8	52-1/4	17-1/4	15-1/4	22-3/4	4-3/4
Bradstone	54"	19-3/4	29-1/4	37-1/2	46	35-1/4	54-3/8	26-1/4	24-1/4	35-1/4	8-1/4
Bradstone	36"	19-3/4	29-1/4	34	42-1/2	35-1/4	50-7/8	20-1/4	18-1/4	25-3/4	7-3/4

\* Subtract 4" from dimensions A through E for juvenile height. Bradstone not available in juvenile height.

**Approximate Dimensions in Millimeters\***

Material	Size	A	B	C	D	E	F	G	H	J	K
Terreon	1372mm	483	749	984	1200	927	1416	597	540	819	133
Terreon	914mm	483	749	895	1099	848	1327	438	387	578	121
Bradstone	1372mm	502	743	953	1168	895	1381	667	616	895	210
Bradstone	914mm	502	743	864	1080	895	1292	514	464	654	197

\* Subtract 102mm from dimensions A through E for juvenile height. Bradstone not available in juvenile height.



# Semi-Circular Bowl and Pedestal Assembly (Terreon® and Bradstone®) WF2503, WF2504, WF2803, WF2804

P.O. Box 309 • Menomonee Falls, WI 53052-0309 • 1 800 BRADLEY • 262 251 6000 • bradleycorp.com

## Length of Tie Pipe Required for Vent Through Washfountain Column

Type	Pipe Length
54" Less Soap Dispenser	21-1/2" (543mm)
36" Less Soap Dispenser	18" (457mm)
54" with Soap Dispenser	30" (762mm)
36" with Soap Dispenser	26-1/2" (673)
54" Less Soap Dispenser with Towel Dispenser	55-1/2" (1410mm)
36" Less Soap Dispenser with Towel Dispenser	52" (1321mm)
54" with Soap Dispenser with Towel Dispenser	48" (1213mm)
36" with Soap Dispenser with Towel Dispenser	44-1/2" (1130mm)
54" with Cube Adapter	32" (813mm)
36" with Cube Adapter	28-1/2" (724mm)
54" with Cube Adapter with Towel Dispenser	50" (1270mm)
36" with Cube Adapter with Towel Dispenser	46-1/2" (1181mm)
54" with Cube Adapter and Soap Dispenser	40" (1016mm)
36" with Cube Adapter and Soap Dispenser	36-1/2" (927mm)



*Drain must be connected with 2" schedule 40 welded wrought iron pipe, minimum, to provide lower support for this installation. Vent or support pipe must be of the same material in 1-1/2". For detailed tie pipe information, see 215-1834-26.*



# Semi-Circular Bowl and Pedestal Assembly (Terreon® and Bradstone®) WF2503, WF2504, WF2803, WF2804

P.O. Box 309 • Menomonee Falls, WI 53052-0309 • 1 800 BRADLEY • 262 251 6000 • bradleycorp.com

## Rough-In Specifications

(mm)

### Type A

Off-line vent with  
supplies from below

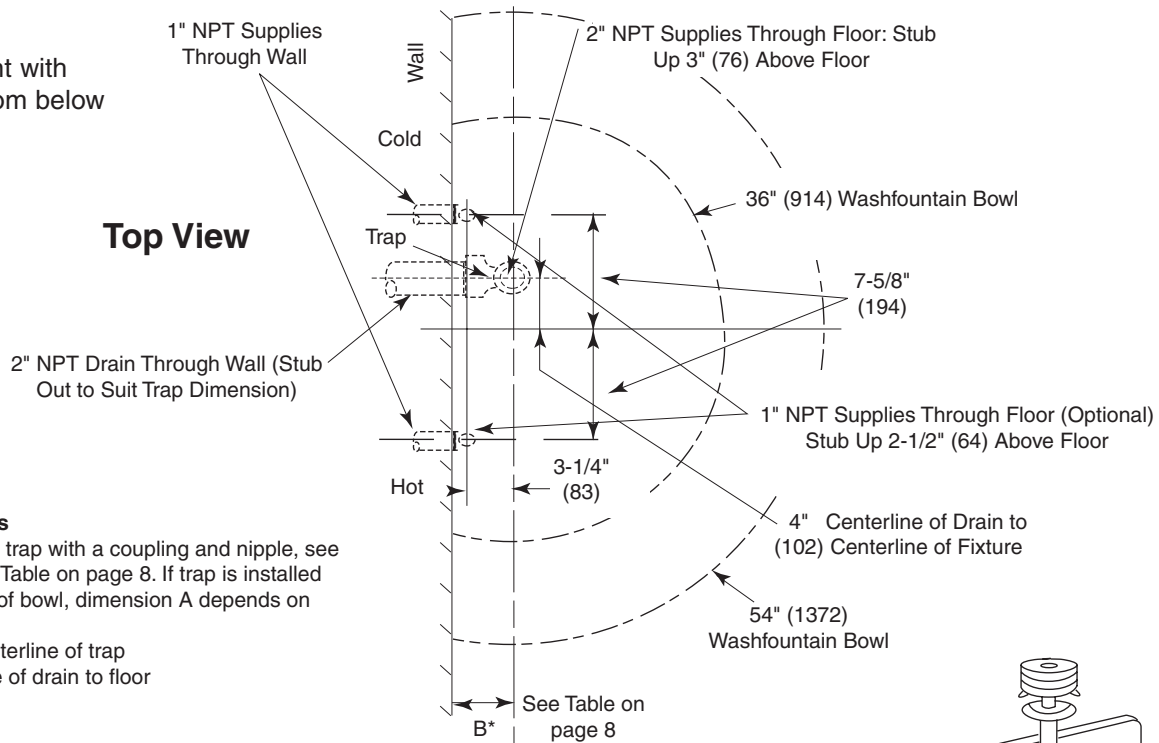

#### Installing Traps

When installing trap with a coupling and nipple, see dimension A in Table on page 8. If trap is installed tight to bottom of bowl, dimension A depends on design of trap.

\*B - Wall to centerline of trap

\*\*A - Centerline of drain to floor

### Side View

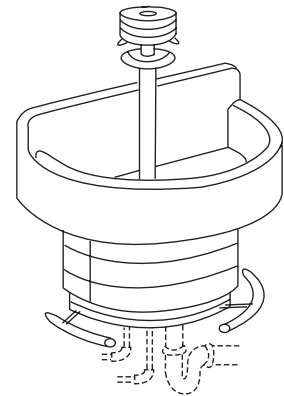
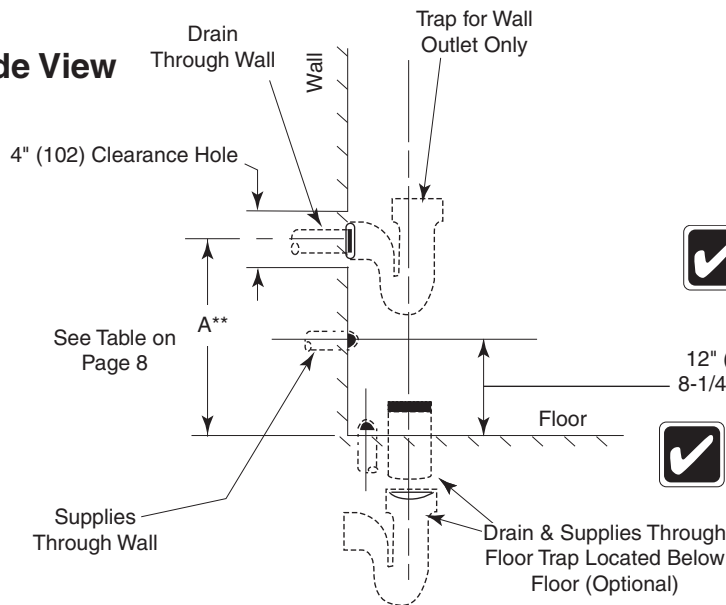

Some optional equipment shown.

12" (305) for Standard Height  
8-1/4" (210) for Juvenile Height



UPC and IPC restrict the vertical distance from the fixture outlet to the trap weir to not more than 24". Check state and local codes for variances.

#### Rough-In Notes

1. All pipes and fittings not furnished by Bradley are shown in broken lines.
2. Supply lines for one to two washfountains should be 1", for three washfountains 1-1/2"; for more than three washfountains, pipe sizes should be increased proportionately.
3. Overhead supplies must be reduced to 1/2" copper tube to pass through support tube.
4. Check valve inlets are 1/2" NPT.



# Semi-Circular Bowl and Pedestal Assembly (Terreon® and Bradstone®) WF2503, WF2504, WF2803, WF2804

P.O. Box 309 • Menomonee Falls, WI 53052-0309 • 1 800 BRADLEY • 262 251 6000 • bradleycorp.com

## Rough-In Specifications

(mm)

### Type O

Off-line vent with  
supplies from above

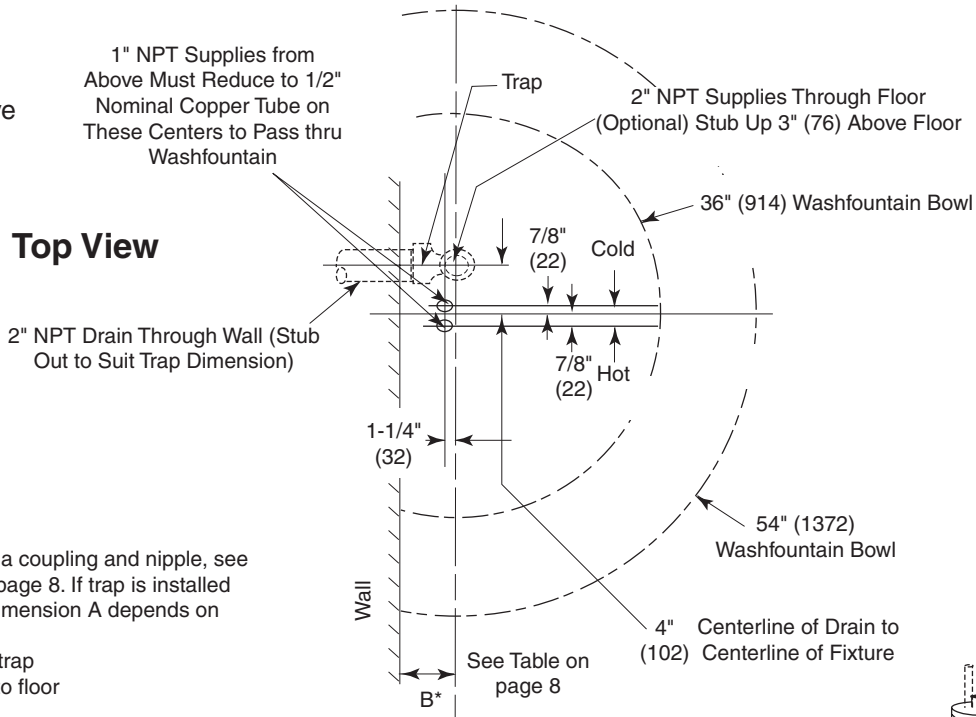

#### Installing Traps

When installing trap with a coupling and nipple, see dimension A in Table on page 8. If trap is installed tight to bottom of bowl, dimension A depends on design of trap.

\*B - Wall to centerline of trap

\*\*A - Centerline of drain to floor

### Side View

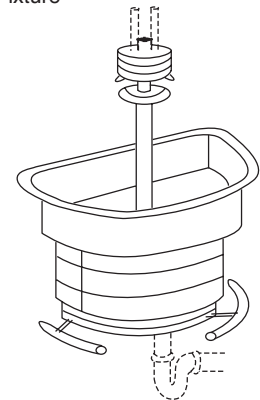
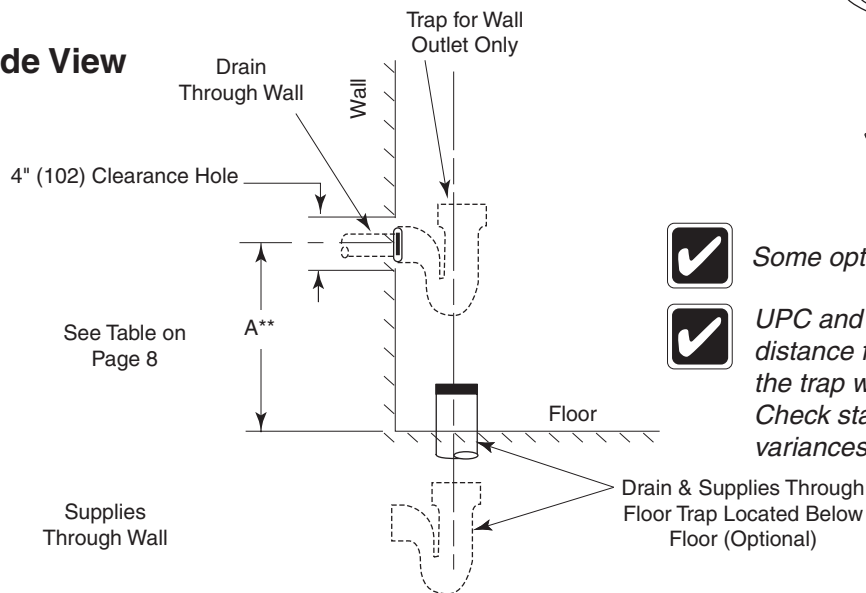

Some optional equipment shown.



UPC and IPC restrict the vertical distance from the fixture outlet to the trap weir to not more than 24". Check state and local codes for variances.

#### Rough-In Notes

1. All pipes and fittings not furnished by Bradley are shown in broken lines.
2. Supply lines for one to two washfountains should be 1", for three washfountains 1-1/2"; for more than three washfountains, pipe sizes should be increased proportionately.
3. Overhead supplies must be reduced to 1/2" copper tube to pass through support tube.
4. Check valve inlets are 1/2" NPT.





# Semi-Circular Bowl and Pedestal Assembly (Terreon® and Bradstone®) WF2503, WF2504, WF2803, WF2804

P.O. Box 309 • Menomonee Falls, WI 53052-0309 • 1 800 BRADLEY • 262 251 6000 • bradleycorp.com

## Rough-In Specifications

(mm)

### Type B

Centrally Rising Vent  
with Supplies from  
Above

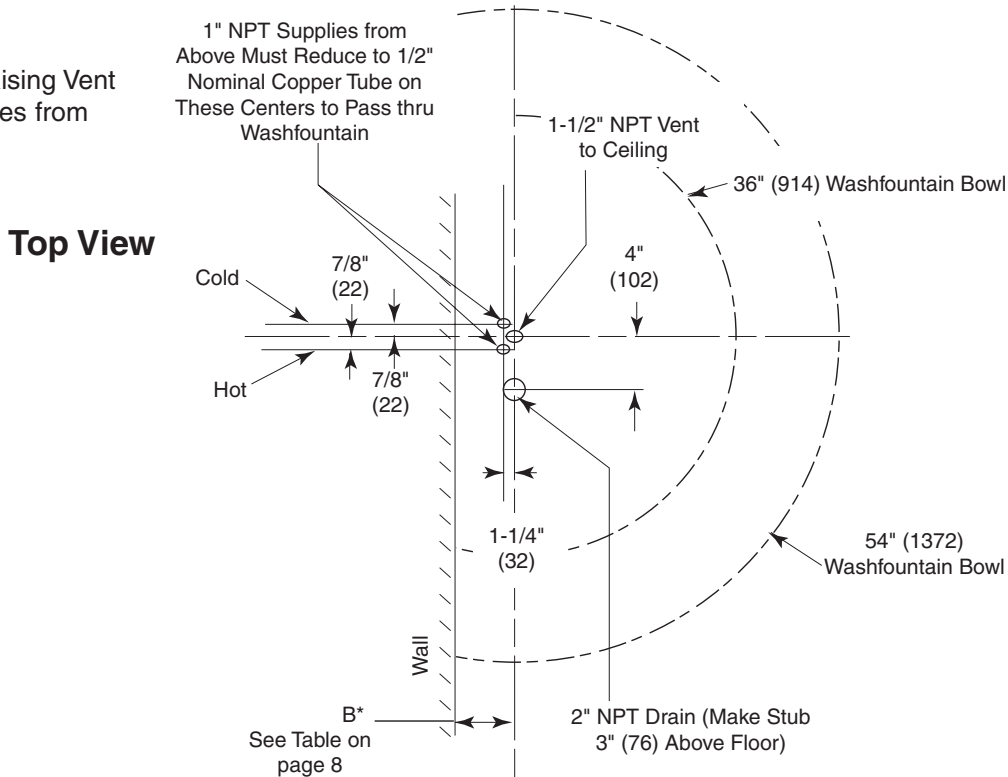

### Side View

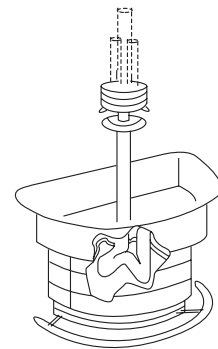
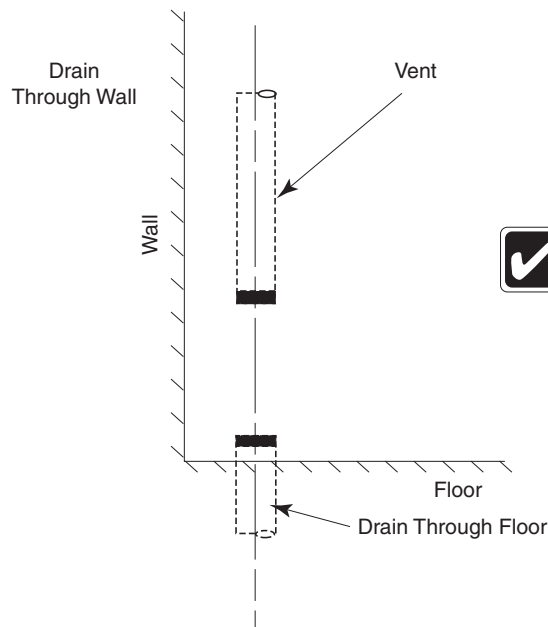

Some optional equipment shown.

### Rough-In Notes

1. All pipes and fittings not furnished by Bradley are shown in broken lines.
2. Supply lines for one to two washfountains should be 1", for three washfountains 1-1/2"; for more than three washfountains, pipe sizes should be increased proportionately.
3. Overhead supplies must be reduced to 1/2" copper tube to pass through support tube.
4. Check valve inlets are 1/2" NPT.
5. For maximum rigidity of sprayhead/support tube assembly, use 1-1/2" NPT galvanized pipe for vent. Use of plastic or copper for vent is not recommended.



# Semi-Circular Bowl and Pedestal Assembly (Terreon® and Bradstone®) WF2503, WF2504, WF2803, WF2804

P.O. Box 309 • Menomonee Falls, WI 53052-0309 • 1 800 BRADLEY • 262 251 6000 • bradleycorp.com

## Rough-In Specifications

(mm)

### Type H

Centrally Rising Vent  
with Supplies from  
Below

#### Top View

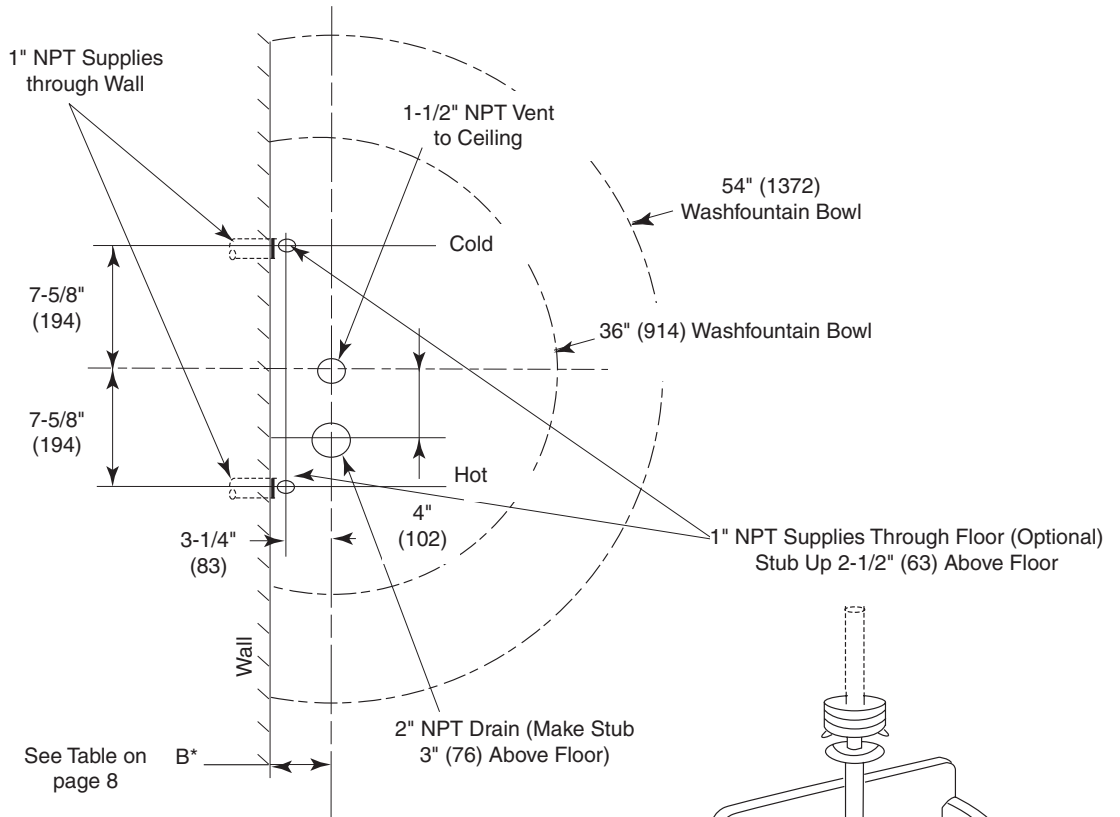

#### Side View

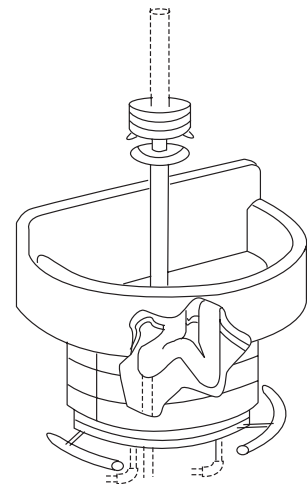
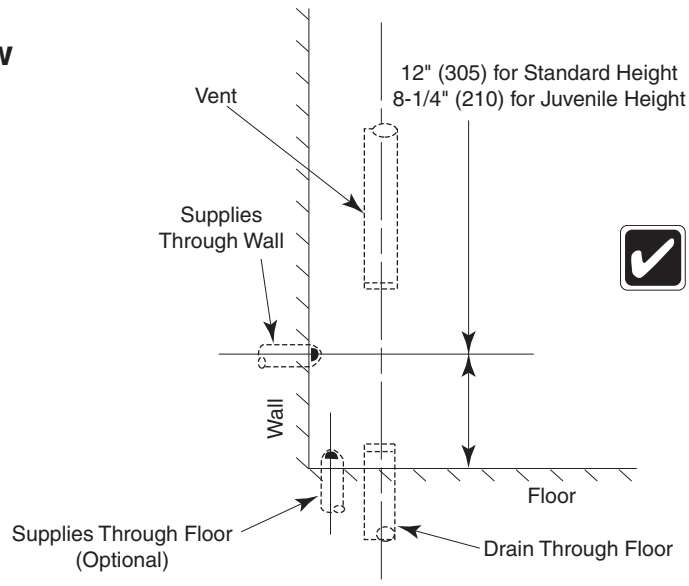

Some optional equipment shown.

#### Rough-In Notes

1. All pipes and fittings not furnished by Bradley are shown in broken lines.
2. Supply lines for one to two washfountains should be 1", for three washfountains 1-1/2"; for more than three washfountains, pipe sizes should be increased proportionately.
3. Overhead supplies must be reduced to 1/2" copper tube to pass through support tube.
4. Check valve inlets are 1/2" NPT.
5. For maximum rigidity of sprayhead/support tube assembly, use 1-1/2" NPT galvanized pipe for vent. Use of plastic or copper for vent is not recommended.



# Semi-Circular Bowl and Pedestal Assembly (Terreon® and Bradstone®) WF2503, WF2504, WF2803, WF2804

P.O. Box 309 • Menomonee Falls, WI 53052-0309 • 1 800 BRADLEY • 262 251 6000 • bradleycorp.com

## 1 Installing the Drain

**A** Rough in supply and drain piping as required for your installation.

**B** Assemble the drain to the dimension shown below for the bowl size you are installing.



All piping shown in dotted lines to be supplied by installer.

Types A, O

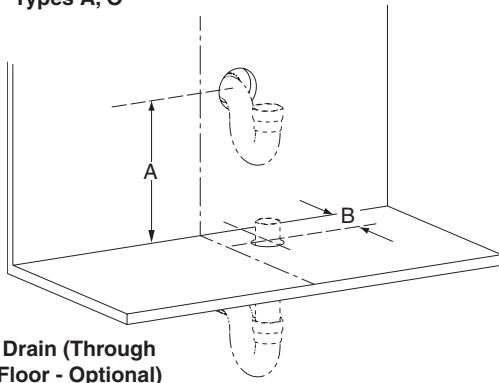

Types B, H

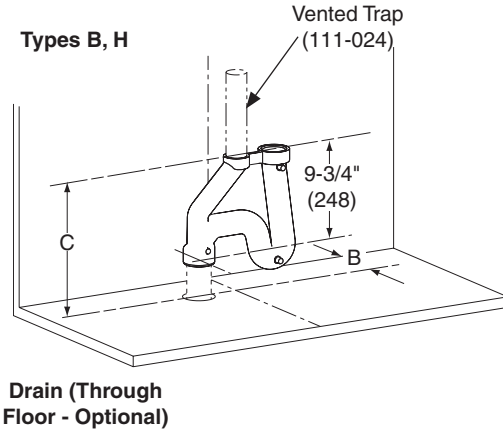

Types A, O

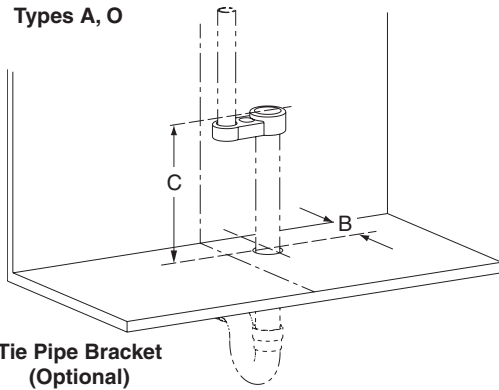

Trap Dimensions (mm)

Bowl Material & Size	A		B	C	
	Standard Height	Juvenile Height		Standard Height	Juvenile Height
54" Terreon	6" (152) to 13-1/4" (336)	6" (152) to 10-1/4" (260)	5-1/4" (133)	18-5/8" (473)	14-5/8" (371)
36" Terreon	6" (152) to 13-1/4" (336)	6" (152) to 10-1/4" (260)	4-3/4" (121)	18-5/8" (473)	14-5/8" (371)
54" Bradstone*	6" (152) to 11-5/8" (295)	N/A	8-1/4" (210)	17" (432)	N/A
36" Bradstone*	6" (152) to 12" (305)	N/A	7-3/4" (197)	17-3/8" (441)	N/A

\* Bradstone is not available in juvenile height.



# Semi-Circular Bowl and Pedestal Assembly (Terreon® and Bradstone®) WF2503, WF2504, WF2803, WF2804

P.O. Box 309 • Menomonee Falls, WI 53052-0309 • 1 800 BRADLEY • 262 251 6000 • bradleycorp.com

## 3 Bowl Assembly and Mounting

**NOTICE!** The pedestal must be level when secured to floor for proper drainage.

**CAUTION!** Use suitable lifting equipment to position bowl and pedestal assembly. Handle with care! Failure to do so could result in serious personal injuries.

**A** Position the bowl and pedestal assembly so that the bowl drain is in line with the trap or drain line.

**B** Drop the spud into the drain to ensure correct alignment.

**C** Level the bowl, if required, by placing washers under the legs. Check fit against the wall and adjust if necessary by loosening the screws attaching the bowl to the pedestal.

**E** Anchor the pedestal to the floor with suitable fasteners (supplied by installer).

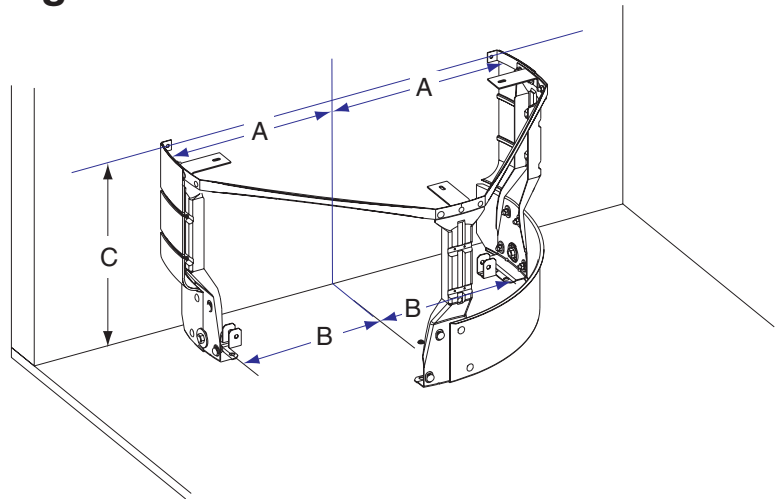

Some optional equipment shown.

**Pedestal Anchoring Dimensions (mm)**

Bowl Material & Size	A	B	C	
			Std. Height	Juv. Height
36" Terreon	11" (279)	8-5/8" (219)	18-1/4" (464)	14-1/4" (362)
54" Terreon	16-1/2" (419)	14-1/8" (359)	18-1/4" (464)	14-1/4" (362)
36" Bradstone*	-	8-5/8" (219)	-	-
54" Bradstone	-	14-1/8" (359)	-	-

## 4 Installing Drain Spud in Bowl

**A** Secure drain spud with lock nut and washers as shown.

**✓** Seal between drain spud and drain hole with plumber's putty (supplied by installer).

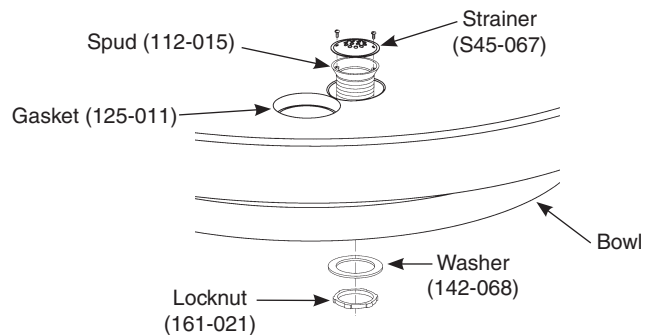



# Sprayheads WF2500, WF2600, WF2700, WF2800, WF3200, TDB3100 Series

P.O. Box 309 • Menomonee Falls, WI 53052-0309 • 1 800 BRADLEY • 262 251 6000 • bradleycorp.com

## Sectional Sprayhead

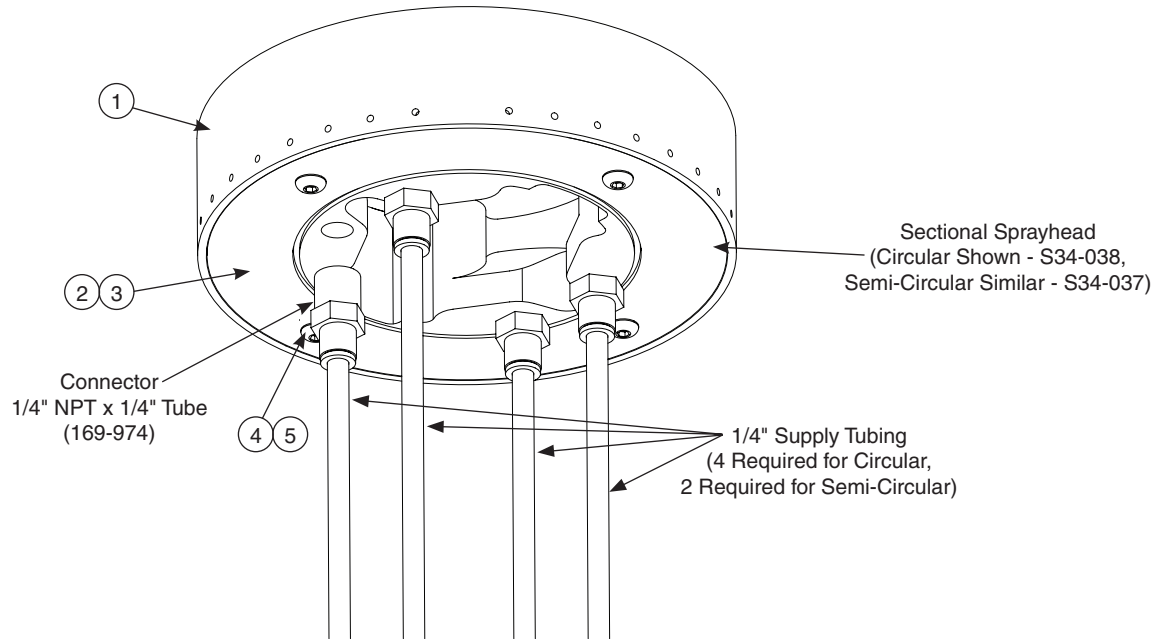

## Parts List

Item	Part No.	Description	Circular	Semi-Circular
			Qty	
1	115-080	Sectional Sprayhead - Plated (Circular)	1	
1	115-079	Sectional Sprayhead - Plated (Semi-Circular)		1
2	159-115	Bottom Plate	1	1
3	124-032	Gasket	1	1
4	160-138	Screw, 10-24 x 1/2" Button Head	4	4
5	142-002BT	Washer, #10, Split Lock	4	4



## Non-Sectional Sprayhead



*Repair kit does not include sprayhead grommet. Order as a separate item.*

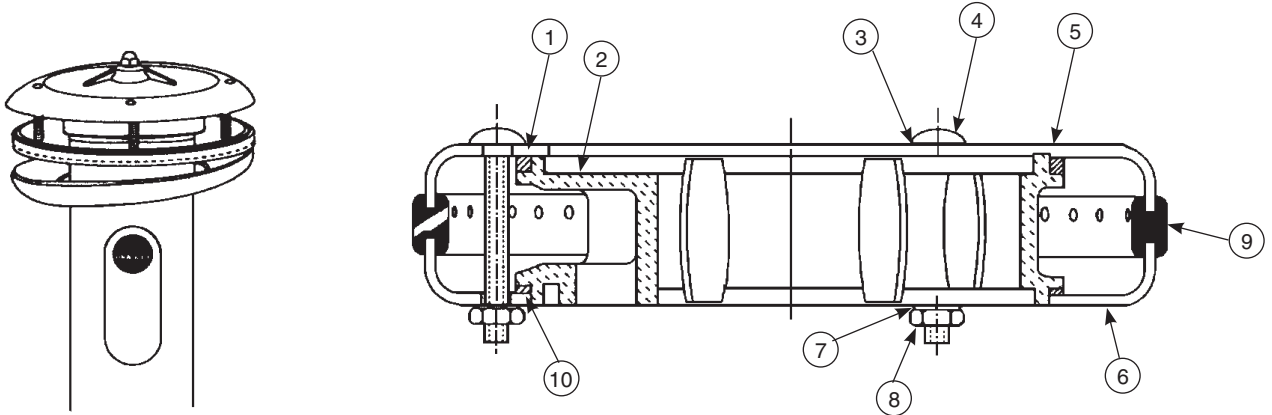

### Parts List

Item	Part No.	Description	Sprayhead Assembly	Repair Kit S45-051
			Qty	
1	125-001DE	Neoprene Washer - Top	1	1
2	139-031	Sprayhead Manifold	1	-
3	124-001AL	Washer	3	4
4	160-211	Carriage Bolt	3	4
5	115-061	Sprayhead Top	1	-
6	116-008	Sprayhead Bottom	1	-
7	124-001AT	Washer	3	4
8	161-025	Nut	3	4
9	124-020C	Sprayhead Grommet - Circle	1	-
9	120-020D	Sprayhead Grommet - Semi-Circle	1	-
9	120-020E	Sprayhead Grommet - Corner	1	-
10	125-001DF	Neoprene Washer - Bottom	1	1



## Sprayhead Troubleshooting

Problem	Cause	Solution
Water splashes over the rim of the bowl.	Foreign matter has reduced the size of the sprayhead slots, causing greater pressure at the open slots.	Clean the sprayhead: <ol style="list-style-type: none"> <li>1. Disassemble the sprayhead and dislodge any dirt, lime build-up and foreign debris with a wire brush.</li> <li>2. Sprayheads with rubber grommet spray rings may be cleaned by rubbing a coin over the grommet.</li> </ol>
		Throttle down the volume control (water spray should strike the bowl without splashing outside of the bowl).
Water flow diminishes from the sprayhead.	Strainer portion of the stop-strainer-check valve is plugged.	Remove and clean the strainer screen from the stop-strainer-check valve.  <i>The non-sectional sprayhead includes a perforated neoprene spray ring grommet that is self-cleaning. The water pressure flexes the spray holes which slows accumulation of foreign matter and tends to "break loose" any such deposits that may have accumulated.</i>

## Sprayhead Tubing Connections

**⚠ WARNING** Flush supply lines before making connections.

**A** Using a sharp razor, cut tubing squarely and remove any burrs. DO NOT pinch or crush end of tubing.

**B** Loosen nut on fitting. Moisten end of tube and push into fitting until it is firmly seated. Tighten nut to secure tube to fitting (make sure nut is securely tightened).

**C** If connector leaks, reseal tubing according to above procedure. If leaking persists, replace male connector, or call a Bradley representative for assistance.

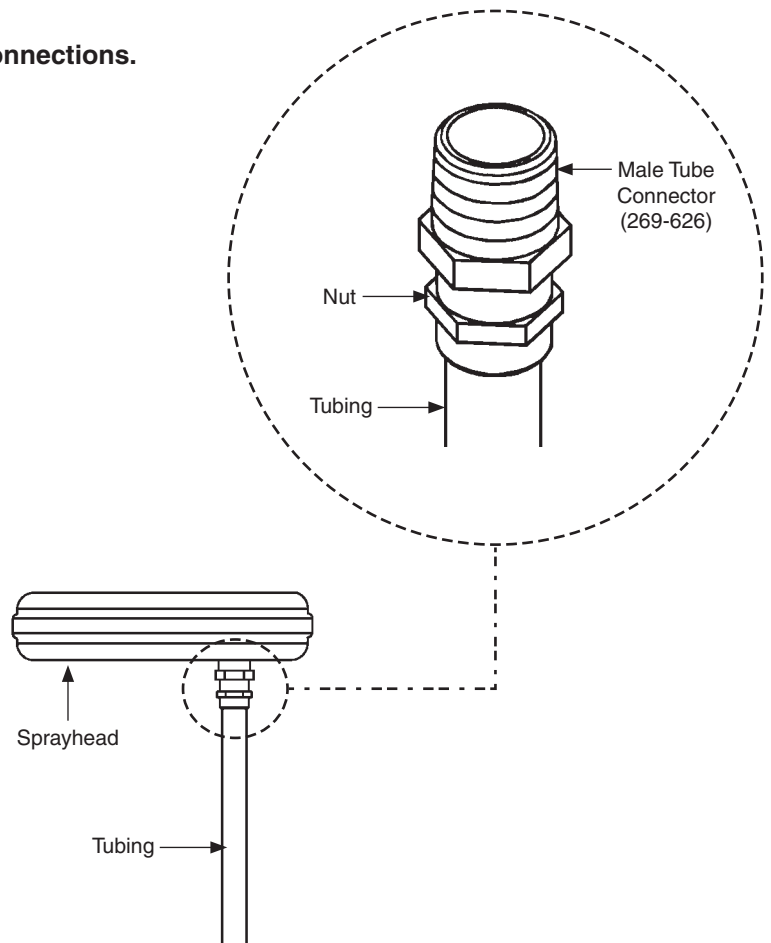



## Supplies Required by Installer

- Pipe sealant and plumbers putty
- 1-1/2" vent pipe on types vented through washfountain column



*Supply lines for one or two washfountains should be 1"; for three washfountains 1-1/4"; for more than three washfountains, pipe size should increase proportionally. Vent pipe to be 1-1/2" on models vented through washfountain.*

## Pre-Installation Information

### Cylindrical Air Valve

The air valve pushbutton allows each user to activate an air metering valve (starting the flow of water) by pushing and releasing the pushbutton. The air metering valve is factory-preset to run for 10 seconds and can be adjusted to run from 5-60 seconds.



*Not all equipment shown in this document is available on all washfountains shown within these pages. See Tech Data for optional equipment available for your washfountain.*





## 1a Air Metering Valve Assembly – A and O Units

**A** Install hemmed end (not sharp end) of support tube with gasket onto bowl. Connect 1/2" dia. tubing to sprayhead.

- Using a sharp razor, cut tubing squarely and remove any burrs. DO NOT pinch or crush end of tubing.
- Loosen nut on fitting. Moisten end of tube and push into fitting until it is firmly seated. Tighten nut to secure tube to fitting (make sure nut is securely tightened).
- If connector leaks, reseal tubing according to above procedure. If leaking persists, replace male connector, or call your Bradley representative for assistance.

**B** Place sprayhead with 1/2" tubing onto support tube. Run the tubing down through the support tube and connect to valve tube connector.

**C** Assemble the lower tie rod (the longer threaded rod), upper tie bar (notched at corners), lower tie bar, tie rod nut and coupling nut, then attach the 4-1/4" tie rod to coupling nut.

Place the air metering module assembly on top of sprayhead. Rotate until module locks in with tie bar. Run 1/8" diameter tubing through the support tube down into the pedestal. and connect to the air valves, taking care that each sprayhead section's 1/2" supply tube and 1/8" activation button tube are connected to the same valve (see detail in Step 2).

**D**



*Skip to step F for units without soap.*

**E**

For units with soap option, install the spacer, soap dispenser and cover using coupling nut, soap tie rod (8-5/8" long) and second coupling nut as shown.

**F**

Secure module cover and dispenser cover with acorn nut and set screw.

**G**

Connect supply stops onto stub-outs.  
Connect flexible hoses to supply stops.

**H**

**FOR O UNIT:** Install 1/2" nominal copper tubing supply lines (pass them through holes in cover down through support column) and connect to stops using suitable fittings.



# Air Metering Activation Modules - Non-Sectional Semi-Circular Washfountains WF2603, WF2604, WF2703, WF2704

P.O. Box 309 • Menomonee Falls, WI 53052-0309 • 1 800 BRADLEY • 262 251 6000 • bradleycorp.com

## 1a Air Metering Valve Assembly – A and O Units



*Some optional equipment shown.*

**Type "O" Drain  
Supplies from Above**

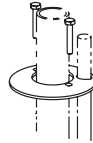

**Type "A" Drain**

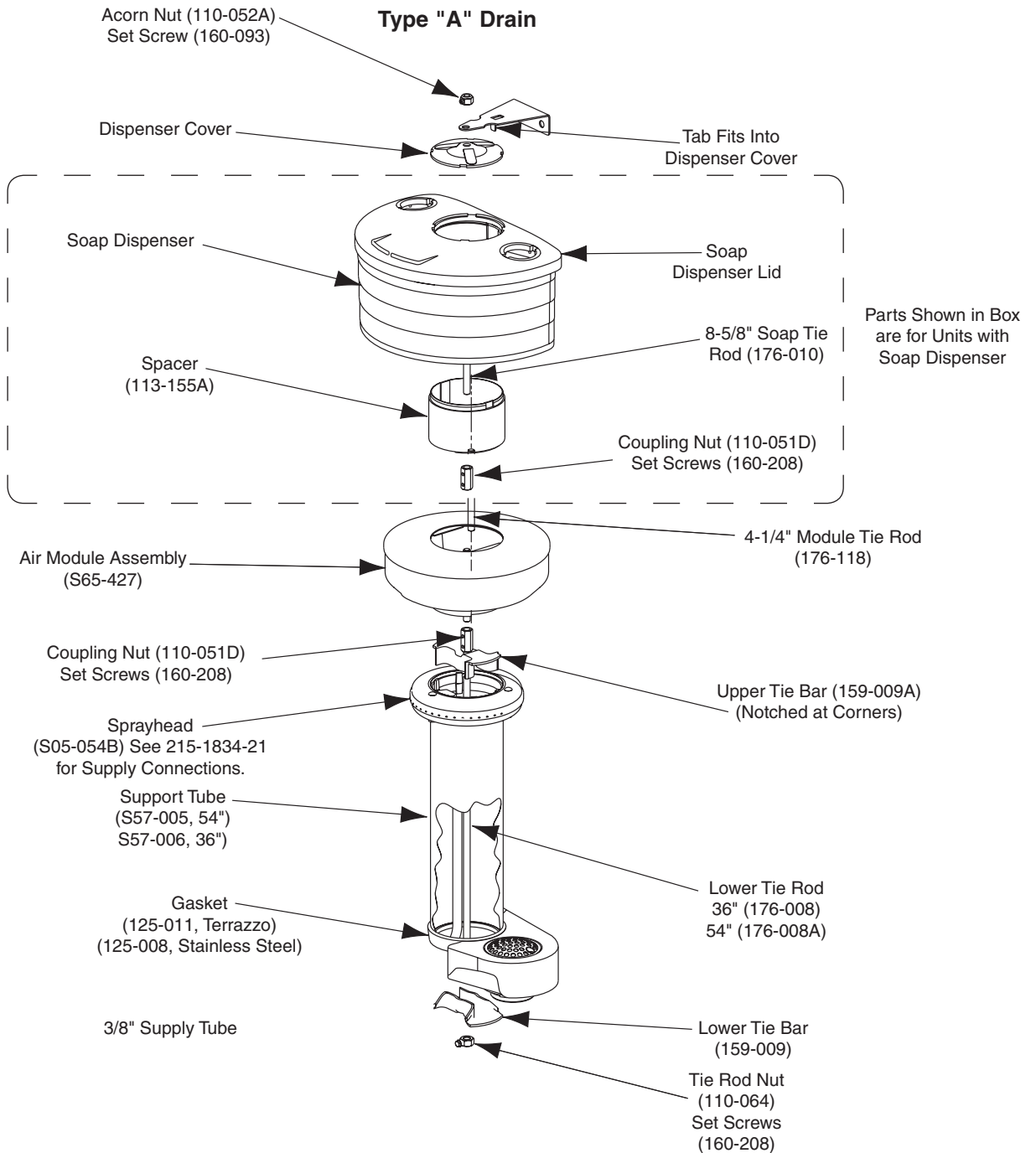



## 1b Air Metering Valve Assembly for B Drain and H Drain Units

- A** Install hemmed end (not sharp end) of support tube with gasket onto bowl. Connect 1/2" dia. tubing to sprayhead.
- Using a sharp razor, cut tubing squarely and remove any burrs. DO NOT pinch or crush end of tubing.
  - Loosen nut on fitting. Moisten end of tube and push into fitting until it is firmly seated. Tighten nut to secure tube to fitting (make sure nut is securely tightened).
  - If connector leaks, reseal tubing according to above procedure. If leaking persists, replace male connector, or call your Bradley representative for assistance.

**B** Place sprayhead with 1/2" tubing onto support tube. Run the tubing down through the support tube and connect to valve tube connector.

**C** Place the air metering module assembly on top of sprayhead. Run 1/8" diameter tubing through the support tube down into the pedestal and connect to the air valves, taking care that each sprayhead section's 1/2" supply tube and 1/8" activation button tube are connected to the same valve (see detail in Step 2).

**D** Insert the 1-1/2" vent pipe (supplied by installer) through the air module, sprayhead and support tube. Connect to vented trap provided.



*Skip to step F for units without soap.*

**E** For units with soap option, install the spacer, soap dispenser and cover in position on top of air module. Slide tie bar over 1-1/2" vent pipe 1/2" below top of soap dispenser lid and secure with set screws. Slide the dispenser cover over 1-1/2" vent pipe and secure with 2 screws included with tie bar.

**F** Slide tie bar over 1-1/2" vent pipe 1/2" below top of air module cover and secure with set screws. Slide the dispenser cover 1-1/2" vent pipe and secure with 2 screws included with tie bar.

**G** Connect vent pipe to vent through ceiling with pipe union.

**H** **FOR B UNIT:** Install 1/2" nominal copper tubing supply lines (pass them through holes in cover down through support column) and connect to stops using suitable fittings.



# Air Metering Activation Modules - Non-Sectional Semi-Circular Washfountains WF2603, WF2604, WF2703, WF2704

P.O. Box 309 • Menomonee Falls, WI 53052-0309 • 1 800 BRADLEY • 262 251 6000 • bradleycorp.com

## 1b Air Metering Valve Assembly for B Drain and H Drain Units

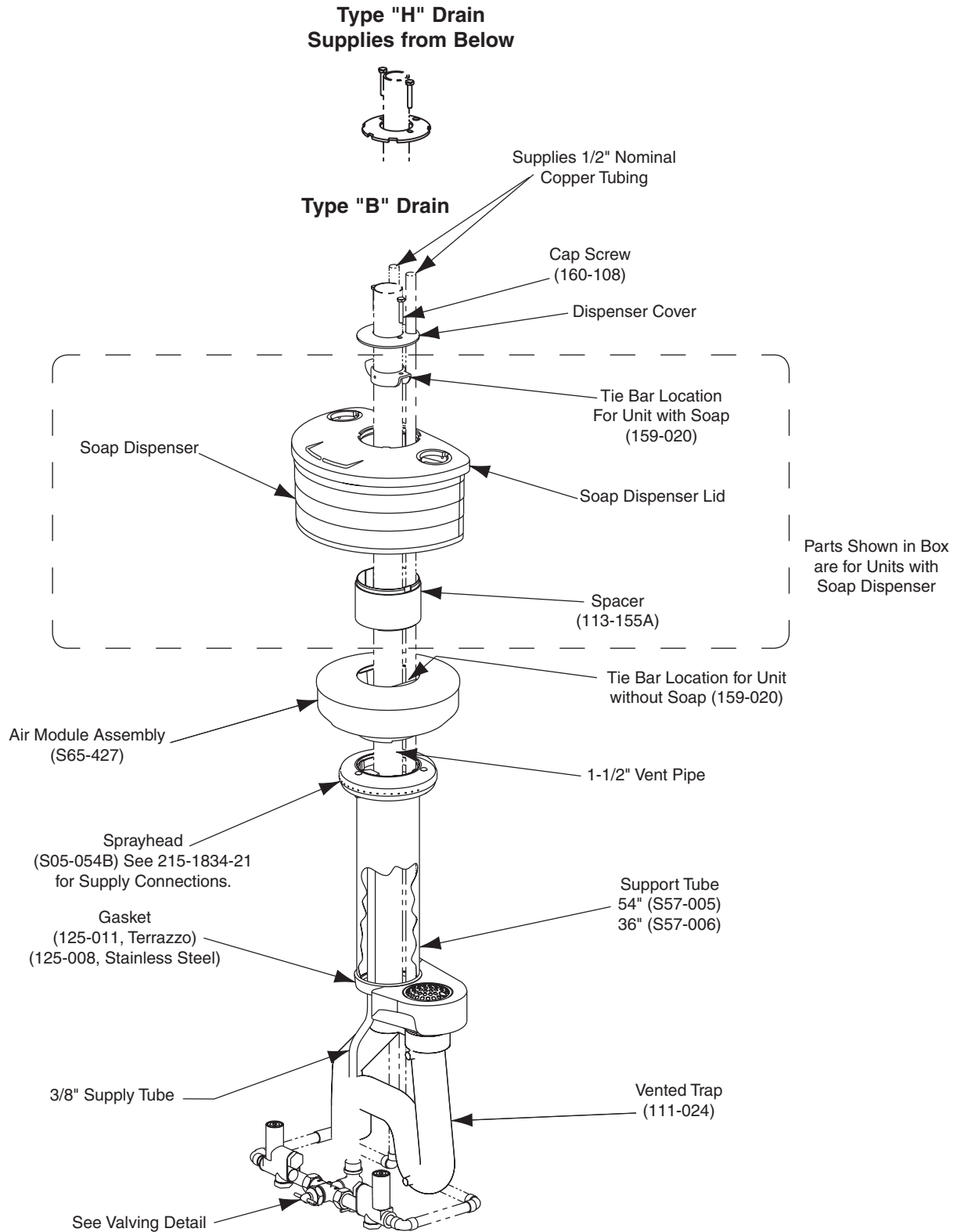



## 2 Connect Valve and Tubing for Non-Sectional Air Metering Activation



*Flush supply lines before making connections.*

**A** Connect 3/8" dia. tubing to tee and ball valve, two places. The male connector for the valve assembly will remain tight and leakproof when tubing is cut and installed properly. Follow the procedures below when installing tubing to ensure that you achieve a leakproof seal.

- Using a sharp razor, cut tubing squarely and remove any burrs. **DO NOT** pinch or crush end of tubing.
- Loosen nut on fitting. Moisten end of tube and push into fitting until it is firmly seated. Tighten nut to secure tube to fitting (make sure nut is securely tightened).
- If connector leaks, reseal tubing according to above procedure. If leaking persists, replace male connector, or call your Bradley representative for assistance.

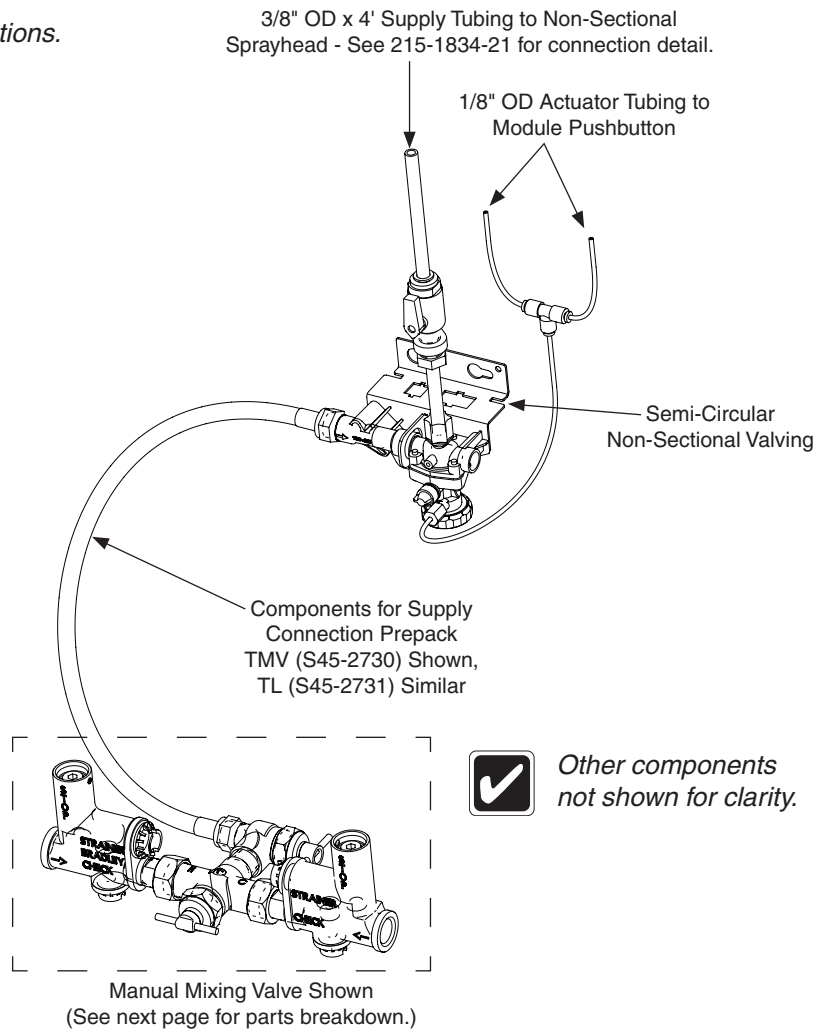



# Air Metering Activation Modules - Non-Sectional Semi-Circular Washfountains WF2603, WF2604, WF2703, WF2704

P.O. Box 309 • Menomonee Falls, WI 53052-0309 • 1 800 BRADLEY • 262 251 6000 • bradleycorp.com

## 2 Connect Valve and Tubing for Non-Sectional Air Metering Activation (Cont...)

**B** Hang valve assembly on pedestal bracket. Use included #10-24 screws to secure.

**C** Use wire tie to secure valving to valve bracket.

**D** Connect the stop-strainer-check valves and mixing valve to the supplies as shown. Use pipe sealant to seal threads.

For "A" and "H" units skip steps E through G.

**E** For overhead supply, install 1/2" nominal copper supply tubing by passing lines through holes in the dispenser cover and then down through the support tube.

**F** Using suitable fittings, install the complete valving assembly to the supplies as shown at the approximate height indicated in table.

**G** Connect one end of the flexible supply hose to the mixing valve and the other end to the gang valve.

**H** When tubing connections are complete, angle volume control valve is to be used as volume control to control spray pattern from sprayhead. Also verify that each activation button activates corresponding sprayhead section.

Bowl, tubing and supplies not shown for clarity.

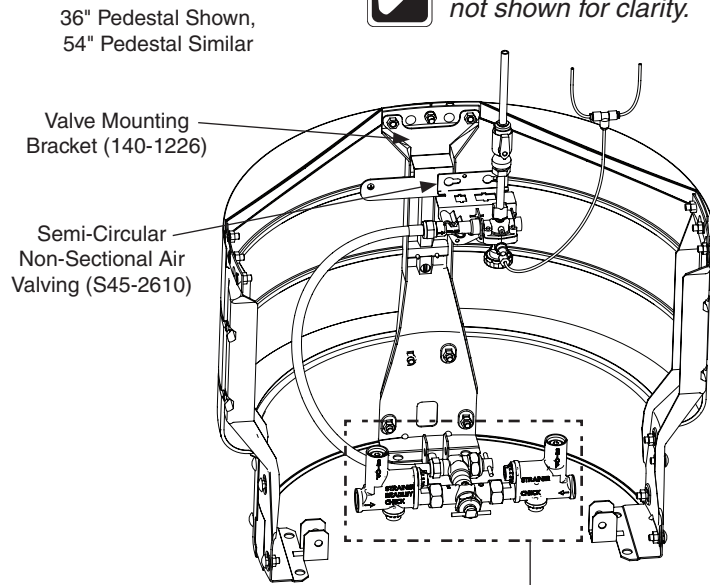

Manual mixing valve shown.

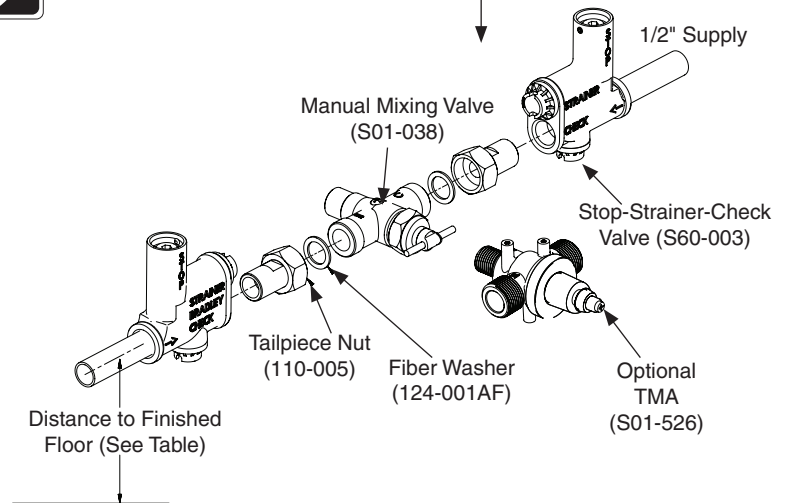

Distance from 1/2" Supply to Finished Floor				
Model	Type A	Type B	Type O	Type H
Standard Height	9" (229mm)	6-3/16" (157mm)	9" (229mm)	6-3/16" (157mm)
Juvenile Height	5-1/4" (133mm)	3-7/16" (87mm)	5-1/4" (133mm)	3-7/16" (87mm)



# Air Metering Activation Modules - Non-Sectional Semi-Circular Washfountains WF2603, WF2604, WF2703, WF2704

P.O. Box 309 • Menomonee Falls, WI 53052-0309 • 1 800 BRADLEY • 262 251 6000 • bradleycorp.com

## 3 Turn on Water, Test and Adjust Unit

**A** Turn on water supply and check for leaks. Activate each pushbutton to purge air from the lines.

Check to make sure stop valves are open before turning on water.

**C** Turn the handle gently until desired water temperature is reached.

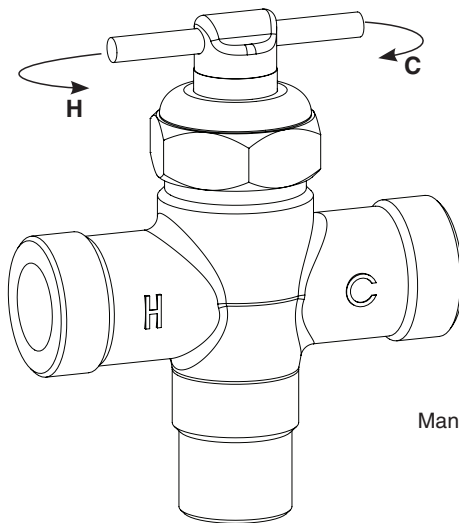

Manual Mixing Valve

**B** Adjust air-valve meter timing, if desired.

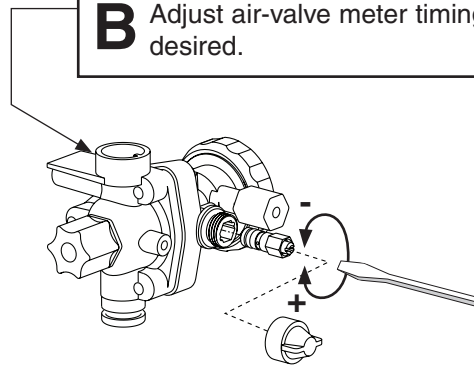

Air Metering Timer

On units ordered with optional TMA, these valves are NOT factory preset. Upon installation, the temperature of these mixing valves must be checked and adjusted to ensure delivery of a safe water temperature. Water in excess of 110°F (43°C) may cause scalding.

## Air Metering Module Components

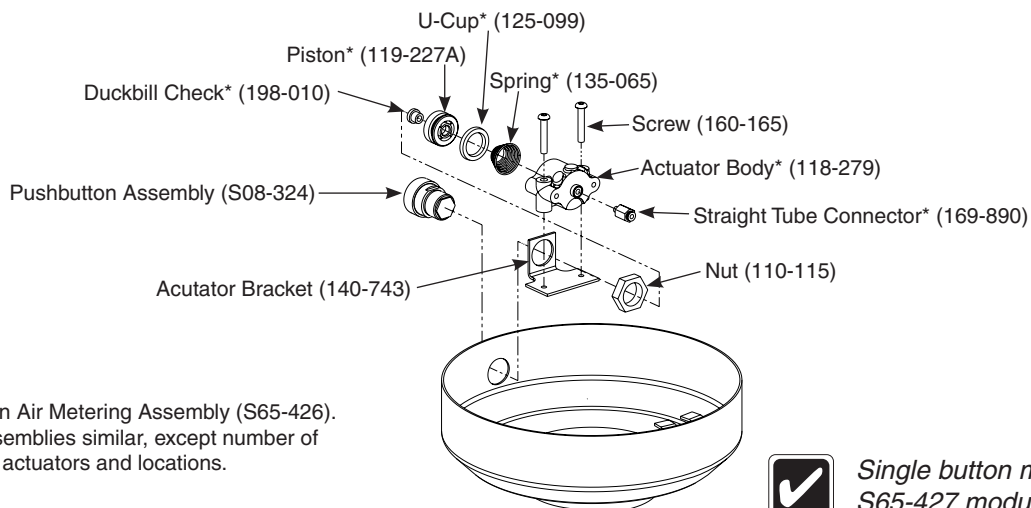

\* Included in Air Metering Assembly (S65-426). Other assemblies similar, except number of actuators and locations.

Single button module shown. S65-427 module has 2 buttons.



## Metering Air Valve Maintenance

- ✓
 The air valve timer is located next to the tube connector on the air valve body. The timer is capped with a filter to prevent dirt build-up on the timer. The air valve timing can be adjusted from 5–60 seconds.

## Adjust Air Valve Meter Time

**A** Remove filter cap and use a screwdriver to tighten or loosen the timer (see illustration at right). Turning the timer clockwise increases the time; turning the timer counterclockwise decreases the time.

**B** Continue to adjust until the timer is set at desired length.

**C** Replace filter cap over the timer.

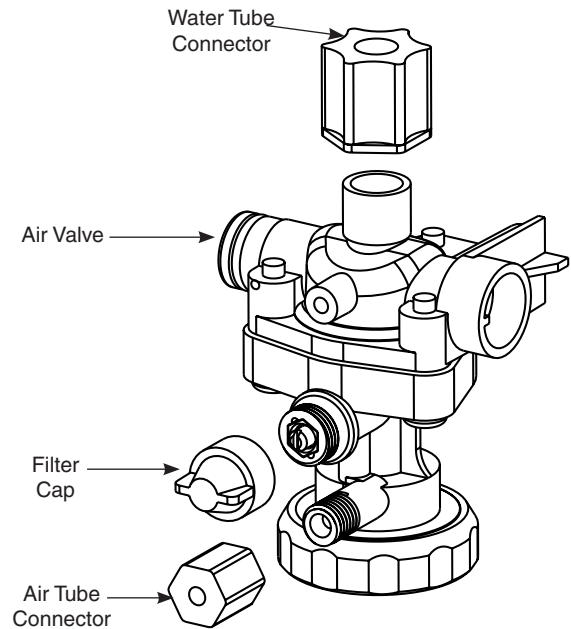

## Tube Connection Leaks

**A** Push in the orange manual release button while pulling the tube out (see illustration at right) to disconnect the tube at the connector. No tools are needed.

**B** To correct a leak, press tubing firmly into the connector and make sure it is seated.

**C** If leak persists, remove tubing from the fitting, and trim the tubing end square with a razor-sharp knife. If leak continues, replace the fitting or contact your Bradley representative for assistance.

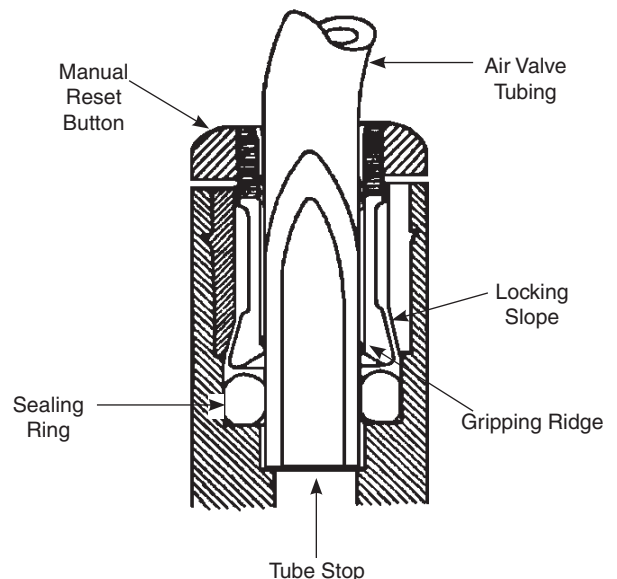





## AST4 Valve Repair Kits

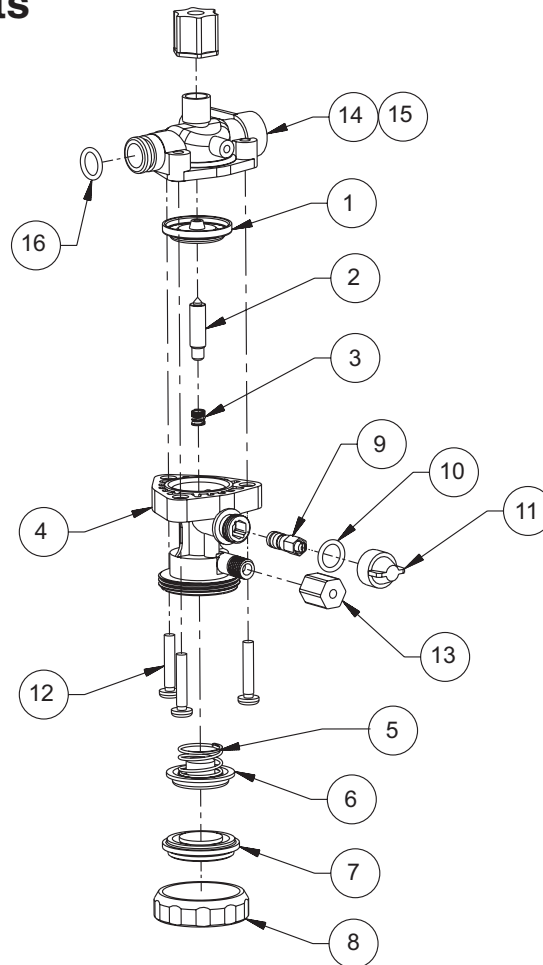

## AST4 Valve Repair Kits

Item	Description	AST 4 Valve Kit S65-260	Repair Kit (Upper) S65-261	Repair Kit (Lower) S65-262	AST4 1/4" Tube Valve S07-078S	AST4 1/4" Tube Valve S07-078AS
		Qty				
1	Diaphragm	1	—	1	1	1
2	Armature	1	—	1	1	1
3	Spring	1	—	1	1	1
4	AST 4 Valve Upper Body	1	—	—	1	1
5	Spring	1	1	—	1	1
6	Magnet / Diaphragm Assembly	1	1	—	1	1
7	AST 4 Valve Cover	1	1	—	1	1
8	AST 4 Valve Clamp Nut	1	1	—	1	1
9	AST 4 Valve Timer Assembly	1	—	—	1	1
10	O-Ring, #2-012	1	—	—	1	1
11	AST 4 Valve Timer Cover	1	—	—	1	1
12	Screw, #8 x 7/8"	3	—	—	1	1
13	Compression Nut, 1/8" Tube	1	1	—	1	1
14	Valve Body 1/4 Tube, Closed	—	—	—	1	—
15	Valve Body 1/4 Tube, Thru	—	—	—	—	1
16	O - Ring	—	—	—	1	1



## Troubleshooting – Metering Air Valve



Turn off water supplies to the unit before troubleshooting.

Item	Qty.	Description
1	1	Diaphragm
2	1	Armature
3	1	Spring
4	1	AST 4 Valve Upper Body
5	1	Spring
6	1	Magnet/Diaphragm Assembly
7	1	AST 4 Valve Cover
8	1	AST 4 Valve Clamp Nut
9	1	AST 4 Valve Timer Assembly
10	2	O-Ring
11	1	AST 4 Valve Timer Cover
12	3	Screw, #8 x 7/8"
13	1	Compression Nut, 1/8" Tube
14	1	Compression Nut, 5/16" Tube
15	1	O-Ring

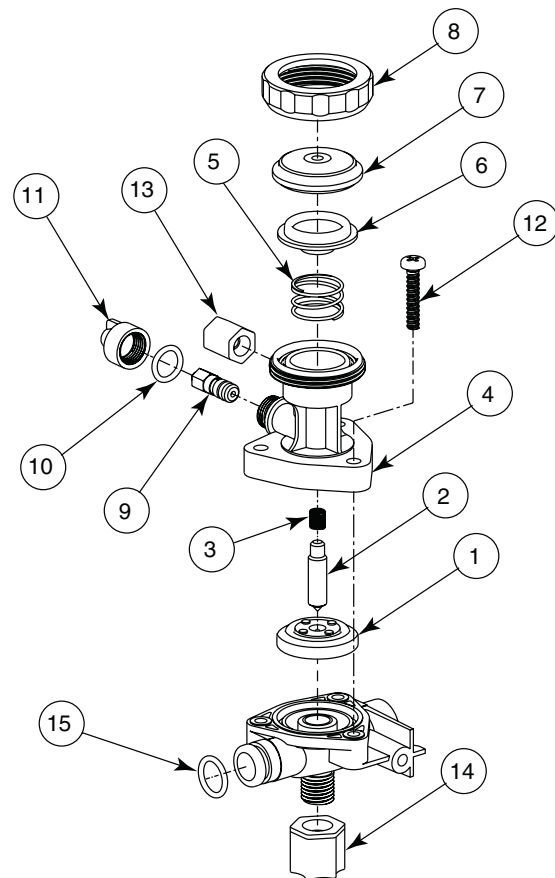

Problem	Cause	Solution
Valve will not shut off.	Timing mechanism is clogged.	Clean and inspect timing mechanism: 1. If compressed air is available, blow water and debris from timer cover of timing mechanism. 2. Turn adjusting screw out all the way. Clean and inspect screw and valve body. 3. Turn adjusting screw in to desired cycle time.
Valve will not turn on.	Water is not being supplied to unit.	Open all stops on mixing valve.
	Water pressure is over 80 PSI.	Install a pressure reducing valve.
	Failed diaphragm/magnet assembly.	Unscrew the valve clamp nut on valve. Remove valve cover. Gently press the diaphragm. The valve should activate. If not, replace the diaphragm/magnet assembly.
Timing can not be adjusted for more than 5 seconds.	There is an air leak.	Check the valve assembly: 1. Check all tubing and fittings for proper assembly. 2. Tighten cap and nut on 1/8" tubing.
Pushbutton does not work properly.	Air volume may not be sufficient to operate valve.	Check for leaks and lubricate U-cup: 1. Check all fittings for air leaks. 2. Disassemble pushbutton and lubricate U-cup seal (see pushbutton assembly diagram).
Water is dripping from the streamformers.	Debris has accumulated on valve seat or orifices.	Clean and inspect valve seat: 1. Remove screws and disassemble metering valve. 2. Clean valve seat and inspect for deep gouges or scratches. Replace valve body if necessary. 3. Remove any debris clogging off-center hole in rubber diaphragm.