

Residential Powerful Compact[®] Electric Water Heater

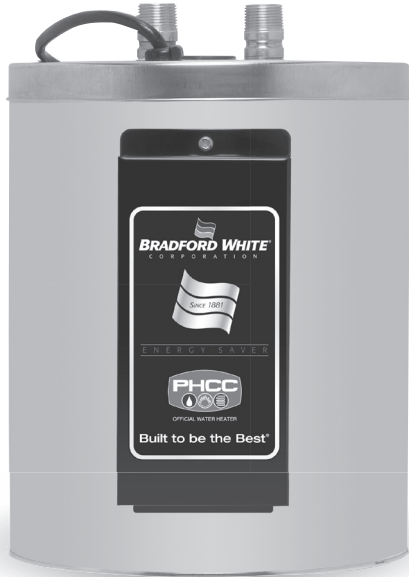

Photo is of
RE1-2U6

The Residential Electric Model Features:

- **Compact Design**— Can be mounted almost anywhere - under a sink, inside cabinets or hung on a wall.
- **Fully Automatic Thermostat Controls**—Fast acting surface-mount thermostat with high limit energy cut-off (manual reset) for safety.
- **Direct Heat Transfer with Immersed Element**—Transfers heat directly and efficiently to the water. Screw-in style.
- **Vitraglas[®] Lining with Microban[®]**—An exclusively engineered enamel formula that provides superior tank protection from the corrosive effects of water; and with Microban[®] antimicrobial product protection to help prevent the growth of bacteria, mold and mildew on the surface of the tank lining.
- **Insulation System**—Non-CFC foam precast surrounds tank.
- **Water Connections**—3/4" (19mm) NPT factory-installed true dielectric fittings extend water heater life and simplify water line connections.
- **Protective Anode Rod**—Provides added protection against corrosion for long-term, trouble-free service.
- **Steel Tank**—Heavy gauge steel automatically formed, rolled, and welded.
- **Steel Jacket**—With special coating that inhibits rust and corrosion.
- **T&P Relief Valve**—Included.

Optional Feature:

- **Wall Mounting Bracket.**

FEATURING:

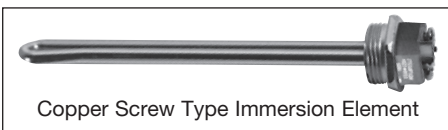

6 or 10-Year Limited Tank Warranties / 6 or 10-Year Limited Warranty on Component Parts.

For more information on warranty, please visit www.bradfordwhite.com

For products installed in USA, Canada, and Puerto Rico. Some states do not allow limitations on warranties. See complete copy of the warranty included with the heater.

Microban[®] antimicrobial product protection helps prevent the growth of bacteria, mold and mildew that may affect the product. The built-in antimicrobial properties do not protect users or others from disease-causing organisms. Microban[®] is a registered trademark of Microban Products Company.



Residential Powerful Compact® Electric Water Heater

Powerful Compact® Model

Meet or exceed ASHRAE 90.1 (latest edition).

Model Number	Rated Nominal Volume		Recovery at 90°F Rise*		A Floor to Top of Heater	B Jacket Dia.	C Floor to Water Conn.	D C/L of Water Conn.	G Water Conn. NPT	Approx. Shipping Weight
	U.S. Gal.	Imp. Gal.	U.S. GPH	Imp. GPH	in.	in.	in.	in.	in.	lbs.
RE1-2U6	2	1.7	7	6	12	9 ¹⁵ / ₁₆	12 ³ / ₄	2 ⁵ / ₈	³ / ₄	13

Model Number	Rated Nominal Volume		Recovery at 50°C Rise*		A Floor to Top of Heater	B Jacket Dia.	C Floor to Water Conn.	D C/L of Water Conn.	G Water Conn. NPT	Approx. Shipping Weight
	Liters	Liters/ Hour	mm.	mm.	mm.	mm.	mm.	mm.	mm.	kg.
RE1-2U6	7	26	305	252	324	67	19	6	6	

Includes a 4ft. cord with 3 prong grounded plug (20 amp circuit required).

For 10 year models, change suffix "6" to "10".

Single element only.

* Based on 1500W operation.

Only available as 120V / 1500W.

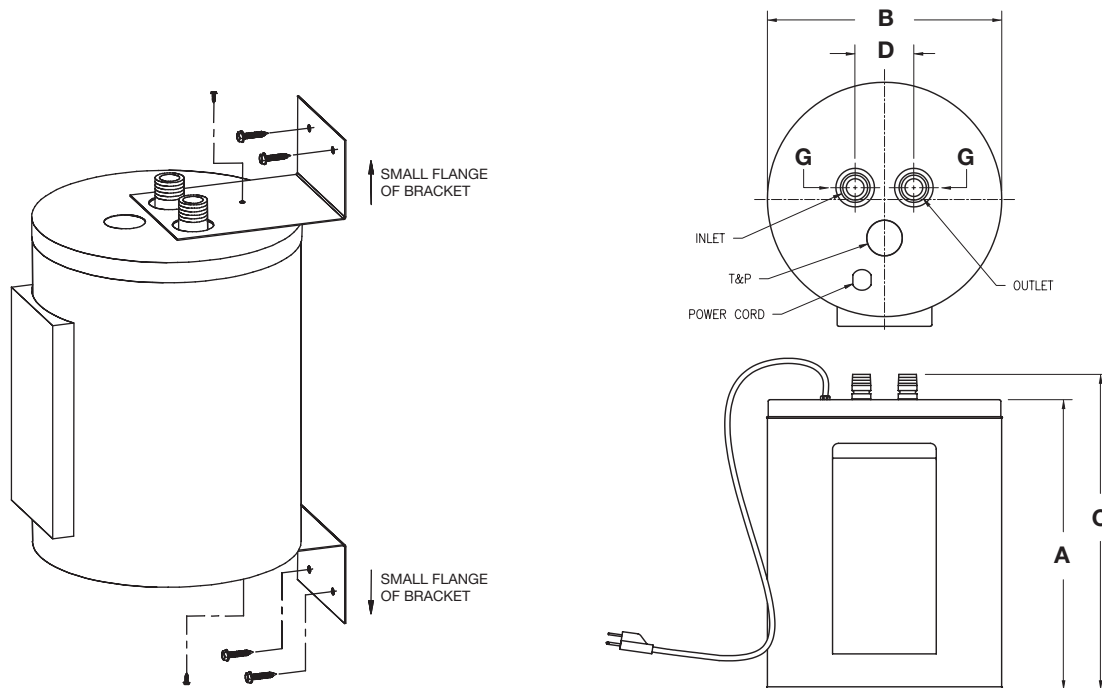

Optional Wall Mounting Bracket (2 brackets)
Part Number 265-45018-00

General

All models are exempt from NAECA requirements and ASHRAE Standard 90.1b. All models UL® listed. All water connections, 3/4" (19mm) NPT. T&P connection, 3/4" (19mm) NPT female. All models certified at 300 psi test pressure (2068 kPa) and 150 psi working pressure (1034 kPa).

Dimensions and specifications subject to change without notice in accordance with our policy of continuous product improvement.

— BRADFORD WHITE IS —

AMERICAN STRONG

Sales: 800-523-2931 ■ Fax 215-641-1612

24/7 Technical Support: 800-334-3393 ■ Email techserv@bradfordwhite.com

Products made by Bradford White are manufactured in the United States using the finest raw materials and components from around the world.

Built to be the Best®