

ElectriFLEX HD™ (Heavy-Duty) Commercial Electric Water Heater



Photo is of
CEHD50(kW)3*CF

Bradford White ElectriFLEX HD™ Electric Models Feature:

- **Immersion Thermostats** —Designed to provide outlet water at a thermostatically controlled temperature greater than 180°F (82°C).
- **Conversion Kits**—Design certified by UL® for field conversion. Conversion kits are available to convert any one model to a variety of voltages and kW inputs (Kit part numbers on reverse side). All models are shipped from the factory standard Three Phase, and can be field converted to Single Phase without a conversion kit.
- **Insulation System**—3" (76mm) Non-CFC foam covers the sides and top of the tank, reducing heat loss. This results in less energy consumption, improved efficiencies, and jacket rigidity.
- **Vitraglas® Lining with Microban®**—An exclusively engineered enamel formula that provides superior tank protection from the corrosive effects of water; and with Microban® antimicrobial product protection to help prevent the growth of bacteria, mold and mildew on the surface of the tank lining.
- **Hydrojet® Sediment Reduction System**—Sediment build-up reducing device that also increases first hour delivery of hot water while minimizing temperature build-up in tank.
- **Water Connections**—1½" (38mm) NPT factory-installed true dielectric fittings extend water heater life and simplify water line connections.
- **Elements**—Screw in style low watt density incoloy sheathed elements standard. These elements are durable and resistant to lime buildup.
- **Two Protective Anode Rods**—Provide added protection against corrosion for long-term, trouble-free service.
- **Hand Hole Cleanout**—Allows inspection of tank interior and facilitates the removal of sediment deposits.
- **ASME Construction Available.**
- **NSF Kits Available.**
- **Low Restrictive Brass Drain Valve**—Durable tamper proof design.
- **T&P Relief Valve**—Installed.
- **Completely Pre-wired**—With pressure lug terminal block eliminating need for splicing or taping of wires.
- **Voltages Available**—208v, 240v, 277v, 380v, 415v, 480v and 600v.
- **Internal Fusing**—Standard on all models.

FEATURING:



3 or 5-Year Limited Tank Warranties / 1-Year Limited Warranty on Component Parts.

For more information on warranty, please visit www.bradfordwhite.com

For products installed in USA, Canada, and Puerto Rico. Some states do not allow limitations on warranties. See complete copy of the warranty included with the heater.

Microban® antimicrobial product protection helps prevent the growth of bacteria, mold and mildew that may affect the product. The built-in antimicrobial properties do not protect users or others from disease-causing organisms. Microban® is a registered trademark of Microban Products Company.

Commercial Electric Water Heater

ElectriFLEX HD™ Electric Models

Model Number	Rated Nominal Capacity		A	B	C	E	F	G	J	Water Conn. NPT	Approx Shipping Weight lbs.	
	U.S. Gal.	Imp. Gal.	Floor to Top of Heater in.	Jacket Dia. in.	Floor to Hot Water Conn. in.	Floor to C/L of Cold Water Conn. in.	Floor to T&P Conn. in.	Floor to Top of Control Box in.	C/L of Hot Water Conn. in.		in.	Std.
CEHD50(A)(KW)3*CF	50	42	50 7/16	24	52 5/8	6 15/16	40 11/16	49 1/8	12	1 1/2	270	302
CEHD80(A)(KW)3*CF	80	67	61 1/4	26	65 1/2	7	52 3/16	49 1/8	13	1 1/2	335	378
CEHD120(A)(KW)3*CF	119	100	64 11/16	30 1/4	66 3/4	6 15/16	54 3/4	50 5/8	15 1/8	1 1/2	430	485

Model Number	Rated Nominal Capacity		A	B	C	E	F	G	J	Water Conn. NPT	Approx Shipping Weight kg.	
	Liters		mm.	mm.	mm.	mm.	mm.	mm.	mm.		mm.	Std.
CEHD50(A)(KW)3*CF	189		1281	610	1337	176	1033	1248	308	38	122	137
CEHD80(A)(KW)3*CF	303		1556	660	1664	178	1326	1248	330	38	152	171
CEHD120(A)(KW)3*CF	450		1643	768	1695	176	1391	1337	384	38	195	220

* = voltage and phase designator. Voltage and phase must be specified when ordering. Example: CEHD50123*CF, 240 Volt, 3 phase.

(A) ASME Construction available. For ASME construction add "A" to the model number. Example: CEHD50A123*CF.

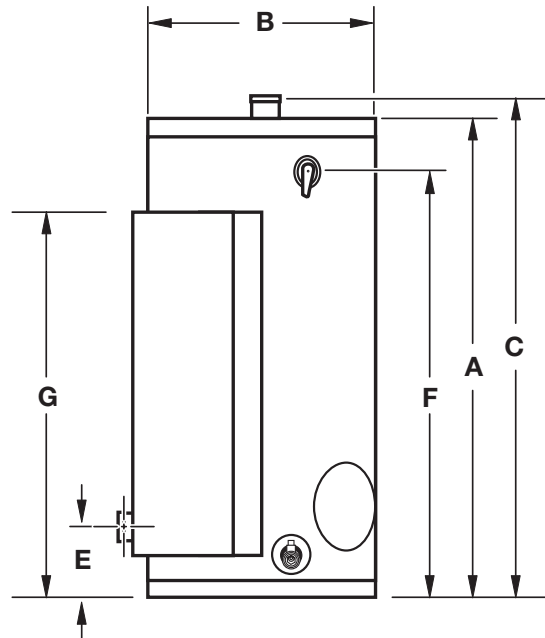
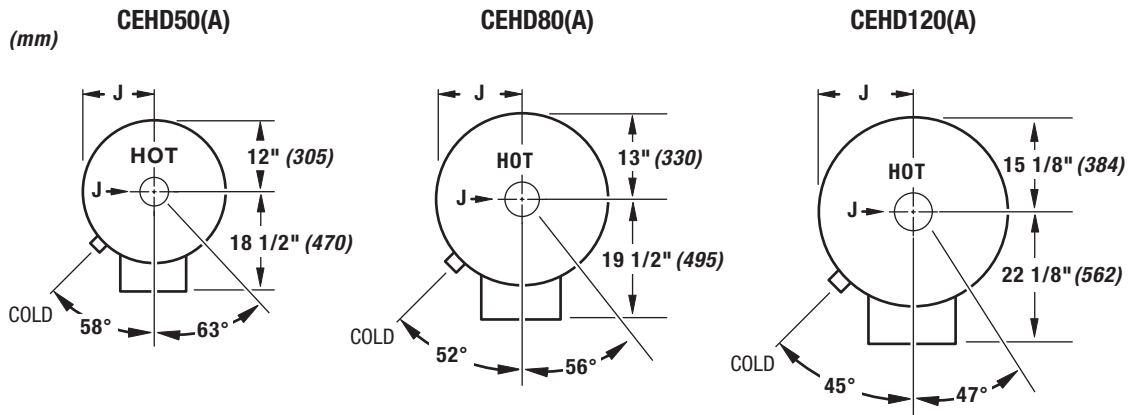

Commercial Electric Water Heater

Model	Desired Input		Conversion Kit Part Numbers***						
	Total kW	Element kW	208 Volts	240 Volts	277 Volts	380 Volts	415 Volts	480 Volts	600 Volts*
CEHD with 3 Elements	6	2	415-51043-73	415-51043-61	415-51043-49	415-51043-37	415-51043-25	415-51043-85	415-51043-01
	9	3	415-51043-74	415-51043-62	415-51043-50	415-51043-38	415-51043-26	415-51043-14	415-51043-02
	12	4	415-51043-128	415-51043-63	415-51043-51	415-51043-104	415-51043-94	415-51043-15	415-51043-03
	13.5	4.5	415-51043-129	415-51043-64	415-51043-114	415-51043-105	415-51043-95	415-51043-86	415-51043-04
	15	5	415-51043-130	415-51043-122	415-51043-115	415-51043-106	415-51043-96	415-51043-87	415-51043-05
CEHD with 6 Elements	18	6	415-51043-131	415-51043-123	415-51043-116	415-51043-107	415-51043-97	415-51043-88	415-51043-06
	24	4	415-51043-132	415-51043-67	415-51043-55	415-51043-108	415-51043-98	415-51043-19	415-51043-07
	27	4.5	415-51043-133	415-51043-68	415-51043-117	415-51043-109	415-51043-99	415-51043-89	415-51043-08
	30	5	415-51043-134	415-51043-124	415-51043-118	415-51043-110	415-51043-100	415-51043-90	415-51043-09
CEHD with 9 Elements	36	6	415-51043-135	415-51043-125	415-51043-119	415-51043-111	415-51043-101	415-51043-91	415-51043-10
	45	5	415-51043-136	415-51043-126	415-51043-120	415-51043-112	415-51043-110	415-51043-92	415-51043-11
	54	6	415-51043-137**	415-51043-127	415-51043-121	415-51043-113	415-51043-103	415-51043-93	415-51043-12

3 element models may convert 6 kW thru 18 kW ONLY

6 element models may convert 24 kW thru 36 kW ONLY

9 element models may convert 45 kW thru 54 kW ONLY

*** Converting 3 Element Configurations (6-18kW)			*** Converting 6 or 9 element configurations (24-54kW)		
From	To	Transformer Required	From	To	Transformer Required
208/240/480 Volt	277/380/415 Volt	415-41994-02	208/240/480 Volt	277/380/415 Volt	415-41995-02
277/380/415 Volt	208/240/480 Volt	415-41994-01	277/380/415 Volt	208/240/480 Volt	415-41995-01
208/240/480 Volt	208/240/480 Volt	No Transformer Change Required	208/240/480 Volt	208/240/480 Volt	No Transformer Change Required
277/380/415 Volt	277/380/415 Volt	No Transformer Change Required	277/380/415 Volt	277/380/415 Volt	No Transformer Change Required

* Only kW conversion is allowed for models rated 600V. Models rated 480V and below must not be converted to 600V.

** Only available as a three phase conversion kit.

Input kW	Recovery GPH Temperature Rise °F									Input kW	Recovery LPH Temperature Rise °C								
	40	50	60	70	80	90	100	120	140		23	28	34	40	45	50	56	67	78
6	62	50	41	35	31	28	25	21	18	6	235	189	155	132	117	106	95	79	68
9	93	74	62	53	47	42	37	31	27	9	352	280	235	201	178	159	140	117	102
12	124	99	83	71	62	55	50	41	35	12	469	375	314	269	235	208	189	155	132
13.5	140	112	93	80	70	62	56	47	40	13.5	530	424	352	303	265	235	212	178	151
15	155	124	103	89	78	69	62	52	44	15	587	469	390	337	295	261	235	197	167
18	186	149	124	106	93	83	74	62	53	18	704	564	469	401	352	314	280	235	201
24	248	199	164	142	124	110	99	83	71	24	939	753	621	538	469	416	375	314	269
27	279	223	186	160	140	124	112	93	80	27	1056	844	704	606	530	469	424	352	303
30	310	248	207	177	155	138	124	103	89	30	1173	939	784	670	587	522	469	390	337
36	372	298	248	213	186	165	149	124	106	36	1408	1128	939	806	704	625	564	469	401
45	465	372	310	266	233	207	186	155	133	45	1760	1408	1173	1007	882	784	704	587	503
54	558	447	372	319	279	248	223	186	160	54	2112	1692	1408	1208	1056	939	844	704	606

Number of Elements														
Input kW	208V Phase		240V Phase		277V Phase		380V Phase		415V Phase		480V Phase		600V Phase	
	1	3	1	3	1	3	1	3	1	3	1	3	1	3
6	3	3	3	3	3	3	3	3	3	3	3	3	3	3
9	3	3	3	3	3	3	3	3	3	3	3	3	3	3
12	3	3	3	3	3	3	3	3	3	3	3	3	3	3
13.5	3	3	3	3	3	3	3	3	3	3	3	3	3	3
15	3	3	3	3	3	3	3	3	3	3	3	3	3	3
18	3	3	3	3	3	3	3	3	3	3	3	3	3	3
24	6	6	6	6	6	6	6	6	6	6	6	6	6	6
27	6	6	6	6	6	6	6	6	6	6	6	6	6	6
30	6	6	6	6	6	6	6	6	6	6	6	6	6	6
36	6	6	6	6	6	6	6	6	6	6	6	6	6	6
45	9	9	9	9	9	9	9	9	9	9	9	9	9	9
54	9	9	9	9	9	9	9	9	9	9	9	9	9	9

3 element models may convert 6 kW thru 18 kW ONLY

6 element models may convert 24 kW thru 36 kW ONLY

9 element models may convert 45 kW thru 54 kW ONLY

Full Load Current Amperes														
Input kW	208V Phase		240V Phase		277V Phase		380V Phase		415V Phase		480V Phase		600V Phase	
	1	3	1	3	1	3	1	3	1	3	1	3	1	3
6	28.8	16.6	25.0	14.4	21.6	10.0	9.0	12.5	7.2	5.8				
9	43.2	25.0	37.2	21.6	32.4	14.0	13.0	18.7	10.8	8.7				
12	57.6	33.3	50.0	28.9	43.3	19.0	17.0	25.0	14.4	11.5				
13.5	64.9	37.5	56.2	32.5	48.7	21.0	19.0	28.1	16.2	13.0				
15	72.1	41.6	62.5	36.1	54.1	23.0	21.0	31.2	18.0	14.4				
18	86.5	50.0	72.0	43.4	64.0	28.0	25.0	37.5	21.6	17.3				
24	115.4	66.7	100.0	57.8	86.6	37.0	34.0	50.0	28.9	23.1				
27	129.8	75.0	112.5	65.0	97.4	41.0	38.0	56.2	32.5	26.0				
30	144.2	83.3	125.0	72.2	108.3	46.0	42.0	62.5	36.1	28.9				
36	173.0	100.0	150.0	86.7	129.9	55.0	50.0	75.0	43.3	34.6				
45	216.3	125.0	187.5	108.3	162.4	69.0	63.0	93.7	54.1	43.3				
54	259.6	150.0	225.0	130.0	194.9	83.0	75.0	112.5	65.0	52.0				

Sample Specification

The water heater shall be a Bradford White ElectriFLEX HD™ model with a rated storage capacity of not less than _____ gallons (_____ liters), a minimum kW input of _____ kW (_____ BTU/Hr.), a minimum recovery of _____ GPH (_____ LPH). The tank shall be lined with Vitraglas® vitreous enamel with Microban® antimicrobial technology and have a bolted hand hole cleanout. The tank shall have _____ anode rods installed in separate tank head couplings. The heater shall have 3" Non-CFC foam insulation, and come equipped with an ASME rated T&P relief valve, a cold water inlet Hydrojet® Sediment Reduction System. It shall be design certified by UL® for 180°F (82°C) application, either with or without a separate storage tank, and comply with state and local codes and ordinances.

General

All electric water heaters are certified at 300 PSI test pressure (2068 kPa) and 150 PSI working pressure (1034 kPa). All models are design certified by UL®, to provide outlet water at a thermostatically controlled temperature greater than 180°F (82°C) as an Automatic Storage Heater, and an Automatic Circulating Tank Heater. As an Automatic Storage Heater, all models are complete, self-contained water heating systems. It needs no separate storage tank, pump, wiring or elaborate piping network. When equipped with a mixing valve, it will supply 180°F (82°C) sanitizing and lower temperature general purpose hot water simultaneously. These models can be used either as a single unit or in multiples connected in series or parallel (recommended). ***Dimensions and specifications subject to change without notice in accordance with our policy of continuous product improvement.***

Customer Service / Sales: 1-866-690-0961 / 905-203-0600
24/7 Technical Support: 800-334-3393 ■ Email techserv@bradfordwhite.com

Built to be the Best®