



Suction Diffuser Plus

Centrifugal Pump Accessories

B-820H



Bell & Gossett
a xylem brand

The new Bell & Gossett Suction Diffuser Plus



The new Bell & Gossett Suction Diffuser Plus enables the pumping system to function at the most optimum performance parameters. It conditions the flow into the pump suction to ensure the highest pump efficiency. In addition it saves space by eliminating the need for straight lengths of pipe leading into the pump while serving as an elbow to facilitate a close transition between return piping and the pump suction. The large orifice cylinder serves as a coarse y-strainer to prevent large sediment or debris from entering the pump. Finally the internals are all completely removable making field service fast and easy.

The B&G Suction Diffuser Plus includes our Flow Cone (U.S. Patent #10, 240, 611), designed to eliminate the recirculation zones that develop in most suction diffuser designs available on the market today. These recirculation zones can lead to increased pressure drop across the suction diffuser and a high degree of variance in the velocity profile as flow enters the pump suction. The Flow Cone now directs the flow completely out of the suction diffuser and into the pump suction while also providing a more uniform velocity profile. As a result pump efficiency is more effectively retained and pumping system energy costs are reduced.

Bell & Gossett Suction Diffuser Plus offers these advantages:

- Flow Cone eliminates recirculation zones, directing flow toward the pump and improving flow conditioning
- Full length straightening vanes assure uniform flow pattern for pump inlet
- Large diameter orifice cylinder prevents debris from entering pump suction while maintaining low pressure drop.
- Fine mesh throwaway start-up strainer assures cleaner, more trouble free system
- Optional pressure/temperature ports permit checking of system conditions and verification of start-up strainer presence
- Eliminates the need for separate long radius elbows or reducing elbows
- Common installation dimensions compared to current B&G designs making retrofits easy
- Easily removable end cap with reusable o-ring
- Plug/blow down connection permits routine maintenance
- All Suction Diffusers are available in compliance with Buy American Act COTS provision

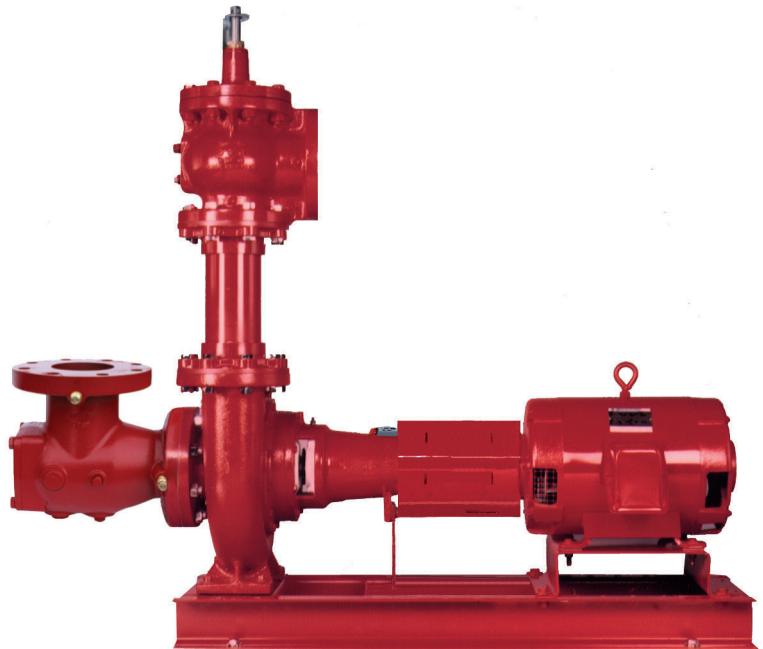

All new Flow Cone

Patented design provides greater pump efficiency retention

Velocity vector analysis of current Suction Diffuser designs showed a significant recirculation zone in the area opposite the pump suction, shown in **Figure 1**. This recirculation zone inhibited the complete flow of fluid into the pump suction, creating a high degree of variance in the velocity profile of the flow as it enters the pump, shown in **Figure 3**. It also resulted in a higher pressure drop through the Suction Diffuser.

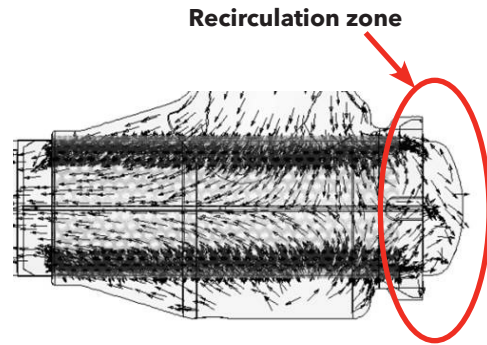

Figure 1
Velocity vectors in current designs

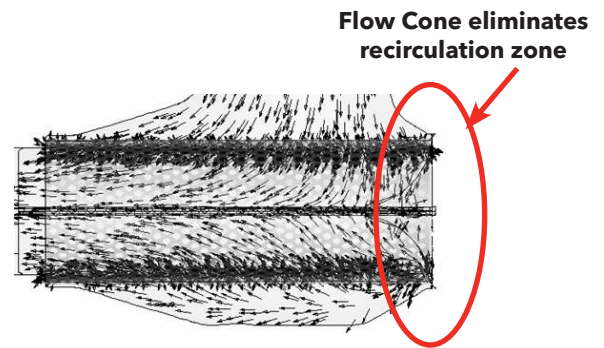

Figure 2
Velocity vectors in new Bell & Gossett design

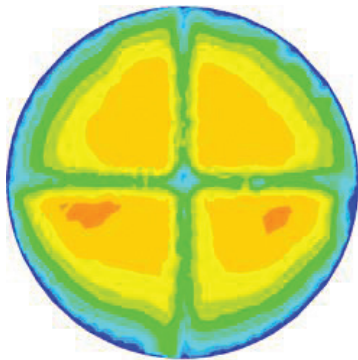

Figure 3
Flow uniformity at pump suction from current designs

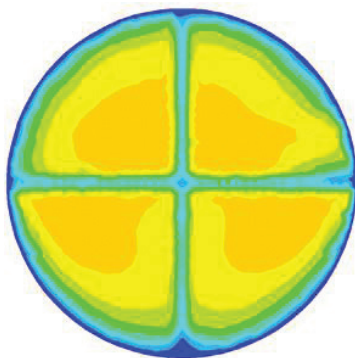
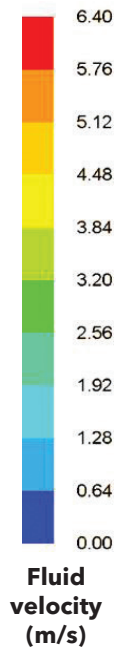

Figure 4
Flow uniformity at pump suction from new design



The Bell & Gossett Flow Cone eliminates the recirculation zone by removing the conditions that enable its development, as shown in **Figure 2**. **Figure 4** shows the improvement in velocity profile. There is much less variance at the pump which correlates to less stress on the pump impeller and shaft.

The improved fluid velocity profile and reduced stress allow the pump to retain more of its intrinsic efficiency, extending the life of the pump and lowering energy costs. Test results show the Suction Diffuser Plus provides as much as 2% efficiency retention over the previous Bell & Gossett Suction Diffuser design and as much as 5% efficiency retention over competitor Suction Diffuser models.

Suction Diffuser Plus

Centrifugal Pump Accessories

Construction

Body and cover plate: Cast iron
 Straightening vanes: X Type - Carbon steel
 Z Type - Stainless steel
 Orifice cylinder: X Type - Carbon steel
 Z Type - Stainless steel
 Start-up strainer: 16 mesh bronze
 O-Ring : EPDM

Maximum Working Pressure

175 psi (1,207 kPa)

Maximum Operating Temperature

250°F (121°C)

Dimensions, weights, and performance characteristics

Model	Dimensions in Inches (mm)										Cv	Weight in lbs (kg)
	System Side		Pump Side		A	B	C	D	E	F		
BA-3	2 (50.8)	T	1-1/2 (38.1)	T	5.96 (152)	3 (76)	2.25 (57)	2.37 (60)	3/4 (19)	3.81 (97)	50	10 (5)
BB-3	2 (50.8)	T	2 (50.8)	T	7.56 (192)	3.87 (98)	2.75 (70)	2.75 (70)	3/4 (19)	4.38 (111)	107	15 (7)
CB-3	2-1/2 (63.5)	T	2 (50.8)	T	7.56 (192)	3.87 (98)	2.75 (70)	2.75 (70)	3/4 (19)	4.38 (111)	107	16 (7)
CC-3	2-1/2 (63.5)	F	2-1/2 (63.5)	F	8.44 (214)	4.75 (121)	4.75 (121)	3.5 (89)	3/4 (19)	5.77 (147)	155	36 (16)
DA-3	3 (76.2)	T	1-1/2 (38.1)	T	7.44 (189)	3.87 (98)	2.75 (70)	2.75 (70)	3/4 (19)	4.38 (111)	68	16 (7)
DB-3	3 (76.2)	T	2 (50.8)	T	7.56 (192)	3.87 (98)	2.75 (70)	2.75 (70)	3/4 (19)	4.38 (111)	107	16 (7)
DC-3	3 (76.2)	F	2-1/2 (63.5)	F	8.75 (222)	5 (127)	5 (127)	3.5 (89)	3/4 (19)	5.77 (147)	155	42 (19)
DD-3	3 (76.2)	F	3 (76.2)	F	9.56 (243)	5.5 (140)	5.5 (140)	3.75 (95)	3/4 (19)	7.02 (178)	238	45 (20)
EC-3	4 (101.6)	F	2-1/2 (63.5)	F	11 (280)	6.5 (165)	6.5 (165)	3.5 (89)	3/4 (19)	5.77 (147)	155	42 (19)
ED-3	4 (101.6)	F	3 (76.2)	F	11 (280)	6.5 (165)	6.5 (165)	3.75 (95)	3/4 (19)	7.93 (201)	238	53 (24)
EE-3	4 (101.6)	F	4 (101.6)	F	11.5 (292)	6.5 (165)	6.5 (165)	4.5 (114)	3/4 (19)	7.86 (200)	372	65 (30)
FE-3	5 (127)	F	4 (101.6)	F	12.5 (318)	7.5 (191)	7.5 (191)	4.5 (114)	3/4 (19)	7.86 (200)	372	80 (36)
FF-3	5 (127)	F	5 (127)	F	13.67 (347)	7.5 (191)	7.5 (191)	5 (127)	3/4 (19)	10.45 (265)	443	92 (42)
GE-3	6 (152.4)	F	4 (101.6)	F	13.5 (343)	8 (203)	8 (203)	4.5 (114)	3/4 (19)	7.86 (200)	372	83 (38)
GF-3	6 (152.4)	F	5 (127)	F	15.67 (398)	8 (203)	8 (203)	5 (127)	3/4 (19)	10.45 (265)	625	97 (44)
GG-3	6 (152.4)	F	6 (152.4)	F	15.82 (402)	8 (203)	8 (203)	5.5 (140)	3/4 (19)	11 (280)	1050	134 (61)
HG-3	8 (203.2)	F	6 (152.4)	F	15.82 (402)	9 (229)	9 (229)	5.5 (140)	3/4 (19)	11 (280)	1050	150 (68)
HH-3	8 (203.2)	F	8 (203.2)	F	19.55 (497)	9 (229)	9 (229)	6.75 (171)	3/4 (19)	12.62 (321)	1640	250 (113)
JH-3	10 (254)	F	8 (203.2)	F	19.55 (497)	10 (254)	11 (279)	6.75 (171)	3/4 (19)	12.62 (321)	1640	290 (132)
JJ-3	10 (254)	F	10 (254)	F	22.8 (579)	11 (279)	11 (279)	8 (230)	3/4 (19)	15.68 (398)	2260	415 (188)

Groove x Flange and Groove x Groove models also available in current design. See submittal B-808.



Xylem Inc.
 8200 N. Austin Avenue
 Morton Grove, Illinois 60053
 Phone: (847) 966-3700
 Fax: (847) 965-8379
 www.xylem.com/bellgossett

Bell & Gossett is a trademark of Xylem Inc. or one of its subsidiaries.
 © 2019 Xylem Inc. B-820H April 2019

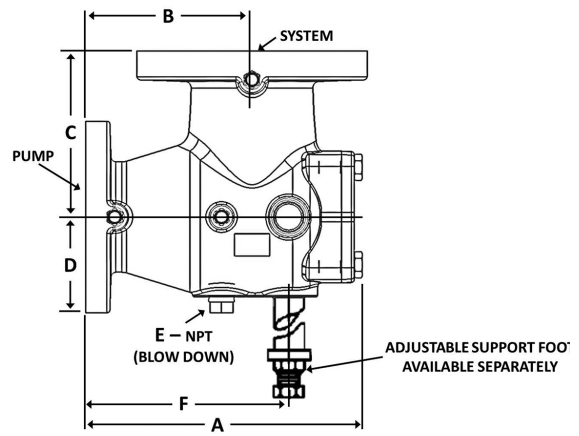

Flange x Flange Models

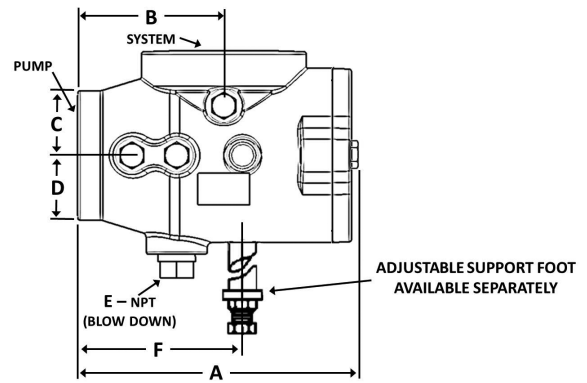

Threaded x Threaded Models