

**MULTI-POSITION, VARIABLE-SPEED  
ECM-BASED, MODULAR BLOWER  
COMFORTNET™ COMPATIBLE**



**Contents**

Air Handler Nomenclature..... 2  
 Heater Kit Nomenclature ..... 2  
 Product Specifications..... 3  
 Airflow Data ..... 3  
 Heat Kit Data..... 4  
 Dimensions ..... 5  
 Wiring Diagram..... 6



**Product Features**

- Variable-speed ECM blower motor
- ComfortNet™ Communicating System compatible
- Advanced configuration of the airflow and tonnage in communicating mode
- Provides constant CFM over a wide range of static pressure conditions independent of duct system
- CFM indicator
- Fault recall of six most recent faults
- Provides adjustable low CFM for efficient fan-only operation
- Improved humidity and comfort control
- Built-in compatibility with multi-stage heat pump and cooling applications
- 3 kW – 21 kW electric heat kits
- Blower section usable as electric heater
- Horizontal or vertical configuration capabilities
- 21" depth for easier attic access
- Foil-faced insulation covers the internal casing to reduce cabinet condensation
- Galvanized, leather grain-embossed finish
- Cabinet air leakage less than 2% at 1.0 inch H<sub>2</sub>O when tested in accordance with ASHRE standard 193
- Cabinet air leakage less than 1.4% at 0.5 inch H<sub>2</sub>O when tested in accordance with ASHRE standard 193
- AHRI certified; ETL listed



Intertek

COMPANY WITH  
QUALITY SYSTEM  
CERTIFIED BY DNV GL  
■ ISO 9001 ■

COMPANY WITH  
ENVIRONMENTAL SYSTEM  
CERTIFIED BY DNV GL  
■ ISO 14001 ■

\* Complete warranty details available from your local dealer or at [www.amana-hac.com](http://www.amana-hac.com). To receive the 10-Year Parts Limited Warranty, online registration must be completed within 60 days of installation. Online registration is not required in California or Québec.

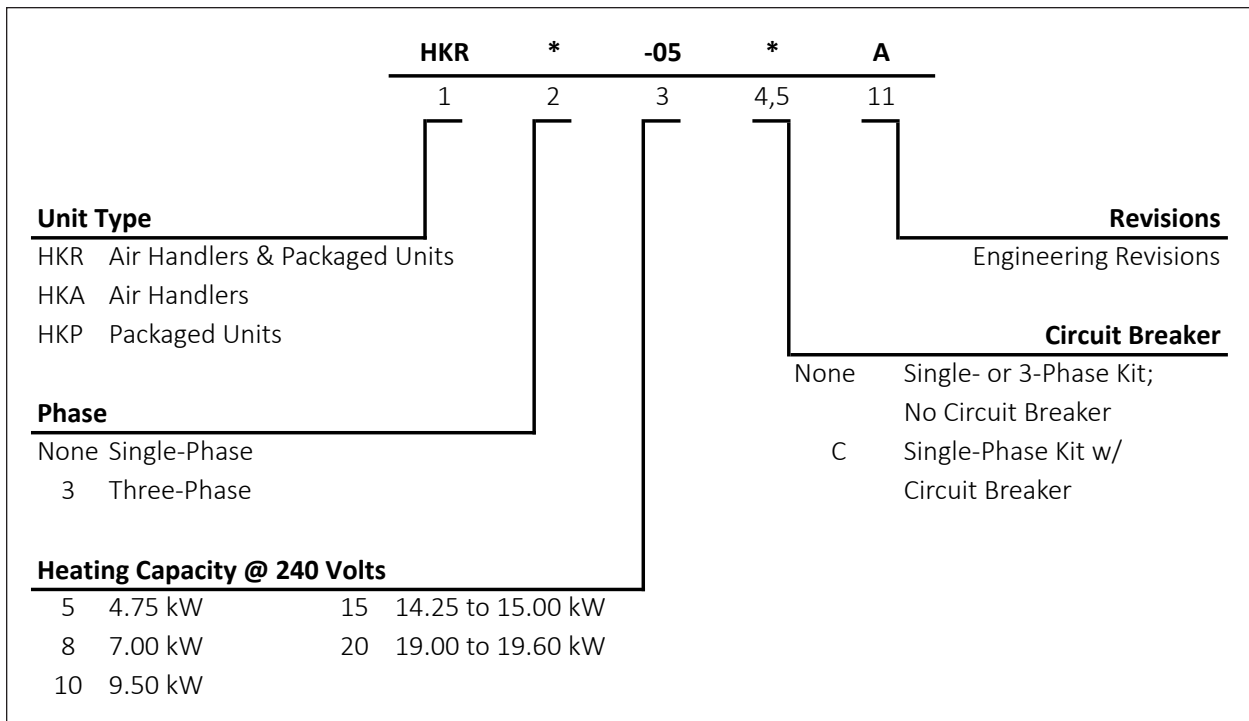
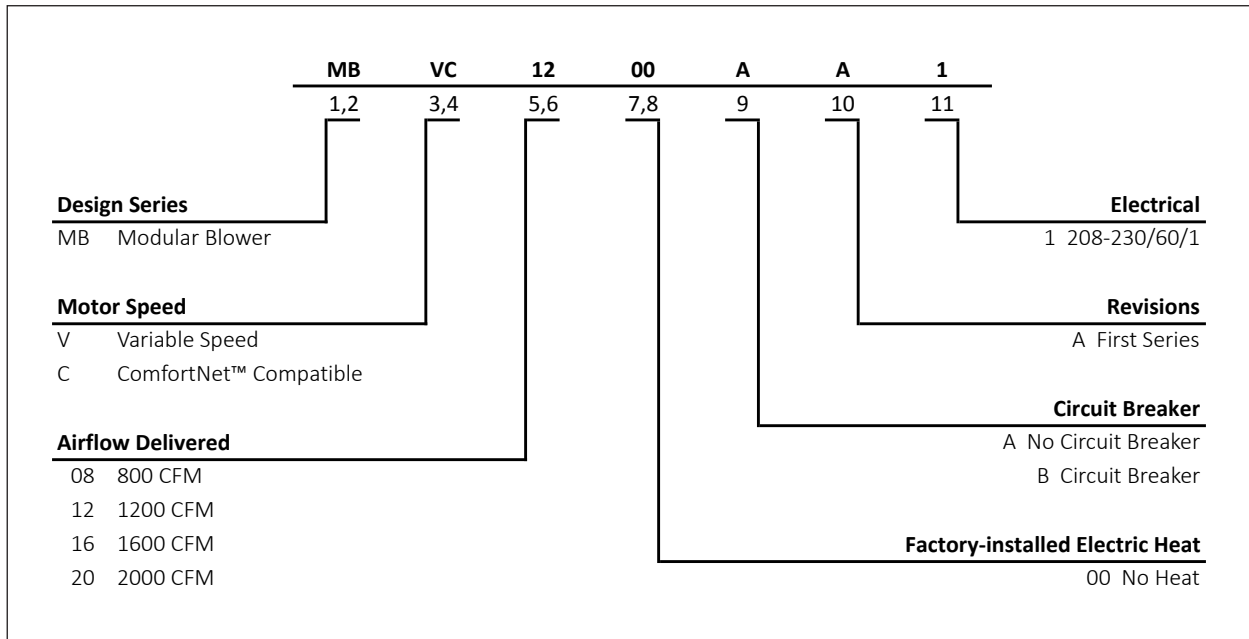

MODEL	MBVC1200AA-1	MBVC1600AA-1	MBVC2000AA-1
<b>BLOWER</b>			
Diameter	10"	10"	11"
Width	8"	8"	10"
<b>ELECTRICAL DATA</b>			
Voltage	208 / 230	208 / 230	208 / 230
Min Circuit Ampacity	4.9	6.5	6.5
Max. Overcurrent Device (Amps)	15	15	15
<b>Blower Motor</b>			
Horsepower (HP)	½	¾	¾
<b>SHIP WEIGHT (LBS.)</b>	67	80	86

- Minimum Circuit Ampacity (MCA) and Maximum Overcurrent Protection (MOP) for blower without supplemental heat installed. Refer to unit nameplate for these specifications with approved accessory heaters installed.
- Condensate management kits are available for units installed in high temperature and high humidity areas. Kit number MBK0002 has been developed to resolve condensate issues in the field for MBVCs and is available from the Service Parts Department. Refer to IO-849 for installation instructions.

MODEL	SPEED TAP	SPEED	0.1	0.2	0.3	0.4	0.5	0.6	0.7	0.8	0.9
MBVC1200A*	A	Low	420	415	400	400	395	390	390	390	380
	B	Low	550	545	540	540	535	530	530	525	520
	C	Low	680	675	670	665	660	655	655	650	640
	D	Low	810	805	800	800	800	795	790	785	785
	A	High	615	605	600	600	595	590	590	585	580
	B	High	805	805	800	800	800	795	790	785	780
	C	High	1010	1005	1000	1000	995	995	990	985	975
	D	High	1210	1205	1200	1200	1200	1195	1195	1190	1180
MBVC1600A*	A	Low	690	680	670	665	660	655	625	595	575
	B	Low	850	830	800	795	790	785	775	750	725
	C	Low	980	970	940	935	930	910	890	865	860
	D	Low	1110	1085	1070	1055	1045	1025	1000	990	975
	A	High	1045	1015	1000	990	975	950	935	920	900
	B	High	1245	1215	1200	1180	1175	1165	1150	1130	1115
	C	High	1415	1410	1400	1365	1360	1350	1340	1330	1320
	D	High	1605	1600	1600	1540	1530	1520	1510	1500	1490
MBVC2000A*	A	Low	835	815	800	800	795	795	790	775	750
	B	Low	1075	1070	1070	1065	1050	1045	1045	1040	1035
	C	Low	1210	1205	1200	1200	1195	1190	1190	1185	1175
	D	Low	1345	1340	1340	1320	1320	1315	1315	1305	1305
	A	High	1210	1205	1200	1195	1150	1150	1145	1135	1115
	B	High	1610	1605	1600	1540	1535	1535	1530	1520	1510
	C	High	1830	1805	1800	1785	1760	1760	1755	1750	1715
	D	High	2020	2010	2000	1995	1995	1970	1970	1965	1955

**COOLING AND HEAT PUMP AIRFLOW**

S1	S2	SPEED TAP	MBVC1200 AIRFLOW (SCFM)	MBVC1600 AIRFLOW (SCFM)	MBVC2000 AIRFLOW (SCFM)
off	off	A	600	1000	1200
on	off	B	800	1200	1600
off	on	C	1000	1400	1800
on	on	D	1200	1600	2000

**HEAT KIT AIRFLOW**

COOLING / HP / AUX TRIM			COOLING PROFILE		
S3	S4	Trim Value	S5	S6	
off	off	0	off	off	A
on	off	10%	on	off	B
off	on	-10%	off	on	C
on	on	0	on	on	D

**NOTES**

- The chart is for information only. For satisfactory operation, external static pressure must not exceed value shown on rating plate.
- Use the CFM adjustment factors of .98 for horizontal left, .95 for horizontal right & .96 for downflow orientations.

MODELS	CIRCUIT 1			CIRCUIT 2			SINGLE-POINT KIT	
	HEATER AMPS	MCA <sup>1</sup>	MOP <sup>2</sup>	HEATER AMPS	MCA <sup>1</sup>	MOP <sup>2</sup>	MCA <sup>1</sup>	MOP <sup>2</sup>
<b>MBVC1200AA-1A*</b>	0 / 0	4.9 / 4.9	15 / 15	---	---	---	---	---
HKR-03*	10.8 / 12.5	18 / 20.5	20 / 25	---	---	---	---	---
HKR-05* / 05C*	17.2 / 19.8	26 / 29.6	30 / 30	---	---	---	---	---
HKR-06*	21.7 / 25.0	32 / 36.1	35 / 40	---	---	---	---	---
HKR-08* / -08C*	25.3 / 29.2	36.5 / 41	40 / 45	---	---	---	---	---
HKR-10* / -10C*	34.3 / 39.6	47.8 / 54	50 / 60	---	---	---	---	---
HKA-15C*	34.3 / 39.6	47.8 / 54	50 / 60	17.2 / 19.8	21.4 / 24.7	25 / 25	69/79	70 / 80
<b>MBVC1600AA-1A*</b>	0 / 0	6.5 / 6.5	15 / 15	---	---	---	---	---
HKR-03*	10.8 / 12.5	20.1 / 22	25 / 25	---	---	---	---	---
HKR-05* / 05C*	17.2 / 19.8	27.9 / 31	30 / 35	---	---	---	---	---
HKR-06*	21.7 / 25.0	34 / 37.8	35 / 40	---	---	---	---	---
HKR-08* / -08C*	25.3 / 29.2	38.1 / 43	40 / 45	---	---	---	---	---
HKR-10* / -10C*	34.3 / 39.6	49.4 / 56	50 / 60	---	---	---	---	---
HKA-15C*	34.3 / 39.6	49.4 / 56	50 / 60	17.2 / 19.8	21.4 / 24.7	25 / 25	71/81	80 / 90
<b>MBVC2000AA-1A*</b>	0 / 0	6.5 / 6.5	15 / 15	---	---	---	---	---
HKR-03*	10.8 / 12.5	20.1 / 22	25 / 25	---	---	---	---	---
HKR-05* / 05C*	17.2 / 19.8	27.9 / 31	30 / 35	---	---	---	---	---
HKR-06*	21.7 / 25.0	34 / 37.8	35 / 40	---	---	---	---	---
HKR-08* / -08C*	25.3 / 29.2	38.1 / 43	40 / 45	---	---	---	---	---
HKR-10* / -10C*	34.3 / 39.6	49.4 / 56	50 / 60	---	---	---	---	---
HKA-15C*	34.3 / 39.6	49.4 / 56	50 / 60	17.2 / 19.8	21.4 / 24.7	25 / 25	70/80	70 / 80
HKA-20C*	34.3 / 39.6	49.4 / 56	50 / 60	34.3 / 39.6	42.9 / 49.5	45 / 50	92/105	100 / 110

All ampacities noted above include air handler motor amps

Circuit 1: Single-phase for Air Handlers / Circuit 2: Three-phase for HKR3 Heater Kits

<sup>1</sup> Minimum Circuit Ampacity (Heater Amps + Motor Amps) X 1.25

<sup>2</sup> Maximum Overcurrent Protection = 2.25 X Motor Amps + Heater Amps

\* Revision level that may or may not be designated

C = Circuit Breaker Option

--- indicates Not Required

- Only applicable when HKA kits are included in table  
HKA meets the new UL1995 requirements for 15 and 20KW heaters
- MBVC and MBR models

### HEATING KW CORRECTION FACTOR

SUPPLY VOLTAGE	240	230	220	210	208
CORRECTION FACTOR	1.00	0.92	0.84	0.77	0.75

Multiply the 240-volt heating capacity by correction factors.

SIDE AND FRONT VIEWS

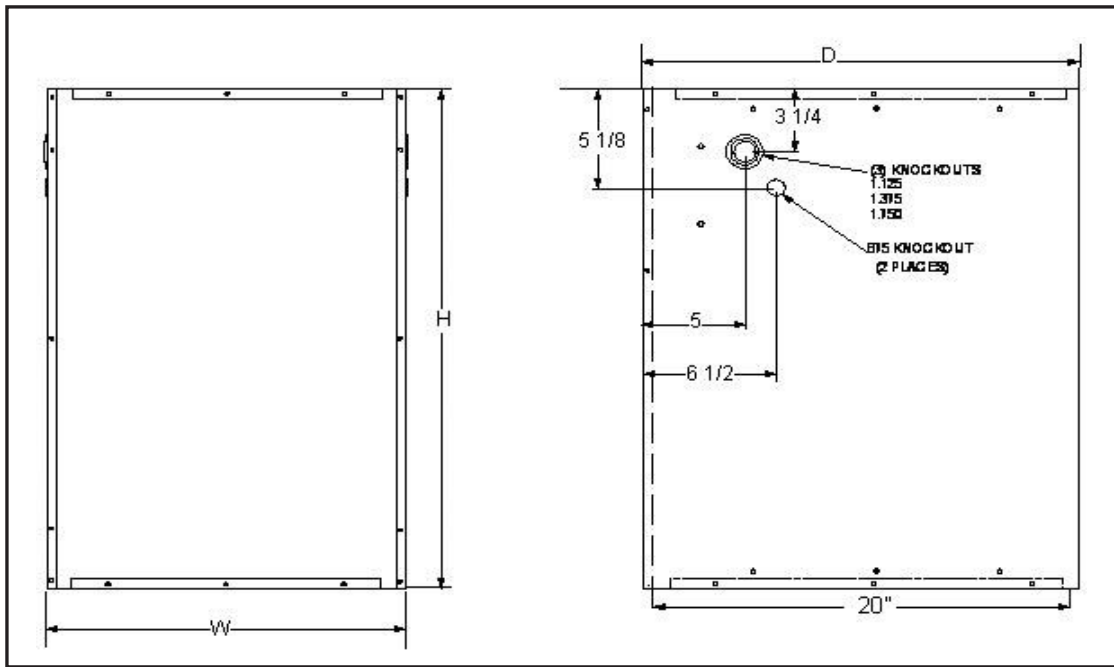

MODEL	DIMENSIONS		
	WIDTH	DEPTH	HEIGHT
MBVC1200AA-1	17½"	21"	26"
MBVC1600AA-1	21"	21"	30"
MBVC2000AA-1	24½"	21"	30"

TOP VIEW

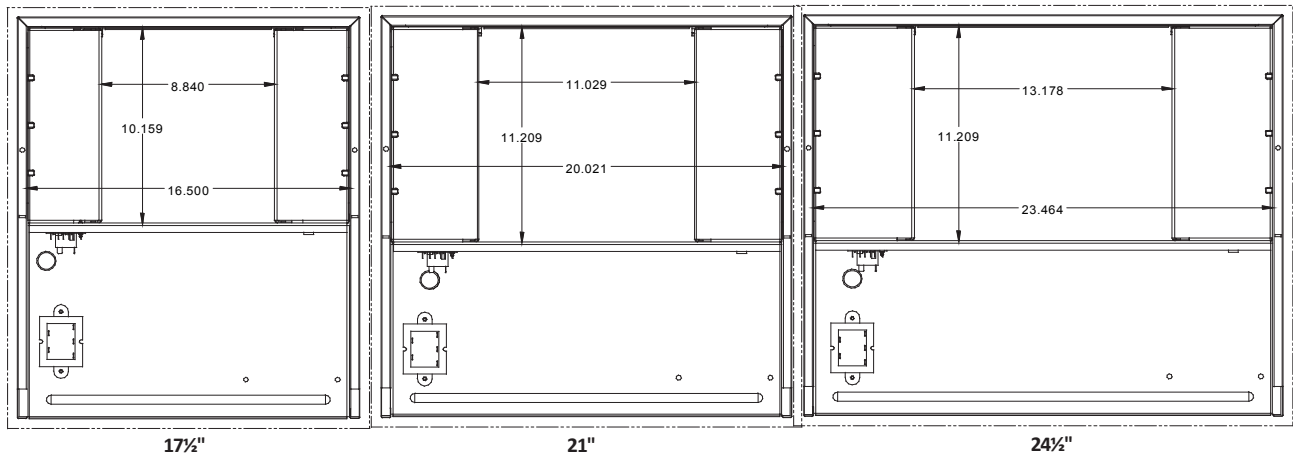

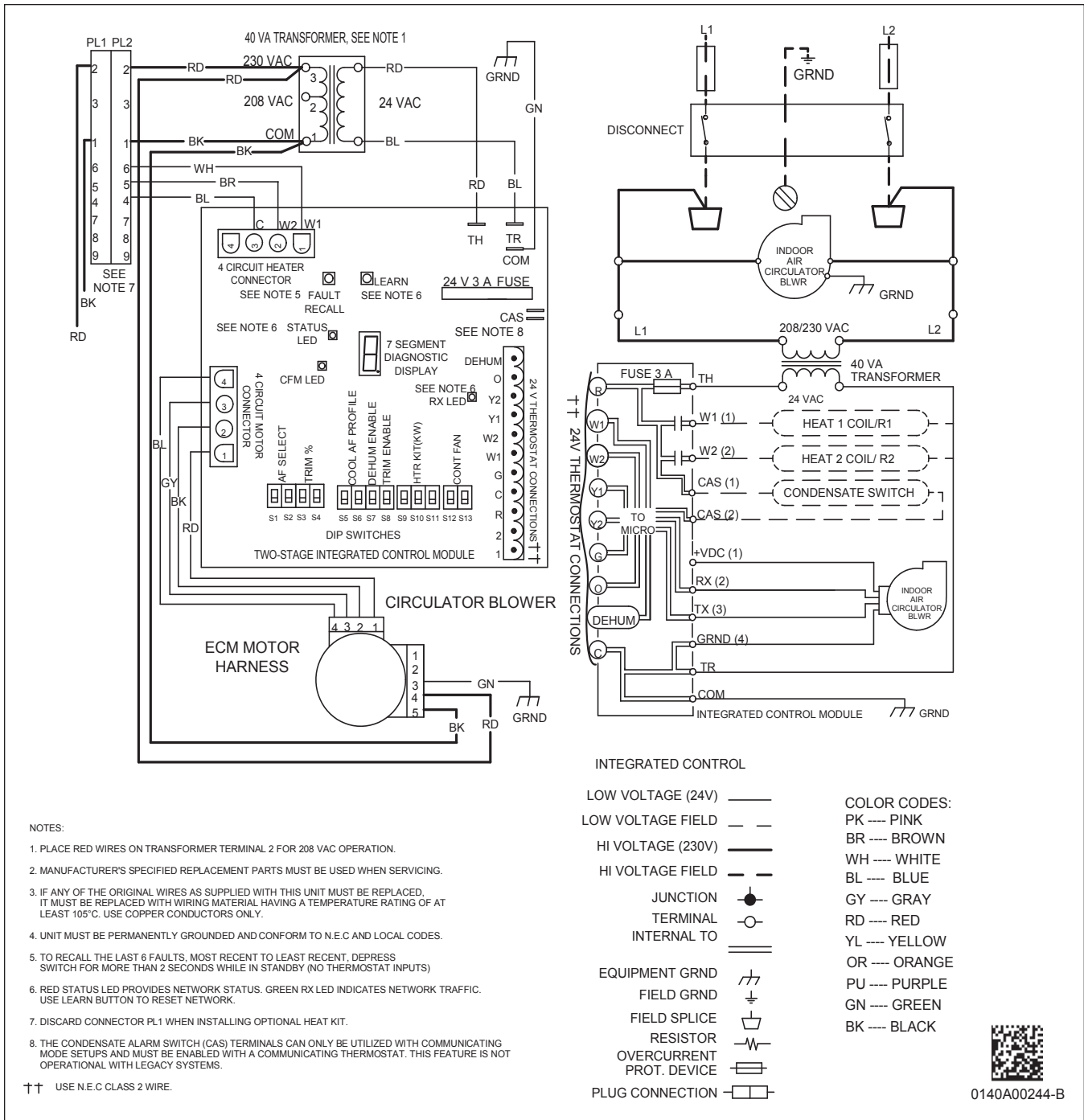

**⚠ WARNING** **High Voltage:** Disconnect all power before servicing or installing this unit. Multiple power sources may be present. Failure to do so may cause property damage, personal injury, or death. **⚡**

Wiring is subject to change. Always refer to the wiring diagram on the unit for the most up-to-date wiring.

WIRING DIAGRAM – FIVE-ELEMENT HEATER KIT

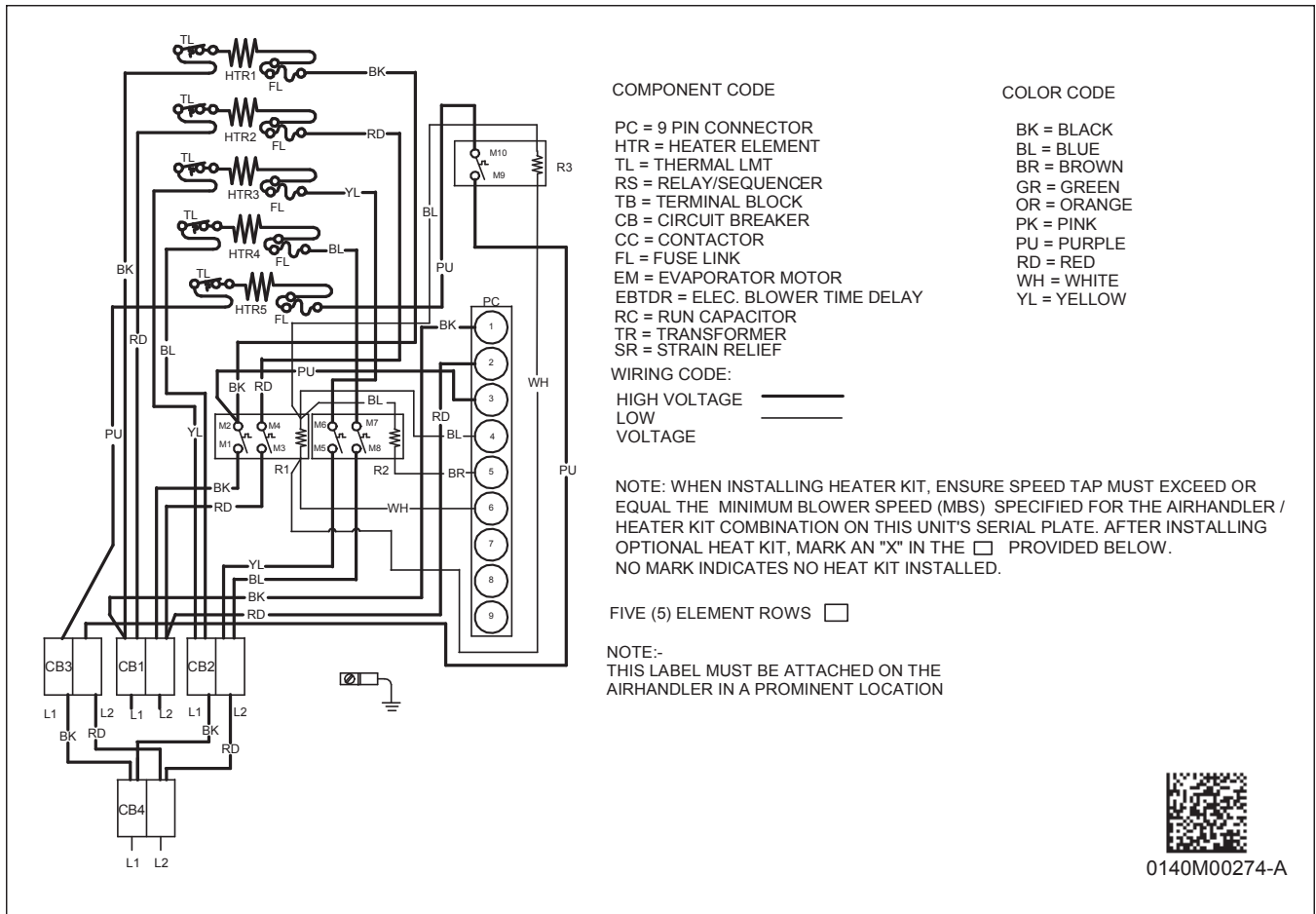

**⚠ WARNING** **High Voltage:** Disconnect all power before servicing or installing this unit. Multiple power sources may be present. Failure to do so may cause property damage, personal injury, or death. ⚡

Wiring is subject to change. Always refer to the wiring diagram on the unit for the most up-to-date wiring.