

Pipe Covering Protection Saddle For Nominal Thickness of Covering Shown

- Fig. 160: 1" Fig. 161: 1½" Fig. 162: 2"
- Fig. 163: 2½" Fig. 164: 3" Fig. 165: 4"
- Fig. 165A: 4" (Alloy) Fig. 166A: 5½" (Alloy)

Size Range: ¾" through 36"

Material:

- Figs. 160, 161, 162, 163, 164, and 165 are curved carbon steel plate.
- Figs. 165A and 166A are alloy steel manufactured from ASTM A 387 Grade 22 Chrome Molybdenum steel plate.
- Figs. 165A and 166A have a welded-in center plate in all sizes.
- All other saddles have a welded-in center plate for pipe sizes 12" and larger.
- All saddles are 12" long with side edges turned up.

Finish: Plain

Service: Designed for use on insulated high temperature systems where heat losses are to be kept to a minimum and to protect insulation against damage.

Maximum Temperature: 650° F carbon steel, 950° F alloy steel.

Approvals: Complies with Federal Specification A-A-1192A (Type 39A & 39B), WW-H-171-E (Type 40A & 40B), ANSI/MSS SP-69 and MSS SP-58 (Type 39A & 39B).

Features: Permits finished, weather tight covering at all points of pipe support.

Ordering: Specify pipe size, figure number and name. Data for 42" size available on request.

Installation: It is recommended that saddle be welded to the pipe.

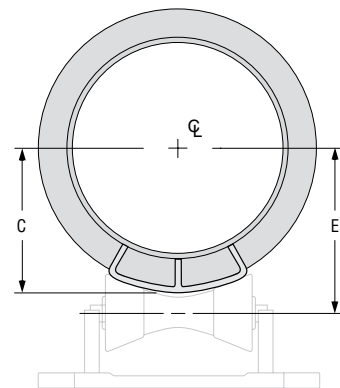
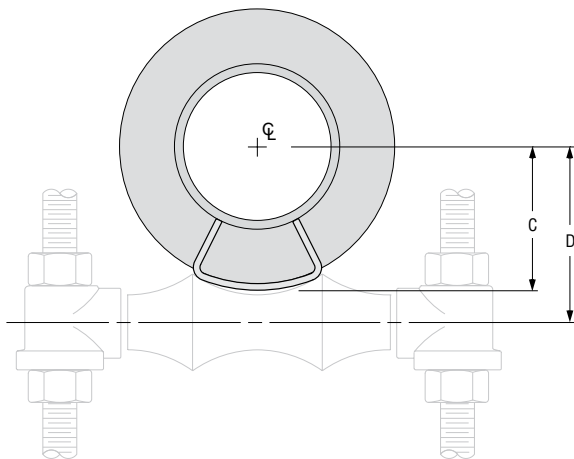

Continued on Following Page.

PROJECT INFORMATION	APPROVAL STAMP
Project:	<input type="checkbox"/> Approved
Address:	<input type="checkbox"/> Approved as noted
Contractor:	<input type="checkbox"/> Not approved
Engineer:	Remarks:
Submittal Date:	
Notes 1:	
Notes 2:	

Fig. 160 to Fig 166A Pipe Covering Protection Saddle (cont.)

FIG. 160, 161, 162, 163, 164, 165, 165A, 166A: DIMENSIONS (IN) • LOADS (LBS) • WEIGHT (LBS)											
Pipe Size	Fig. No.	Max Load ■	Weight	Size of Pipe Roll			Center Line of Pipe to Outside of Saddle C	Center Line of Pipe to Center Line of Roll			
				Figs. 171, 175, 177	Fig. 181	Figs. 271, 274, 277		D		E	
								Figs. 171, 175, 177	Fig. 181	Figs. 271, 274, 277	Figs. 271, 274, 277
¾	160•	1,200	1.4	2	2½	2-3½	1⅝	2¼/16	2⅞	2¼	
	161•		2.1	3	3½		2¾/16	2¾	2¾	2⅞	
	162•		2.8	4	5		2¹¹/16	3⅝/16	3⅝/16	3⅝	
1	160•	1,200	1.4	2½	3	2-3½	1¹³/16	2⅝/16	2¼	2⅞/16	
	161•		2.1	3	4		2⁵/16	2⅞	2⅞	3	
	162•		2.8	4	5		2⅞	3½	3½	3½	
1¼	160	1,200	1.4	2½	3	2-3½	1¹⁵/16	2½	2⅞/16	2⁹/16	
	161•		2.1	3½	5		2⁹/16	3¼/16	3¼/16	3³/16	
	162•		2.8	4	5		3	3⅝	3⅝	3¹¹/16	
	163•		3.6	5	6	4-6	3¾	4¾	4¾	4¾	
1½	160	1,200	1.5	3	3½	2-3½	2⅞	2⅝	2⅝	2¹¹/16	
	161•		2.1	3½	5		2⅝	3¼	3¼	3⅝/16	
	162•		3.2	5	6		3⅝/16	4	4	3⅞	
	163•		3.6	6	8	4-6	3⅞	4½	4⅝	4½	
2	160	1,200	1.7	3½	4	2-3½	2⅞	3	2¹⁵/16	3¼/16	
	161•		2.3	4	5		2⅞	3½	3½	3⁹/16	
	162•		3.2	5	6		3⁹/16	4¼	4¼	4³/16	
	163•		3.6	6	8	4-6	4¼/16	4¾	4¹³/16	4¾	
	164•		4.5	8	8		4⁹/16	5⅜	5⅜	5¼	
2½	160	1,200	1.7	3½	5	2-3½	2¹¹/16	3¼	3¼	3⁵/16	
	161		2.8	5	6		3⁵/16	4	4	3¹⁵/16	
	162		3.2	6	8	4-6	3⅞	4½	4⅝	4½	
	163		4.1	8	10		4¼	5⅞	5⅞	5	
	164		4.5	8	10		4⅞	5⅝	5¾	5½	
3	160	1,200	1.9	4	5	2-3½	2¹⁵/16	3½	3½	3⁹/16	
	161		2.8	5	6		3⅝	4⅝/16	4⅝/16	4¼	
	162		3.6	6	8	4-6	4⅞	4¹³/16	4¹³/16	4¹¹/16	
	163		4.1	8	10		4¹¹/16	5⅞/16	5⅞/16	5⁵/16	
	164		4.9	8	10		8-10	5¼/16	6	6	6¼/16
3½	160	1,200	2.3	5	6	4-6	3⁵/16	4	4	3¹⁵/16	
	161		3.2	6	8		3¹¹/16	4⁹/16	4⁹/16	4½	
	162		3.6	8	10		4⁵/16	5⅞	5⅞	5	
	163		4.5	8	10	8-10	4¹¹/16	5⁵/8	5⁵/8	5¹¹/16	
	164		4.9	10	10		5⅝	6⁵/16	6⁵/16	6⅝	
4	160	1,200	2.3	5	6	4-6	3⁹/16	4¼	4¼	4³/16	
	161		3.2	6	8		4¼/16	4⅞	4⅞	4¾	
	162		3.6	8	10		4⁹/16	5⅜	5⅜	5¼	
	163		4.5	8	10	8-10	5	5¹⁵/16	5¹⁵/16	6	
	164		4.9	10	12		5⅝	6⁹/16	6⁹/16	6⅝	
	165		6.1	10	12	12-14	6½	7⅝	7⅝	7⁹/16	
	165A	11.6	14	16	8⅞		9⅝	9½	9⅝/16		
166A	15.7	14	16								

- Maximum recommended loads are applicable only when saddle is used on a flat bearing surface or roller hangers and tack welded to pipe. When saddle is used with a pipe roll, the maximum load for the assembly is the smaller of the two loads.
- Saddles may require notching when used with a U-bolt.

Continued on Following Page.

Fig. 160 to Fig 166A Pipe Covering Protection Saddle (cont.)

FIG. 160, 161, 162, 163, 164, 165, 165A, 166A: DIMENSIONS (IN) • LOADS (LBS) • WEIGHT (LBS)													
Pipe Size	Fig. No.	Max Load ■	Weight	Size of Pipe Roll			Center Line of Pipe to Outside of Saddle C	Center Line of Pipe to Center Line of Roll					
				Figs. 171, 175, 177	Fig. 181	Figs. 271, 274, 277		D		E			
								Figs. 171, 175, 177	Fig. 181	Figs. 271, 274, 277			
5	160	1,200	2.3	6	8	4-6	4 ¹ / ₈	4 ¹³ / ₁₆	4 ¹³ / ₁₆	4 ³ / ₄			
	161		3.2	8			10	8-10	4 ¹¹ / ₁₆	5 ¹ / ₂	5 ¹ / ₂	5 ³ / ₈	
	162		3.6		10	12			12-14	5 ³ / ₁₆	6	6 ¹ / ₁₆	6 ¹ / ₈
	163		4.5	12			14	16		5 ⁵ / ₈	6 ⁹ / ₁₆	6 ⁹ / ₁₆	6 ⁵ / ₈
	164		4.9		16	18			20	6 ³ / ₁₆	7 ¹ / ₈	7 ¹ / ₄	7 ¹ / ₄
	165	6.1	7,200	16			18	20		7 ¹ / ₈	8 ³ / ₁₆	8 ³ / ₈	8 ³ / ₁₆
	165A	11.6			10 ¹ / ₁₆	10 ¹ / ₁₆			9 ⁷ / ₈	8 ¹ / ₈	8 ¹ / ₈	8 ¹ / ₈	
	166A	15.7								8 ¹¹ / ₁₆	9 ⁷ / ₈	9 ⁷ / ₈	9 ⁷ / ₈
6	160	1,800	3.8	8	8	4-6	4 ¹ / ₂	5 ³ / ₈	5 ³ / ₈	5 ¹ / ₄			
	161		4.4	10	12	8-10	5 ¹ / ₁₆	5 ⁷ / ₈	5 ¹¹ / ₁₆	6			
	162		5.7				12	16	12-14	5 ¹ / ₂	6 ⁷ / ₁₆	6 ⁷ / ₁₆	6 ¹ / ₂
	163		6.5	14	16	16-20				6 ³ / ₁₆	7 ¹ / ₈	7 ³ / ₁₆	7 ¹ / ₄
	164		7.7				16	18	20	6 ⁹ / ₁₆	7 ⁵ / ₈	7 ⁵ / ₈	7 ⁵ / ₈
	165	10.2	7,200	18	20	22				7 ⁹ / ₁₆	9	9	8 ³ / ₄
	165A	12.9					10 ¹ / ₁₆	10 ¹ / ₁₆	9 ¹ / ₈	8 ¹³ / ₁₆	7 ⁵ / ₈	9 ¹ / ₈	9 ¹ / ₈
	166A	16.3									9 ¹ / ₈	10 ⁵ / ₈	10 ⁹ / ₁₆
8	161	1,800	5.8	10	12	8-10	6	7 ¹ / ₁₆	7 ¹ / ₁₆	7 ¹ / ₁₆			
	162		6.3	12	14		12-14	6 ¹ / ₂	7 ⁹ / ₁₆	7 ⁹ / ₁₆	7 ⁹ / ₁₆		
	163		7.2			14		16	16-20	7 ¹ / ₄	8 ⁵ / ₁₆	8 ¹ / ₂	8 ⁵ / ₁₆
	164		7.7	16	18		20			7 ¹¹ / ₁₆	9	9	8 ³ / ₄
	165		10.2			18		20	22	8 ¹¹ / ₁₆	10 ¹ / ₈	10 ¹ / ₈	9 ⁷ / ₈
	165A	16.9	10 ¹ / ₄	11 ⁷ / ₈	11 ¹³ / ₁₆		11 ⁵ / ₈			10 ¹ / ₁₆	11 ¹³ / ₁₆	11 ⁵ / ₈	
	166A	22.6				10 ¹ / ₄		11 ⁷ / ₈	11 ¹³ / ₁₆	11 ⁵ / ₈			
10	161	1,800	5.8	12	14	8-10	7 ¹ / ₄	8 ⁵ / ₁₆	8 ¹ / ₂	8 ⁵ / ₁₆			
	162		7.7	14	16		12-14	7 ⁵ / ₈	9 ¹ / ₁₆	9	8 ¹³ / ₁₆		
	163		8.2			16		18	16-20	8 ¹ / ₈	9 ⁹ / ₁₆	9 ⁹ / ₁₆	9 ⁵ / ₁₆
	164		8.8	18	20		22			8 ¹¹ / ₁₆	10 ¹ / ₈	10 ¹ / ₁₆	10
	165		10.8			10 ³ / ₄		11 ¹ / ₄	11 ¹ / ₄	9 ³ / ₄	11 ¹ / ₄	11 ¹ / ₄	11 ¹ / ₈
	165A	18.9	9 ¹¹ / ₁₆	11 ⁵ / ₁₆	11 ⁵ / ₁₆		9 ¹¹ / ₁₆			11 ⁵ / ₁₆	11 ⁵ / ₁₆	11 ⁵ / ₁₆	
	166A	24.3				11 ¹ / ₈	12 ¹⁵ / ₁₆	12 ¹⁵ / ₁₆	12 ¹⁵ / ₁₆				
12	161	5,000	7.8	14	16	12-14	8 ¹ / ₁₆	9 ¹ / ₂	9 ¹ / ₂	9 ¹ / ₄			
	162		9.9	16	18		16-20	8 ⁵ / ₈	10 ³ / ₁₆	10 ¹ / ₁₆	10		
	163		10.5			18		20	22	9 ¹ / ₈	10 ¹¹ / ₁₆	10 ⁹ / ₁₆	10 ¹ / ₂
	164		11.4	20	24		26			9 ⁵ / ₈	11 ¹ / ₈	11 ¹ / ₈	11
	165		14.0			22		24	26	10 ¹³ / ₁₆	12 ³ / ₈	12 ³ / ₈	12 ³ / ₁₆
	165A	28.0	11	12 ¹ / ₂	12 ¹ / ₂		11			12 ¹ / ₂	12 ¹ / ₂	12 ³ / ₈	
	166A	35.5				12 ⁵ / ₁₆	14 ¹ / ₄	14 ¹ / ₄	13 ¹ / ₁₆				
	14	161	5,000	7.8	16	18	12-14	8 ³ / ₄	10 ³ / ₁₆	10 ¹ / ₈	10 ¹ / ₁₆		
162		9.9		18	20	16-20		9 ⁵ / ₁₆	10 ⁷ / ₈	10 ¹³ / ₁₆	10 ¹¹ / ₁₆		
163		10.5					20	24	26	9 ⁷ / ₈	11 ⁵ / ₁₆	11 ³ / ₈	11 ³ / ₁₆
164		11.4		22	24	26				10 ⁵ / ₁₆	11 ³ / ₄	11 ³ / ₄	11 ⁵ / ₈
165		14.0					11 ⁵ / ₁₆	12 ⁷ / ₈	12 ⁷ / ₈	11 ⁵ / ₁₆	12 ⁷ / ₈	12 ⁷ / ₈	12 ⁵ / ₈
165A		27.6	11 ⁹ / ₁₆	13 ¹ / ₁₆	13 ¹ / ₁₆	11 ⁹ / ₁₆				13 ¹ / ₁₆	13 ¹ / ₁₆	12 ⁷ / ₈	
166A		35.5				12 ⁷ / ₈	14 ³ / ₄	14 ³ / ₄	14 ¹ / ₄				

- Maximum recommended loads are applicable only when saddle is used on a flat bearing surface or roller hangers and tack welded to pipe. When saddle is used with a pipe roll, the maximum load for the assembly is the smaller of the two loads.
- Saddles may require notching when used with a U-bolt.

Continued on Following Page.

Fig. 160 to Fig 166A Pipe Covering Protection Saddle (cont.)

FIG. 160, 161, 162, 163, 164, 165, 165A, 166A: DIMENSIONS (IN) • LOADS (LBS) • WEIGHT (LBS)											
Pipe Size	Fig. No.	Max Load ■	Weight	Size of Pipe Roll			Center Line of Pipe to Outside of Saddle C	Center Line of Pipe to Center Line of Roll			
				Figs. 171, 175, 177	Figs. 174, 181	Figs. 271, 274, 277		D		E	
								Figs. 171, 175, 177	Fig. 181	Figs. 271, 274, 277	
16	161	5,000	8.4	18	20	16-20	9 ¹³ / ₁₆	11 ¹ / ₄	11 ¹ / ₄	11 ¹ / ₈	
	162		10.4				10 ³ / ₁₆	11 ³ / ₁₆	11 ³ / ₄	11 ⁹ / ₁₆	
	163	7,200	11.1	20	—	22-24	10 ¹³ / ₁₆	12 ⁵ / ₁₆	—	12 ³ / ₁₆	
	164		13.3	24	—		11 ¹ / ₁₆	12 ⁷ / ₈	—	12 ⁷ / ₁₆	
	165		15.3		—		12 ³ / ₁₆	14 ¹ / ₈	—	13 ⁵ / ₈	
	165A	11,140	30.1	—	—	26-30	12 ⁷ / ₁₆	14 ⁵ / ₁₆	—	13 ³ / ₈	
	166A		40.0	30	—		13 ¹³ / ₁₆	16 ⁵ / ₈	—	15 ⁵ / ₈	
18	161	5,000	9.1	20	—	16-20	10 ¹³ / ₁₆	12 ⁵ / ₁₆	—	12 ³ / ₁₆	
	162	7,200	10.4				—	22-24	11 ⁵ / ₁₆	12 ⁷ / ₈	—
	163		12.4	—	11 ⁵ / ₈	13 ⁹ / ₁₆	—		13 ¹ / ₁₆		
	164		13.3	24	—	12 ¹ / ₄	14 ³ / ₁₆		—	13 ⁵ / ₈	
	165	15.3	—		13 ⁵ / ₁₆	15 ¹ / ₄	—	14 ³ / ₄			
	165A	13,370	40.3	—	—	26-30	13 ³ / ₄	15 ¹¹ / ₁₆	—	15 ¹ / ₈	
	166A		52.1	30	—		14 ⁷ / ₈	17 ⁵ / ₈	—	16 ⁵ / ₈	
20	161	7,200	10.4	24	—	22-24	11 ⁵ / ₈	13 ⁹ / ₁₆	—	13 ¹ / ₁₆	
	162		11.6				—	12 ¹ / ₄	14 ¹ / ₈	—	13 ⁵ / ₈
	163		12.4				—	12 ³ / ₄	14 ¹¹ / ₁₆	—	14 ³ / ₁₆
	164	13.4	13,370	30	—	26-30	13 ⁵ / ₁₆	15 ¹ / ₄	—	14 ³ / ₄	
	165	22.8					—	14 ¹ / ₈	17	—	15 ⁷ / ₈
	165A	44.8					—	14 ³ / ₈	17 ³ / ₁₆	—	16 ¹ / ₈
	166A	52.1					—	16 ¹ / ₈	18 ¹⁵ / ₁₆	—	17 ⁷ / ₈
24	161	7,200	12.3	30	—	26-30	13 ¹ / ₂	16 ⁵ / ₁₆	—	15 ¹ / ₄	
	162		13.4				—	14	16 ⁷ / ₈	—	15 ³ / ₄
	163		14.3				—	14 ⁵ / ₈	17 ¹ / ₂	—	16 ⁷ / ₁₆
	164	20.3	13,370	—	—	26-30	15 ¹ / ₄	18 ¹ / ₁₆	—	17	
	165	23.1					—	16 ⁷ / ₁₆	19 ¹ / ₄	—	18 ³ / ₁₆
	165A	45.4					—	16 ¹¹ / ₁₆	19 ¹ / ₂	—	18 ⁷ / ₁₆
	166A	52.1					—	18	—	—	19 ³ / ₄
30	161	7,200	13.3	—	—	36-42	16 ¹⁵ / ₁₆	—	—	18 ⁷ / ₈	
	162		14.0				—	—	17 ¹ / ₂	—	19 ³ / ₈
	163		20.0				—	—	18 ¹ / ₁₆	—	19 ¹⁵ / ₁₆
	164	21.4	13,370	—	—	36-42	18 ⁵ / ₈	—	—	20 ¹ / ₂	
	165	24.0					—	—	19 ¹ / ₁₆	—	21 ¹ / ₂
	165A	47.9					—	—	19 ¹⁵ / ₁₆	—	21 ³ / ₄
	166A	55.6					—	—	21 ¹ / ₂	—	23 ³ / ₈
36	161	7,200	18.0	—	—	36-42	20 ¹ / ₄	—	—	22 ¹ / ₈	
	162		18.9				—	—	20 ¹⁵ / ₁₆	—	22 ⁵ / ₈
	163		20.2				—	—	21 ⁵ / ₁₆	—	23 ³ / ₁₆
	164	21.6	13,370	—	—	36-42	21 ⁷ / ₈	—	—	23 ¹ / ₁₆	
	165	24.1					—	—	22 ⁷ / ₈	—	24 ¹ / ₁₆
	165A	48.3					—	—	23 ¹ / ₈	—	25
	166A	55.8					—	—	24 ⁵ / ₈	—	26 ¹ / ₂

- Maximum recommended loads are applicable only when saddle is used on a flat bearing surface or roller hangers and tack welded to pipe. When saddle is used with a pipe roll, the maximum load for the assembly is the smaller of the two loads.
- Saddles may require notching when used with a U-bolt.