

ANCHOR FLUID POWER**Mailing Address:**

5553 Murray Road,
Cincinnati, OH 45227

Phone: 866.FLANGES

Fax: 513.527.4449

E-Mail: sales@anchorfluidpower.com

Website: www.anchorfluidpow.wpengine.com



AN ANCHOR FLANGE COMPANY

Item # 12SFX0, 1.140 Inch (in) Dimension A 3/8-16 x 1.50 Mounting Hardware - HHCS SAE J518 Split Carbon Steel Flange

Anchor part # includes: (1) split flange half only.

Kit part # includes: (2) split flange halves, (4) hex head screws with flat washers, (1)

Buna N O-Ring Split flange halves are silver trivalent plated.

List Price

—

Quote

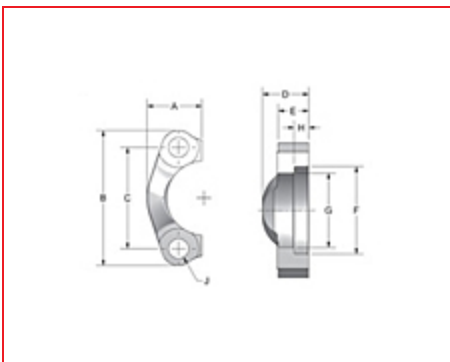

Specifications

—

Dimension Drawing

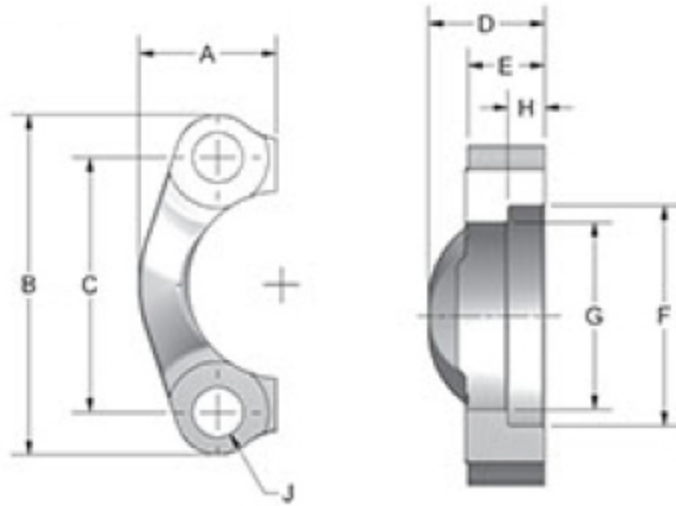

SAE J518 Split Carbon Steel Flanges

Type	Kit
Material	Carbon Steel
Code	Code 62
Flange Size	3/4 in
Dimension A	1.140 in
Dimension B	2.81 in
Dimension C	2.00 in
Dimension D	1.120 in
Dimension E	0.750 in

Dimension F	1.656 in
------------------------	----------

Dimension G	1.280 in
------------------------	----------

Dimension H	0.325 in
------------------------	----------

Dimension J	0.406 in
------------------------	----------

Mounting Hardware - O-Ring	214
---	-----

Mounting Hardware - HHCS	3/8-16 x 1.50
---	---------------