

Model 375XL, 375XLB LEAD-FREE*

Reduced Pressure Principle (1-1/4" - 2")

*This product contains a weighted average lead content less than 0.25% for wetted surfaces.

*Certified to NSF/ANSI 61-G



□ Installation □ Testing □ Maintenance Instructions

CAUTION: Installation of Backflow Preventers must be performed by qualified, licensed personnel. The installer should be sure the proper device has been selected for the particular installation. Faulty installation could result in an improperly functioning device.

ZURN WILKINS Model 375XL Reduced Pressure Principle Backflow Preventers are for use on potable water lines where a health hazard could exist if a backflow situation were to occur.

Proper performance is dependent upon following these installation instructions and prevailing governmental and industry standards and codes. Failure to do so, according to ZURN WILKINS Limited Warranty "... releases ZURN WILKINS of any liability that it might otherwise have with respect to that device." Such failure could also result in an improperly functioning device.

Damage to the device could result wherever water hammer and/or water thermal expansion could create excessive line pressure. Where this could occur, shock arresters and/or pressure relief valves should be installed downstream of the device.

1. Before installing a Model 375XL Backflow Preventer, flush the line thoroughly to remove all debris, chips and other foreign matter. If required, a strainer should be placed upstream of the Backflow Preventer.

CAUTION: Do not use a strainer in seldom used emergency waterlines such as fire lines.

2. Provide adequate space around the installed unit so that the test cocks will be accessible for testing and servicing.

3. **WARNING:** If installation of a Model 375XL is in a building, a suitable drain arrangement **MUST** be provided to drain off spillage from the relief valve. An air gap at least two times the pipe diameter must be provided between the relief valve and the drain piping to prevent a cross-connection. Air Gap AG-12 not intended to support weight of drain pipe.

CAUTION: Do not pipe the relief valve solidly to a floor drain, sewer or sump.

CAUTION: An adequately sized drain is required to prevent possible water damage due to relief valve discharge.

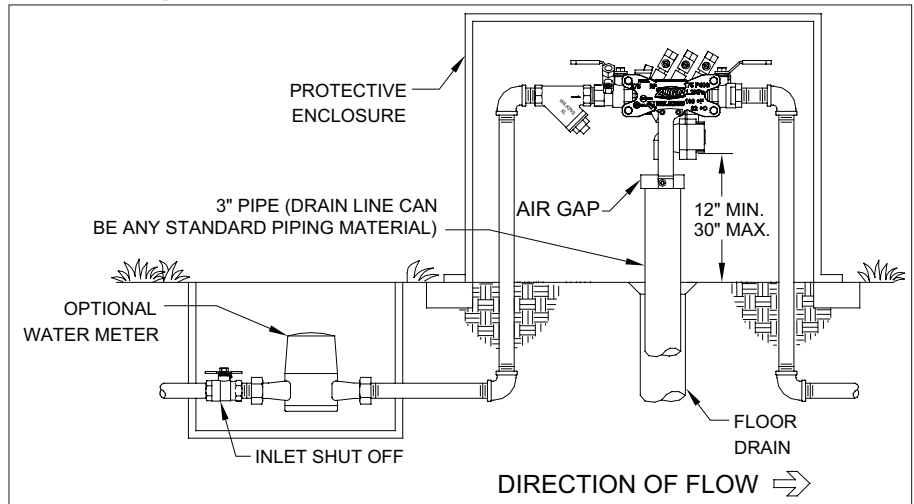

4. Install valve at least 12 inches above surrounding flood level.
5. Always consult local codes for installation methods, approvals and guidance.

OUTDOOR INSTALLATION

Model 375XL Backflow Preventers may be installed outdoors only if the device is protected against freezing conditions. Exposure to freezing conditions will result in improper function or damage to the device. The installation location must be kept above 32°F. All the basic installation instructions apply.

If installation is in a pit or vault, the Backflow Preventer must never be submerged in water because this could cause a cross-connection. Make sure that the pit or vault always remains dry by providing ample drainage.

INDOOR INSTALLATION

Indoor installation is preferred in areas that are subject to freezing conditions. All the basic installation instructions apply to such installations.

PARALLEL INSTALLATION

Where uninterrupted service from a single meter connection must be maintained, two or more Backflow Preventers may be connected in parallel. All the basic installation instructions apply to parallel installation. Be sure to allow adequate room between the units for testing and repair.

PLACING THE DEVICE IN SERVICE

After the installation of a Model 375XL has been completed, place the unit in service as follows:

375XL REDUCED PRESSURE PRINCIPLE

1. Start with both shut-off valves closed. Slowly open the inlet shut-off valve until the backflow preventer is completely pressurized. A brief discharge from the relief valve may occur while the device is pressurizing. The discharge should cease by the time the shut-off valve is fully open. Device should function properly. If the discharge does not stop, refer to "MAINTENANCE INSTRUCTIONS" for repair procedures.

2. After the device has been pressurized, vent all trapped air from both check valves by slightly opening each of the four test cocks.

3. Slowly open the downstream shut-off valve. The Model 375XL Reduced Pressure Principle Backflow Preventer is now in service.

4. If "spitting" or intermittent discharges from the relief valve are noted, it could be a result of pressure fluctuation and/or a water hammer condition in the system. If such conditions exist, install water pressure reducing valves or water hammer shock arresters in compliance with industry standards as needed.

5. After the Model 375XL has been properly installed, test the device (see "TEST PROCEDURES"). If the device fails the test, remove the first and second check valves and thoroughly flush the device. If the relief valve fails to operate properly, inspect the sensing passage for clogging (see "MAINTENANCE INSTRUCTIONS"). Clean rubber seals of all debris and place unit back in service.



Testing Procedures

MODEL 375XL REDUCED PRESSURE PRINCIPLE ASSEMBLY

Equipment Required: Differential pressure gauge test kit.

TEST NO. 1

Purpose:

Test #2 check valve for tightness against reverse flow.

Requirement:

The valve must close tight against reverse flow under all pressure differentials.

Procedure:

1. Attach the "HIGH" hose to test cock #2 and the "LOW" hose to test cock #3.
2. Close #2 shut-off valve.
3. Open test cocks #2 and #3.
4. Open by-pass valves "C" and "A" and bleed to atmosphere until all air is expelled.
5. Close by-pass valve "A". Open by-pass valve "B" and bleed to atmosphere until all air is expelled. Close by-pass valves "B" and "C".
6. Attach the "VENT" hose to test cock #4.
7. Slowly open by-pass valves "A" and "C" and keep by-pass valve "B" closed.
8. Open test cock #4.
9. Indicated pressure differential will drop slightly. If pressure differential does not continue to decrease, the #2 check valve is considered tight.

TEST NO. 2

Purpose:

Test #1 check valve for tightness and record pressure drop across #1 check valve.

Requirement:

The static pressure drop across #1 check valve shall be greater than the relief valve opening point (test #3), and at least 5.0 psid.

Procedure:

1. Close by-pass valve "A"
2. Close test cock #4, and disconnect "VENT" hose from test cock #4.
3. Open by-pass valves "B" and "C" bleeding to atmosphere, then close by-pass valve "B" restoring the system to normal static condition.
4. Observe the pressure differential gauge and note this as the #1 check valve PSID.

TEST NO. 3

Purpose:

To test operation of the differential relief valve.

Requirement:

The pressure differential relief valve must operate to maintain the "ZONE" between the two check valves at least 2 PSID less than the supply pressure.

Procedure:

1. Close by-pass valve "C" and open by-pass valve "A".
2. Open by-pass valve "B" very slowly until differential gauge needle starts to drop. Hold the valve at this position and observe the gauge reading at the moment the first discharge is noted from the relief valve. Record this as the opening differential pressure of the relief valve.

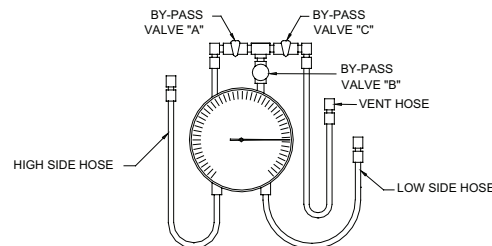
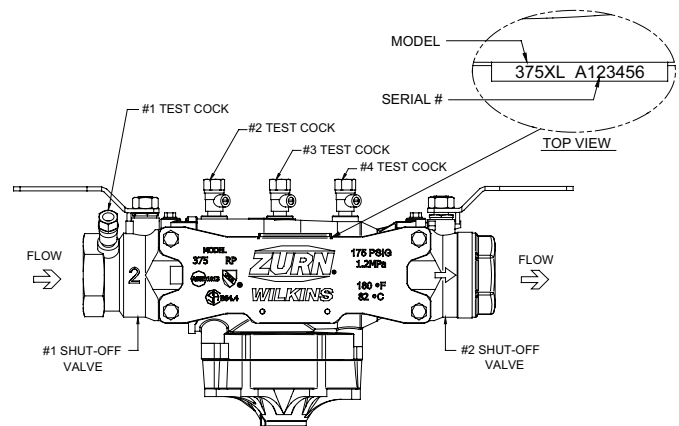

Maintenance Instructions

All Model 375XL Reduced Pressure Principle Backflow Preventers must be inspected and maintained by licensed personnel at least once a year or more frequently as specified by local codes. Replacement of worn or damaged parts must only be made with genuine "ZURN WILKINS" parts. The ZURN WILKINS Certificate of Limited Warranty provides that failure to do so "...releases ZURN WILKINS of any liability that it might otherwise have with respect to that device." Such failure could also result in an improperly functioning device.

The Model 375XL Reduced Pressure Principle Assemblies should be thoroughly flushed after backflow conditions occur to prevent any type of corrosive deterioration to its components. Failure to do so could result in malfunction of the device.

GENERAL MAINTENANCE

1. Clean all parts thoroughly with water after disassembly.

2. Carefully inspect rubber seal rings, diaphragms and o-rings for damage.
3. Test unit after reassembly for proper operation (see "Testing Procedures").

SERVICING CHECK VALVES

1. Close inlet and outlet shut-off valves.
2. Open No. 2, No. 3 and No. 4 test cocks to release pressure from valve.
3. Unscrew 4 screws holding body down lift valve body upward.
4. Twist and remove sleeve from body. Using finger or blunt object, push in outlet end of body, both checks should slide out the body inlet. A short object like a socket can be placed on a flat surface. Place body over object so it pushes into valve outlet and push down on body.
5. Twist spring retainers counter-clockwise to remove from seat and access poppets.
6. Inspect the rubber seal ring for cuts or embedded debris. To remove seal ring, remove screw and seal ring retainer.

Maintenance Instructions

If the reverse side of the seal ring is unused, it is possible to invert the seal ring. This would be considered a temporary solution to fixing a fouled check and should be replaced with a new seal ring as soon as possible.

7. Inspect seat surface for nicks or dings and replace if necessary. Use fingernail to check for dings. Re-grease seat o-rings.
8. Inspect seat o-ring sealing areas in body and wipe clean.
9. Reverse the above procedures to reinstall check valve assembly. Drop #2 check assembly in body. Then drop #1 check assembly in and turn until #1 spring retainer lines up with #2 seat. Then push both assemblies into body. Insert sleeve against checks. (Place sleeve down against flat surface and push on body with rocking motion.) Care should be taken to make sure the heavy spring is installed in the No. 1 check valve.
10. Rock body side to side to help o-rings slide in. If it does not drop in completely, do not use screws to force it. An overly greased o-ring might slide out of groove at top of ball valve. Use a screw driver to push o-ring back in groove, then push body down in.

SERVICING RELIEF VALVE

1. Remove three bolts holding relief valve module to body.
2. Pull down and remove relief module to expose seat and seal ring. These can be inspected without further disassembly. CAUTION: do not lose small o-ring or large o-ring that fit between module and check body.
3. To inspect diaphragm or replace seat/diaphragm stem assembly, remove the four screws holding the two module halves together. CAUTION: do not lose small o-ring.
4. Remove stem assembly. Inspect diaphragm and plunger o-ring for damage. Replace any damaged parts and apply a light coat of grease to plunger o-ring and place on plunger. CAUTION: stem assembly is internally spring loaded. Seat can be unscrewed from plunger to replace diaphragm or spring. The seat surface must not be nicked during disassembly or reassembly.
5. There are two o-rings that fit into the cover surface, one large, one small. These o-rings should not be greased. Insert stem into cover. Place second module half onto cover. Push the seat down into the cover with your thumb to align diaphragm bolt holes with cover and then insert four bolts and tighten.
6. Inspect o-ring that seals between module and check body. Replace if necessary. Apply grease to the o-ring and then place on step on check body. Place small o-ring into groove between the two front bolts holes in relief valve module.
7. Slide relief valve module onto check body. Rocking side to side can help it slide on over o-ring. Replace three remaining bolts.
8. Place device in service and test per "TESTING PROCEDURES".

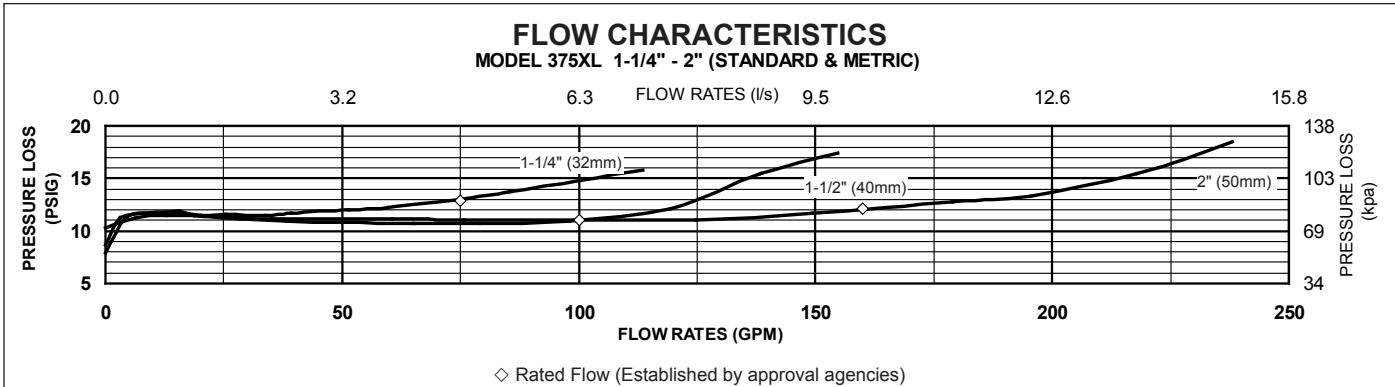
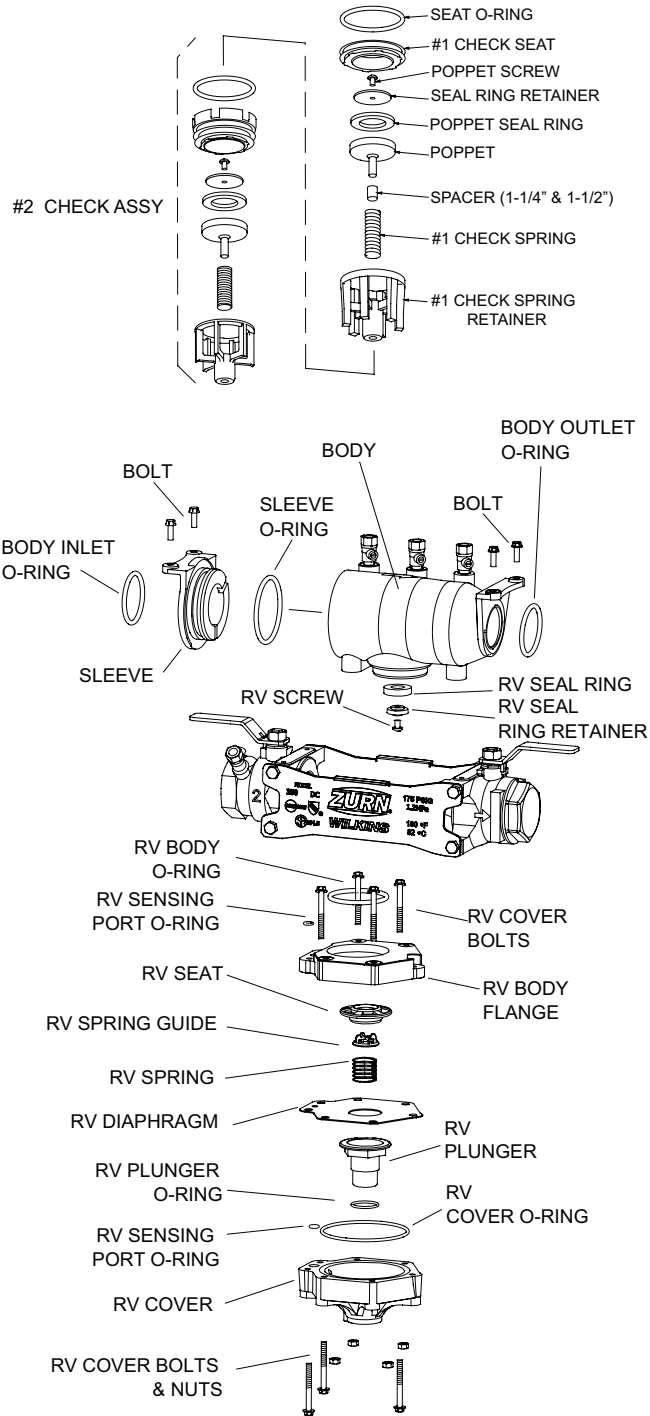

Troubleshooting

When the relief valve discharges intermittently it can be almost always assumed that the device is functioning correctly and that the discharge is caused by systems problem such as inlet pressure fluctuations or water hammer due to quick closing valves.

<u>PROBLEM</u>	<u>POSSIBLE CAUSES</u>	<u>CORRECTIVE ACTION</u>
1. SUDDEN OR RAPID SPITTING	<ol style="list-style-type: none"> Drop in inlet pressure. Sudden increase in downstream pressure due to water hammer from quick closing shut-off valve installed downstream. 	<ol style="list-style-type: none"> Install an in-line spring loaded check valve upstream of backflow. Install pressure reducing valve up stream of backflow unit. Install in-line spring loaded check valve downstream of backflow as close to source as possible, but not closer than 4 feet.
2. LIGHT INTERMITTENT DRIP	<ol style="list-style-type: none"> Slightly fouled #1 check 	<ol style="list-style-type: none"> Clean #1 check and turn check valve seal ring over or replace.

Continuous discharge of the relief valve signifies a failure of some part of the device. To help determine the specific area of failure, close the #2 shut-off valve. If the discharge stops, the #2 check requires service. If the discharge continues, the #1 check requires service.

1. CONTINUOUS DISCHARGE	<ol style="list-style-type: none"> Fouled #1 check. Fouled relief valve seat. Fouled #2 check. 	<ol style="list-style-type: none"> Clean check valves and turn check valve seal rings over or replace. Clean relief valve seat and turn relief valve seal ring over or replace.
--------------------------------	---------------------------------------------------------------------------------------------------------------------------------	---------------------------------------------------------------------------------------------------------------------------------------------------------------------------------------------------------

In summation, the amount of discharge is proportional to degree of fouling. Most problems occur in the #1 check which is where debris enters the backflow preventer first.

Performance Characteristics

SPECIFICATIONS

Maximum working water pressure	175PSI
Maximum working water temperature	180°F
Hydrostatic test pressure	350PSI
End connections	Threaded NPT ANSI B1.20.1

Capacity thru Schedule 40 Pipe				
Pipe size	5 ft/sec	7.5 ft/sec	10 ft/sec	15 ft/sec
1/2"	5	7	9	14
3/4"	8	12	17	25
1"	13	20	27	40
1 1/4"	23	35	47	70
1 1/2"	32	48	63	95
2"	52	78	105	167

Relief Valve Discharge Rates

(Worst case condition - If 1st check or relief valve is lodged wide open)

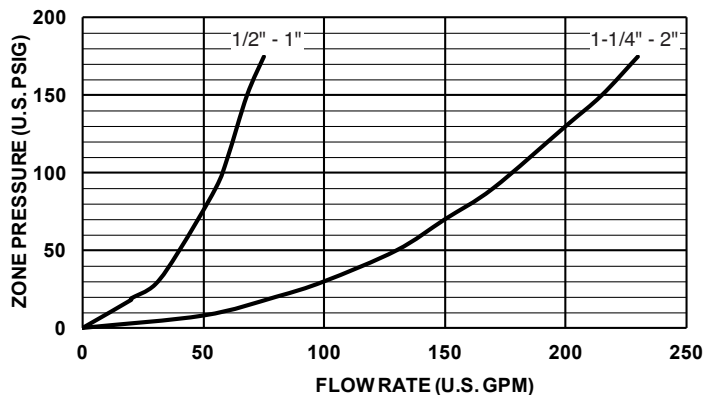

REPAIR KIT FOR 375XL's

RUBBER PARTS

1-1/4" - 2" RK114-375R

COMPLETE INTERNALS

1-1/4" - 2" RK114-375

VESSEL

1-1/4" - 2" RK114-375V

Proper performance is dependent upon licensed, qualified personnel performing regular, periodic testing according to ZURN WILKINS' specifications and prevailing governmental & industry standards and codes and upon following these installation instructions. Failure to do so releases ZURN WILKINS of any liability that it might otherwise have with respect to that device. Such failure could also result in an improperly functioning device.

WARNING: This product contains a chemical known to the State of California to cause cancer, birth defects and other reproductive harm

ADVERTENCIA: Este producto contiene una sustancia química que el Estado de California como causante de cáncer, defectos de nacimiento y otros daños reproductivos



1747 Commerce Way, Paso Robles, CA 93446 Phone:855-663-9876 Fax:805-238-5766

ZURN WILKINS

www.zurn.com