

M-12147

3

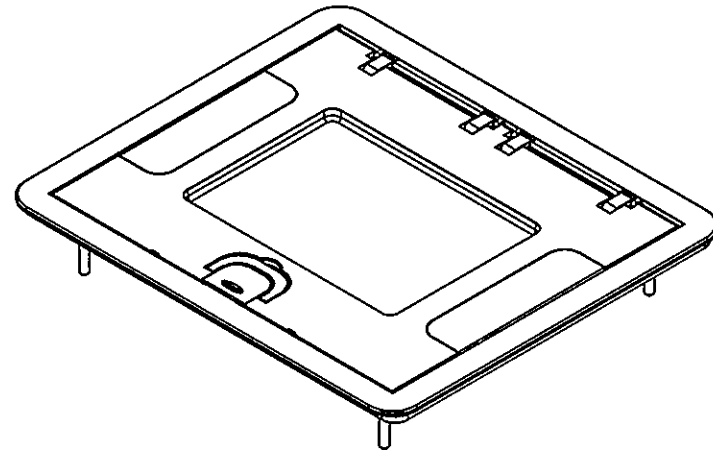

RECESS

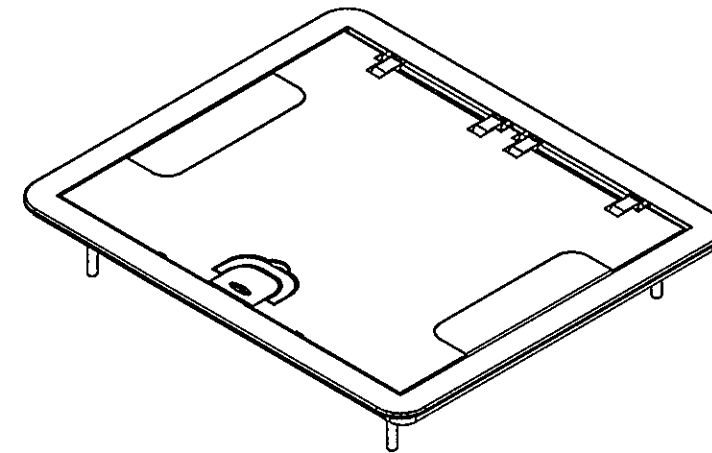

NO RECESS

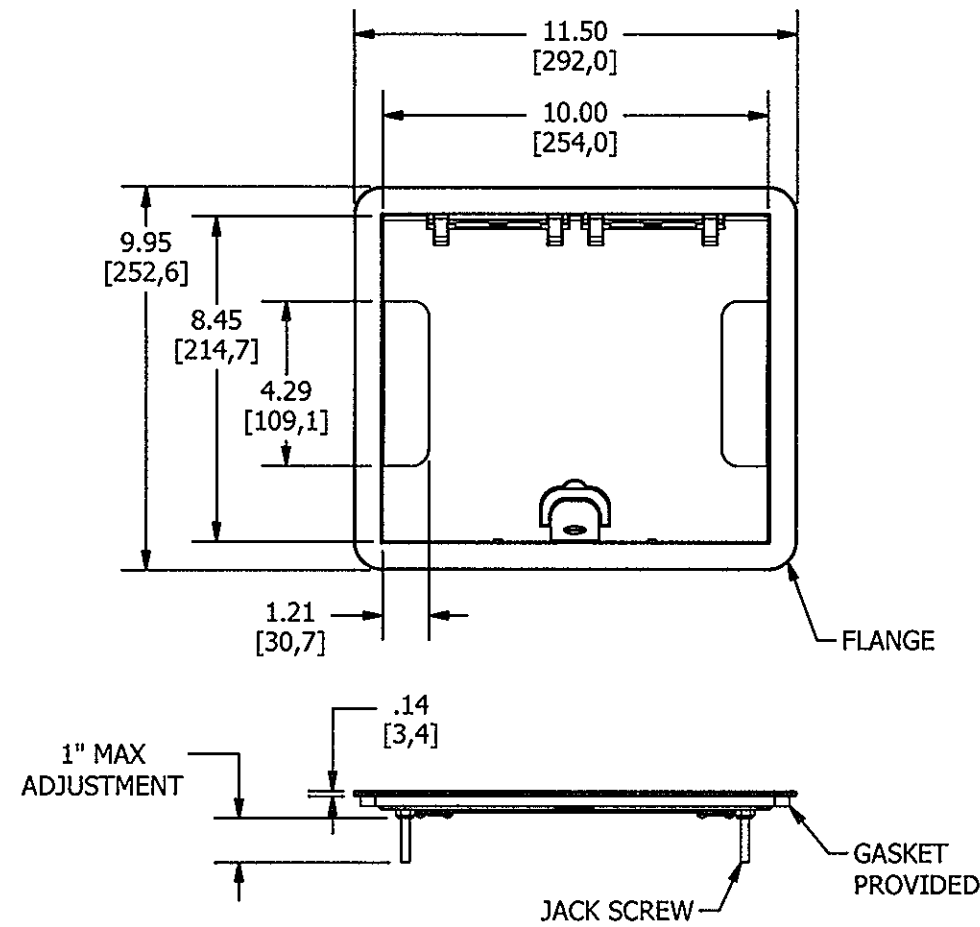
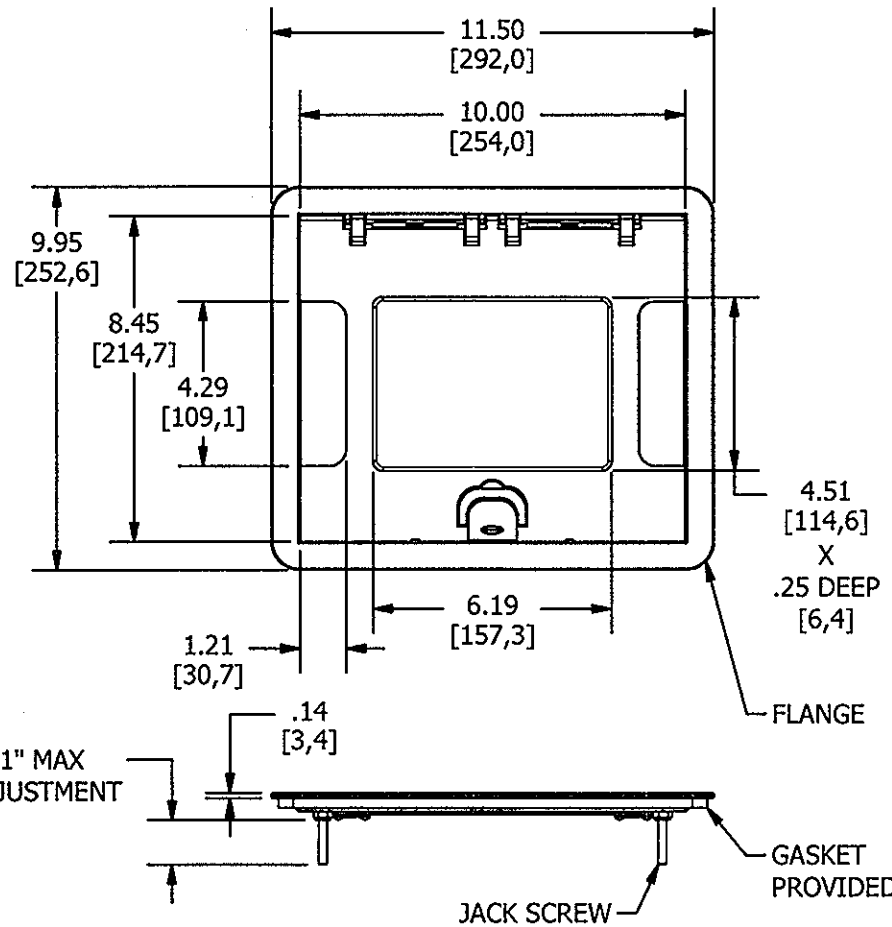

RECESS	
CATALOG NO.	COLOR
610GCCVRNKC	NICKEL
610GCCVRBKC	BLACK
610GCCVRALUC	ALUMINUM
610GCCVRBRSC	BRASS
610GCCVRBRZC	BRONZE

NO RECESS	
CATALOG NO.	COLOR
610GCCVRNK	NICKEL
610GCCVRBK	BLACK
610GCCVRALU	ALUMINUM
610GCCVRBRS	BRASS
610GCCVRBRZ	BRONZE

NOTES: UNLESS OTHERWISE SPECIFIED:
 1. DIMENSIONS SHOWN ON THIS DRAWING ARE NOMINAL VALUES FOR GENERAL USE ONLY.
 2. PRODUCT IS cULus LISTED.

LIST OF PARTS

DESCRIPTION	MATERIAL	FINISH
FLANGE	ALUMINUM	POWDER COAT
COVER	ALUMINUM	POWDER COAT
GASKETS	CLOSED CELL FOAM	
HINGE SUPPORT	ALUMINUM	POWDER COAT
PIVOT LINK	ALUMINUM	POWDER COAT
HINGE PIN LONG	STAINLESS	
HINGE PIN SHORT	STAINLESS	
SUPPORT HINGE PIN	CRS	PRE GALVANIZED
DOOR STRAP	CRS	PRE GALVANIZED
EGRESS DOOR	ALUMINUM	POWDER COAT
EGRESS DOOR SPRING	STAINLESS	
BUTTON SLIDE	ALUMINUM	POWDER COAT
SPRING BUTTON	STAINLESS	
LATCH	ALUMINUM	POWDER COAT
JACK SCREW	STEEL WIRE	ZINC PLATED
JACK SCREW NUT	CRS	ZINC PLATED

SYM	DESCRIPTION	APP.	DATE
3	ADDED ISO VIEWS PER DCN # 20587 MAM RGP RGP	TLS	6/13/2014
2	REDRAWN IN INVENTOR, UPDATED DRAWING TO MATCH UG MODEL PER DCN # 20081 RGP TLS	TLS	09/20/13
1	RELEASED FOR PRODUCTION PER DCN # 18427 MJM TLS	TLS	01/19/12

THE DESIGN AND DIMENSIONS OF THE PRODUCT SHOWN ON THIS DRAWING ARE SUBJECT TO CHANGE WITHOUT NOTICE

TITLE
 6 & 10 GANG CARPET COVER ASSY. RECESS & NO RECESS

TOLERANCES UNLESS OTHERWISE SPECIFIED	WIRING DEVICE-KELLEMS HUBBELL INCORPORATED SHELTON, CT			
FRACTIONS ±1/64	DR. BY RGP	APP. BY TLS		
DECIMALS ±.03	TR. BY	SCALE 1:4		
ANGLES ±2°	CHK'D BY TLS	DATE 9/10/2013		

DIMENSION SHEET FOR CAT. NO. SEE TABLE REPAIRABLE NON-REPAIRABLE B M-12147 3