

M-12487

2

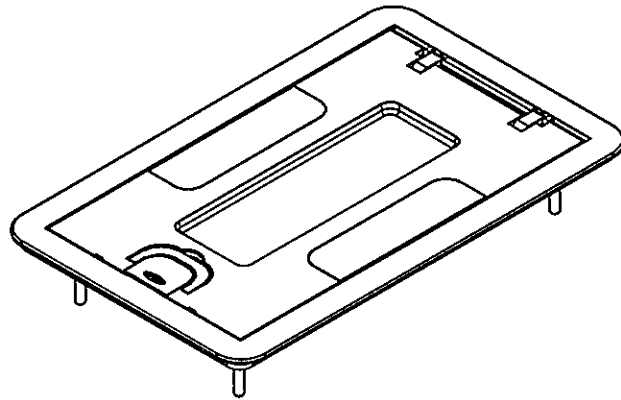

**RECESS**

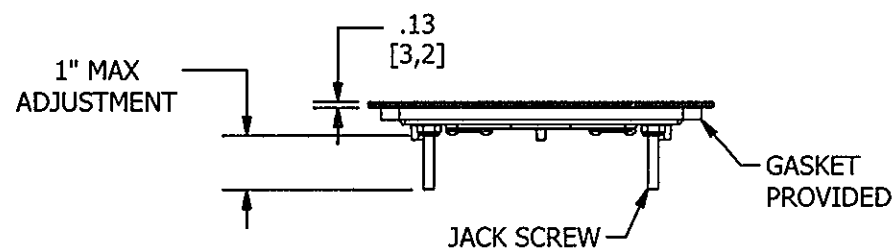
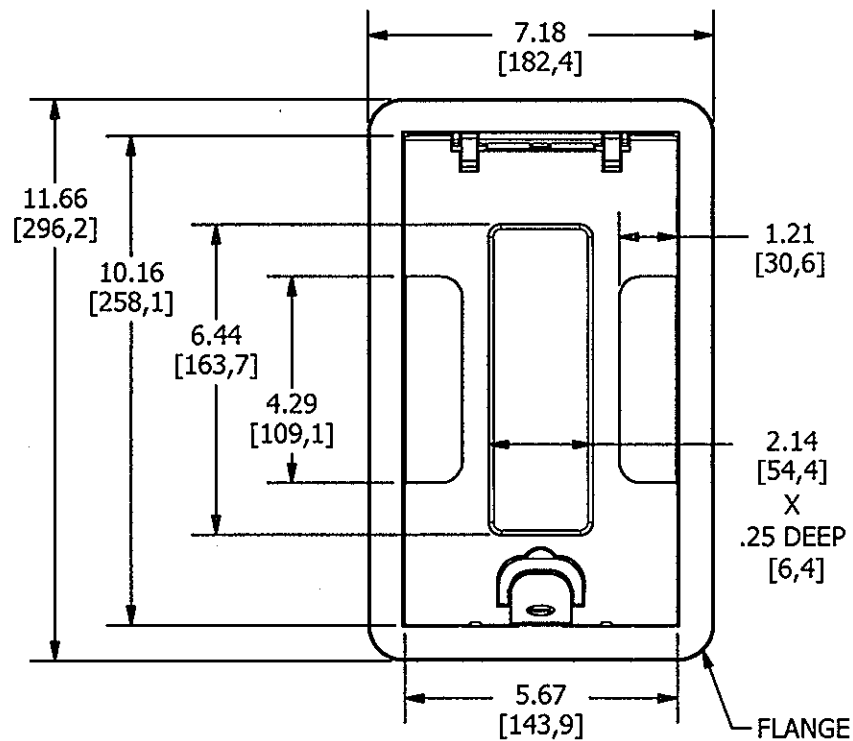

RECESS	
CATALOG NO.	COLOR
24GCCVRNKC	NICKEL
24GCCVRBKC	BLACK
24GCCVRALUC	ALUMINUM
24GCCVRBRSC	BRASS
24GCCVRBRZC	BRONZE

NOTES: UNLESS OTHERWISE SPECIFIED:  
 1. DIMENSIONS SHOWN ON THIS DRAWING ARE NOMINAL VALUES FOR GENERAL USE ONLY.  
 2. PRODUCT IS cULus LISTED.

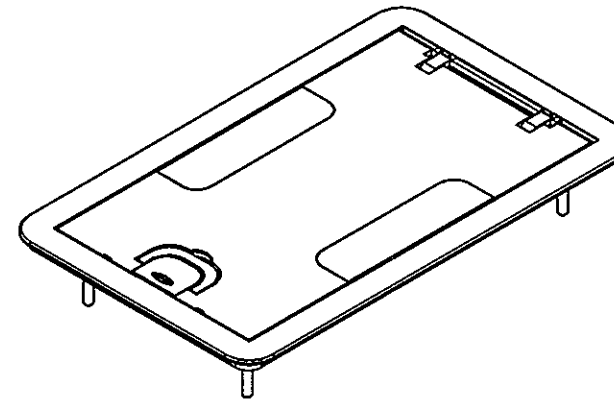

**NO RECESS**

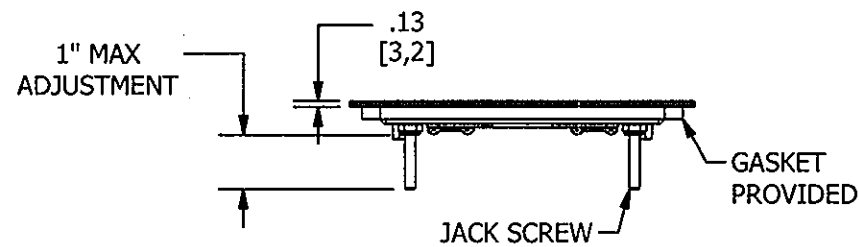
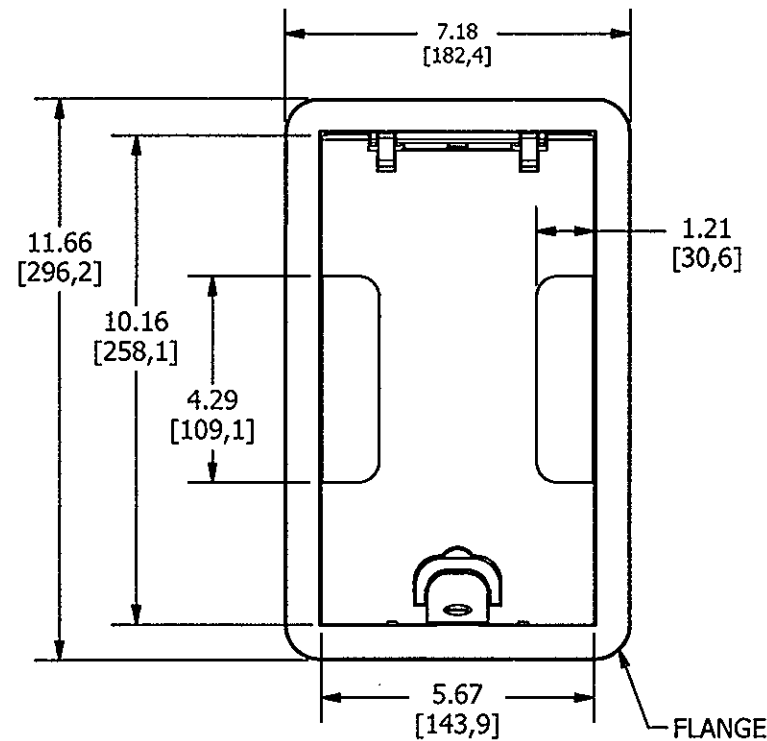

NO RECESS	
CATALOG NO.	COLOR
24GCCVRNK	NICKEL
24GCCVRBK	BLACK
24GCCVRALU	ALUMINUM
24GCCVRBRS	BRASS
24GCCVRBRZ	BRONZE

LIST OF PARTS

DESCRIPTION	MATERIAL	FINISH
FLANGE	ALUMINUM	POWDER COAT
COVER	ALUMINUM	POWDER COAT
GASKETS	CLOSED CELL FOAM	
HINGE SUPPORT	ALUMINUM	POWDER COAT
PIVOT LINK	ALUMINUM	POWDER COAT
HINGE PIN LONG	STAINLESS	
HINGE PIN SHORT	STAINLESS	
SUPPORT HINGE PIN	CRS	PRE GALVANIZED
DOOR STRAP	CRS	PRE GALVANIZED
EGRESS DOOR	ALUMINUM	POWDER COAT
EGRESS DOOR SPRING	STAINLESS	
BUTTON SLIDE	ALUMINUM	POWDER COAT
SPRING BUTTON	STAINLESS	
LATCH	ALUMINUM	POWDER COAT
JACK SCREW	STEEL WIRE	ZINC PLATED
JACK SCREW NUT	CRS	ZINC PLATED

DIMENSION SHEET FOR CAT. NO.

SEE TABLE

REPAIRABLE

NON-REPAIRABLE

2	ADDED ISO VIEWS PER DCN # 20587 MAM RGP RGP	TLS	6/13/2014
1	RELEASED FOR PRODUCTION PER DCN # 20081 RGP TLS	TLS	09/20/13
SYM	DESCRIPTION	APP.	DATE

THE DESIGN AND DIMENSIONS OF THE PRODUCT SHOWN ON THIS DRAWING ARE SUBJECT TO CHANGE WITHOUT NOTICE

TITLE  
 2 & 4 GANG CARPET COVER ASSY.  
 RECESS & NO RECESS

TOLERANCES UNLESS OTHERWISE SPECIFIED  
 FRACTIONS ±1/64  
 DECIMALS ±.03  
 ANGLES ±2'

WIRING DEVICE-KELLEMS  
 HUBBELL INCORPORATED  
 SHELTON, CT

DR. BY	RGP	APP. BY	TLS
TR. BY		SCALE	1 : 4
CHK'D BY	TLS	DATE	9/10/2013

**B**

**M-12487**

2