

M-11713 1

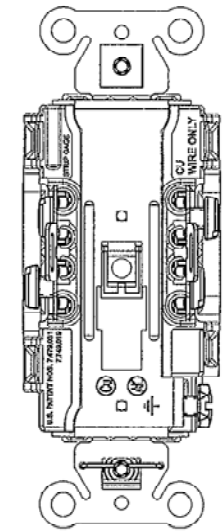
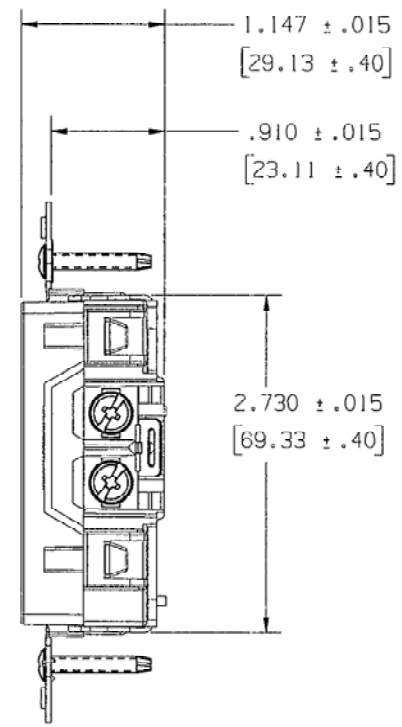
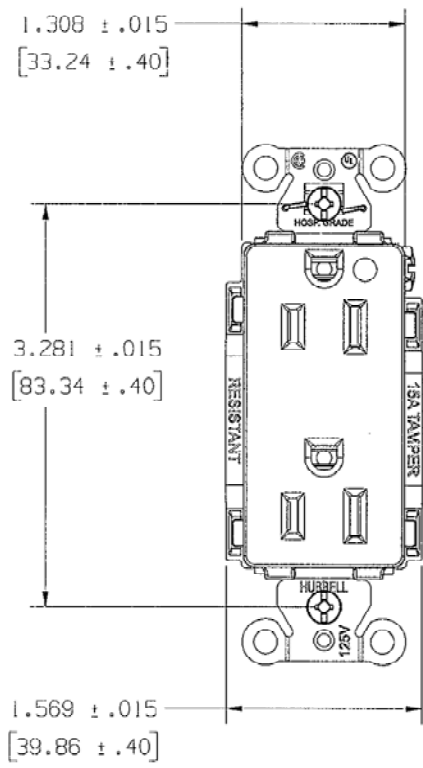

- NOTES:
 1) DIMENSIONS ARE IN INCHES (MM).
 2) ALL DEVICES UL LISTED AND CSA CERTIFIED.
 3) TERMINALS ACCOMMODATE #14-#10 AWG COPPER WIRE ONLY.

| CATALOG NUMBERS | | | | | | | | | | | |
|-----------------|--------|----------|----------|---------|----------|-----------|--------------|--------------|--------|-----------|-------|
| | BROWN | IVORY | GRAY | WHITE | BLACK | ALMOND | LIGHT ALMOND | OFFICE WHITE | ORANGE | RED | BLUE |
| 15A | 2172TR | 2172IVTR | 2172GYTR | 2.72WTR | 2172BKTR | 2172ALMTR | 2172LATR | ----- | ----- | 2172REDTR | ----- |
| 20A | 2182TR | 2182IVTR | 2182GYTR | 2.82WTR | 2182BKTR | 2182ALMTR | 2182LATR | ----- | ----- | 2182REDTR | ----- |

| LIST OF PARTS | | |
|---------------------|--------------|----------|
| DESCRIPTION | MATERIAL | FINISH |
| TOP | NYLON 6/6 | SP1 A-3 |
| BASE | NYLON 6/6 | SP1 A-3 |
| LINE CONTACTS | BRASS | |
| GROUND CONTACTS | BRASS | |
| CONTACT SCREW (NEU) | STEEL | NI PLT |
| CONTACT SCREW (H01) | STEEL | |
| BRIDGE | .04 GALV STL | |
| GROUND SCREW | STEEL | GREEN |
| STAPLE | S.S. | |
| WASHER | PVC FILM | BLACK |
| MOUNTING SCREW | STEEL | ZINC PLT |

| | | |
|---|-----------------------------------|----------|
| 1 | RELEASED PER DCN #18840 WRV WJ | 05/08/12 |
|---|-----------------------------------|----------|

| SYM | REVISIONS | APP | DATE |
|-----|-----------|-----|------|
|-----|-----------|-----|------|

THE DESIGN AND DIMENSIONS OF THE PRODUCT SHOWN ON THIS DRAWING ARE SUBJECT TO CHANGE WITHOUT NOTICE

TITLE HOSPITAL GRADE DECORATOR RECEPTACLE
 15A & 20A 125V, 2P3W
 TAMPER RESISTANT
 BACK & SIDE WIRE

| | | |
|---|--|-------------|
| TOLERANCES UNLESS OTHERWISE SPECIFIED .XX : ±.01 .XXX : ±.005 ANGLES : ±2° | WIRING DEVICE-KELLEMS HUBBELL INCORPORATED SHELTON, CT | |
| | DR. BY WRV | APP. BY |
| | TR. BY | SCALE 1:1 |
| | CHK. BY | DATE 5/2012 |