

REVISION HISTORY			
REV	DESCRIPTION	BY	DATE
A	ECO# 20160606-1L	WF	04/27/2017

- NOTES:**
1. ALL DIMENSIONS ARE FROM OUTSIDE UNLESS OTHERWISE NOTED (I/S).
  2. ENCLOSURE IS FABRICATED FROM 10 GA. 304 STAINLESS STEEL.
  3. ALL SEAMS ARE CONTINUOUSLY WELDED & GROUND SMOOTH.
  4. DOORS ARE SEALED WITH FOAM-IN-PLACE GASKET.
  5. RIGHT DOOR (MASTER) IS SECURED SHUT WITH A 3-POINT 316 S.S. PADLOCKABLE HANDLE WITH BUILT IN DEFEATER.
  6. LEFT DOOR (SLAVE) IS SECURED SHUT WITH A 3-POINT 316 S.S. PADLOCKABLE HANDLE WITHOUT DEFEATER.
  7. A 10 GA. CARBON STEEL BACK PANEL IS INSTALLED PER DRAWING.
  8. FINISH: EXTERIOR - STANDARD GRAINED FINISH.  
INTERIOR - STANDARD COMMERCIAL FINISH.  
PANEL - WHITE POLYESTER POWDER (SMOOTH).
  9. ENCLOSURE IS RATED UL TYPE 4X.

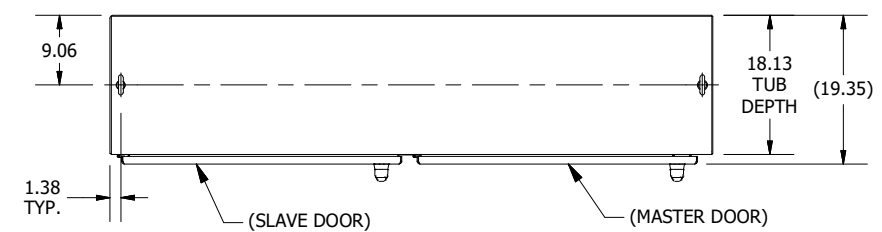

**TOP VIEW**

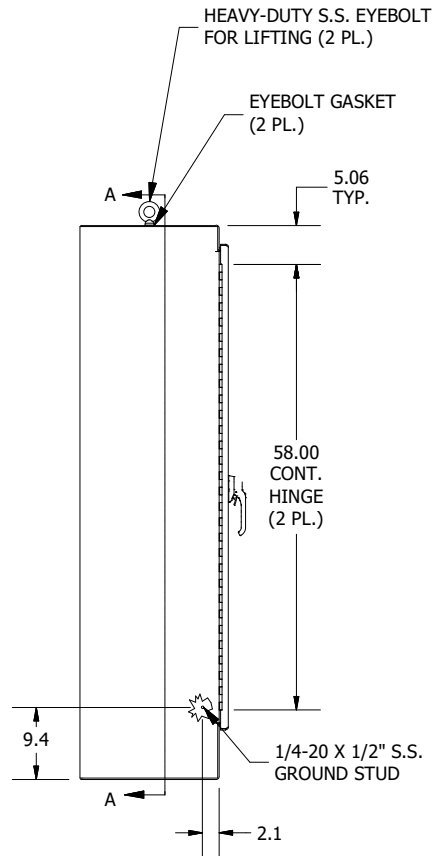

**LEFT SIDE VIEW**

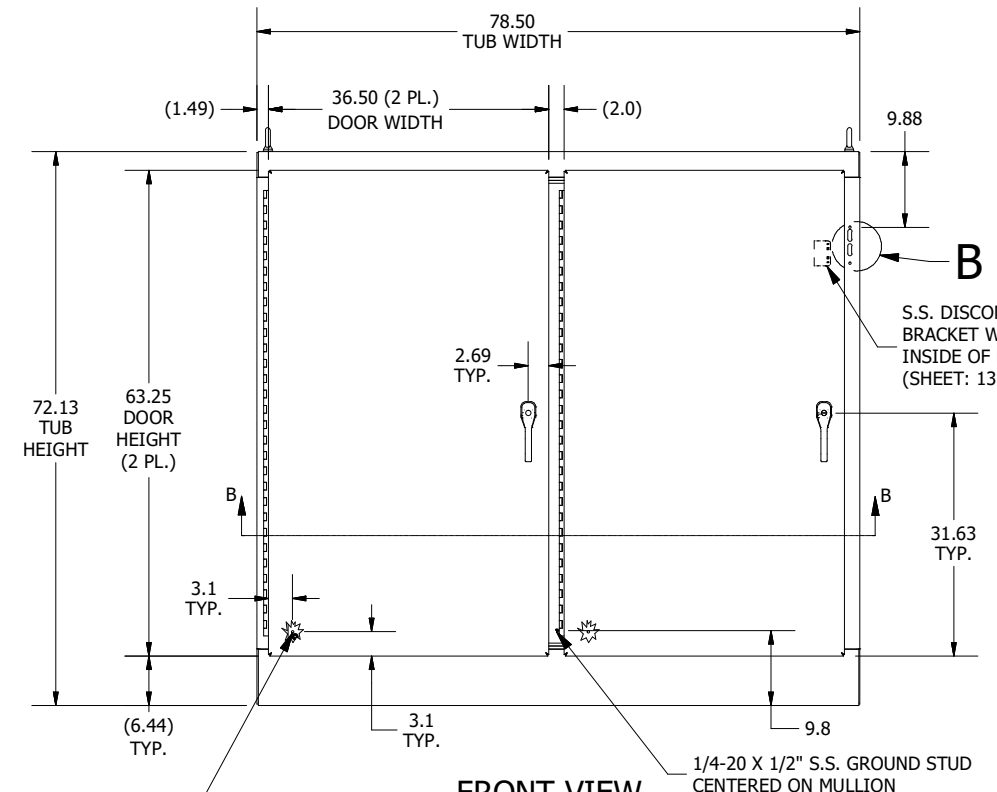

**FRONT VIEW**

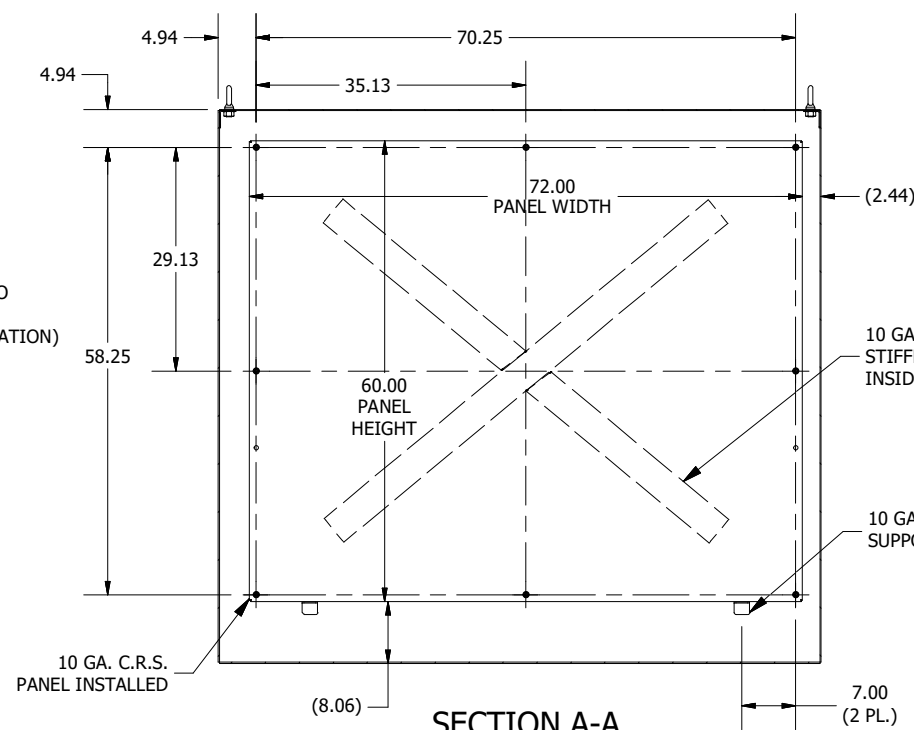

**SECTION A-A  
(INSIDE BACK OF ENCL.)**

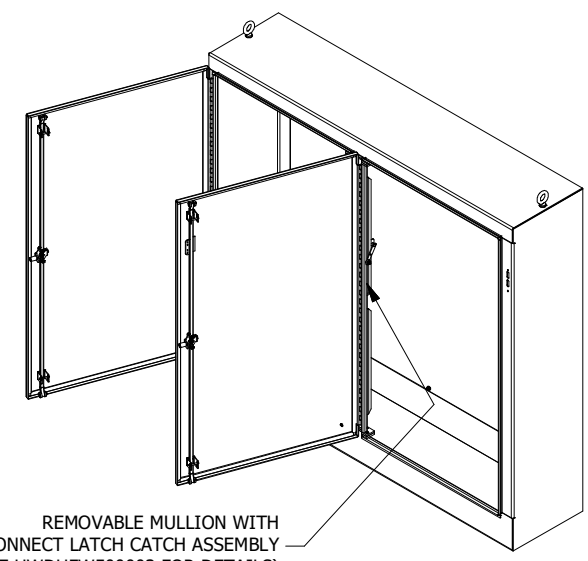

REMOVABLE MULLION WITH DISCONNECT LATCH CATCH ASSEMBLY (SEE HWDHFW500003 FOR DETAILS)

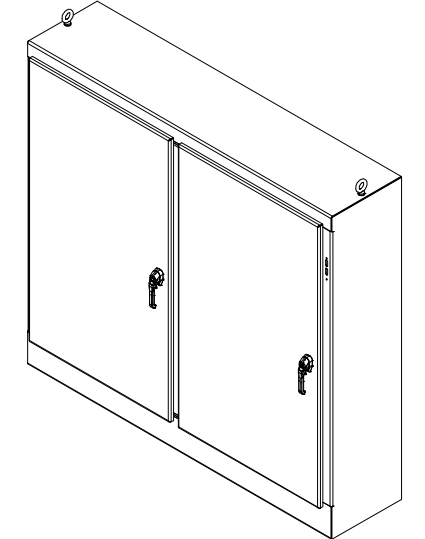

10 GA. 304 S.S. CROSS STIFFENERS WELDED TO INSIDE BACK OF ENCL.

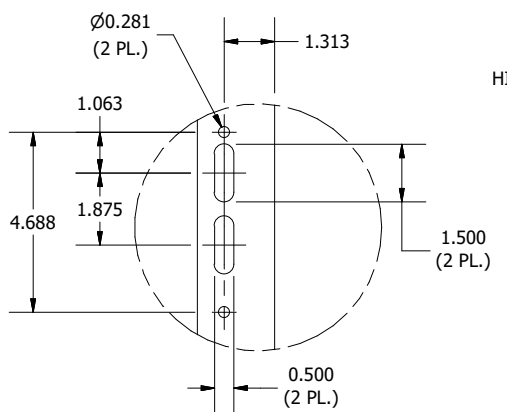

**DETAIL B  
(DISCONNECT CUTOUT DETAIL)**

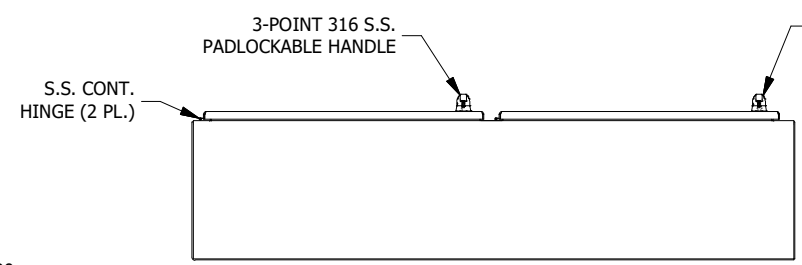

**BOTTOM VIEW**

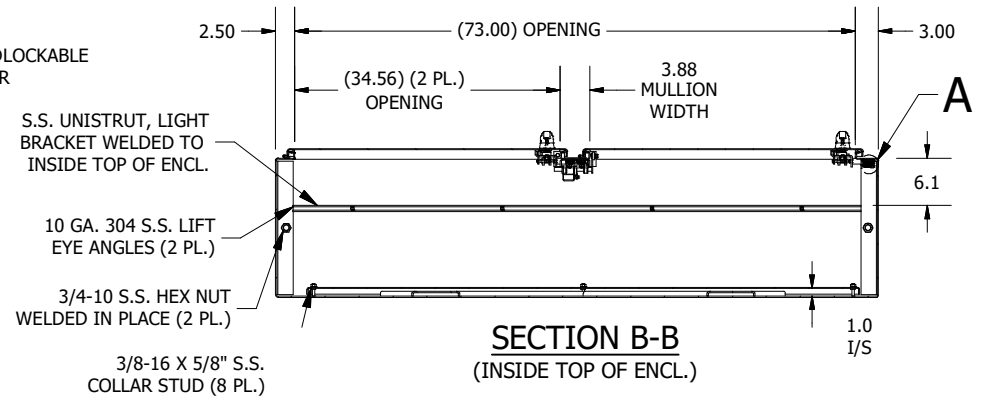

**SECTION B-B  
(INSIDE TOP OF ENCL.)**

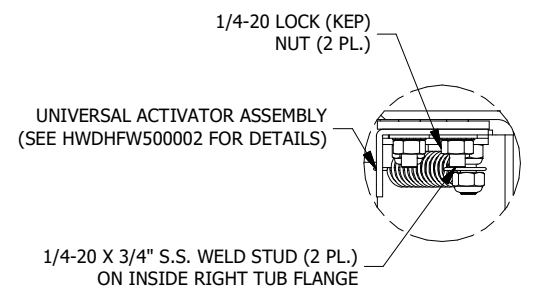

**DETAIL A  
(UNIV. ACTIVATOR INSTALL)**

PART#: WA72XM7718SSN4  
(DATA SUBJECT TO CHANGE WITHOUT NOTICE)