



Compact Ball Valves



Features – PVC, CPVC

This industrial grade, quarter turn shutoff valve is popular where maintenance-free installations are desired for a variety of chemical processing, industrial and OEM applications. IPS Sizes 1/2" - 4" available with socket, threaded or flanged end connectors, 6" size available with socket or flanged end connectors. 6" valve uses high-efficiency lever style handle for easier operation.

- Chemical & Corrosion Resistant PVC or CPVC Construction
- Maintenance-Free Sealed Unit
- Schedule 80 Full-Bore Design
- High Impact Polypropylene Handle
- Spears® Single O-ring Safe-T-Shear® Stem Design
- EPDM or FKM O-rings
- Self Adjusting PTFE Floating Seat Design
- Sizes 1/2" - 2" Pressure Rated to 235 psi @ 73°F, Sizes 3" - 6" and all Flanged Pressure Rated to 150 psi @ 73°F
- EPDM valves NSF® Certified for Potable Water use
- Suitable for Vacuum Service
- Assembled with Silicone-Free, Water Soluble Lubricant
- Manufactured to ASTM F 1970

Note: Valve size 6" uses Lever Handle (not shown)

Sample Engineering Specification

All thermoplastic ball valves shall be Compact sealed unit type constructed from PVC Type I, ASTM D 1784 Cell Classification 12454 or CPVC Type IV, Cell Classification 23447. All O-rings shall be EPDM or FKM. All valves shall have Safe-T-Shear® stem and Polypropylene handle. All EPDM valves shall be certified by NSF International for use in potable water service. All 1/2" - 2" valves shall be pressure rated at 235 psi, all 3" - 6" and all flanged valves shall be pressure rated at 150 psi for water at 73°F, as manufactured by Spears® Manufacturing Company.

Quick-View Valve Selection Chart

Valve Size	O-ring Material	PVC Part Numbers ¹			Pressure Rating	
		Socket	Threaded	Flanged		
1/2	EPDM	2122-005	2121-005	2123-005	235 psi Non-Shock Water @ 73°F	
	FKM	2132-005	2131-005	2133-005		
3/4	EPDM	2122-007	2121-007	2123-007		
	FKM	2132-007	2131-007	2133-007		
1	EPDM	2122-010	2121-010	2123-010		
	FKM	2132-010	2131-010	2133-010		
1-1/4	EPDM	2122-012	2121-012	2123-012		(Flanged 150 psi Non-Shock) Water @ 73°F
	FKM	2132-012	2131-012	2133-012		
1-1/2	EPDM	2122-015	2121-015	2123-015		
	FKM	2132-015	2131-015	2133-015		
2	EPDM	2122-020	2121-020	2123-020		
	FKM	2132-020	2131-020	2133-020		
3	EPDM	2122-030	2121-030	2123-030	150 psi Non-Shock Water @ 73°F	
	FKM	2132-030	2131-030	2133-030		
4	EPDM	2122-040	2121-040	2123-040		
	FKM	2132-040	2131-040	2133-040		
6	EPDM	2122-060	---	2123-060		
	FKM	2132-060	---	2133-060		

¹: For CPVC valves, add the letter "C" to the part numbers listed (e.g., 2131-005C).

Optional Accessories*

- Round Safety Handle
- Stem Extension Kit
- Mini-Mount Actuation Mounting Kit
- 2" Square/T-Style Operator Nut

*See "BALL VALVE ACCESSORIES" section for details of individual products.

Compact Ball Valves

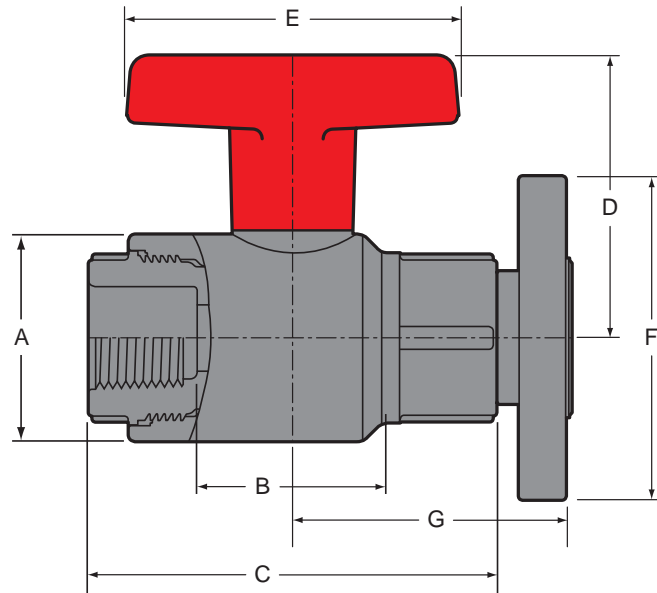

Dimensions, Weights, Operating Torque & C_v Values

Nominal Size	Dimension Reference (inches, ± 1/16)								Approx. Wt. (Lbs.)		Oper. ² Torque (in.-lb.)	C _v ³ Values	
	A	B ¹		C	D	E ⁴	F	G	PVC	CPVC		Soc/Thd	Flanged
		Socket	Threaded										
1/2	1-11/16	1-5/8	1-7/8	3-3/8	2-5/16	2-3/4	3-1/2	2-17/32	.31	.32	20	36	20
3/4	2-1/8	1-15/16	2-7/16	4-1/16	2-11/16	3-1/4	3-7/8	2-27/32	.49	.52	30	74	42
1	2-7/16	2-1/16	2-3/8	4-7/16	2-7/8	3-3/4	4-1/4	3-1/16	.64	.69	40	141	80
1-1/4	2-13/16	2-3/8	3	4-15/16	3-5/16	4-1/8	4-5/8	3-13/32	.93	.98	60	284	163
1-1/2	3-1/4	2-13/16	3-1/2	5-5/8	3-11/16	4-1/2	5	4	1.39	1.45	80	402	229
2	4-1/16	3-3/8	4-7/16	6-1/2	4-3/8	5-1/4	5-7/8	4-13/32	2.33	2.45	90	706	429
3	5-5/16	4-9/16	5-1/2	8-5/16	5-1/2	7-21/32	7-1/2	5-7/16	4.49	5.02	300	1660	1079
4	7-3/8	6-3/16	7-3/16	10-5/32	6-5/8	10-27/32	9-1/16	6-7/8	9.50	10.24	400	3104	2028
6 ⁴	10-3/16	8	10-3/4	14-1/8	8-1/16	14-5/16	11-1/4	8-21/32	21.48	23.41	900	7942	5268

1: Valve Lay Length

2: Torque required at valve maximum internal pressure rating, 5 ft./sec. flow velocity.

3: Gallons per minutes at 1 psi pressure loss. Values calculated from valve laying length, based on derivative of Hazen-Williams equation with surface roughness factor of C = 150.

4: 6" valve has lever handle, dimension is from valve centerline (not illustrated)

Temperature Pressure Rating

System Operating Temperature °F (°C)		100 (38)	110 (43)	120 (49)	130 (54)	140 (60)	150 (66)	160 (71)	170 (77)	180 (82)	190 (88)	200 (93)	210 (99)	
Valve Pressure Rating psi (MPa)	1/2" - 2"	PVC	235 (1.62)	211 (1.45)	150 (1.03)	75 (.52)	50 (.34)	-0- (-0-)	-0- (-0-)	-0- (-0-)	-0- (-0-)	-0- (-0-)	-0- (-0-)	
		CPVC	235 (1.62)	219 (1.51)	170 (1.17)	145 (1.00)	130 (.90)	110 (.76)	90 (.62)	80 (.55)	70 (.48)	60 (.41)	50 (.34)	-0- (-0-)
	3" - 6"	PVC	150 (1.03)	135 (.93)	110 (.76)	75 (.52)	50 (.34)	-0- (-0-)	-0- (-0-)	-0- (-0-)	-0- (-0-)	-0- (-0-)	-0- (-0-)	-0- (-0-)
		CPVC	150 (1.03)	140 (.97)	130 (.90)	120 (.83)	110 (.76)	100 (.70)	90 (.62)	80 (.55)	70 (.48)	60 (.41)	50 (.34)	-0- (-0-)