

PVC BALL VALVE, THREADED

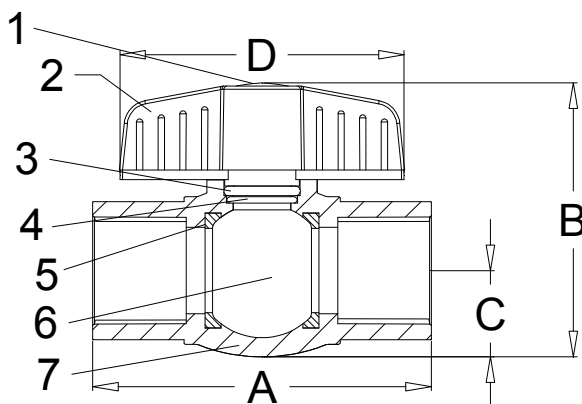

- NSF certified to NSF/ANSI 14
- NSF certified to NSF/ANSI 61 Annex G Lead-Free
- IPS
- NPT threads
- 150 psi @ 180°F
- Produced using virgin CPVC resins



No.	Part	Material
1	Cap	ABS
2	Handle	ABS
3	O-Ring	EPDM
4	O-Ring	EPDM
5	Seat	PTFE
6	Ball	PVC & ABS
7	Body	PVC

Size IN	Part Number	Weight LB	A IN	B IN	C IN	D IN
1/2	02939541G	0.2	3.16	2.46	0.71	2.74
3/4	02939541I	0.2	3.61	2.98	0.87	3.01
1	02939541K	0.4	4.19	3.39	1.06	3.53
1-1/4	02939541L	0.5	4.76	3.80	1.21	3.54
1-1/2	02939541M	0.8	5.13	4.32	1.46	4.42
2	02939541N	1.4	5.93	5.36	1.83	5.53

USA 800-766-0076

Fax 323-890-4456

www.smithcooper.com

Los Angeles, CA

Chicago, IL

Atlanta, GA

Vancouver, WA

Houston, TX

PVC BALL VALVE, SLIP



- NSF certified to NSF/ANSI 14
- NSF certified to NSF/ANSI 61 Annex G Lead-Free
- Schedule 40/80 PVC
- 150 psi @73°F
- Molded in place construction
- IPS

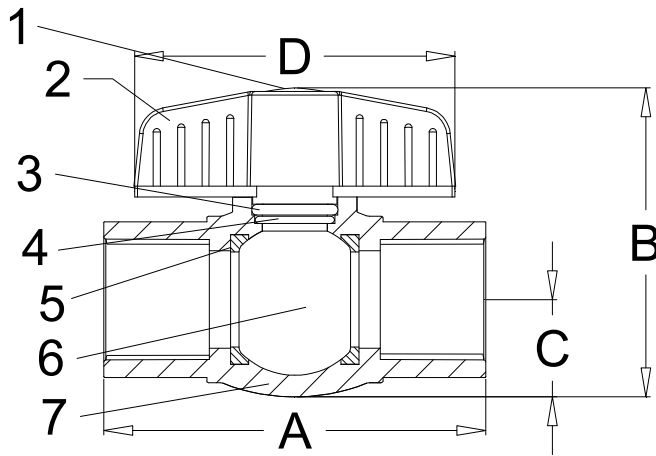

No.	Part	Material
1	Cap	ABS
2	Handle	ABS
3	O-Ring	EPDM
4	O-Ring	EPDM
5	Seat	PTFE
6	Ball	PVC & ABS
7	Body	PVC

Size IN	Part Number	Weight LB	A IN	B IN	C IN	D IN
1/2	02939542G	0.2	3.16	2.46	0.71	2.74
3/4	02939542I	0.2	3.61	2.98	0.87	3.01
1	02939542K	0.4	4.19	3.39	1.06	3.53
1-1/4	02939542L	0.5	4.76	3.80	1.21	3.54
1-1/2	02939542M	0.8	5.13	4.32	1.46	4.42
2	02939542N	1.4	5.93	5.36	1.83	5.53

USA 800-766-0076

Fax 323-890-4456

www.smithcooper.com

Los Angeles, CA

Chicago, IL

Atlanta, GA

Vancouver, WA

Houston, TX