



Series 0190103L

BRASS BOILER DRAIN, MIP



- California AB1953 lead-free approved
- Meets federal Safe Water Drinking Water Act, lead-free requirement
- 125 lb. WOG
- NPT x 3/4" NHT
- Cast brass
- CSA approved
- ANSI/NSF 61-8 approved (low lead)
- ISO 9001:2008 manufacturer

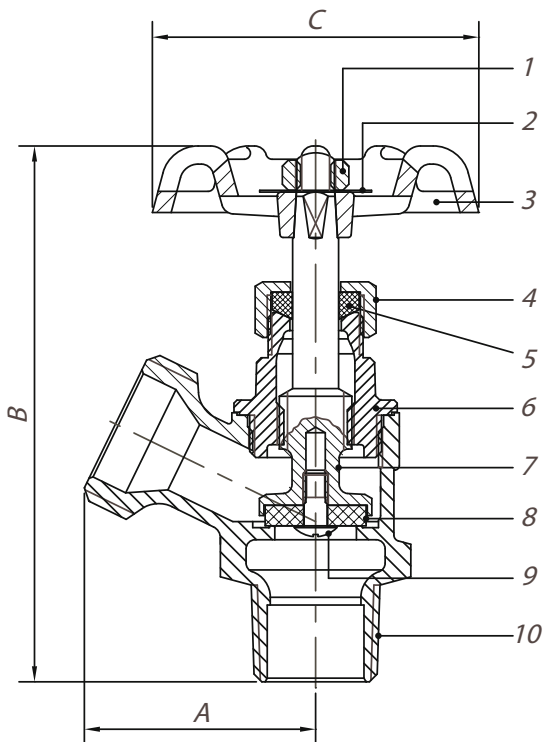

No.	Part	Material
1	Wheel Nut	Froged Steel ASTM-AISI-1010
2	Name Plate	Aluminium ASTM-B-209, Alloy 1100
3	Hand-Wheel	Cast Iron ASTM A-48, Class No. 35
4	Packing Nut	Brass ASTM B-16, C36000
5	Gland Packing	PTFE
6	Bonnet	Cast Brass ASTM B-584, C89550
7	Stem	Cast Brass ASTM B-584, C89550
8	Seat Packing	NBR
9	Seat Screw	Brass ASTM B-134, C27000
10	Body	Cast Brass ASTM B-134, C27000

USA 800-766-0076

Fax 323-890-4456

www.smithcooper.com

Los Angeles, CA

Chicago, IL

Atlanta, GA

Vancouver, WA

Houston, TX

Size IN	Part Number	Weight LB	A IN	B IN	C IN
1/2	0190103GL	0.5	1.57	3.58	2.13
3/4	0190103IL	0.5	1.57	3.70	2.13