

► **Code Number**

3396075

► **Description**

VBF-72-A Vacuum Breaker Trap Primer. The Sloan® VBF-72-A Vacuum Breaker Trap Primer provides for a constant water seal in floor drains. Maintaining a trap seal prevents objectionable sewer gases from escaping into the air. Each time the Sloan® Flushometer is activated, a small amount of water is diverted to the floor drain (piping from Trap Primer to floor drain not supplied by Sloan). The VBF-72-A uses a patented Water Deflector that carefully regulates the amount of water diverted to the drain. This makes the VBF-72-A specially suited for use with 1.28 gpf (4.8 Lpf) High Efficiency, 1.6 gpf (6.0 Lpf) Low Consumption and 3.5 gpf (13.2 Lpf) Water Saver Flushometers.

► **Specifications**

Vacuum Breaker Trap Primer for use with exposed Flushometers.

The VBF-72-A1 and VBF-72-A2 Trap Primers include:

- One Piece, Chrome Plated Flush Connection
- Water Deflector to control the amount of water diverted from the flush
- 3/8" Elbow and Flex-bend Tube connection from Vacuum Breaker to wall
- Diverter Wall Flange and Fittings
- Chrome Plated Wall Flange and Fitting to connect 1/2" NPT pipe

VBF-72-A1 Trap Primer also includes:

- Vacuum Breaker
- One-piece Bottom Hex Coupling Nut

The VBF-72-A can be supplied with the following Flushometer Models:

† Check with local codes for approval to use VBF-72-A1 Trap Primer with Model Numbers 110 and 111 Flushometers. Some codes require a minimum distance of 6" (153 mm) between the Critical Line of the Vacuum Breaker and the Trap Primer and the Trap Primer Outlet. In these cases specify the Model Numbers 113, 115 or 116.

When ordering a Sloan Flushometer with a Trap Primer, please specify the "TP" Variation; e.g., Model Number 110 TP.

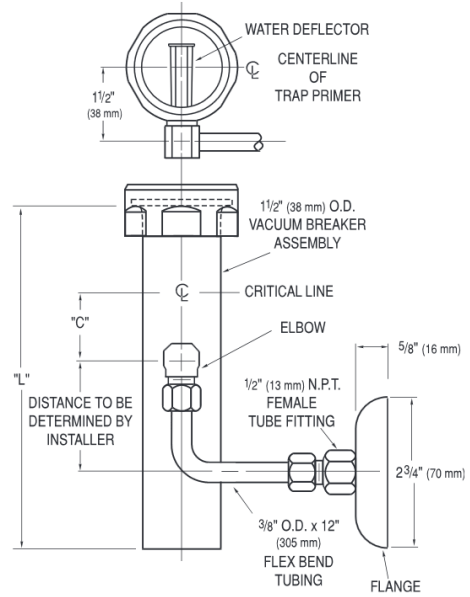

► **ROUGH-IN**

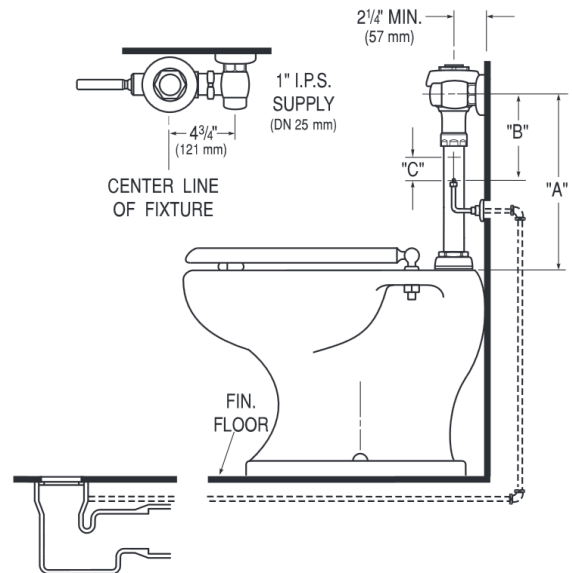

| Model Number | Flush Connection Length "L" | Centerline of Supply to Top of Bowl "A" | Centerline of Supply to Trap Primer Outlet "B" | Critical Line to Trap Primer Outlet "C" |
|--------------|-----------------------------|-----------------------------------------|------------------------------------------------|-----------------------------------------|
| 110/111 †    | 8 1/2" (216 mm)             | 11 1/2" (292 mm)                        | 7" (178 mm)                                    | 2 1/4" (57 mm)                          |
| 113          | 13" (330 mm)                | 16" (406 mm)                            | 11" (280 mm)                                   | 6 1/4" (159 mm)                         |
| 115          | 21" (533 mm)                | 24" (610 mm)                            | 11" (280 mm)                                   | 6 1/4" (159 mm)                         |
| 116          | 24" (610 mm)                | 27" (696 mm)                            | 11" (280 mm)                                   | 6 1/4" (159 mm)                         |

► **Compliance & Certifications**



Made In The  
**USA**

This space for Architect/Engineer Approval