

Optima® Dual-Flush and Single-Flush Side Mount Unit

Battery-powered, sensor-activated, retrofit unit for exposed, dual-flush and single-flush closet and single-flush urinal.

PARTS LIST

Item No.	Code No.	Part No.	Description
1.	3325506	EBV-505-A	Dual-Flush Sleeve Assembly
2.	3325507	EBV-570-A	Single-Flush Sleeve Assembly
3.	0372049	WES-46	DFSM Wall Plate
4.	3325509	EBV-576	GEM Adapter Kit for SFSM
5.	5325376	—	GEM Yellow Gasket (Pack of 5)
6.	—	—	—
7.	—	—	2.5 mm Hex Wrench for Battery Compartment
8.	0325380	EBV-545	Collar Wrench
9.	—	—	4 C-Cell Batteries (factory installed)
10.	3325204	EBV-1014-A	Battery Tray Assembly

* Refer to Royal Maintenance Guide for flushometer components.

Sensor Flushometers

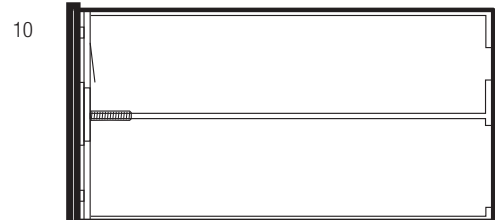
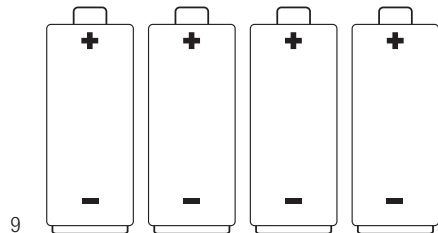
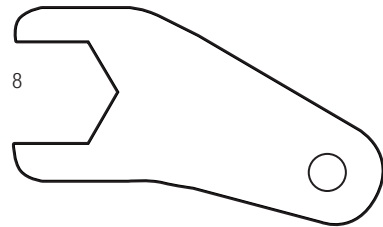
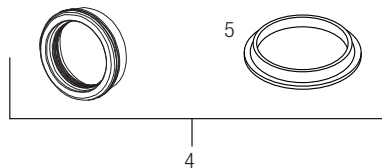
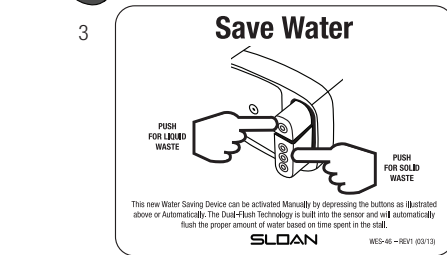
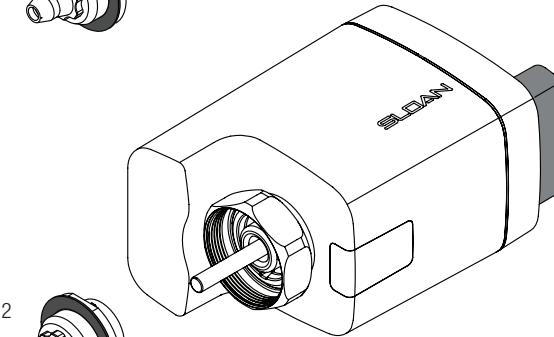
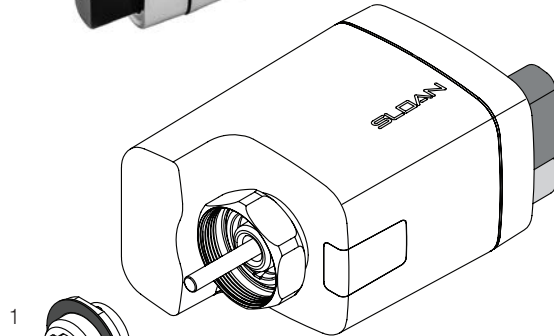

Optima® Dual-Flush and Single-Flush Side Mount Unit

BATTERY REPLACEMENT

Using the supplied battery compartment hex wrench, remove battery compartment from Side Mount unit.

Remove batteries from compartment tray.

Install 4 new C-cell batteries into compartment tray (note the position of batteries in tray), and reinstall compartment tray into the Side Mount unit.

The Side Mount unit comes preset from the factory. If special circumstances require adjustment of the activation distance, please contact Sloan.

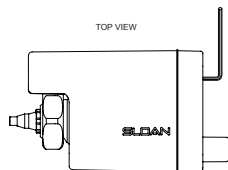

The Side Mount unit calibrates upon power up, GREEN and RED LEDs flash once. The unit will actuate a flush followed by 5 flashes of GREEN LED. The unit will then perform calibration, a 20 second sequence, where the GREEN LED flashes quickly. Finally the unit will start normal operation.

Manual flush button on Side Mount unit allows manual activation, when desired.

MODE CHANGE (SINGLE-FLUSH UNITS ONLY)

Units are preset at factory in water closet mode.

To change unit from water closet to urinal mode, complete the following:

Press and hold the True Mechanical Override (TMO) button for 20-30 seconds.

The unit will exhibit an LED flash pattern as follows:

- For approximately the first 10 seconds there will be no LED flashing
- For approximately seconds 10-20, both the RED and GREEN LEDs will produce short simultaneous flashes
- For approximately seconds 20-30, the GREEN LED will flash

Release the TMO button during the 20-30 seconds when both the RED and GREEN LEDs produce SHORT simultaneous flashes and remove non-permanent items from view of the sensor. The Side Mount unit will now be in urinal mode* and begin calibration.

To change back to closet mode, press and hold the TMO button for 30-40 seconds. Release when RED and GREEN LEDs produce short simultaneous flashes. The Side Mount unit will now be in close mode and begin calibration.

* Urinal mode provides a shorter sensor range and 1-2 second flush delay.

TROUBLESHOOTING GUIDE

1. RED LED continuously flashes when target is present.

The battery is low. Refer to battery replacement instructions.

2. RED LED flashes 4 times after a target has been present for 8 seconds. RED LED flashes once when a target is NOT present.

The battery is low. Refer to battery replacement instructions.

3. RED LED flashes continuously after calibration.

The unit has failed to calibrate. The optics window is obscured. Remove power, clean window and remove any objects (barrels, toolboxes, etc.) within close proximity of unit. Repeat power-up sequence (See BATTERY REPLACEMENT for power-up sequence). If unit fails, consult Sloan Technical Support.

CARE AND CLEANING OF CHROME AND SPECIAL FINISHES

DO NOT USE abrasive or chemical cleaners (including chlorine bleach) to clean side mount unit or flushometer that may dull the luster and attack the finish. Use **ONLY** mild soap and water, then wipe dry with clean cloth or towel.

While cleaning the bathroom tile, protect the side mount unit from any splattering of cleaner. Acids and cleaning fluids can discolor or remove chrome plating.

DO NOT USE abrasive or chemical cleaners (including chlorine bleach) to clean sensor window that may distort or ruin the sensor.

When assistance is required, please contact

Sloan Technical Support at: 1-888-SLOAN-14 (1-888-756-2614).