

# Rittal – The System.

Issue 5

Faster – better – worldwide.

## ► Data Centre Solutions



RACKS

POWER

COOLING

MONITORING

SECURITY

SERVICE & SUPPORT





# The simple route to the perfect data centre

Data centres are complex systems. Software, hardware and IT infrastructure must work together seamlessly to supply the user with energy and cost efficient, reliable IT services. The IT infrastructure alone demands a wide variety of specialists from each field including: climate control, power distribution and security.

“Rittal - The System”, minimises complexity and reduces interfaces through a complete, integrated solution. Superior IT performance is achieved through perfect coordination of the Rittal IT System modules: Racks, Power, Cooling, Security, Monitoring, Remote Management and containerised, turnkey solutions, all complimented by a comprehensive range of software and services.

*Data Centre Solutions* presents you with a complete overview of the Rittal IT System.

Peter Mellino  
Managing Director  
Rittal Australia and New Zealand



RACKS

POWER

COOLING

# Contents

## NETWORK ENCLOSURES & SERVER RACKS

TS IT Rack - Glazed Door	4
TS IT Rack - Vented Door	6
System Accessories	8
	10

## POWER DISTRIBUTION/ POWER BACKUP

The Rittal UPS Family	28
UPS PMC 12	30
UPS Accessories	31
UPS PMC 40	33
UPS PMC 120	35
UPS PMC 200	36
Horizontal & Vertical GPO Power Rails	38
PDUi - Power Distribution Unit	39
Power System Module (PSM)	42

## CLIMATE CONTROL

IT Roof Mounted Cooling Units	46
Water based Cooling Solutions	50
Refrigerant - Based Cooling Solutions	51
LCP - Liquid Cooling Package CW	53
Accessories for LCP CW/DX	55
Aisle Containment	59
IT Chillers	61
	62

## MONITORING

CMC III Monitoring Systems	65
CMC III Processing Unit/Compact	66
CMC III Sensors/Accessories	67
CMC III Processing Unit/Compact - System Overview	70
Door Control System	71
RiZone	74

## SECURITY SOLUTIONS

IT Security Solutions	76
IT Security Rooms	77
IT Security Safes	78
Level E Modular Safe	81
Level B Modular Safe	82
Level A Compact Safe	84
Compact Split Cooling Solutions for Modular Safes	86
Split Outdoor Cooling Solutions for Modular Safes	87
Split Outdoor Cooling Solutions with Inverter Technology	88
Fire Alarm & Extinguisher Systems	89
	90

## DATA CENTRE CONTAINERS

## SERVICE & SUPPORT

Engineering & Design	91
Rittal Global Service	92
	93
	94

## REFERENCES

## INDEX

## NOTES

95
96
97

# Data centres that are perfect in every detail!

A perfect IT environment provides the basis for perfect business. Rittal plans, builds and optimises data centres on your behalf, thereby making an effective and efficient contribution to your corporate success. We will advise, design and develop solutions that fit your business perfectly.

## The benefits to you:

- You benefit from the opportunities offered by a complete supplier.
- From the initial draft, through to the implementation phase and commissioning, you only deal with one point of contact.
- You have structure and clarity in your data centre project.
- All participants and all components are precisely coordinated with one another.
- Every detail contributes to ensure optimum overall performance capability of the system.

## “Rittal – The System. Faster – better – worldwide.”

We accompany you every step of the way, from analysis, to planning and implementation, through to safeguarding your requirements with our global service.

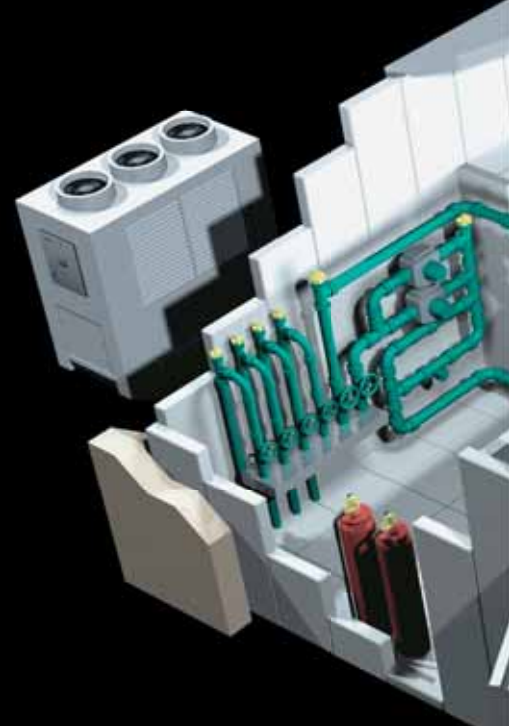

### All services from a single source

- Network enclosures and server racks
- Power distribution and backup
- Climate control
- Monitoring
- Security solutions
- Engineering & design
- Service & support

#### NETWORK ENCLOSURES/ SERVER RACKS



#### POWER DISTRIBUTION/ POWER BACKUP

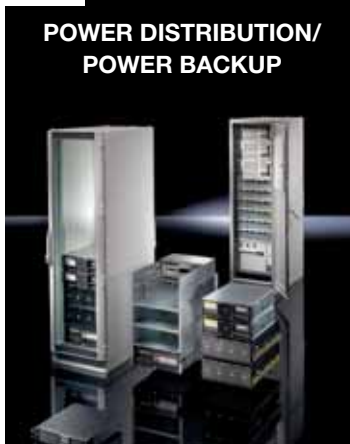

#### CLIMATE CONTROL



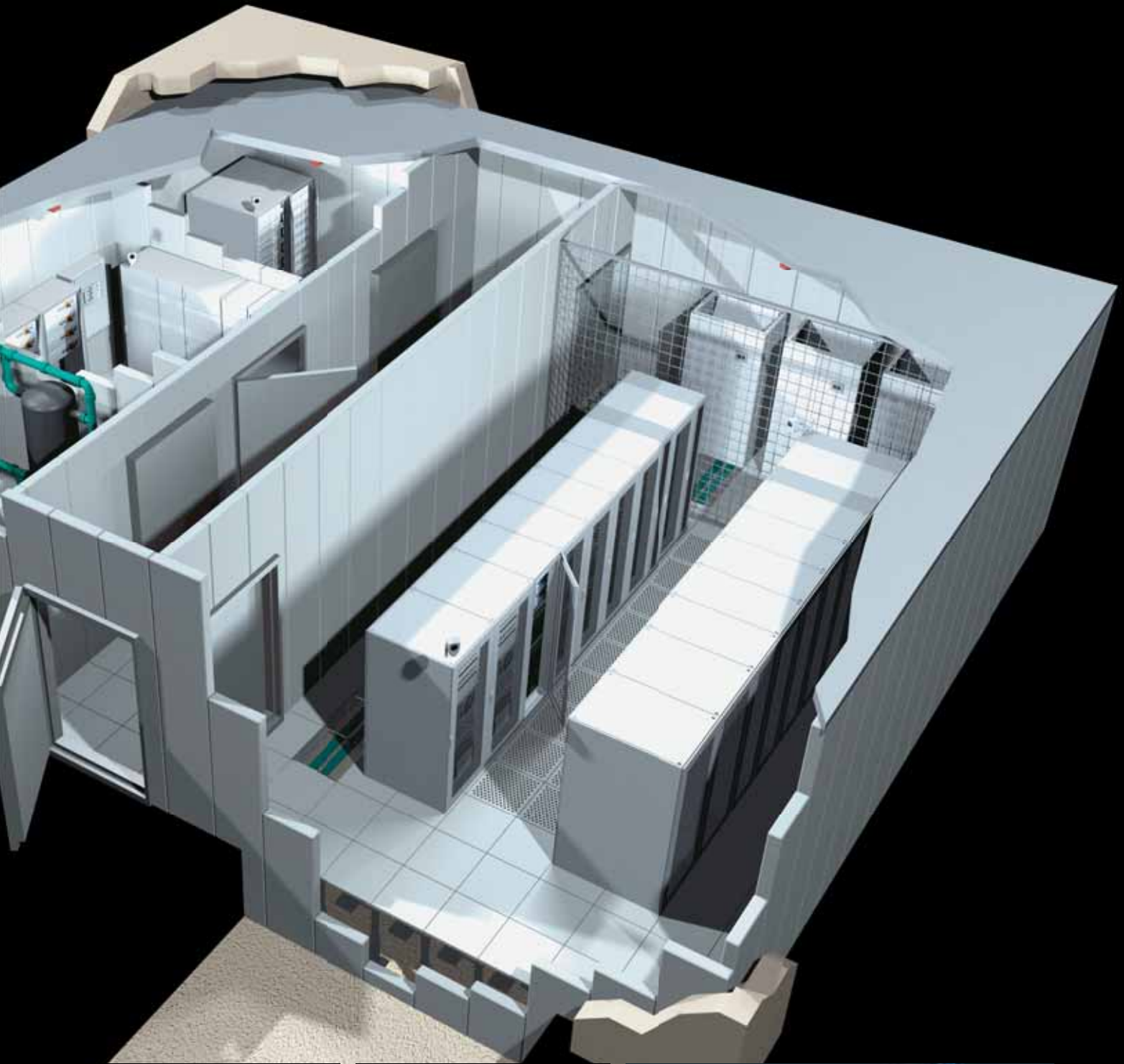

**SECURITY**

**MONITORING**

**SERVICE & SUPPORT**



**MONITORING**

**SECURITY**

**SERVICE & SUPPORT**



4

9

7

5

6

8

3

10

1

2

# The TS-IT rack. The benefits at a glance.

## **1 Individual configuration**

A basis for practically all network and server enclosure requirements

## **2 High load capacity and variable interior installation**

Load capacity up to 1,500 kg and tool-free adjustment of the 482.6 mm (19") mounting levels. Offset positioning facilitates alternative mounting widths (21", 23", 24" possible)

## **3 Tool-free installation**

System accessories with new, time-saving snap-in technology (for component shelves, cable ducts and more besides)

## **4 Intelligent cable management**

Multifunctional roof with cable entry down the sides for maximum convenience and unhindered air circulation for active components

## **5 Fast side panel assembly**

Divided side panels with quick fastenings, integrated locks and additional internal latching

## **6 Convincing door concept**

Glazed doors for high-performance server applications with liquid cooling or vented doors for room climate control

## **7 Divided rear doors**

Divided rear doors from a height of 1,800 mm for optimised space utilisation

## **8 Intelligent accessories**

New TS IT concept ensures fast and simple selection of the system accessories

## **9 Built-in added value for the 482.6 mm (19") system**

Direct, space-saving clip mounting of the new Rittal PDU busbar in the rear zero U space. Tool-free front-side integration of cable management and Dynamic Rack Control

## **10 Simple positioning**

Labelling of the height units and pitch pattern in the depth for simple determination of the 482.6 mm (19") level spacing



# TS-IT Glazed Door

**Material:**

- Sheet steel
- Glazed door: Single-pane safety glass, 3 mm

**Surface finish:**

- Enclosure frame, interior installation: Dipcoat-primed
- Doors and roof: Dipcoatprimed, powder-coated

**Colour:**

- Frame and enclosure panels: RAL 7035
- Interior installation: RAL 9005

**Supply includes:**

Product-specific supply scope, see table.

**Load capacity of the 482.6 mm (19") mounting level:**  
15,000 N

**Distance between levels as delivered:**

- Depth 800: 545 mm
- Depth 1000: 745 mm
- Depth 1200: 745 mm

**Approvals:**

UL/cUL

**Detailed drawings:**

Available on the Internet.



## With glazed door for rack climate control (Supply includes levelling feet & castors)

U	Packs of	24	24	38	42	42	Page
Width mm		800	800	800	800	800	
Height mm		1200	1200	1800	2000	2000	
Depth mm		800	1000	800	600	800	
Glazed aluminium door at the front (180°), with comfort handle for semi-cylinder and security lock 3524E	1	■	■	■	■	■	
Sheet steel door at the rear (180°), with comfort handle for semi-cylinder and security lock 3524E	1	■	■	-	-	-	
Sheet steel door at the rear (180°), vertically divided, with comfort handle for semi-cylinder and security lock 3524E	1	-	-	■	■	■	
482.6 mm (19") mounting level at the front and rear, on depth stays with quick-release fasteners, depth-variable	2	■	■	■	■	■	
Roof plate, multi-piece, removable, with side cable entry in the depth and covered cut-out for fan mounting plate	1	■	■	■	■ <sup>1)</sup>	■	
<b>Model No. DK</b>	1	XAU5503.120	XAU5504.120	XAU5505.120	XAU5506.120	XAU5507.120	

### Included with the supply, not pre-installed

Spacers for passive cooling	4	■	■	■	■	■	
Potential equalisation with central earthing point	1 set	■	■	■	■	■	
Multi-tooth screws M5, cage nuts M5, conductive	50	■	■	■	■	■	

### Accessories

Side panels, lockable	2-part	1	-	-	2 x 5501.000	2 x 5501.010	2 x 5501.020	10
	1-part	2	7824.128	7824.120	-	-	-	387 <sup>2)</sup>
Base Mount		2	5501.310	5501.320	5501.310	5501.300	5501.310	22
Gland plates, modular		See from page 23						
Fan mounting plate for TS IT including thermostat		1	5502.020	5502.020	5502.020	5502.010	5502.020	11
Air baffle plate		1 set	-	-	-	5501.815	5501.815	11
Cable tray		1	-	-	-	5502.120	5502.120	19
Cable duct		1	-	-	-	5502.105	5502.105	16
Component shelves		See from page 13						
Cable shunting ring		See page 15						
Cable management panel		See page 17						
Power distribution unit PDU		See from page 39						

U	Packs of	42	42	42	42	47	Page
Width mm		600	800	600	800	800	
Height mm		2000	2000	2000	2000	2200	
Depth mm		1000	1000	1200	1200	800	
Glazed aluminium door at the front (180°), with comfort handle for semi-cylinder and security lock 3524E	1	■	■	■	■	■	
Sheet steel door at the rear (180°), with comfort handle for semi-cylinder and security lock 3524E	1	■	■	■	■	■	
Sheet steel door at the rear (180°), vertically divided, with comfort handle for semi-cylinder and security lock 3524E	1	■	■	■	■	■	
482.6 mm (19") mounting level at the front and rear, on depth stays with quick-release fasteners, depth-variable	2	■	■	■	■	■	
Roof plate, multi-piece, removable, with side cable entry in the depth and covered cut-out for fan mounting plate	1	■	■	■	■	■	
<b>Model No. DK</b>	1	XAU5508.120	XAU5509.120	XAU5510.120	XAU5511.120	XAU5512.120	

### Included with the supply, not pre-installed

Spacers for passive cooling	4	■	■	■	■	■	
Potential equalisation with central earthing point	1 set	■	■	■	■	■	
Multi-tooth screws M5, cage nuts M5, conductive	50	■	■	■	■	■	

### Accessories

Side panels, 2-part	1	2 x 5501.030	2 x 5501.030	2 x 5501.040	2 x 5501.040	2 x 5501.050	10	
Base Mount	2	5501.320	5501.320	5501.350	5501.350	5501.310	22	
Gland plates, modular		See from page 23						
Fan mounting plate for TS IT including thermostat	1	5502.010	5502.020	5502.010	5502.020	5502.020	11	
Air baffle plate	1 set	5501.805	5501.815	5501.805	5501.815	5501.835	11	
Cable tray	1	5502.120	5502.120	5502.120	5502.120	5502.120	19	
Cable duct	1	-	5502.105	-	5502.105	5502.145	16	
Component shelves		See from page 13						
Slide rails		See from page 14						
Cable shunting ring		See page 15						
Cable management panel		See page 17						
Power distribution unit PDU		See from page 39						

■ Included with the supply.

<sup>1)</sup> Cable entry, rear.

<sup>2)</sup> See Catalogue 33



# TS-IT Vented Door

**Material:**

Sheet steel

**Surface finish:**

- Enclosure frame, interior installation: Dipcoat-primed
- Doors and roof: Dipcoat-primed, powder-coated

**Colour:**

- Frame and enclosure panels: RAL 7035
- Interior installation: RAL 9005

**Supply includes:**

Product-specific supply scope, see table.

**Load capacity of the**

**482.6 mm (19") mounting level:**  
15,000 N

**Distance between levels as delivered:**

745 mm

**Approvals:**

UL/cUL

**Detailed drawings:**

Available on the Internet.

## With vented door for room climate control (Supply includes levelling feet & castors)

U	Packs of	24	42	42	42	42	Page
Width mm		800	600	800	600	800	
Height mm		1200	2000	2000	2000	2000	
Depth mm		1000	1000	1000	1200	1200	
Sheet steel door, vented <sup>1)</sup> , at the front (180°), with comfort handle for semi-cylinder and security lock 3524 E	1	■	■	■	■	■	
Sheet steel door, vented <sup>1)</sup> , rear (180°), with comfort handle for semi-cylinder and security lock 3524 E	1	■	-	-	-	-	
Sheet steel door, vented <sup>1)</sup> , rear (180°), vertically divided, with comfort handle for semi-cylinder and security lock 3524 E	1	-	■	■	■	■	
482.6 mm (19") mounting level at the front and rear, on depth stays with quick-release fasteners, depth-variable	2	■	■	■	■	■	
Roof plate, multi-piece, removable, with side cable entry in the depth and covered cut-out for fan mounting plate	1	■	■	■	■	■	
<b>Model No. DK</b>	1	XAU5504.110	XAU5508.110	XAU5509.110	XAU5510.110	XAU5511.110	

### Included with the supply, not pre-installed

Spacers for passive cooling	4	■	■	■	■	■	
Potential equalisation with central earthing point	1 set	■	■	■	■	■	
Multi-tooth screws M5, cage nuts M5, conductive	50	■	■	■	■	■	

### Accessories

Side panels, lockable	2-part	1	-	2 x 5501.030	2 x 5501.030	2 x 5501.040	2 x 5501.040	10
	1-part	2	7824.120	-	-	-	-	387 <sup>2)</sup>
Base Mount		2	5501.320	5501.320	5501.320	5501.350	5501.350	22
Gland plates, modular		See from page 23						
Base/plinth		See from page 22						
Fan mounting plate for TS IT including thermostat		1	5502.020	5502.010	5502.020	5502.010	5502.020	30
Air baffle plate		1 set	-	5501.805	5501.815	5501.805	5501.815	30
Cable tray		1	-	5502.120	5502.120	5502.120	5502.120	38
Cable duct		1	-	-	5502.105	-	5502.105	35
Component shelves		See from page 13						
Slide rails		See from page 14						
Cable shunting ring		See page 15						
Cable management panel		See page 17						
Power distribution unit PDU		See from page 39						

U	Packs of	47	47	47	47	Page
Width mm		600	800	600	800	
Height mm		2200	2200	2200	2200	
Depth mm		1000	1000	1200	1200	
Sheet steel door, vented <sup>1)</sup> , at the front (180°), with comfort handle for semi-cylinder and security lock 3524 E	1	■	■	■	■	
Sheet steel door, vented <sup>1)</sup> , rear (180°), vertically divided, with comfort handle for semi-cylinder and security lock 3524 E	1	■	■	■	■	
482.6 mm (19") mounting level at the front and rear, on depth stays with quick-release fasteners, depth-variable	2	■	■	■	■	
Roof plate, multi-piece, removable, with side cable entry in the depth and covered cut-out for fan mounting plate	1	■	■	■	■	
<b>Model No. DK</b>	1	XAU5513.110	XAU5514.110	XAU5515.110	XAU5516.110	

### Included with the supply, not pre-installed

Spacers for passive cooling	4	■	■	■	■	
Potential equalisation with central earthing point	1 set	■	■	■	■	
Multi-tooth screws M5, cage nuts M5, conductive	50	■	■	■	■	

### Accessories

Side panels, 2-part	1	2 x 5501.060	2 x 5501.060	2 x 5501.070	2 x 5501.070	10
Base Mount	2	5501.320	5501.320	5501.350	5501.350	22
Gland plates, modular		See from page 23				
Base/plinth		See from page 22				
Fan mounting plate for TS IT including thermostat	1	5502.010	5502.020	5502.010	5502.020	11
Air baffle plate	1 set	5501.825	5501.835	5501.825	5501.835	11
Cable tray	1	5502.120	5502.120	5502.120	5502.120	19
Cable duct	1	-	5502.145	-	5502.145	16
Component shelves		See from page 13				
Slide rails		See from page 14				
Cable shunting ring		See page 15				
Cable management panel		See page 17				
Power distribution unit PDU		See from page 39				

■ Included with the supply.

<sup>1)</sup> Vented surface area approx. 85% perforated.

<sup>2)</sup> See Catalogue 33

# System Accessories

## Side panels/baying



### Side panel, divided

- Easy handling and tool-free assembly
- Quick-release fastener including security lock 3524 E
- Internal latch included (cannot be opened with a key)
- Lock with chassis, cable clamp rail may be top-mounted on the outer mounting level

**Material:**  
Sheet steel

**Surface finish:**  
Spray-finished

**Colour:**  
RAL 7035

- Supply includes:**
- 1 console
  - 1 pedestal
  - Earth conductor
  - Assembly parts

For enclosures		Packs of	Model No. DK
Height mm	Depth mm		
1800	800	1	5501.000
2000	600	1	5501.010
2000	800	1	5501.020
2000	1000	1	5501.030
2000	1200	1	5501.040
2200	800	1	5501.050
2200	1000	1	5501.060
2200	1200	1	5501.070



### Side panel, lockable

for TS

- Simply locate from above
- Lock via security lock no. 3524 E
- Earthing bolt with contact lug.

**Material:**  
Sheet steel, powder coated

**Colour:**  
RAL 7035

**Protection category:**  
NEMA 1/IP 20 to EN 60 529

- Supply includes:**
- 2 side panels each with 4 security locks no. 3524 E.

#### + Accessories:

For enclosures		Packs of	Model No. DK
Height mm	Depth mm		
1200	800	2	7824.128
1200	1000	2	7824.120

#### + Accessories:

Internal latch DK 7824.510, see Catalogue 33, page 388.

Other side panel sizes available. See CAT 33.

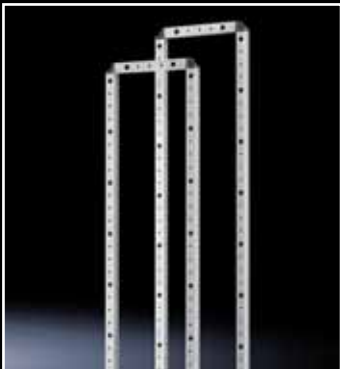

### Tubular door frame

for rear door, vertically divided, solid

**Material:**  
Sheet steel, powder coated

**Surface finish:**  
Zinc-plated

**Supply includes:**  
Assembly parts

For enclosures		Packs of	Model No. DK
Width mm	Height mm		
600	2000	1 set	5501.200
800	2000	1 set	5501.210

**Note:**

Required for use of the automatic door opener.



# System Accessories

## Ventilation/air partitioning

### Fan mounting plate

#### for TS IT

For active ventilation. For use in the cut-out integrated into the roof plate. The unit may optionally be extended with additional fans.

#### Technical specifications for one fan:

Fan expansion kit, D 7980.000, see Catalogue 33, page 404.

#### Technical specifications of thermostat:

- Rated operating voltage: 250 V
- Temperature range: +5 °C to +55 °C

#### Colour:

RAL 7035

#### Supply includes:

- Fan unit
- 2 fans
- 1 thermostat
- Open connection cable
- Assembly parts.

#### Note:

Connection via distributor box or country-specific connector.



#### Accessories:

Fan expansion kit 7980.000, see Catalogue 33, page 222.

W x D mm	Number of pre-wired fans	Possible number of fans	Model No. DK
800 x 600, 600 x 1000, 600 x 1200	2	3	5502.010
800 x 800, 800 x 1000, 800 x 1200	2	6	5502.020

### Air baffle plate

#### for TS IT

- To separate the hot/cold zones within an enclosure with aisle containment or when using an LCP system
- With all-round brush strip for collision-free shielding with installed bar systems on the outer mounting level
- For width 800 mm, 6 U blanking panel additionally included

#### Material:

Sheet steel, plastic UL 94 V0

#### Surface finish:

Spray-finished

#### Supply includes:

Assembly parts.

Width x Height mm	Packs of	Model No. DK
600 x 2000	1 set	5501.805
800 x 2000	1 set	5501.815
600 x 2200	1 set	5501.825
800 x 2200	1 set	5501.835

### Cover, magnetic

For optionally covering the front system punchings in the event of complete air blocking of the front, or in the absence of installed cable fingers or dynamic rack control strip.

Length m	Packs of	Model No. DK
5	1	5501.895



# System Accessories

## Ventilation/air partitioning



### Blanking panel, 482.6 mm (19')

As an extension cover or for population as required.

**Material:**  
Sheet steel

**Colour:**  
RAL 9005

U	Installation height mm	Packs of	Model No. DK
1	44	2	7151.005
2	88	2	7152.005
3	132.5	2	7153.005 <sup>1)</sup>
6	266	2	7156.005 <sup>1)</sup>

<sup>1)</sup> Extended delivery times.



### Blanking panel, 1 U

#### Tool-free attachment, 482.6 mm (19')

The blanking panel is used to seal unused areas within the 482.6 mm (19') mounting level. Quick tool-free attachment means that it is easily integrated anywhere, and can also be removed again if necessary. The consistent use of blanking panels ensures targeted air routing in partially configured racks.

**Material:**  
Plastic, ABS

**Colour:**  
RAL 9005

**Fire protection:**  
Self-extinguishing to UL 94-V0, non-halogen-free

**Supply includes:**  
10 blanking panels with integral quick-fastening.

Packs of	Model No. DK
10	7151.105



### Modular tooless blanking panel

- 6RU sheet
- Snap off feature allows between 1 to 6 RU's
- Tooless mounting

**Material:**  
Plastic

**Colour:**  
RAL 9005

Height mm	Model No. DK
6RU	XAU7151.105



### Baying connectors, external

#### for TS/TS

For mounting on the vertical enclosure sections. Simply position on the outside and screw-fasten either from the inside or outside.

**Material:**  
Sheet steel

**Surface finish:**  
Zinc-plated

**Supply includes:**  
Assembly parts.

Packs of	Model No. TS
6	8800.490

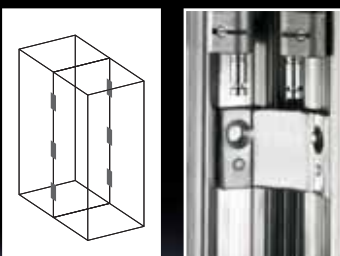

# Toolless System Accessories

## Component shelves/slide rails

### Component shelf, 2 U, static installation

**482.6 mm (19')**

For mounting between 482.6 mm (19') mounting angles.

**Load capacity:**

25 kg surface load, static

**Material:**

Sheet steel

**Surface finish:**

Spray-finished

**Colour:**

RAL 9005

**Supply includes:**

Assembly parts.

Component shelf depth mm	Packs of	Model No. DK
250	1 set	5501.615
400	1 set	5501.625



### Component shelf, static installation

**482.6 mm (19') depth-variable**

for TS IT, DK-TS

(L-shaped mounting angles,

**482.6 mm (19') mounting frame)**

For static installation between two 482.6 mm (19') mounting levels.

- Depth-variable to adapt to individual distances between levels
- Tool-free, time-saving one-man assembly

**Material:**

Sheet steel

**Surface finish:**

Spray-finished

**Colour:**

RAL 9005

**Supply includes:**

Assembly parts.

Distance between levels mm	Load capacity, static kg	Height U	Packs of	Model No. DK
400 - 600	50	½	1 set	5501.655
600 - 900	50	½	1 set	5501.665
400 - 600	100	1	1 set	5501.695
600 - 900	100	1	1 set	5501.705



### Component shelf, pull-out

**482.6 mm (19')**

for TS IT, DK-TS

(L-shaped mounting angles,

**482.6 mm (19') mounting frame)**

For mounting between two 482.6 mm (19') mounting angles.

- Depth-variable to adapt to individual distances between levels
- Tool-free, time-saving one-man assembly from the enclosure front
- Self-locking
- Fully extendible

**Material:**

Sheet steel

**Surface finish:**

Spray-finished

**Colour:**

RAL 9005

**Supply includes:**

- Installation kit
- Telescopic slide with mounting kit
- Assembly parts

Distance between levels mm	Load capacity, static kg	Height U	Depth mm	Packs of	Model No. DK
400 - 600	50	½	500	1 set	5501.675
600 - 900	50	½	700	1 set	5501.685
400 - 600	100	1	500	1 set	5501.715
600 - 900	100	1	700	1 set	5501.725



# System Accessories

## Component shelves/slide rails

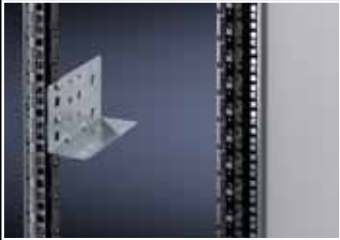

### Slide rails, static installation

#### for TS IT

For mounting between 482.6 mm (19") mounting angles.

- System punchings for mounting accessories and cooling active components

#### Technical specifications:

Load capacity: 30 kg, static

#### Material:

Sheet steel

#### Surface finish:

Zinc-plated

#### Supply includes:

Assembly parts.

U	Length mm	Packs of	Model No. DK
2	450	2	5501.400

### Slide rails, static installation

#### for TS IT

For mounting between a front and a rear pair of mounting angles.

- To support heavy installed equipment
- Side system punchings for mounting accessories and cooling components that expel to the side
- Simply locate into the system punchings of the TS IT

#### Technical specifications:

Load capacity: 80 kg, static

#### Material:

Sheet steel

#### Surface finish:

Zinc-plated

#### Supply includes:

Assembly parts.

U	482.6 mm (19") distance between levels mm	Packs of	Model No. DK
1	345	2	5501.410
1	445	2	5501.420
1	545	2	5501.430
1	645	2	5501.440
1	745	2	5501.450

### Depth-variable slide rails

#### 482.6 mm (19")

#### for TS IT, DK-TS

#### (L-shaped mounting angles, 482.6 mm (19") mounting frame)

For mounting between a front and a rear pair of mounting angles.

- To support heavy installed equipment
- To adapt to individual distances between levels
- Tool-free, time-saving one-man assembly from the enclosure front
- All three mounting holes in the EIA system punchings are available for screw-fastening the equipment

#### Material:

Sheet steel

#### Surface finish:

Zinc-plated

#### Supply includes:

Assembly parts.

482.6 mm (19") distance between levels mm	Load capacity kg	Packs of	Model No. DK
400 - 600	80	2	5501.460
600 - 900	150	2	5501.480



# System Accessories

## Cable management/cable clamping

### Cable manager

- For system-compatible cable deflection while complying with minimal bending radii and to accommodate surplus cables and excess length. The elements may optionally be used individually or in combination for cable routing. They may be combined into semi-circular or circular elements.
- Suitable for use on corners and edges to allow protected cable routing around them.
- Mounting clips for use above the arc hold the routed cables back within the elements. The elements are also bayable in an axial direction to allow U-based cable routing to the mounting level, or channelling of the cable sections.

**Material:**  
Plastic, UL 94-V0

**Colour:**  
RAL 9005

**Supply includes:**  
Mounting clips and assembly parts.

Packs of	Model No. DK
20	5502.405

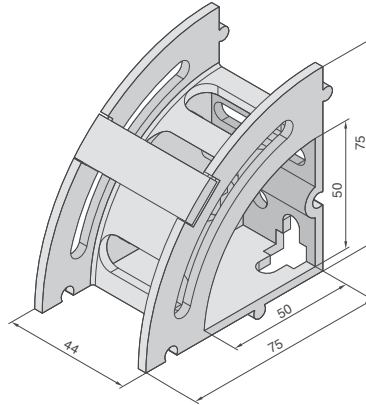

### Cable shunting ring

For flexible, system-compatible cable routing at the side of the 482.6 mm (19") mounting frame or on 482.6 mm (19") mounting angles.

**Material:**  
Sheet steel, zinc-plated

**Supply includes:**  
Mounting accessories.

Dimensions mm	Packs of	Model No. DK
125 x 65	10	7111.000
125 x 85	10	7111.900
85 x 43	10	7112.000



### Shunting ring

To accommodate large quantities of cables. Shunting ring for side attachment to 482.6 mm (19") sections and mounting frames in 800 mm wide network enclosures.

The ring is asymmetrically attached to create approx. 110 mm free space in front of the 482.6 mm (19") level. This allows effective management of even large quantities of cables.

**Material:**  
Round steel, zinc-plated

**Supply includes:**  
Assembly parts.

Dimensions mm	Packs of	Model No. DK
330 x 90/70	4	7220.600



# System Accessories

## Cable management/cable clamping



### Cable routing bars

For structured routing of entire cable bundles, the cable routing bars may be secured to a variety of different positions inside the enclosure.

**Material:**

- Support: Sheet steel
- Cable routing bars, connection combs: Plastic

**Colour:**  
RAL 9005

**Supply includes:**

- Cable routing bars
- Connection combs



### 482.6 mm (19") attachment

For horizontal cable routing within the distributor level.

Thanks to their open mounting holes, they can also be retrospectively slotted onto the 482.6 mm (19") system punchings of the mounting level at any time and secured with the existing mounting screws of the installed components.

U	No. of connection combs	Packs of	Model No. DK
4	2	4	7111.224
1	5	10	7111.214



### All-round attachment for universal use

For vertical and horizontal cable routing inside the enclosure or within the distributor level.

U	No. of connection combs	Packs of	Model No. DK
4	2	4	7111.222
1	5	10	7111.212



### Vertical cable duct

for TS IT, DK-TS, TE

- High packing density due to U-based cable routing
- Removable duct cover hinged on both sides
- Optional cable holders may be used (DK 7827.330, see Catalogue 33, page 728)
- Suitable for back-to-back baying
- Simple assembly with tool-free quick-release fastening
- Alternatively suitable for screw-fastening

For enclosure height mm	Packs of	Model No. DK
2000 / 42RU	1	5502.105
2200 / 47RU	1	5502.145

**Material:**

Sheet steel, plastic UL 94 V0

**Colour:**

RAL 9005

**Supply includes:**

Cover and assembly parts.



# System Accessories

## Cable management/cable clamping

### Cable finger 6 U

for TS IT

- For U-based cable routing
- Simple, tool-free assembly
- Cable routing possible in conjunction with air baffle plates
- 4 RU EA

**Material:**

Plastic, UL 94-V0

**Colour:**

RAL 9005

Packs of	Model No. DK
14	5502.115

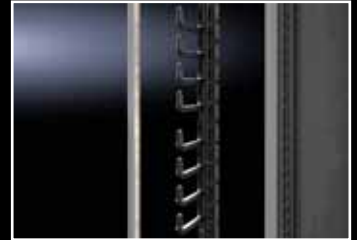
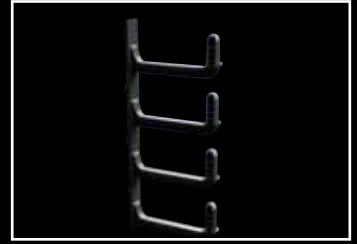

### Cable management panel

482.6 mm (19')

For horizontal management of the patch cables, with 5 cable shunting rings.

**Material:**

- Panel: Sheet steel
- Ring: Steel

**Surface finish:**

Ring: Zinc-plated

**Colour:**

Panel: RAL 9005

U	Ring Size mm	Packs of	Model No. DK
1	43 x 55	1	5502.205
1	43 x 105	1	7257.005
2	85 x 125	1	7257.105

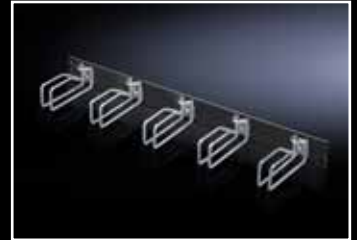

### Cable management panel with cable routing bars

482.6 mm (19')

For horizontal management of the patch cables with cable routing bars. Opening the individual cable routing bars allows user-friendly modification and extension of the cabling.

**Material:**

- Panel: Sheet steel, spray finished
- Cable routing bars: Plastic

**Colour:**

- Panel: RAL 9005
- Cable routing bars: Black

U	Bar depth mm	No. of bars/U	Packs of	Model No. DK
1	approx 80	5	1	5502.225



# System Accessories

## Cable management/cable clamping



### Cable management panel, 2 U 482.6 mm (19')

The cable routing chamber has cut-outs from above, into which the patch cables can be inserted. The cable management panel is equipped with a flap and quick-release fasteners at the front, for optimum access to the cables. From the rear, the cables can be inserted via a cut-out with brush strips. With accommodation facility for cable clamp straps DK 7610.000 or DK 7611.000.

**Material:**  
Sheet steel

**Colour:**  
RAL 9005

U	Depth mm	Packs of	Model No. DK
2	85	1	5502.235

**+ Accessories:**

Cable clamp straps, see Catalogue 33, page 535.

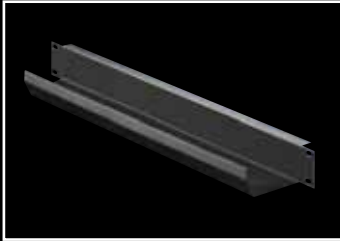

### Cable routing channel

482.6 mm (19')

To hold the patching cables.

**Material:**  
Sheet steel

**Colour:**  
RAL 9005

U	Depth mm	Packs of	Model No. DK
1	85	1	5502.245



### Cable entry panel

482.6 mm (19')

Cut-out 390 x 40 mm (2 U) or 390 x 20 mm (1 U) with brush insert. With accommodation facility for cable clamp straps DK 7610.000 or DK 7611.000.

**Material:**  
Sheet steel

**Colour:**  
RAL 9005

U	Packs of	Model No. DK
1	1	5502.225
2	1	5502.265

**+ Accessories:**

Cable clamp straps, see Catalogue 33, page 535.

# System Accessories

## Cable management/cable clamping

### System supports for cable routes

#### for TS

The depth-variable support system may be attached to all 800 – 1200 mm deep TS enclosures with external screw-fastening of the roof plate. The integral system punchings, for screws or cage nuts, support the attachment of most common cable route systems.

- May be combined with TS IT fan mounting plate
- In combination with punched rail, suitable for accommodating additional cable guide rails or pipelines.

Packs of	Model No. DK
2	7831.472

#### + Accessories:

- Metal multi-tooth screws 5.5 x 13 mm, SZ 2486.500.
- Cage nuts M6, TS 8800.340, see Catalogue 33, page 477.

**Material:**  
Sheet steel

**Surface finish:**  
Powder-coated

**Colour:**  
RAL 7035



### Cable tray

#### for TS

- For cable clamping and routing with network and server applications
- Mounting across the entire depth with 800 mm width, mounting only behind the second 482.6 mm (19") pair of mounting angles with 600 mm width
- Tool-free, fast assembly
- Alternatively suitable for screw-fastening
- Multi-functional punchings for cable management accessories

**Material:**  
Sheet steel

**Colour:**  
RAL 9005

Height mm	Packs of	Model No. DK
2000 - 2200	1	5502.120

#### + Accessories:

- Cable ties, nylon loops, see page 40/41.
- Shunting rings, see page 34.
- Cable routing bars, see page 35.



### Cable tray

**Material:**  
Sheet steel

**Surface finish:**  
Powder-coated

**Colour:**  
RAL 7035 (Grey)  
or  
RAL 905 (Black)

#### Grey

Height mm	Width mm	Model No. DK
24	100	XAUCT24100
42	100	XAUCT42100
42	300	XAUCT43000
47	100	XAUCT47100
47	300	XAUCT47300

#### Black

Height mm	Width mm	Model No. DK
24	100	XAUCT24100B
42	100	XAUCT42100B
42	300	XAUCT43000B
47	100	XAUCT47100B
47	300	XAUCT47300B

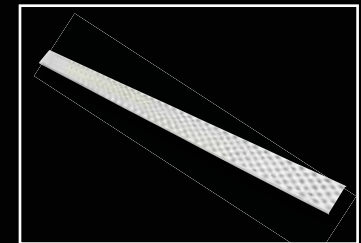

### Cage nuts

- Each fastener kit consists of a M6 cage nut, screw and nylon washer
- Available in black

Packs of	Model No. DK
50	XAUCNKIT50

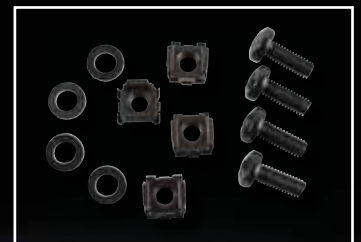

# System Accessories

## Cable management/cable clamping



### Nylon loop

With the nylon loop, secured cables are easily released, allowing individual cables to be added or removed. Ideal for sensitive data cables (fibreoptic/Cu), as it avoids indentations on the cable sheathing. In addition, the nylon loop may be screw-fastened to the round system punchings or attached using a quick-release fastener.

Width mm	Length mm	Max. cable diameter mm	Packs of	Model No. DK
20	130	30	10	<b>7072.220</b>
20	200	50	10	<b>7072.230</b>
20	300	90	10	<b>7072.240</b>

**Colour:**  
Black

**Supply includes:**  
Quick-release fasteners.



### Nylon tape

For tidy cable routing. Supplied on a reel for cutting to the required length.

Width mm	Length mm	Packs of	Model No. IN
5000	16	1	<b>2203.400</b>

Unlike cable ties, nylon tape

- protects the cable sheathing
- is easily reopened and
- is reusable



### Nylon tape supports

- For simple, fast cable attachment
- Tool-free mounting in the system punchings with 10.5 x 12.5 mm, with a quarter rotation
- Direct use on the horizontal TS section, on the support strips and mounting angles of the 482.6 mm (19") interior installation on the cable route or on punched sections with mounting flanges.
- Length of nylon tape: 400 mm

Packs of	Model No. DK
10	<b>5502.155</b>

**Material:**  
Plastic

**Supply includes:**  
10 supports including nylon tape.



# System Accessories

## Miscellaneous

### Earth rail, vertical

#### for TS

Easily fitted to the 25 mm DIN pitch pattern of distributors or to the 482.6 mm (19") mounting angles. The supplied earth conductors facilitate star earthing of the cable clamp straps in the patch panels.

The earth terminals are fully adjustable.

Current carrying capacity of rail approx. 200 A.

#### Supply includes:

- Earth rail made from E-Cu 57 to DIN 12 163, DIN EN 13 601, 15 x 5 mm
- 16 conductor connection clamps 2.5 – 16 mm<sup>2</sup>
- 15 earthing leads 6 mm<sup>2</sup>, L = 500 mm
- Assembly parts.

For enclosure height mm	Length mm	Packs of	Model No. DK
1200	1000	1 set	<b>7543.000</b>
1800	1600	1 set	<b>7546.000</b>
2000	1800	1 set	<b>7547.000</b>
2200	2000	1 set	<b>7548.000</b>

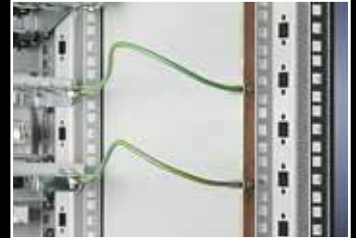

### Drawer, 2 U, 3 U

#### for mounting between two 482.6 mm (19") mounting levels

For front attachment to mounting angles, 482.6 mm (19"). With cover and telescopic slides to accommodate assignment lists, operating manuals and small parts. The small version of the 2 U variant is also suitable for mounting inside a swing frame.

#### Material:

Sheet steel

#### Colour:

RAL 9005

#### Supply includes:

Fully assembled, including assembly parts.

Height	Clearance openings		Installation depth mm	Packs of	Model No. DK
	Width mm	Height mm			
2 U	411	419	427	1	<b>5502.305</b>
3 U	411	419	427	1	<b>5502.325</b>

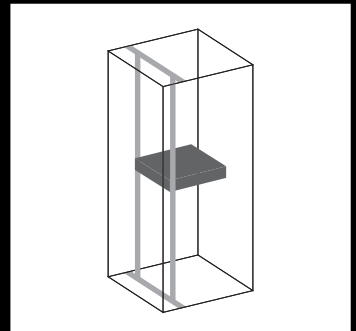

# System Accessories

## Base



### Base mounting bracket

for TS, SE, TP universal console

For anchoring the enclosure at any position of the base frame, particularly in cases where the existing holes in the frame or base tray cannot be used due to the installed equipment or because the substructure prevents them from being used.

**Material:**  
Sheet steel

**Surface finish:**  
Zinc-plated

Packs of	Model No. TS
4	8800.210

**Note:**  
Additional holes in the base are required for mounting.

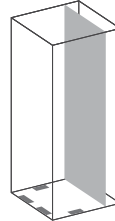

### Castor kit

for TS

Ground clearance: approx. 40 mm.

**Permissible static load:**  
750 kg per enclosure

**Supply includes:**  
1 set =  
4 castors (2 steerable) including assembly parts.

Packs of	Model No. DK
1 set	7825.900

**Note:**  
Cannot be used in conjunction with gland plates or base mounts.  
For 800 mm wide enclosures with 482.6 mm (19") mounting frame, special installation dimensions must be observed (see drawing).

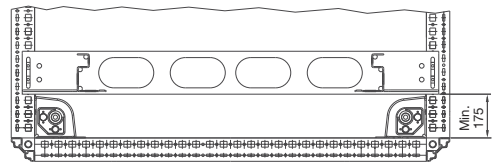

### Levelling feet

18 – 63 mm high, with hex socket

for baying system TS 8

To compensate for floor irregularities. Particularly in confined spaces, adjustments can be made quickly and easily from the enclosure interior.

Mounting thread: M12  
Hex socket: 6 mm  
Thread length: 60 mm

Max. admissible static load:  
300 kg per levelling foot.

Packs of	Model No. DK
4	7493.100

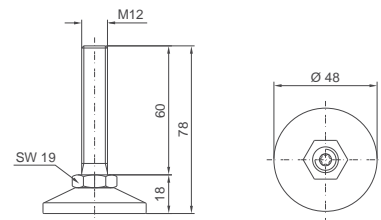

### Base mount

for TS

To accommodate gland plate modules.  
– Tool-free mounting or screw-fastening  
– Easily retrofitted and combined with stabiliser

**Material:**  
Sheet steel

**Surface finish:**  
Spray-finished

**Colour:**  
RAL 7035

**Supply includes:**  
2 mounting rails including assembly parts.

For enclosure depth mm	Packs of	Model No. DK
600	2	5501.300
800	2	5501.310
1000	2	5501.320
1200	2	5501.350



# System Accessories

## Base



### Gland plate

#### for TS IT

Potential equalisation is provided via assembly components and earthing points.

- Gland plate set  
To conceal the entire base opening.
- Gland plate modules  
Select suitable modules depending on the application.

**Material:**  
Sheet steel

**Surface finish:**  
Zinc-plated

**Supply includes:**  
Assembly parts.

**+ Accessories:**

Clips for gland plates,  
see Catalogue 33, page 377.

### For enclosure depth 600 mm

A Gland plate set	Packs of	Required packs of	For enclosure width mm	
			600	800
			Model No. DK	
Gland plate, solid, with sliding panel, multi-piece	1 set	1	-	5502.510

Gland plate modules	Packs of	Required packs of	For enclosure width mm	
			600	800
			Model No. DK	

B 1 module plate as selected	Model No. DK				
Gland plate, depth 150 mm	1	1	5001.218	5001.219	
Sliding panel, depth 150 mm	1	1	5001.239	5001.240	
Module plate, depth 237.5 mm	1	1	Vented with airflow regulator	7825.366	7825.386
			Cable entry with brush strip	7825.361	7825.381
			Vented	7825.360	7825.380
			Cable entry with brush strip, super-airtight	7825.367	7825.387
			Cable entry, side	-	7825.388

C Cable entry, rear or front	Model No. DK			
Gland plate, depth 100 mm	1	2	5001.214	5001.215
Sliding panel, depth 150 mm	1	2	5001.239	5001.240
Self-adhesive foam cable clamp strip	3 m	1	2573.000	2573.000

D Cable entry, centre	Model No. DK			
Gland plate, depth 100 mm	1	2	5001.214	5001.215
Sliding panel, depth 150 mm	1	2	5001.239	5001.240
Section for cable entry, centre	1 set	1	8802.060	8802.080

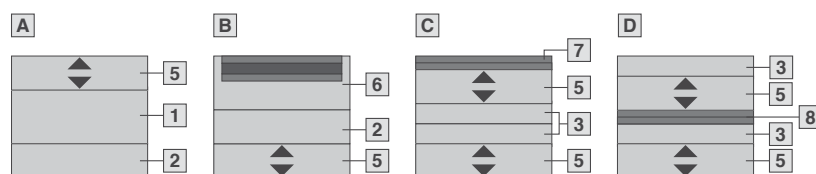

- 1 Gland plate, depth 250 mm
- 2 Gland plate, depth 150 mm
- 3 Gland plate, depth 100 mm
- 4 Gland plate, depth 50 mm
- 5 Sliding panel, depth 150 mm
- 6 Module plate, depth 237.5 mm
- 7 Self-adhesive foam cable clamp strip
- 8 Section for cable entry, centre

**! Also required:**

Base mount, see page 22.

**Note:**

Total installation depth 512 mm

# System Accessories

## Base

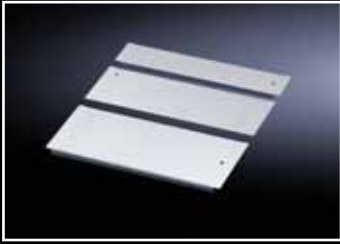

### For enclosure depth 800 mm

A Gland plate set	Packs of	Required packs of	For enclosure width mm	
			600	800
Model No. DK				
Gland plate, solid, with sliding panel, multi-piece	1 set	1	-	5502.530

Gland plate modules	Packs of	Required packs of	For enclosure width mm	
			600	800

B 1 module plate as selected			Model No. DK		
Gland plate, depth 250 mm	1	1	5001.222	5001.223	
Gland plate, depth 100 mm	1	1	5001.214	5001.215	
Sliding panel, depth 150 mm	1	1	5001.239	5001.240	
Module plate, depth 237.5 mm	1	1	Vented with airflow regulator	7825.366	7825.386
			Cable entry with brush strip	7825.361	7825.381
			Vented	7825.360	7825.380
			Cable entry with brush strip, super-airtight	7825.367	7825.387
			Cable entry, side	-	7825.388

C 2 module plates as selected			Model No. DK		
Gland plate, depth 100 mm	1	1	5001.218	5001.219	
Sliding panel, depth 150 mm	1	1	5001.239	5001.240	
Module plate, depth 237.5 mm	1	2	Vented with airflow regulator	7825.366	7825.386
			Cable entry with brush strip	7825.361	7825.381
			Vented	7825.360	7825.380
			Cable entry with brush strip, super-airtight	7825.367	7825.387
			Cable entry, side	-	7825.388

D Cable entry, rear or front			Model No. DK	
Gland plate, depth 250 mm	1	1	5001.222	5001.223
Gland plate, depth 150 mm	1	1	5001.218	5001.219
Sliding panel, depth 150 mm	1	2	5001.239	5001.240
Self-adhesive foam cable clamp strip	3 m	1	2573.000	2573.000

E Cable entry, centre			Model No. DK	
Gland plate, depth 250 mm	1	1	5001.222	5001.223
Gland plate, depth 150 mm	1	1	5001.218	5001.219
Sliding panel, depth 150 mm	1	2	5001.239	5001.240
Section for cable entry, centre	1 set	1	2573.000	2573.000

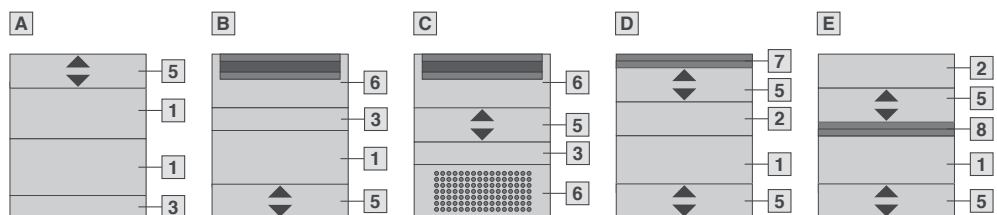

- 1 Gland plate, depth 250 mm
- 2 Gland plate, depth 150 mm
- 3 Gland plate, depth 100 mm
- 4 Gland plate, depth 50 mm
- 5 Sliding panel, depth 150 mm
- 6 Module plate, depth 237.5 mm
- 7 Self-adhesive foam cable clamp strip
- 8 Section for cable entry, centre

**!** Also required:

Base mount, see page 22.

**Note:**

Total installation depth 712 mm

# System Accessories

## Base



### For enclosure depth 1000 mm

A Gland plate set	Packs of	Required packs of	For enclosure width mm	
			600	800
			Model No. DK	
Gland plate, solid, with sliding panel, multi-piece	1 set	1	5502.540	5502.550

Gland plate modules	Packs of	Required packs of	For enclosure width mm	
			600	800

B 1 module plate as selected			Model No. DK		
Gland plate, depth 250 mm	1	2	5001.222	5001.223	
Gland plate, depth 50 mm	1	1	5001.210	5001.211	
Sliding panel, depth 150 mm	1	1	5001.239	5001.240	
Module plate, depth 237.5 mm	1	1	Vented with airflow regulator	7825.366	7825.386
			Cable entry with brush strip	7825.361	7825.381
			Vented	7825.360	7825.380
			Cable entry with brush strip, super-airtight	7825.367	7825.387
			Cable entry, side	-	7825.388

C 2 module plates as selected			Model No. DK		
Gland plate, depth 250 mm	1	1	5001.222	5001.223	
Gland plate, depth 100 mm	1	1	5001.214	5001.215	
Sliding panel, depth 150 mm	1	1	5001.239	5001.240	
Module plate, depth 237.5 mm	1	2	Vented with airflow regulator	7825.366	7825.386
			Cable entry with brush strip	7825.361	7825.381
			Vented	7825.360	7825.380
			Cable entry with brush strip, super-airtight	7825.367	7825.387
			Cable entry, side	-	7825.388

D Cable entry, rear or front			Model No. DK	
Gland plate, depth 250 mm	1	2	5001.222	5001.223
Gland plate, depth 100 mm	1	1	5001.214	5001.215
Sliding panel, depth 150 mm	1	2	5001.239	5001.240
Self-adhesive foam cable clamp strip	3 m	1	2573.000	2573.000

E Cable entry, centre			Model No. DK	
Gland plate, depth 250 mm	1	2	5001.222	5001.223
Gland plate, depth 100 mm	1	1	5001.214	5001.215
Sliding panel, depth 150 mm	1	2	5001.239	5001.240
Section for cable entry, centre	1 set	1	2573.000	2573.000

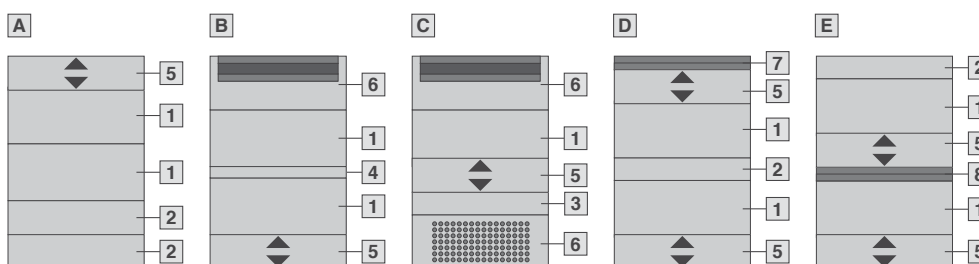

- 1 Gland plate, depth 250 mm
- 2 Gland plate, depth 150 mm
- 3 Gland plate, depth 100 mm
- 4 Gland plate, depth 50 mm
- 5 Sliding panel, depth 150 mm
- 6 Module plate, depth 237.5 mm
- 7 Self-adhesive foam cable clamp strip
- 8 Section for cable entry, centre

#### ! Also required:

Base mount, see page 22.

#### Note:

Total installation depth 912 mm

# System Accessories

## Base



### For enclosure depth 1200 mm

A Gland plate set	Packs of	Required packs of	For enclosure width mm	
			600	800
			Model No. DK	
Gland plate, solid, with sliding panel, multi-piece	1 set	1	5502.560	5502.570

Gland plate modules	Packs of	Required packs of	For enclosure width mm	
			600	800

B 1 module plate as selected			Model No. DK		
Gland plate, depth 250 mm	1	3	5001.222	5001.223	
Sliding panel, depth 150 mm	1	1	5001.239	5001.240	
Module plate, depth 237.5 mm	1	1	Vented with airflow regulator	7825.366	7825.386
			Cable entry with brush strip	7825.361	7825.381
			Vented	7825.360	7825.380
			Cable entry with brush strip, super-airtight	7825.367	7825.387
Cable entry, side			-	7825.388	

C 2 module plates as selected			Model No. DK		
Gland plate, depth 250 mm	1	2	5001.222	5001.223	
Gland plate, depth 50 mm	1	1	5001.218	5001.219	
Sliding panel, depth 150 mm	1	1	5001.239	5001.240	
Module plate, depth 237.5 mm	1	2	Vented with airflow regulator	7825.366	7825.386
			Cable entry with brush strip	7825.361	7825.381
			Vented	7825.360	7825.380
			Cable entry with brush strip, super-airtight	7825.367	7825.387
			Cable entry, side	-	7825.388

D Cable entry, rear or front			Model No. DK	
Gland plate, depth 250 mm	1	2	5001.222	5001.223
Gland plate, depth 150 mm	1	3	5001.218	5001.219
Sliding panel, depth 150 mm	1	1	5001.239	5001.240
Self-adhesive foam cable clamp strip	3 m	1	2573.000	2573.000

E Cable entry, centre			Model No. DK	
Gland plate, depth 250 mm	1	2	5001.222	5001.223
Gland plate, depth 150 mm	1	3	5001.218	5001.219
Sliding panel, depth 150 mm	1	1	5001.239	5001.240
Section for cable entry, centre	1 set	1	2573.000	2573.000

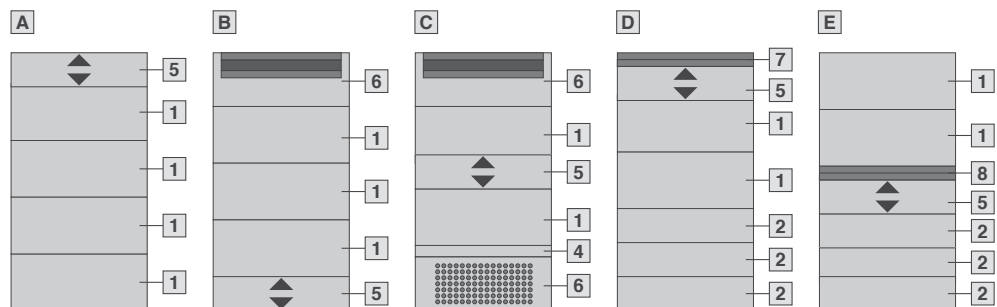

- 1 Gland plate, depth 250 mm
- 2 Gland plate, depth 150 mm
- 3 Gland plate, depth 100 mm
- 4 Gland plate, depth 50 mm
- 5 Sliding panel, depth 150 mm
- 6 Module plate, depth 237.5 mm
- 7 Self-adhesive foam cable clamp strip
- 8 Section for cable entry, centre

**!** Also required:

Base mount, see page 22.

**Note:**

Total installation depth 1112 mm

# System Accessories

## System lights

### Compact light

#### Slimmer – Faster – Brighter

- Slimmer: Around 50% less height and depth and also around 75% less volume than conventional lights.
- Faster: Universal fast attachment via clips, screws, or powerful magnets (optional). Simply slide in at the side or rear, fit the light, and it's done!
- Brighter: Up to 75% greater luminous efficiency from the lamp with the same power helps to cut electricity costs.
- Door-operated switch can also be connected via a 2-pole connection.

**Material:**  
Sheet steel

**Surface finish:**  
Zinc-plated

**Supply includes:**  
Assembly parts.



#### Accessories:

- Mounting kit, magnet, see page 27.
- Door-operated switch with connection cable, SZ 4315.720.

**Note:**  
Other lights, see Catalogue 33, from page 491.

Model No. SZ	ENEC 24	4140.010	-	4140.02	-	4140.110	4140.120
	cURus	-	4140.210 <sup>1)</sup>	-	4140.220 <sup>1)</sup>	-	-
Rated voltage	100 - 240 V AC ±10% at 50 - 60 Hz				24 V DC ±10%		
Wattage	8		14		8		14
Protection category	II (all-insulated)						
Width (B1) mm	455		705		455		705
Mounting distance (B2) mm clip/magnet	400		650		400		650
Mounting distance (B3) mm	475		725		475		725
Connection cable	3 m (open end)						
Cover colour	Yellow	Grey	Yellow	Grey	Yellow	Yellow	
Rated current (A)							
- at 230 V AC	0.045 - 0.088		0.073 - 0.127		-		-
- at 110 V AC	0.083 - 0.149		0.149 - 0.216		-		-
- at 24 V DC	-		-		0.35		0.57
Light	Fluorescent lamp T5						
Operating unit	Wide-range electronic ballast				Electronic ballast		
Circuit breakers	Integral, on/off/door-operated switch mode						
Light cover	Transparent, grooved on the inside						
Cable deflector	-	-	-	-	-	-	-

<sup>1)</sup> Only for the Northern American market

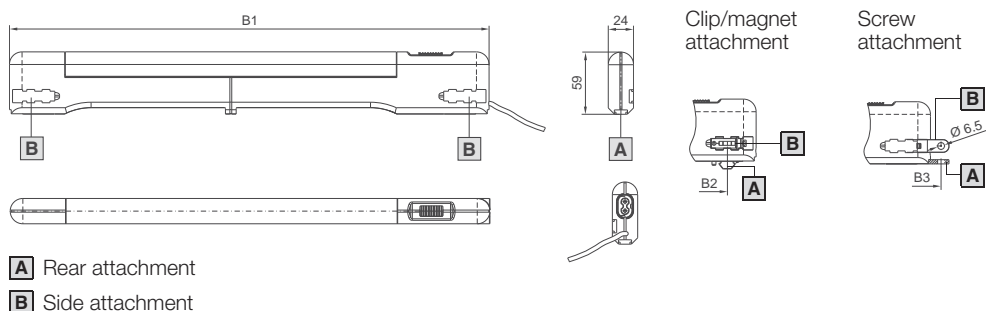

### Mounting kit, magnet

For reliable adhesion on all sheet steel surfaces.

Packs of	Model No. SZ
2	4140.000



# Power Module Concept



## PMC 12

- A compact single-phase UPS with scalable autonomy up to 55 minutes at 100% load produces a broad application spectrum
- Modules with 1/2/3/6 and 10 kVA, single-phase
- Redundancy n+1
- Installation in 482.6 mm (19"), 2 U or floor-standing enclosure
- Batteries "hot-swap" compatible, may be exchanged from the front
- Scalable to 30kVA

## PMC 40

- Installation in racks with two 482.6 mm (19") levels from a depth of 800 mm.
- Modules with 10 and 20 kW, 3-phase
- Redundancy n+1
- "Safe swap" capability with redundancy: Safe module exchange with the system operational, no need to switch to bypass mode

## PMC 40 (Type 5)

- TS 8 rack with max. 3 UPS modules and battery pack
- Compact size, only 800 mm enclosure depth
- 10/20 kW UPS output modules (3-phase)
- Up to 40 kW n+1 redundant (max. 60 kW)
- High operating ratio of 95%, even in part-load operation
- Expansion/maintenance/module exchange while operational ("safe swap")
- Additional battery rack possible to increase autonomy

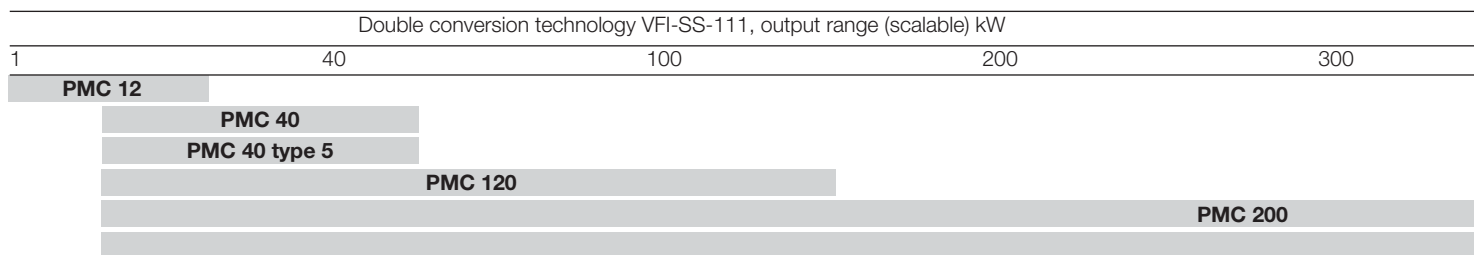



## PMC 120

- TS 8 rack with max. 6 UPS modules in one compact enclosure
- Compact size, only 800 mm enclosure depth
- 10/20 kW UPS output modules (3-phase)
- Up to 100 kW n+1 redundant UPS output (max. 120 kW)
- High operating ratio of 95%, even in part-load operation
- Expansion/maintenance/module exchange while operational ("safe swap")
- Batteries in external battery racks support long autonomies

## PMC 200

- Maximum availability, modularity and compact design ensure flexible, almost unlimited scalability and redundancy
- The benefits to you: Less capital tie-up, inexpensive expansion, and minimal space requirements
- Modules with 8/12/16/20/24/32/40 kW, 3-phase
- Redundancy n+1
- Installation: Intergrated into the rack
- Scalability up to 20 modules. This facilitates a maximum output of up to 800 kW or 760 kW n+1
- Modular expansion of output and autonomy with the system operational

## PMC 800

- Maximum availability and performance in a modular design
- The separation of the modules into one power module and one control module is exemplary for this output class. This ensures a high level of service-friendliness and allows precise planning of maintenance work
- Modules with 64 and 80 kW, 3-phase
- Redundancy n+1
- Installation: Intergrated into the rack
- Scalability up to 12 modules. This facilitates a maximum output of up to 960 kW or 880 kW n+1
- The "safe swap" technology allows UPS modules (in inverter mode) to be replaced or the UPS extended with the system operational

Double conversion technology VFI-SS-111, output range (scalable) kW

PMC 800

# UPS - Power Module Concept

## Uninterruptible power supply

1000 / 2000 / 3000 / 6000 / 10000 VA Rack / Tower

### True Online Double Conversion

- True 240V Sine Wave Output
- Wide input voltage window
- Lighting & surge protection

### Tower or Rack Mountable (same unit)

- Easy to install

### 1kVA up to 30kVA

- Scalable from a small 1kVA UPS to 30 kVA UPS just by adding modules

### Units can be Paralleled

- For redundancy 1N (N+1 Configuration)



Model No. DK	XAU7857.430A	XAU7857.431A	XAU7857.432A	XAU7857.433A	XAU7857.434A
--------------	--------------	--------------	--------------	--------------	--------------

Performance					
kVA	1kVA	2kVA	3kVA	6kVA	10kVA
Power Rating (W)	800	1600	2400	5400	9000
Internal Batteries	Yes	Yes	Yes	No	No
Max External Battery Pack	2	2	2	3	3
Technology	On-line double conversion with static bypass				
Input Voltage (AC)	120~290		176~280		
Input Frequency	50Hz ± 5%				
Input Power Factor	0.99				
Output voltage	240 Vac ± 3%				
Output power factor (Pf)	0.8		0.9		
Output frequency	50Hz ± 0.5Hz				
Efficiency	> 88%		> 90%		

Battery					
Model No. DK	XAU7857.435A	XAU7857.436A	XAU7857.437A	XAU7857.442A	XAU7857.443A
Backup time at full load	5 min (Internal)		4 min (Internal)	5 min (battery pack)	2 min (Battery Pack)
Backup time at ½ load	14 min (internal)		12 min (internal)	12 min (battery pack)	10 min (battery pack)
Battery test	Programmable automatic test (via free software supplied)				
Battery notes	1, 2 & 3kVA supplier standard with internal batteries. 6 & 10kVA supplied with no internal batteries. Backup times shown above for 6 & 10kVA = 1 x UPS module + 1 external battery pack.				

Input / Output connection					
Input	IEC 320 C14 (10 A)		IEC 320 C20 (15 A)		Terminal strip
Output (tower)	IEC 320 C13 (10 A)				Terminal strip

Power management	
Standard port	Standard RS232 & USB interfaces
Intellislots	1 slot for optional SNMP / web card (7857420A) or relay card (7857410A)
Remote power off	Yes with OS shutdown software (standard)

Dimensions					
W x H x D mm	440 x 88 (2U) x 405	440 x 88 (2U) x 650		440 x 88 (2U) x 680	440 x 132 (3U) x 680

Environmental	
Operating temperature	0°C ~+ 40°C, recommended +20°C ~+ 25°C
Humidity	0% - 90%
Storage temperature	0°C - 40°C
Altitude	0---2000m (nominal), 2000---3000m (de-rating)
Acoustic noise (1 m from front panel)	≤45dB

Conformance	
Approval	CE, UL, C-Tick
Safety	EN62040-1, IEC62040-1, UL1778
EMC	EN50091-2 Class B, IEC/EN62040-2 Class A, FCC Class A

\*Specifications subject to change without prior notice.



# UPS - Power Module Concept

## Battery packs

### for PMC 12

To operate or increase the power of PMC 12 UPS systems. With overload protection. Vertical siting is also possible. Battery packs are "hot plug"- compatible (replacement of batteries while operational). Batteries can be exchanged from the front, without removing the battery pack from the 482.6 mm (19") level. Depending on the UPS version, 2 – 3 battery packs may be connected together to increase the autonomy. Cooling of the UPS and the battery packs is absolutely essential.

### Material:

Maintenance-free lead gel accumulators, service life 5 years (to EUROBAT)

### Supply includes:

- Fully preassembled and populated with batteries
- 0.5 m connection cable with connector
- Feet.

### Note:

For mounting in the 482.6 mm (19") rack, a slide rail DK 5501.480 is required.



UPS PMC 12 model	Standard version					XL version	
	XAU7857.430A	XAU7857.431A	XAU7857.432A	XAU7857.433A	XAU7857.434A	7857.48	7857.48
<b>Battery pack model number to suit</b>	<b>XAU7857.435A</b>	<b>XAU7857.436A</b>	<b>XAU7857.437A</b>	<b>XAU7857.442A</b>	<b>XAU7857.443A</b>	<b>7857.49</b>	<b>7857.49</b>
Width (mm)	465	465	465	465	465	465	465
Height (mm) (RU)	89 (2U)	89 (2U)	89 (2 U)	133.5 (3U)	133.5 (3U)	178 (4U)	178 (4U)
Depth (mm)	650	650	650	650	650	420	420
Weight (kg)	35	35	35	55	70	35	35
Number of batteries per battery pack	12 (7Ah)	12 (7Ah)	6 (9Ah)	20 (7Ah)	20 (9Ah)	12 (7Ah)	12 (7Ah)

## PMC 12 - Additional Accessories

### UPS monitoring card (SNMP card)

Design	Model No.
SNMP Card	XAU7857.420A

### Relay Card

Design	Model No.
Relay Card	XAU7857.410A

Note: Cannot be used together with the SNMP Card

### Mechanical Maintenance Bypass Switch

Design	Model No.
1 - 3 kVA (include UPS fuse 16A)	7857.440
6 kVA (include UPS fuse 32A)	7857.441

### Slide rails, depth-variable, 1 RU

482.6 mm (19") distance between levels (mm)	Load Capacity (kg)	Packs of	Model No.
400 - 600	80	2	5501.460
600 - 900	150	2	5501.480

### Parallel hot swap chassis for 6 kVA and 10 kVA only

Design	Model No.
Parraellel Cable Kit	XAU7857.421A
For 2 UPS Systems	7857.443
For 3 UPS Systems	7857.444



# UPS Accessories



## Sub-distribution

### 482.6 mm (19") sub-distribution for PMC 12

Outlets 4 x C19 and 2 x 32 A CEE-conforming Single-phase, individually fused. Allows the direct connection of up to 6 pieces of equipment. A qualified electrician must carry out the installation.

Pack	Model No. DK
1	7857.445



## PMC 12 Plug & Play

### Sub-distribution for PMC 12 6 kVA

This sub-distribution facilitates simple installation and commissioning of the PMC 12 UPS and 6 kVA. All that is needed is a single-phase 32 A connection to DIN/EN 60 309.

Pack	Model No. DK
1	7857.448



## Sub-distribution

### Sub-distribution for PMC 40

Allows the direct, fused connection of single- and 3-phase equipment. In this way, up to 4 PSM busbars may be connected directly to the PMC 40 UPS via the relevant connection cables.

Pack	Model No. DK
1	7857.500

# UPS PMC 40

## Cable routing/cable clamping

### UPS PMC 40

**3-phase, output range scalable 10-40 kW**  
 PMC 40 - compact, rack-independent UPS system (up to 40 kW, 3-phase)

This uses “double conversion” UPS technology according to the highest classification VFI-SS-111, which provides a constant output irrespective of the incoming voltage, coupled with a high overall operating ratio and minimal space requirements.

The PMC 40 may be configured as a redundant system. As a general principle, it is important to ensure adequate climate control of the rack where the PMC 40 is installed. For installation purposes, the rack must have two 482.6 mm (19”) mounting levels and a minimum depth of 800 mm. Depending on the configuration, mixed population (e.g. with servers) in the same rack is also supported.

The PMC 40 (redundant design) has “safe swap” capabilities. This allows easy, safe module exchange while the system is operational, without having to switch the UPS to bypass mode.

**Supply includes:**

A PMC 40 UPS system is comprised of a basic unit for 482.6 mm (19”) installation. 1 – 2 UPS modules and, depending on the version, a maximum of two battery packs per UPS module may be integrated into this basic module. The configured complete system comes with basic unit and UPS module(s). Battery packs are supplied separately.

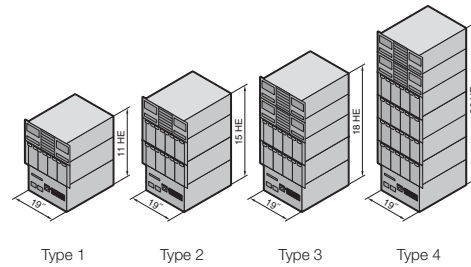

		Type 1	Type 2	Type 3	Type 4
Number of UPS modules		1	1	2	2
Number of battery packs		1	2	2	4
Maximum UPS output (with 10 kW/20 kW module)	kW	10	10/20	20	20/40
UPS output with 1+1 redundancy (with 10 kW/20 kW module)	kW	-	-	10	10/20
Approx. autonomies at 100% load (with 10 kW/20 kW modules)	min.	6/-	15/5	6/-	16/5
Approx. autonomies at 50% load (with 10 kW/20 kW modules)	min.	12/-	30/10	12/-	32/10
RS232 (D-Sub 9) and USB interface (configuration and shutdown)	Qty.	1/1	1/1	1/1	1/1
Fault signal contacts (floating)	Qty.	5	5	5	5
Clamping strip input (3L+N+PE) max. conductor cross-section	mm <sup>2</sup>	10/16	10/16	10/16	10/16
Clamping strip output (3L+N+PE) max. conductor cross-section	mm <sup>2</sup>	10/16	10/16	10/16	10/16
Dimensions	Width (B)	mm 485 (19")	485 (19")	485 (19")	485 (19")
	Height (H)	U 11	15	18	26
	Depth (T)	mm 735	735	735	735
Required distance between 482.6 mm (19”) levels (min./max.)	mm	690-800	690-800	690-800	690-800
Weight (approx. incl. batteries and UPS modules)	kg	162	278	310	537
<b>Model No. DK basic unit</b>		<b>7040.010</b>	<b>7040.020</b>	<b>7040.030</b>	<b>7040.040</b>
<b>Model No. DK PMC 40 10 kW module (order quantity. acc. to type)</b>		1x <b>7040.110</b>	1x <b>7040.110</b>	2x <b>7040.110</b>	2x <b>7040.110</b>
<b>Model No. DK PMC 40 20 kW module (order quantity. acc. to type)</b>		-	1x <b>7040.120</b>	-	2x <b>7040.120</b>
<b>Model No. DK PMC 40 battery pack per n x 4 x 10 batteries (12 V/7 Ah) prewired (service life 5 acc. to EUROBAT) n = 1, 2, 4</b>		<b>7040.211</b>	<b>7040.212</b>	<b>7040.212</b>	<b>7040.214</b>
<b>Model No. DK PMC 40 battery preparation (for export or air freight) Drawers and battery cabling (excluding battery, quantity depending on type)</b>		<b>7040.201</b>	<b>7040.202</b>	<b>7040.203</b>	<b>7040.204</b>

**Accessories**

SNMP monitoring card (budget)	<b>7857.420</b>
RCCMD licence, bundle with 5 licences for selective shutdown of 5 computers (only available in conjunction with UPS hardware)	<b>7857.423</b>
RCCMD licence, bundle with 25 licences for selective shutdown of 25 computers (only available in conjunction with UPS hardware)	<b>7857.424</b>

**Note:** Only UPS modules with an identical output may be combined.

# UPS Power Module Concept



## UPS Rack With Integral Power Modules And Batteries

- Thanks to the double conversion technology (VFI-SS-111) the output voltage is independent from the input voltage and frequency
- Efficient IGBT power transistor technology achieves a high operating ratio of 95% even in part-load operation
- "Safe swap" compatibility with a redundant design, i.e. the module may be exchanged while operational
- Every UPS module includes power electronics as well as the control unit including display
- Installation, commissioning and servicing to be carried out by authorised experts only

### Supply includes:

- UPS system in the TS 8 rack
- Vented front and rear door
- Fitted with UPS power modules (depending on configuration) and batteries
- The batteries must only be installed at the point of assembly and are delivered separately

### Note:

Only UPS modules with an identical output may be combined. Technical information/ battery configurations: Available on the Internet.

## PMC 40 (type 5), 3-phase, output range scalable 10-40 kW, redundant

Dimensions (UPS rack, without base/plinth) width x height x depth mm	Packs of	600 x 2000 x 800	600 x 2000 x 1000
<b>Model No. UPS basic rack</b>		<b>7040.065</b>	<b>7040.060</b>
Maximum no. of UPS modules			3
Maximum no. of battery packs			4
Maximum UPS output (with 10 kW/20 kW modules)			30/60 kW
UPS output with n+1 redundancy (with 10 kW/20 kW modules)			20/40 kW
RS232 (D-Sub 9) and USB interface (configuration and shutdown)			1/1
Fault signal contacts (floating)			5
Clamping strip input/output (3L+N+PE) max. conductor cross-section			35/50 mm <sup>2</sup>
Weight (approximate, incl. batteries and 3 UPS modules)			740 kg
Protection category of UPS system			IP 20
Operating temperature range (UPS with batteries, recommended)			20 - 25°C
Accessibility only required to front (for servicing, maintenance)			900 mm
Distance from wall to rear (due to fan cooling)			200 mm
<b>Model No. PMC 40 10 kW module (order quantity acc. to output)</b>	1		<b>7040.110</b>
<b>Model No. PMC 40 20 kW module (order quantity acc. to output)</b>	1		<b>7040.120</b>
<b>Model No. PMC 40 battery pack 1 x 4 x 10 batteries, when using 10 kW modules (12 V/7 Ah) prewired (service life 5 years under EUROBAT) Order volume n = 2.3 x</b>	40		<b>7040.311</b>
<b>Model No. PMC 40 battery pack 1 x 5 x 10 batteries, when using 20 kW modules (12 V/7 Ah) prewired (service life 5 years under EUROBAT) Order volume n = 3.4 x</b>	50		<b>7040.315</b>
<b>Model No. PMC battery preparation n x 4 x 10 (for export of airfreight)</b> Drawers and battery cabling (n = 3.4 without batteries), cable set of 40	1 set		<b>7040.301</b>
<b>Model No. PMC battery preparation n x 5 x 10 (for export of airfreight)</b> Drawers and battery cabling (n = 3.4 without batteries), cable set of 50	1 set		<b>7040.305</b>
<b>Accessories</b>			
UPS monitoring/SNMP monitoring card	1		7040.420
Base/plinth components, front and rear, RAL 7035, 100 mm high	1 set		8601.605
Base/plinth components, sides, RAL 7035, 800 mm deep/100 mm high	1 set		8601.085
Base/plinth components, sides, RAL 7035, 1000 mm deep/100 mm high	1 set		8601.015

# UPS Power Module Concept



## Modular UPS System (up to 120 kW)

- UPS power modules operate according to the double conversion principle (classification to VFI-SS-111) and have a transformerless design thanks to the high intermediate circuit voltage
- Efficient IGBT power transistor technology achieves a high operating ratio of 95% even in part-load operation
- “Safe swap” compatibility with a redundant design, i.e. the module may be exchanged while operational
- Every UPS module includes power electronics as well as the control unit including display
- Installation, commissioning and servicing to be carried out by authorised experts only

### Supply includes:

- UPS system in the TS 8 rack
- Vented front and rear door
- Fitted with UPS power modules (depending on configuration) and batteries

### Note:

Only UPS modules with an identical output may be combined.  
Battery configurations:  
Available on the Internet.

## PMC 120, 3-phase, output range scalable 10-120 kW

Dimensions (UPS rack, without base/plinth) width x height x depth mm	Packs of	600 x 2000 x 800	600 x 2000 x 1000
<b>Model No. UPS basic rack</b>		<b>7040.075</b>	<b>7040.070</b>
Maximum no. of UPS modules		6	
Maximum UPS output (with 10 kW/20 kW modules)		60/120 kW	
UPS output with n+1 redundancy (with 10 kW/20 kW modules)		50/100 kW	
No. of batteries (12 V/28 Ah) per module/battery bank (per 10 kW/20 kW)		40/50	
No. of battery banks per battery rack <sup>1)</sup> , max.		3	
No. of batteries (12 V/28 Ah) per battery rack <sup>1)</sup> , max.		150	
Operating ratio (from 50% load)		95%	
Operating ratio in eco-mode (100% load)		98%	
RS232 (D-Sub 9) and USB interface (configuration and shutdown)		1/1	
Fault signal contacts (floating)		5	
Input (3L+N+PE) conductor cross-section		70/95 mm <sup>2</sup>	
Output (3L+N+PE) conductor cross-section		70/95 mm <sup>2</sup>	
Battery connection (2 x M10, joint batteries) conductor cross-section		150 mm <sup>2</sup>	
Weight (approx., UPS rack with 6 UPS modules)		285kg	
Protection category of UPS system		IP 20	
Operating temperature range (UPS with batteries, recommended)		20 - 25°C	
Accessibility only required to front (for servicing, maintenance)		900 mm	
Distance from wall at rear (due to fan cooling)		200 mm	
<b>Model No. PMC 40 10 kW module (order quantity acc. to output)</b>	1	<b>7040.110</b>	
<b>Model No. PMC 40 20 kW module (order quantity acc. to output)</b>	1	<b>7040.120</b>	
<b>Also required</b>			
<b>Battery rack, width 800 mm (max. 150 batteries)</b>	1	<b>7040.361<sup>1)</sup></b>	<b>7857.364<sup>1)</sup></b>
<b>Accessories</b>			
Base/plinth components, front and rear, RAL 7035, 100 mm high	1 set	8601.605	
Base/plinth components, sides, RAL 7035, 800 mm deep/100 mm high	1 set	8601.085	
Base/plinth components, sides, RAL 7035, 1000 mm deep/100 mm high	1 set	8601.015	

<sup>1)</sup> Batteries not included with the supply of the battery rack

# UPS PMC 200



## UPS PMC 200

Rittal PMC 200 ensures optimum availability for critical applications by combining modularity (flexible, unlimited scalability and redundancy, whereby up to 20 modules may be switched in parallel) with decentralised parallel architecture or DPA (redundant protection without a "single point of failure"). The UPS modules are transformerless, genuine online, double-conversion UPSs with static bypass and classification code VFI-SS-111.

This modular concept keeps the purchasing and operating costs of redundant solutions exceptionally low. As your performance requirements grow, the UPS grows with you, thanks to its flexible scalability – even in the most confined spaces, and with the system operational.

### The benefits to you:

- Pay as you grow approach, minimising CAPEX whilst retaining flexibility for the future
- Highest levels of availability thanks to short MTTR and long MTBF
- Rightsizing of UPS provides better efficiencies for redundancy
- Safe swap technology enables modules to be removed or added without any downtime
- High efficiency even at low loads
- No single point of failure in overall architecture
- No de-rating of UPS with leading power factors up to 0.9

Module range (per rack)		Up to 100 kW				Up to 200 kW		
Module power	kW	8	12	16	20	24	32	40
<b>1. Rectifier data</b>								
Nominal input voltage	V	3 x 380/220 V+N, 3 x 400/230 V+N, 3 x 415/240 V+N						
Input voltage tolerance	V	3 x 306/177 V to 3 x 464/264 V for < 100% load 3 x 280/161 V to 3 x 464/264 V for < 80% load 3 x 160/138 V to 3 x 464/264 V for < 60% load						
Input frequency	Hz	35 - 70						
Power factor input		PF = 0.99 @ 100% load						
Distortion factor, THDI		Sine-wave THDI = < 3% @ 100% load						
<b>2. Battery specifications (maintenance-free lead and NiCd)</b>								
No. of 12 V batteries		30 - 50	40 - 50	40 - 50	30 - 50	40 - 50	30 - 50	40 - 50
Battery changing curve		Ripple free: IU (DIN 41 773)						
<b>3. Output data</b>								
Power output per module	kVA	10	15	20	25	30	40	45
Output power per module at cos phi 0.8 ind. to cos phi 0.9 cap	kW	8	12	16	20	24	32	40
Output voltage	V	3 x 380/220 V or 3 x 400/230 V or 3 x 415/240 V						
Operating ratio AC - AC at 100%/75%/50%/25% load (cos phi 1.0)	%	95/95/95/95						
Eco-mode operating ratio at 100% load	%	98						
<b>4. General technical specifications</b>								
Safety		En 62 040-1-1: 2003, EN 60 950-1: 2006						
EMC		2006, EN 61 000-3-2: 2000, EN 61 000-3-3: 2006, EN 61 000-6-2: 2006, EN 61 000-6-4: 2002						
Classification code VFI-SS-111		EN 62 040-3: 2002						
Product conformity		CE						
Protection category		IP 20						
Noise level at 100%/50% load	dB (A)	55/49	57/49	57/49	55/49	59/51	63/53	63/53
Parallel configuration		Up to 20 modules						

## 3-phase, output range scalable 8-800kW

**A Safe Investment – Almost Unlimited**

### Scalability

Up to 20 PMC modules may be gradually switched in parallel e.g. in order to supply 800 kW without redundancy or 760 kW n+1 (with 40 kW modules) uninterrupted. May be upgraded with the system operational; no need to switch over to an unprotected network.

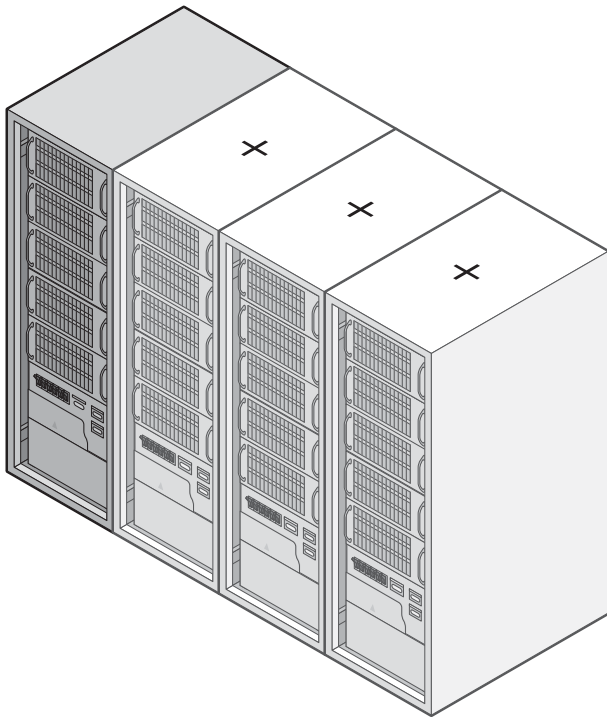

PMC 200 3-Ph UPS	Model No. DK
PMC 200	7857.580
PMC 200 module 10kVA / 8kW	7857.210
PMC 200 module 15kVA / 12kW	7857.215
PMC 200 module 20kVA / 16kW	7857.220
PMC 200 module 25kVA / 20kW	7857.225
PMC 200 module 30kVA / 24kW	7857.230
PMC 200 module 40kVA / 32kW	7857.235
PMC 200 module 45kVA / 40kW	7857.240
Trays and links for PMC 60	7960.020
Trays and links for PMC 120	7960.030
Battery rack (800 x 2000 x 1000) max. 150 batt. - common	7857.364
Battery rack (600 x 2000 x 1000) max. 120 batt. - common	7857.590
Battery rack (600 x 2000 x 1000) max. 120 batt. - separate	7857.396
Battery rack (600 x 2000 x 1000) max. 150 batt. - separate	7857.398
Trays for battery rack 120 - 7857.590 / 7857.396	7857.386
Links (cables) for battery rack 120 - 7857.590 / 7857.396	7857.387
Trays for battery rack 150 - 7857.364 / 7857.398	7857.388
Links (cables) for battery rack 150 - 7857.364 / 7857.398	7857.389
Battery string 7Ah (10 batteries)	7857.373
Battery string 28Ah (10 batteries)	7857.374
Parallel cable kit for linking 2 PMC 200 racks	7960.030
Sub-distributor with 12 3-ph outlets - 16 A	7857.309
SNMP card	7857.366
RCCMD license (Win-NT, UNIX, Novell) - 25 users	7857.424

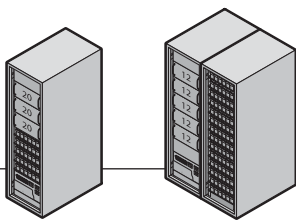

UPS racks: W 600 x H 2000 x D 1000 mm  
Battery racks: W 600 x H 2000 x D 1000 mm

Redundancy	without	with	without	with	without	with	without	with	without	with
UPS rack/battery rack	1/-	-	1/-	1/-	1/-	1/-	1/1	1/1	1/1	1/1
Number of UPS modules	1	-	2	2	3	3	4	4	5	5
<b>PMC 12 module type, power in kW</b>	<b>12</b>	-	<b>25</b>	<b>12</b>	<b>36</b>	<b>24</b>	<b>48</b>	<b>36</b>	<b>60</b>	<b>48</b>
Battery autonomy	60	-	14	14	14	14	24	24	24	24
<b>PMC 20 module type, power in kW</b>	<b>20</b>	-	<b>40</b>	<b>20</b>	<b>60</b>	<b>40</b>	<b>80</b>	<b>60</b>	<b>100</b>	<b>80</b>
Battery autonomy	33	-	7	7	7	7	12	12	12	12

### Note:

This table contains only sample configurations.  
We would be pleased to configure your individual solution with you.

# GPO Power Rail



## Horizontal & vertical power rails

- 10 Amp / 15 Amp
- All fixing hardware included
- Includes 3m lead with captive plug
- 20 Amp versions available on request
- IEC plugs also available on request

### Colour:

RAL 9005 Black

### Horizontal Features:

Mounts to 19" mounting Rails

### Vertical Features:

Mounts to all frame elements

Part No.	Outlets Type 1	Orientation	Dimensions L x RU x D	Plug Type	Special Notes	Mounting
XAUPQ06AEEBK	6 x 10 Amp GPO	Horizontal	420 x 44.45 x 44.5	10 Amp GPO captive	10 Amp thermal overload	19"
XAUPQ12AEEBK	12 x 10 Amp GPO	Horizontal	420 x 88.9 x 44.5	10 Amp GPO captive	10 Amp thermal overload	19"
XAUPQ12AEEBKV	12 x 10 Amp GPO	Vertical	756 x 44.45 x 44.5	10 Amp GPO captive	10 Amp thermal overload	Sliding bracket system
XAUPQ21AEEBK	21 x 10 Amp GPO	Vertical	1260 x 44.45 x 44.5	10 Amp GPO captive	10 Amp thermal overload	Sliding bracket system
XAUPQ06EFEBK	6 x 15 Amp GPO	Horizontal	420 x 44.45 x 44.5	15 Amp GPO captive	15 Amp thermal overload	19"
XAUPQ12EFEBK	12 x 15 Amp GPO	Horizontal	420 x 44.45 x 44.5	15 Amp GPO captive	15 Amp thermal overload	19"
XAUPQ12EFEBKV	12 x 15 Amp GPO	Vertical	756 x 44.45 x 44.5	15 Amp GPO captive	15 Amp thermal overload	Sliding bracket system
XAUPQ21EFEBK	12 x 15 Amp GPO	Vertical	1260 x 44.45 x 44.5	15 Amp GPO captive	15 Amp thermal overload	Sliding bracket system



# PDUi - Power Distribution Unit



## Benefits:

- With the compact PDU, any IT rack may be easily equipped with a professional power distribution system. With the TS IT rack, assembly is even tool-free
- Compact design
- Easy to assemble
- Power-saving design, minimal consumption by the PDU itself, thanks to the use of bistable relays and OLED display with power-saving function
- Integral Web server for direct network connection with extensive user administration (not PDU basic/slave PDU)
- Redundant power supply from all 3 phases and additionally via an existing PoE (Power over Ethernet) network
- Extensive range of management and monitoring functions
- High-MTBF and measurement accuracy of 1%
- CAN bus for connecting slave PDUs (not PDU basic)
- Ambient monitoring with up to 4 CMC III sensors (temperature, humidity, access, vandalism)

## PDU design variants:

### PDU basic

Robust, compact basic power distributor for the IT environment

### PDU metered

Energy measurement per phase, i.e. output requirement of an entire IT rack

### PDU switched

Measurement function per phase and individually switchable output slots

### PDU managed

High-end IT rack, power distribution with energy measurement and monitoring functions for each individual output slot

## Material:

Extruded aluminium section, anodised

## Protection category:

IP 20 to EN 60 529

## Supply includes:

Assembly parts for tool-free mounting or screw-fastening.

## Standards:

- EN 60 950
- EN 61 000-4
- EN 61 000-6
- EN 55 022

## Low Voltage Directive:

2006/95/EC

## EMC Directive:

2004/108/EC

Photo shows a configuration example with equipment not included in the scope of supply.

# PDUi - Power Distribution Unit

## Configuration examples

PDU Version1)	managed/ managed slave <sup>2)</sup>	switched	metered	basic
<b>Mechanical</b>				
<b>May be fitted in the Zero-U space in the 600 mm wide Rittal IT rack, tool-free</b>	-	-	-	-
Colour coding of phases and fuse circuits (depending on PDU version)	-	-	-	-
Connection cable, static, 3 m, with CEE connector (IEC 60 309) or C20	-	-	-	-
<b>Connector lock for C13 and C19 pin patterns (optional)</b>	-	-	-	-
<b>Lockable cover for unneeded slots (for C13/C19)</b>	-	-	-	-
PDU slave version without display and Ethernet connection for use with PDU master and CMC III	-	-	-	-
<b>Electrical</b>				
Power supply 110 V - 230 V/400 V, inherent consumption approx. 15 W	-	-	-	-
Rated current 16 A/32 A, single-phase/3-phase	-	-	-	-
Version additionally 63 A/3-phase (blade PDU, no Zero-U)	-	-	-	-
Electromagnetic safety switch, 16 A, type C (only with 32 A/63 A PDU versions)	-	-	-	-
PDU self-supplied, no external power supply required	-	-	-	-
PDU power supply redundant across all phases (with 3-phase PDUs)	-	-	-	-
Emergency power supply to PDU web server via PoE (Power over Ethernet), remains accessible even in the event of a mains failure	-	-	-	-
Switching function per output slot	-	-	-	-
Sequential activation of the outputs once the power is resumed (avoids overload peaks)	-	-	-	-
Switching states are saved even in the event of a power failure	-	-	-	-
<b>Bistable relays/minimal power consumption</b>	-	-	-	-
Grouping (joint switching of several outputs)	-	-	-	-
<b>Measurement functions</b>				
Voltage (V), current (A), frequency (Hz)	-	-	-	-
Active power (kW), active energy (kWh), apparent power (VA), apparent energy (kVA)	-	-	-	-
<b>Power factor (cos phi)</b>	-	-	-	-
<b>Zero conductor measurement/load imbalance detection</b>	-	-	-	-
Fuse monitoring (with 32 A/63 A versions)	-	-	-	-
Measurement per phase or infeed	-	-	-	-
Measurement per output slot	-	-	-	-
Measurement accuracy 1% (kWh) to IEC 50 430-1	-	-	-	-
<b>Connectivity/management functions</b>				
Powerful 500 MHz CPU and Linux operating system (not with slave versions)	-	-	-	-
Graphic OLED display 128 x 128 pixels (RGB) with back-lighting and energy-saving mode (display of output data and basic IP configuration)	-	-	-	-
Position sensor for display rotation (and correct visualisation in the DCIM software RiZone)	-	-	-	-
Multi-colour LEDs (green/amber/red) to indicate switching states and limits per phase or infeed	-	-	-	-
Multi-colour LEDs (green/amber/red) to indicate switching states and limits per individual output slot	-	-	-	-
Settable limits (warning/alarm)	-	-	-	-
Operating hours meter, total and cyclical (resettable)	-	-	-	-
Ethernet connection (RJ45)	-	-	-	-
USB A-port for firmware update and datalogging functions	-	-	-	-
CAN bus interface (RJ45)	-	-	-	-
Web server (HTTP, HTTPS, SSL, SSH) NTP, Telnet	-	-	-	-
TCP/IP v4 and v6, DHCP	-	-	-	-
SNMP v1, v2c and v3	-	-	-	-
FTP/SFTP (update/file transfer)	-	-	-	-
E-mail forwarding in case of alarm (SMTP)	-	-	-	-
<b>User administration including rights management</b>	-	-	-	-
<b>LDAP(S)/Radius/Active Directory connection</b>	-	-	-	-
Syslog server connection (max. 4 servers)	-	-	-	-
Plug & play drivers in the Rittal RiZone DCIM software	-	-	-	-
MIB for linking into 3rd party software	-	-	-	-
Suitable for connection to Rittal CMC III system	-	-	-	-
<b>CMC III CAN bus sensors may be connected for ambient monitoring (max. 4 sensors)</b>	-	-	-	-
CMC III sensors that may be used: Temperature sensor, temperature/humidity sensor, infrared access sensor, vandalism sensor	-	-	-	-
<b>Ambient conditions</b>				
Operating temperature	0 to 50°C	0 to 50°C	0 to 50°C	0 to 50°C
Storage temperature	-25 to +70°C	-25 to +70°C	-25 to +70°C	-25 to +70°C
Ambient humidity (non-condensing)	10 - 95%	10 - 95%	10 - 95%	10 - 95%
Protection category to IEC 60 529	IP 20	IP 20	IP 20	IP 20

1) Special versions with UL approval or alternative slot configurations available on request.

2) Managed slave without display/network.

# PDUi - Power Distribution Unit

## PDU international, basic version

Power		Pin patterns			Dimensions		Model No. DK
No. of phases	Phase current	Input	Outputs C 13	Outputs C 19	PDU length mm	Minimum enclosure height mm	
1	16 A	CEE	24	4	970	1200	7955.110
1	32 A	CEE	24	4	1110	1400	7955.111
3	16 A	CEE	18	3	845	1000	7955.131
3	16 A	CEE	24	6	1140	1400	7955.132
3	32 A	CEE	24	6	1360	1600	7955.133
3	32 A	CEE	36	6	1700	2000	7955.134
3	16 A	CEE	42	None	1400	1600	7955.135

## PDU international, metered version

Power		Pin patterns			Dimensions		Model No. DK
No. of phases	Phase current	Input	Outputs C 13	Outputs C 19	PDU length mm	Minimum enclosure height mm	
1	16 A	C20	12	None	580	800	7955.201
1	16 A	CEE	24	4	1220	1400	7955.210
1	32 A	CEE	24	4	1360	1600	7955.211
3	16 A	CEE	18	3	1095	1200	7955.231
3	16 A	CEE	24	6	1390	1600	7955.232
3	32 A	CEE	24	6	1610	1800	7955.233
3	32 A	CEE	36	6	1950	2200	7955.234
3	16 A	CEE	42	None	1650	2000	7955.235
3	32 A	CEE	48	None	1830	2200	7955.236
3	63 A	CEE	12	12	-	1200	7955.238

## PDU international, switched version

Power		Pin patterns			Dimensions		Model No. DK
No. of phases	Phase current	Input	Outputs C 13	Outputs C 19	PDU length mm	Minimum enclosure height mm	
1	16 A	C20	12	None	580	800	7955.301
1	16 A	CEE	24	4	1220	1400	7955.310
1	32 A	CEE	24	4	1360	1600	7955.311
3	16 A	CEE	18	3	1095	1200	7955.331
3	16 A	CEE	24	6	1390	1600	7955.332
3	32 A	CEE	24	6	1610	1800	7955.333
3	32 A	CEE	36	6	1950	2200	7955.334
3	16 A	CEE	42	None	1750	2000	7955.335
3	32 A	CEE	48	None	1830	2200	7955.336

## PDU international, managed version

Power		Pin patterns			Dimensions		Model No. DK
No. of phases	Phase current	Input	Outputs C 13	Outputs C 19	PDU length mm	Minimum enclosure height mm	
1	16 A	C20	12	None	580	800	7955.401
1	16 A	CEE	24	4	1220	1400	7955.410
1	32 A	CEE	24	4	1360	1600	7955.411
3	16 A	CEE	18	3	1095	1200	7955.431
3	16 A	CEE	24	6	1390	1600	7955.432
3	32 A	CEE	24	6	1610	1800	7955.433
3	32 A	CEE	36	6	1950	2200	7955.434
3	16 A	CEE	42	None	1750	2000	7955.435
3	32 A	CEE	48	None	1830	2200	7955.436

# PSM - Power System Module



## Power distribution directly in the IT rack

Modern, powerful servers such as blade server systems have an increasingly high energy power demand. This necessitates corresponding power distribution components directly in the IT rack. To this end, Rittal has developed the intelligent Power System Module (PSM) which intelligently meets current demands for power management and performance data logging at server level. Requirements such as operational reliability, redundancy and extendibility with the system operational have been consistently implemented.

As a bar system for IT racks, our PSM has complete contact hazard protection. The outputs are designed as plug-in modules available for the various pin patterns and application scenarios. The bar system with three-phase circuits has a redundant design.

This means that outputs of up to 22 kW (2 x 3 x 16 A) can be distributed across up to seven module slots via the PSM bar. There are also variants with 3 x 32 A or 1 x 32 A infeed. Special versions (PSM+) have four three-phase infeeds which doubles the output. Upon request, several PSM bars may be integrated into one IT rack, facilitating the physical separation of A and B supplies in the rack.

Other application options include – the deactivation of individual racks or components in the event of alarm messages – this may be utilised via the active Rittal PSMs with switching function and current measurement at server level.

### The benefits to you:

- A wide range of PSM bars with complete contact hazard protection in a compact, patented design
- Flexibly extendible with the system operational
- MID-conforming for consumption calculations, and with a VDE-tested design
- Repurchase guarantee for standard systems
- Also with switching function for the outputs, current and output measurement or optical load display

# PSM - Power System Module

## Busbars

### PSM busbars + PSM socket modules

#### PSM busbars

The modular system facilitates basic configuration of the racks, thanks to a vertical support rail with single-/3-phase infeed. The various socket modules to supply the active components may be snap-fitted into the support rail. This can even be done whilst the system is operational, because the support section is shock-hazard protected.

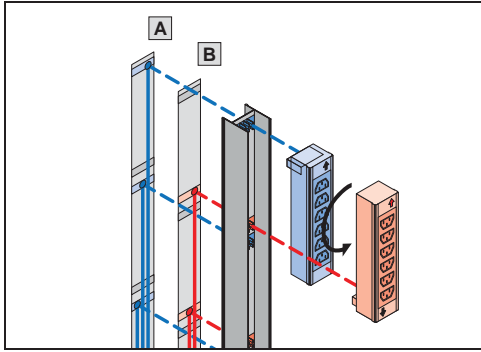

#### PSM socket modules

The various modules, earthing pins, IEC320 etc. may be inserted into the support rail in any combination. This is easily achieved, even by non-electricians, thanks to the shock hazard protected plug & play system.

#### Approvals:

Available on the Internet.

#### Technical specifications/benefits:

- Each plug-in module picks off a phase on the support rail, either from infeed A or from the redundant infeed B, depending on the direction of connection.
- Single-/3-phase construction with a maximum current of 2 x (3 x 16 A). 3-phase redundant infeed supported.
- The redundant circuit is completely separate from the 3 phases of the support rail.
- Modules may be retrofitted whilst operational.
- Modules may be equipped with integral overcurrent protection, so that only the affected module is deactivated in the event of an excessively high current. The other modules remain operational.
- Overvoltage protection may be integrated into the supply line.
- Various modules also available with current measurement and switchable outputs.

### PSM busbars

For enclosure height mm	Phases per infeed	No. of infeeds	Input current (A)	Maximum no. of module slots	Connection, connector type	Circuit-breaker 16 A	Earth-leakage circuit-breaker	Packs of	Model No. DK
<b>1 With measurement of voltage, current and power (consumption), via CMC-TC, remote controllable</b>									
2000	3	2	16	6	Jack	-	-	1	7859.050
2000	1	1	32	6	CEE	2	-	1	7859.053
<b>2 With 2 infeeds (jack), 3-phase redundancy</b>									
1200	3	2	16	4	Jack	-	-	1	7856.010
2000	3	2	16	7	Jack	-	-	1	7856.020
2200	3	2	16	8	Jack	-	-	1	7856.008
<b>3 With 3 m connection cable (wire and ferrules)</b>									
2000	3	1	16	7	Wire and ferrules	-	-	1	7856.005
2000	3	2	16	7	Wire and ferrules	-	-	1	7856.006
<b>4 With 3 m connection cable (connector type CEE/EN 60 309)</b>									
2000	1	1	32	6	CEE	2	-	1	7856.321
2000	3	1	32	6	CEE	6	-	1	7856.323
2000	1	1	32	6	CEE	2	-	1	7856.043

#### ! Also required:

PSM socket modules, see page 44.

#### + Accessories:

- Mounting kit for PSM busbars, see page 45.
- Connection cables, see page 45.
- Cable lock, see page 45.
- Overvoltage protection, see page 45.



# PSM - Power System Module

## Socket modules



### PSM socket modules

Module slots required in PSM busbar	Connector pattern	Slots	Thermal overcurrent protection	Packs of	Model No.
<b>1 Standard socket modules/non-switches</b>					
1	C13	6	-	1	7856.080
1	C13	6	-	1	7856.070
1	C13	4	-/per output	1	7856.220
1	C19	4	-	1	7856.230
1	C13 red	6	-	1	7856.082
2	C13	8	RCD	1	7856.095
<b>3 Socket modules with LED display/current measurement per module</b>					
1	C13	6	-	1	7859.120
1	C19	4	-	1	7859.204
<b>4 Socket modules with switchable slot/aggregate current measurement per module</b>					
2	C13	8	-	1	7856.201
2	C19/C13	4/2	-	1	7856.204
<b>5 Socket modules with switchable slot/individual current measurement per slot</b>					
2	C13	8	-	1	7859.222
2	C19/C13	4/2	-	1	7859.232

**Approvals:**  
Available on the Internet.

# PSM - Power System Module

## Socket modules

### PSM mounting kit

#### for TS IT

- For tool-free mounting of the PSM busbar on the horizontal TS 8 frame
- Fast assembly
- Orientation of the PSM busbar either to the enclosure centre or to the rear
- Without cable routing

#### Material:

Sheet steel, zinc-plated

#### Supply includes:

Assembly parts.

Packs of	Model No. DK
1 set	7856.029



### Connection cable

#### for PSM-busbar

#### Connection cable, 3-phase

	Length	Packs of	Model No. DK
CEE-conforming 5-pole/16 A	3 m	1	7856.025

#### Connection cable, single-phase

CEE-conforming 3-pole/16 A	3 m	1	7856.026
----------------------------	-----	---	----------

#### Connection cable, single-phase

C14/X-Com 10 A	3 m	1	7856.027
----------------	-----	---	----------

C20/X-Com 16 A	3 m	1	7856.030
----------------	-----	---	----------

#### Connection cable, single-phase

16 A	2 m	1	7200.217
------	-----	---	----------

#### Connection cable, single-phase

16 A	0.5 m	2	7856.014
------	-------	---	----------



### Cable lock PSM

#### for all modules with EN 60 320 C13 connector configurations

All terminal connection cables are therefore protected against unintentional disconnection of the power supply. Two bars are needed for two cables.

Design	Packs of	Model No. DK
Bar	20	7856.029



### Overvoltage protection PSM

Is connected upstream of the busbar.

- Fine fuse
- Connection:
  - Socket Wago X-Com
  - Connector Wago X-Com

Overvoltage protection	Packs of	Model No. DK
With adapter connector	1	7856.170

#### Note:

One adaptor is required for each feed.



# Climate Control

## High-end solutions for the lowest energy costs

On average, 37% of the energy costs in data centres are attributable to the cooling infrastructure. For this reason, Rittal focuses particular attention on energy-efficient cooling components and cross-system control concepts.

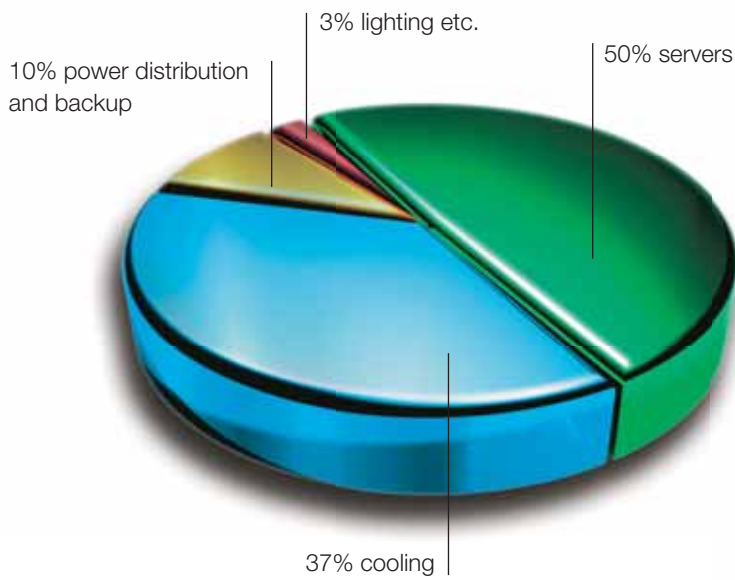

- 1 Rittal aisle containment
- 2 CRAC systems
- 3 LCP Plus/Smart
- 4 IT chillers
- 5 Free cooling
- 6 Pipework
- 7 Raised floor for cold air supply

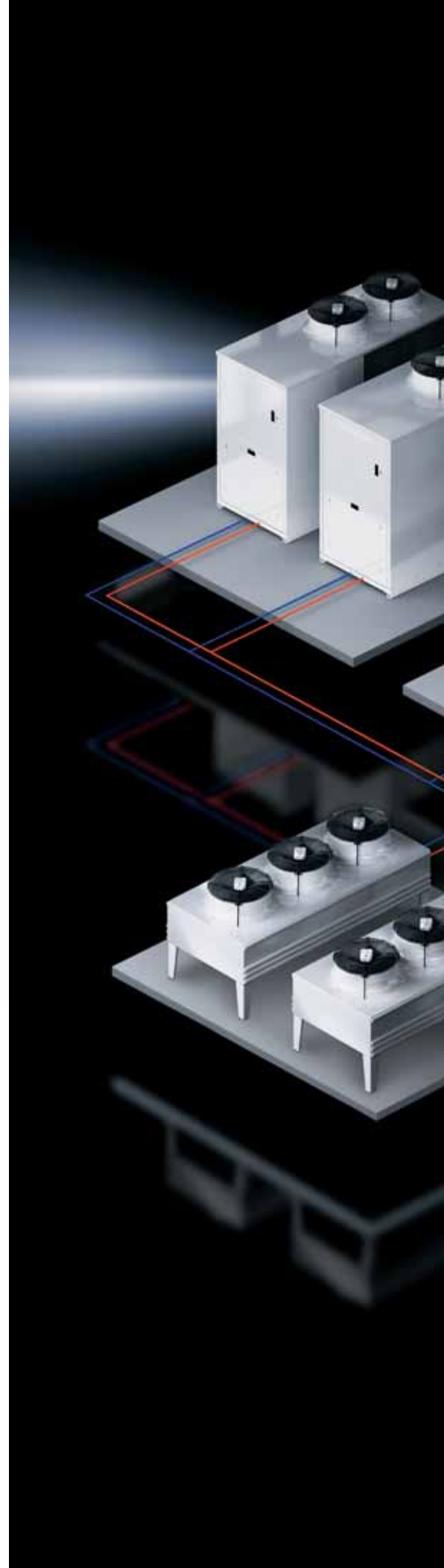



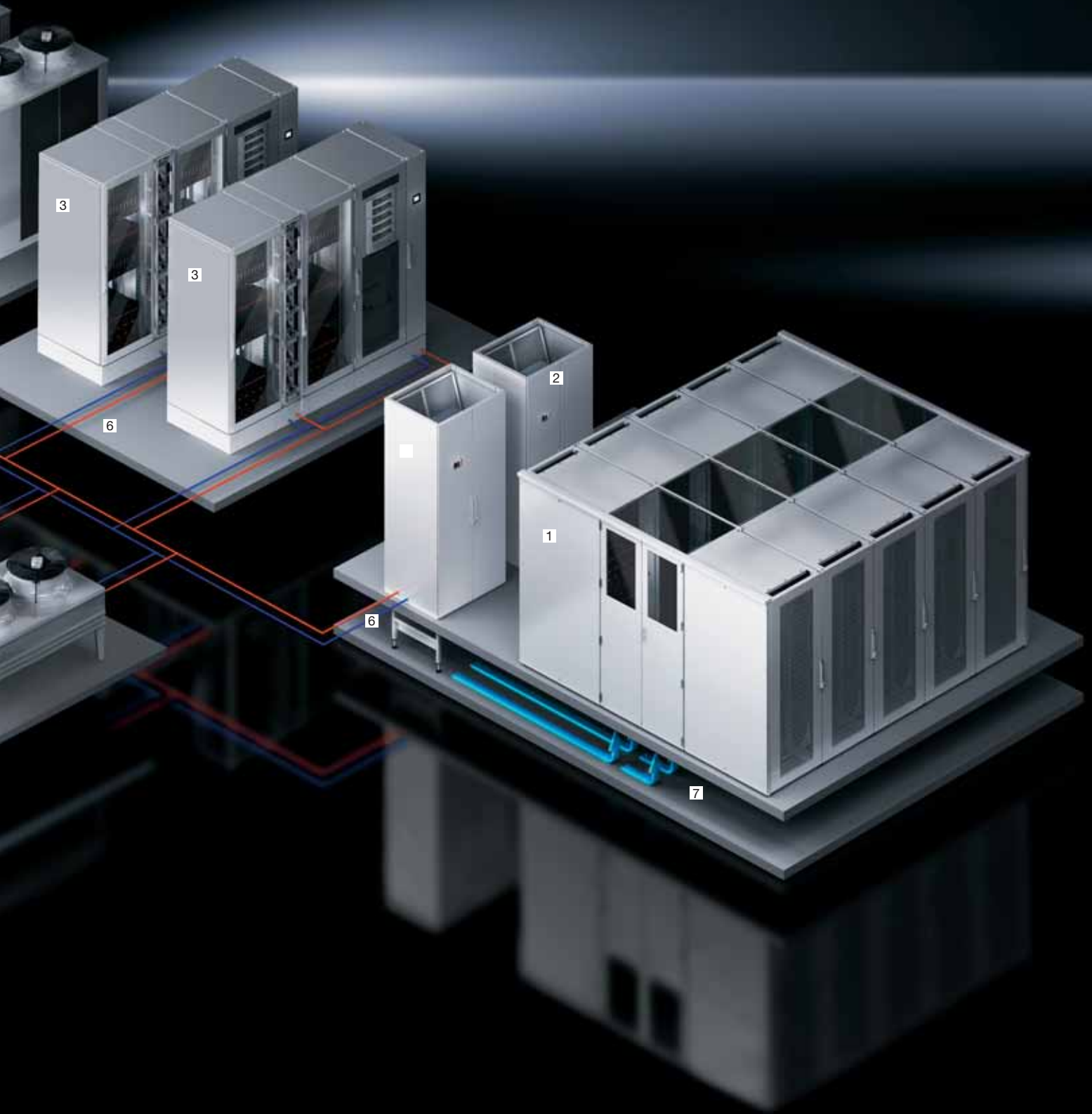

# Climate Control

## Rittal liquid cooling package LCP

Climate control of your data centre is becoming ever more important in terms of availability and energy costs. The Rittal Liquid Cooling concepts ensure precise, problem free heat loss dissipation of up to 60 kW per rack.

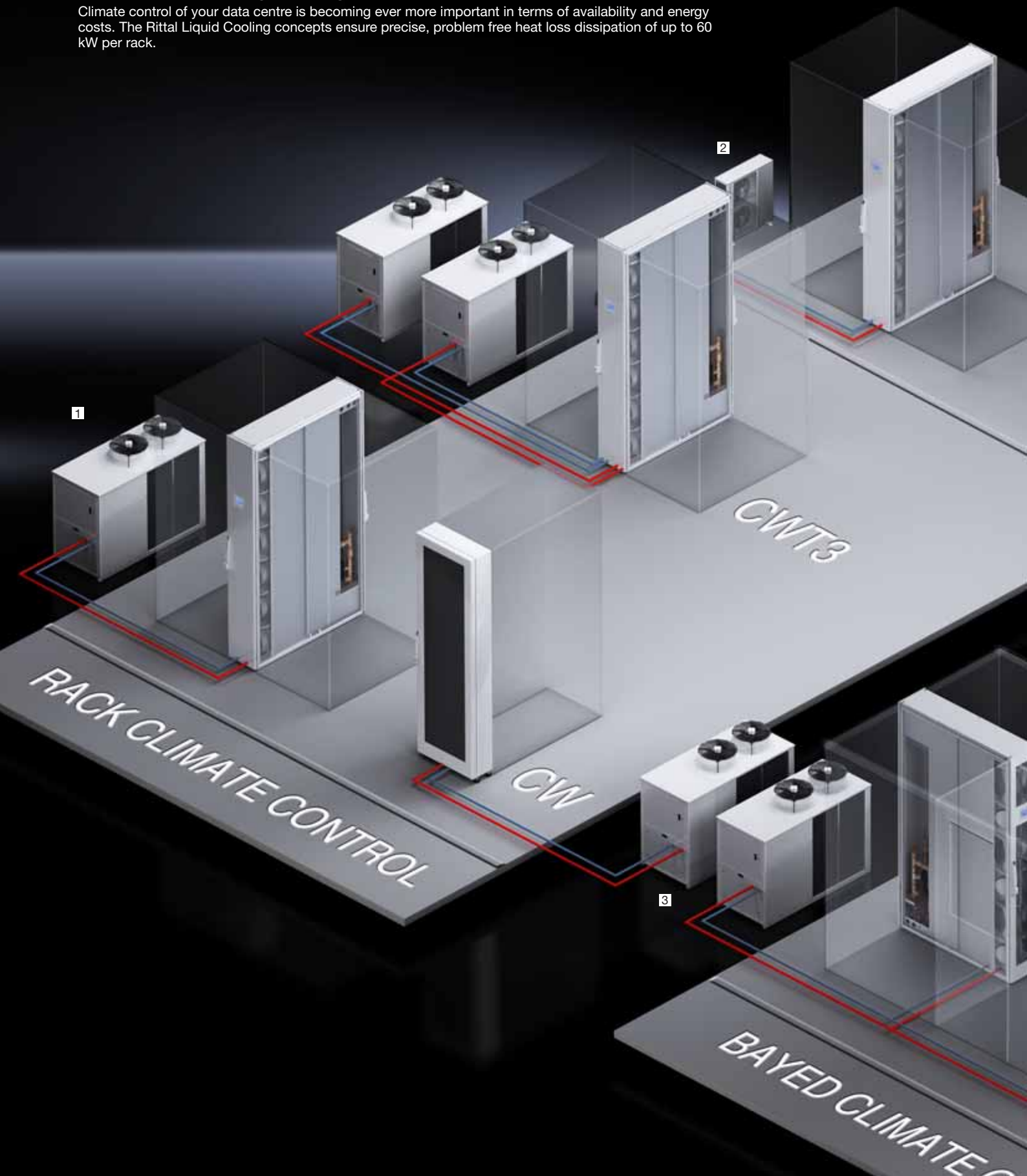

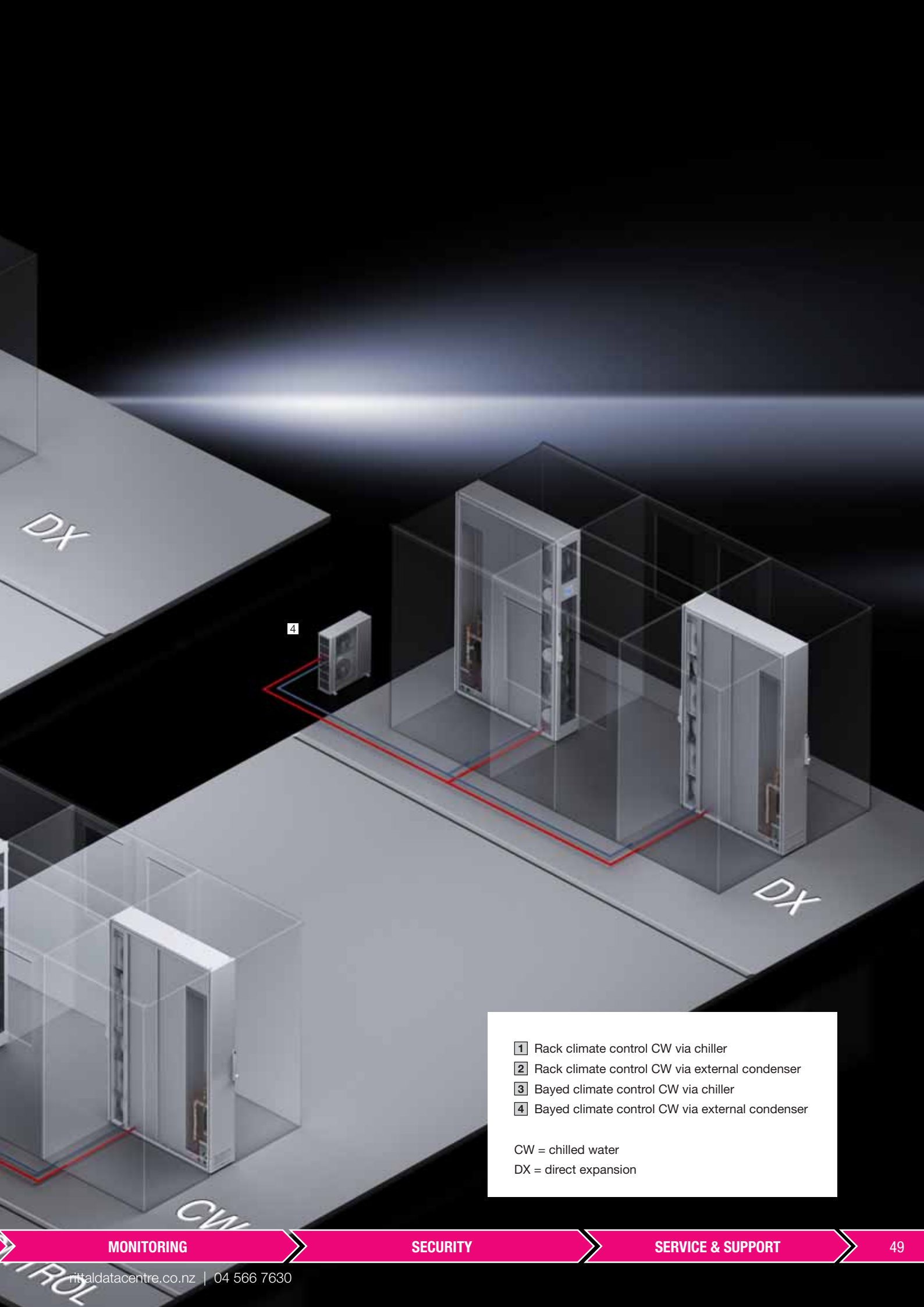

4

- 1 Rack climate control CW via chiller
- 2 Rack climate control CW via external condenser
- 3 Bayed climate control CW via chiller
- 4 Bayed climate control CW via external condenser

CW = chilled water  
DX = direct expansion

# IT Roof-Mounted Cooling Units



The IT roof-mounted cooling unit, with its regulated air intake and front-to-back air routing, is specifically designed for the energy efficient climate control of IT racks.

#### Technical specifications:

- Duty cycle: 100 %
- Type of connection: Plug-in terminal strip

#### Protection category:

- External circuit IP 34 to IEC 60 529
- Internal circuit IP 54 to IEC 60 529

#### Supply includes:

- Nano-coated condenser
- Integral electric condensate evaporation
- Fully wired ready for connection
- Drilling template
- Assembly parts

#### Approvals:

Available on the Internet.

#### Detailed drawings:

Available on the Internet.

#### Performance diagrams:

Available on the Internet.

## TopTherm, useful cooling output 3000 W

Model No. SK	3301.800		Cat. 33, page	
Material	Sheet steel			
Colour	RAL 7035			
Rated operating voltage V, Hz	230, 1~, 50			
Dimensions mm	W x H x D	597 x 417 x 895		
Useful cooling output $Q_k$ to DIN 3168	L 35 L 35	3000 W		
	L 35 L 50	3200 W		
Rated current max.	9.2 A			
Start-up current	36.0 A			
Pre-fuse T	Circuit-breaker 16.0 A			
Power consumption $P_{el}$ to DIN 3168	L 35 L 35	1820 W		
	L 35 L 50	2325 W		
Refrigeration factor $\epsilon = Q_k/P_{el}$	L 35 L 35	1.6		
Refrigerant	R134a, 700 g			
Operating temperature and setting range	+20°C to +50°C			
Weight	72 kg			
Air throughput of fans	External circuit	1850 m <sup>3</sup> /h		
	Internal circuit	1450 m <sup>3</sup> /h		
Temperature control	e-Comfort controller (regulation of air intake temperature)			
<b>Accessories</b>	Packs of			
Air baffle plate, roof	1	Available on request		
Air baffle plate for side containment	600 mm wide	1	7151.206	565
	800 mm wide	1	7151.208	565
Quick-change frame	1	3286.900	297	
Cage nuts	50	2094.400	568	
SK BUS system	1	3124.100	295	
Blanking panel	1	7151.110	571	
Condensate hose	1	3301.612	303	

Special voltages available on request. We reserve the right to make technical modifications. Unassigned U must be sealed with blanking panels in order to utilise the front-to-back air routing.

# Water-Based Cooling Solution

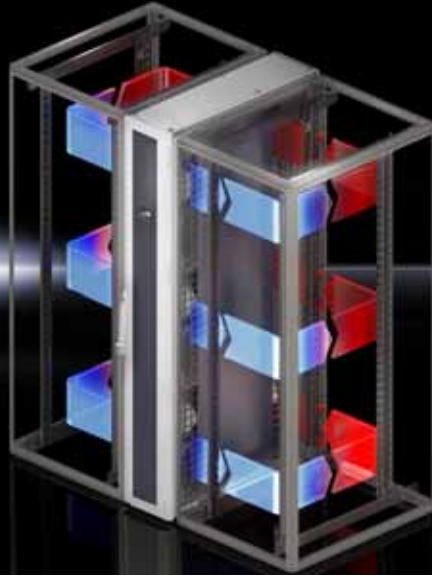

## Rack cooling

Data centres support corporate processes at ever-higher outputs. The packing density in computer systems is increasing, and processor capacity is growing. This leads to a continuous rise in heat development.

Keep temperatures at a constant level with the highly efficient Rittal Liquid Cooling Packages (LCP). With optimised operating costs, our LCPs precisely and effortlessly dissipate heat losses of up to 24 kW per enclosure.

### LCP Rack T3+, CW

- Redundant heat exchanger unit with two active water circuits (A/B medium supply)
- Redundant power infeed (A/B power supply) with automatic changeover in case of an emergency
- Fully redundant cooling output of 24 kW
- Redundant fan design
- Integrated controller with its own web server for network and BMS interfaces
- Auto-load balancing function
- Auto-recovery function
- Energy saving with high water inlet temperatures (more free cooling)
- Minimised operating costs with efficient EC fan technology
- Integration into RiZone (data centre management software)

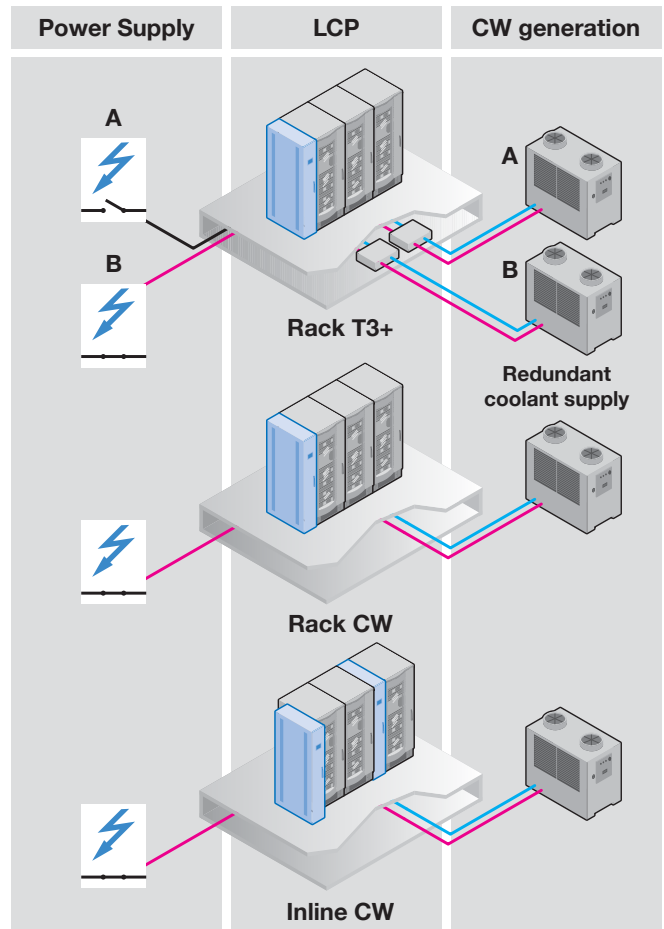

# Water-Based Cooling Solution

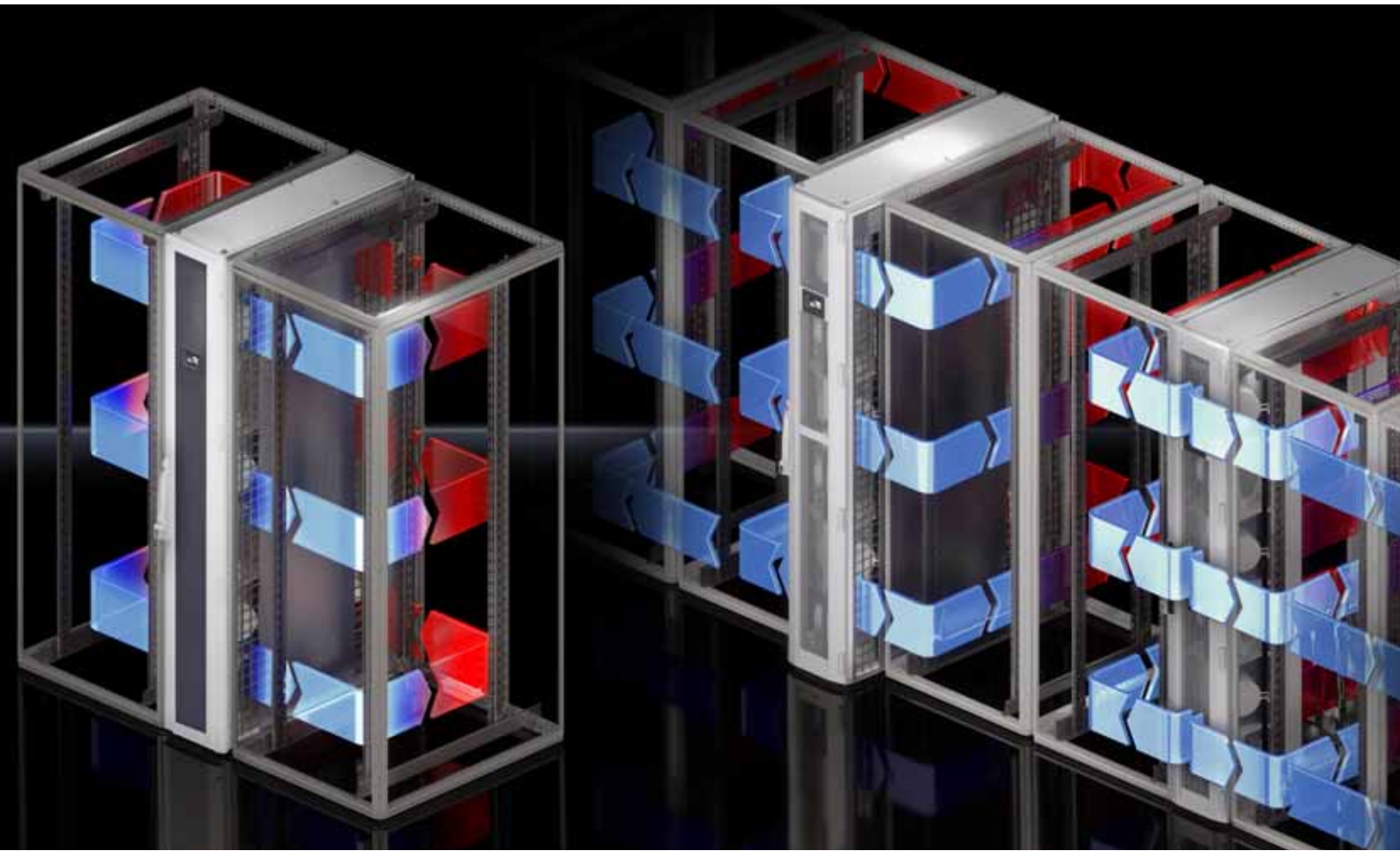

## Rack cooling

Data centres support corporate processes at ever-higher outputs. The packing density in computer systems is increasing, and processor capacity is growing. This leads to a continuous rise in heat development.

Keep temperatures at a constant level with the highly efficient Rittal Liquid Cooling Packages (LCP). With optimised operating costs, our LCPs precisely and effortlessly dissipate heat losses of up to 55 kW per enclosure.

### LCP Rack CW

- Cooling output from 10 kW to 55 kW
- Energy saving with high water inlet temperatures (more free cooling)
- Minimised operating costs with efficient EC fan technology
- Spatial separation of cooling and server rack
- Integral condensate and leakage management
- Sophisticated control concept including online connection
- Optional cooling of one or two server racks
- Simple representation of redundancies
- Assembly- and service-friendly
- Integration into RiZone (data centre management software)

## Suite cooling

Bayed suite cooling with the Rittal LCP Inline is extremely powerful, and the ideal climate control solution for exceptionally high cooling demands, particularly when the cooling of server racks cannot be achieved via the room climate control.

Alternatively, bayed suite cooling can be used to support the existing climate control system in the room or for transforming existing structures into server rooms. A raised floor is not necessary for the operation of suite cooling.

### LCP Inline CW

- Cooling output from 10 kW to 55 kW
- Cooling of several server racks
- Energy saving with high water inlet temperatures (more free cooling)
- Minimised operating costs with efficient EC fan technology
- Spatial separation of cooling and server rack
- Integral condensate and leakage management
- Sophisticated control concept including online connection
- Assembly- and service-friendly
- Optional front cover to reduce the air outlet speed and for superior air distribution
- Increased performance and efficiency in conjunction with Rittal aisle containment
- Integration into RiZone (data centre management software)
- Variant set forward for ideal air distribution (cold air curtain)
- Flush variant for confined spaces (narrow cold aisle)

# Refrigerant-Based Cooling Solution

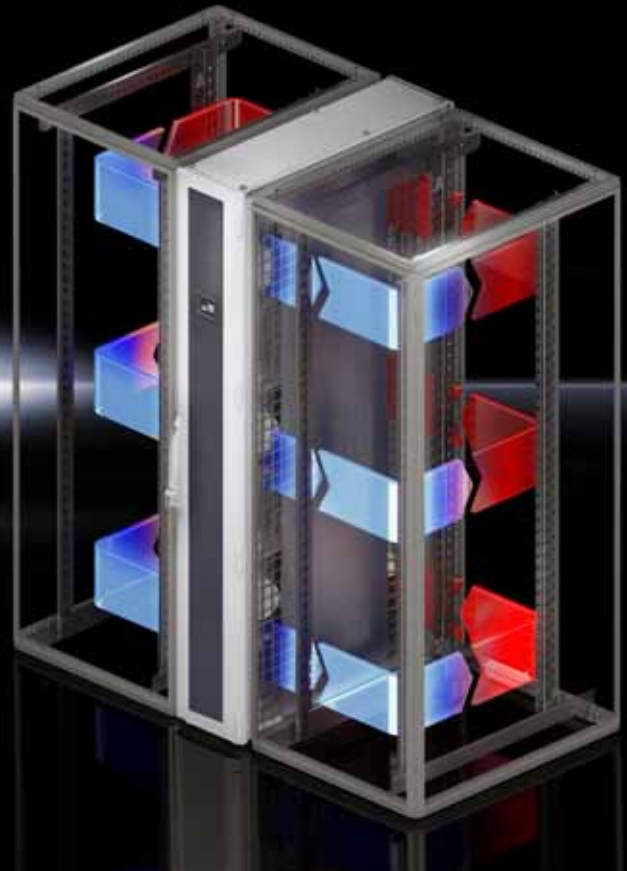

## Rack cooling

Whether rack-based cooling of one or two server racks, or suite cooling with aisle containment. LCP Rack DX or LCP Inline DX are the ideal cooling solution for small to medium-sized IT installations. In particular, the stand-alone IT application is easily cooled with these devices.

Whereas in the past, cooling of stand-alone IT applications led to difficulties with conventional ceilings or air-conditioning units, the LCP DX devices support IT-compatible cooling. For retrofitting or exchanges, the existing coolant pipework can often be reused.

### LCP Rack DX

- Cooling output 12 kW
- Refrigerant R410a
- Minimised operating costs with efficient EC fan technology
- Spatial separation of cooling and server rack
- Integral condensate and leakage management
- Sophisticated control concept including online connection
- Optional cooling of one or two server racks
- Simple representation of redundancies
- Assembly- and service-friendly
- Integration into RiZone (data centre management software)
- Cost-effective installation by laying small-diameter coolant lines

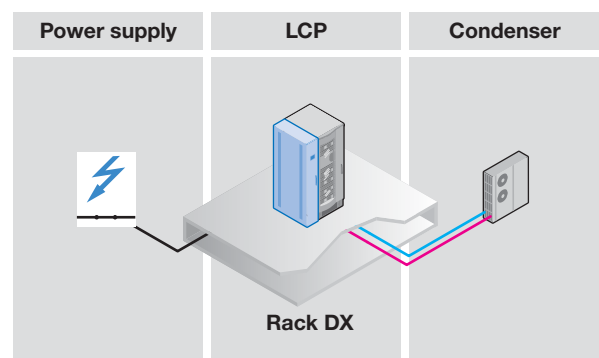

# Refrigerant-Based Cooling Solution

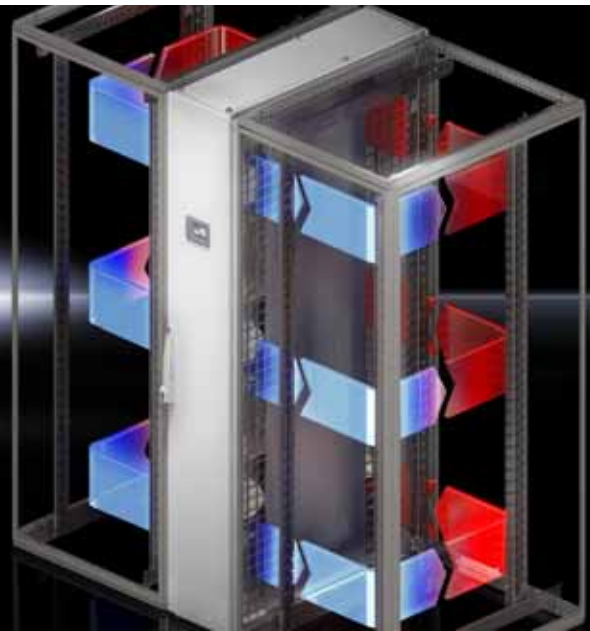

## Suite cooling

Whether rack-based cooling of one or two server racks, or suite cooling with aisle containment, LCP Rack DX and LCP Inline DX are the ideal cooling solution for small to medium-sized IT installations. In particular, the stand-alone IT application is easily cooled with these devices.

Whereas in the past, cooling of stand-alone IT applications led to difficulties with conventional ceilings or air-conditioning units, the LCP DX devices allow IT-compatible cooling. For retrofitting or exchanges, the existing coolant pipework can often be reused.

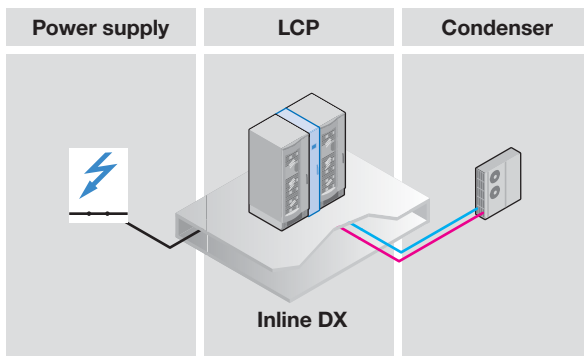

### LCP Inline DX

- Cooling output 12 kW
- Cooling of several server racks
- Refrigerant R410a
- Minimised operating costs with efficient EC fan technology
- Spatial separation of cooling and server rack
- Integral condensate and leakage management
- Sophisticated control concept including online connection
- Assembly- and service-friendly
- Optional front cover to reduce the air outlet speed and for superior air distribution
- Increased performance and efficiency in conjunction with Rittal aisle containment
- Integration into RiZone (data centre management software)



# LCP – Liquid Cooling Package CW



## Benefits:

- Maximum energy efficiency thanks to EC fan technology and IT-based control
- Minimal pressure loss at the air end, which in turn minimises the power consumption of the fans
- Optimum adaptability thanks to dynamic, continuous control of the cold water volume flow
- Using high water inlet temperatures increases the proportion of indirect free cooling, which in turn reduces operating costs
- Targeted cooling output thanks to modular box-type plug-in fan units

- Box-type plug-in fan units configurable as n+1 redundancy
- Standard 3-phase connection for electrical redundancy
- With redundant temperature sensor integrated at the air end as standard
- The separation of cooling and rack prevents the ingress of water into the server enclosure
- Up to 55 kW cooling output on a footprint of just 0.36 m<sup>2</sup>
- Minimal area load thanks to low weight
- Touchscreen display may be retrofitted

## Monitoring:

- Monitoring of all system-relevant parameters such as:
- Server air intake temperature
  - Server waste air temperature
  - Water inlet/return temperature
  - Water flow
  - Cooling output
  - Fan speed
  - Leakage
  - Optional sensors
  - Direct connection of the unit via SNMP over Ethernet
  - Integration into RiZone (data centre management software)

## Application and mode of operation:

The LCP draws in the air at the sides at the rear of the server

enclosures, cools it using high-performance compact impellers, and blows the cooled air back into the front part of the server enclosure at the sides.

## Colour:

- RAL 7035
- Special colours available on request

## Protection category:

- IP 40 to IEC 60 529

## Technical information:

Available on the Internet. Photo shows a configuration example with equipment not included in the scope of supply

## LCP Rack CW

Cooling medium	Water (see Internet for specifications)											
<b>Model No.</b>	<b>3311.130</b>			<b>3311.230</b>			<b>3311.260</b>					
Variant in relation to rack suite	Flush			Flush			Flush					
Rated operating voltage V, Hz	230, 1~, 50/60, 400, 3~, 50/60			230, 1~, 50/60, 400, 3~, 50/60			230, 1~, 50/60, 400, 3~, 50/60					
Dimensions mm	W x H x D			300 x 2000 x 1000			300 x 2000 x 1200			300 x 2000 x 1200		
	Height 2200			On request			On request			On request		
No. of fans in supplied state	1			1			4					
<b>Useful cooling output</b>	<b>10 kW</b>	<b>20 kW</b>	<b>30 kW</b>	<b>10 kW</b>	<b>20 kW</b>	<b>30 kW</b>	<b>40 kW</b>	<b>45 kW</b>	<b>55 kW</b>			
Rated current max.	1	2	3	1	2	3	4	5	6			
Air throughput, max.	4800 m <sup>3</sup> /h with 3 fans			4800 m <sup>3</sup> /h with 3 fans			8000 m <sup>3</sup> /h with 6 fans					
Water inlet temperature	15 °C											
Permissible operating pressure	6 bar											
Duty cycle	100%											
Type of electrical connection	Connector											
Water connection	1 1/2" external thread											
Weight, max.	200 kg	207 kg	214 kg	200 kg	207 kg	214 kg	221 kg	228 kg	235 kg			
Temperature control	Linear fan control											
	Two-way control valve											
Fans may be exchanged with the system operational	yes			yes			yes					
EC fan	■			■			■					
<b>Accessories</b>	Packs of						Page					
Fan module	1	3311.010		3311.010		3311.010	60					
Touchscreen display, colour	1	3311.030		3311.030		3311.030	59					
Connection hose, top	2	3311.040		3311.040		3311.040	59					

■ Included with the supply.

# LCP – Liquid Cooling Package CW



## Benefits:

- Maximum energy efficiency thanks to EC fan technology and IT-based control
- Minimal pressure loss at the air end, which in turn minimises the power consumption of the fans
- Optimum adaptability thanks to dynamic, continuous control of the cold water volume flow
- Using high water inlet temperatures increases the proportion of indirect free cooling, which in turn reduces operating costs
- Targeted cooling output thanks to modular box-type plug-in fan units
- Box-type plug-in fan units

configurable as n+1

- redundancy
- Standard 3-phase connection for electrical redundancy
- With redundant temperature sensor integrated at the air end as standard
- The separation of cooling and rack prevents the ingress of water into the server enclosure
- Up to 55 kW cooling output on a footprint of just 0.36 m<sup>2</sup>
- Minimal area load thanks to low weight
- Touchscreen display may be retrofitted

## Monitoring:

- Monitoring of all system-relevant parameters such as:
- Server air intake temperature

- Server waste air temperature
- Water inlet/return temperature
- Water flow
- Cooling output
- Fan speed
- Leakage
- Optional sensors
- Direct connection of the unit via SNMP over Ethernet
- Integration into RiZone (data centre management software)

## Note:

- Height 2200 mm available on request.
- Photo shows a configuration example with equipment not included in the scope of supply.

## Application and mode of operation:

The LCP is designed for siting

within a bayed enclosure suite. The hot air is drawn in from the room or hot aisle at the rear of the device and expelled at the front into the cold aisle after cooling. The LCP achieves maximum performance and efficiency in conjunction with aisle containment. A raised floor is not required.

## Colour:

- RAL 7035
- Special colours available on request

## Protection category:

- IP 40 to IEC 60 529

## Technical information:

Available on the Internet.

## LCP Inline CW

Cooling medium	Water (see Internet for specifications)								
Model No.	3311.530			3311.540			3311.560		
Variant in relation to rack suite	Set forward			Flush			Set forward		
Rated operating voltage V, Hz	230, 1~, 50/60, 400, 3~, 50/60			230, 1~, 50/60, 400, 3~, 50/60			230, 1~, 50/60, 400, 3~, 50/60		
Dimensions mm	W x H x D 300 x 2000 x 1000			300 x 2000 x 1200			300 x 2000 x 1200		
No. of fans in supplied state	1			2			4		
Useful cooling output	10 kW	20 kW	30 kW	18 kW	25 kW	30 kW	40 kW	45 kW	55 kW
Rated current max.	1	2	3	2	3	4	4	5	6
Air throughput, max.	4800 m <sup>3</sup> /h with 3 fans			4800 m <sup>3</sup> /h with 3 fans			8000 m <sup>3</sup> /h with 6 fans		
Water inlet temperature	15 °C								
Permissible operating pressure	6 bar								
Duty cycle	100%								
Type of electrical connection	Connector								
Water connection	1 1/2" external thread								
Weight, max.	200 kg	207 kg	214 kg	207 kg	213 kg	221 kg	221 kg	228 kg	235 kg
Temperature control	Linear fan control								
	Two-way control valve								
Fans may be exchanged with the system operational	yes			yes			yes		
EC fan	■			■			■		
Accessories	Packs of								Page
Fan module	1	3311.010		3311.010		3311.010		3311.010	60
Touchscreen display, colour	1	3311.030		3311.030		3311.030		3311.030	59
Connection hose, top	2	3311.040		3311.040		3311.040		3311.040	59
Rear adaptor for LCP Inline	1	3311.080		-		3311.080		3311.080	59

■ Included with the supply.

# LCP – Liquid Cooling Package CW



## Benefits:

- Error-tolerant, efficient cooling of server racks with high thermal loads
- Fully redundant – Two active cooling circuits and two switchable power circuits ensure optimum fail-safeness
- The built-in controllers are capable of adapting all device parameters automatically to preserve the required climate conditions

- A separate decentralised intelligence which automatically recognises emergency situations and responds appropriately with the “auto-load balancing” and “auto-recovery” functions
- Interfaces which facilitate userfriendly operation and monitoring via the network or BSM systems

## Optional:

- Fully integrated fire detection and extinguisher system
- Automatic server enclosure door opening
- Various sensors

## Colour:

- RAL 7035

## Protection category:

- IP 40 to IEC 60 529

## Application and mode of operation:

The LCP draws in the air at the sides at the rear of the server enclosures, cools it using highperformance compact impellers, and blows the cooled air back into the front part of the server enclosures at the sides.

## LCP T3+ CW

Cooling medium	Water (see Internet for specifications)
Model No.	3300.239
Rated operating voltage V, Hz	230, 1~, 50/60 400, 3~, 50/60
Dimensions mm	W x H x D 300 x 2200 x 1200
Usable U	42
Useful cooling output, redundant	up to 20 kW
Duty cycle	100%
Type of electrical connection	C19/C20
Temperature control	Linear fan control Two-way control valve
Fans may be exchanged with the system operational	■
EC fan	■
Touchscreen display, colour	■
Connection hose, top	■

■ Included with the supply.

# LCP – Liquid Cooling Package DX



## Benefits:

- Maximum energy efficiency thanks to EC fan technology and IT-based control
- Minimal pressure loss at the air end, which in turn minimises the power consumption of the fans
- Control of the server inlet temperature
- Thanks to the speed-regulated compressor, the cooling output is ideally adapted to actual requirements
- With redundant temperature sensor integrated at the air end as standard

- Absorbed thermal energy is emitted to the ambient air at the external condenser location, without heating up the installation room
- Ideal for IT cooling in small and medium-sized locations
- Humidifier, reheater or condensate pump available on request
- Higher cooling outputs available on request
- Specific maintenance of the LCP DX thanks to separation of cooling and server rack

## Functions of the LCP Rack DX:

The LCP draws in the air at the sides at the rear of the server enclosures, cools it using high-performance compact impellers, and blows the cooled air back into the front part of the server rack at the sides.

## Functions of the LCP Inline DX:

The LCP is designed for siting within a bayed enclosure suite. Hot air is drawn in from the room or hot aisle at the rear of the device, cooled by the high-capacity compact impellers, and blown back into the room or cold aisle after cooling.

## LCP Rack/Inline DX

Installation in bayed enclosure suite	Flush/Rack DX		Flush/Inline DX	
	R410a	R410a	R410a	R410a
<b>Cooling medium</b>	R410a	R410a	R410a	R410a
<b>Model No.</b>	<b>3311.410</b>	<b>3311.420</b>	<b>3311.430</b>	<b>3311.440</b>
Rated operating voltage V, Hz	230, 1~, 50/60 400, 3~, 50/60	230, 1~, 50/60 400, 3~, 50/60	230, 1~, 50/60 400, 3~, 50/60	230, 1~, 50/60 400, 3~, 50/60
Dimensions mm	W x H x D	300 x 2200 x 1000	300 x 2200 x 1200	300 x 2200 x 1000 300 x 2200 x 1200
Number of fans		4	4	4
Air throughput of fans		4800 m3/h	4800 m3/h	4800 m3/h
<b>Cooling output</b>		<b>12 kW</b>	<b>12 kW</b>	<b>12 kW</b>
Duty cycle %		100	100	100
Type of connection (electrical)		Connection clamp	Connection clamp	Connection clamp
Fans may be exchanged with the system operational		■	■	■
EC fan		■	■	■
Colour		RAL 7035 Special colours available on request	RAL 7035 Special colours available on request	RAL 7035 Special colours available on request
Temperature control		Linear fan control Inverter-regulated compressor	Linear fan control Inverter-regulated compressor	Linear fan control Inverter-regulated compressor
Condenser unit		3311.360	3311.360	3311.360
SNMP card		3311.320	3311.320	3311.320

■ Included with the supply.

# Accessories for LCP CW/DX

## Touchscreen display, colour

### for LCP Rack, Inline, CW

The display offers the opportunity of directly monitoring key LCP functions and implementing settings.

For LCP CW	Packs of	Model No.
3311.130	1	3311.030
3311.230		
3311.260		
3311.530		
3311.540		
3311.560		



## Condenser unit

The condenser unit is needed to operate the coolant-based LCPs, and comprises the external condenser and fan. The pipework between the LCP DX and the condenser is not included with the supply.

For LCP DX	Packs of	Model No.
3311.130	1	3311.030
3311.230		
3311.260		
3311.530		
3311.540		
3311.560		



### Coolant:

– R410a

## Vertical shielding

To block the airflow on the left and right of the 482.6 mm (19") level, for enclosure height 2000 mm.

### Coolant:

- Cellular PU foam
- Flame-inhibiting to UL 94 (HF1)
- Length: 1900 mm
- Self-adhesive on one side

For sealing between	For enclosure width mm	Packs of	Model No.
Side panel and 482.6 mm (19") level	600	1	3301.380
	800	1	3301.390
LCP and 482.6 mm (19") level	600	1	3301.370
	600	1	3301.320



## Connection hose, bottom and top

Flexible connection hose, may be cut to required length, including union nuts on both sides for connecting the LCP to existing pipework.

For LCP CW	Thread	Water connection from	Packs of	Model No.
3311.130	1 1/2"	bottom/top	2	3311.040
3311.230				
3311.260				
3311.530				
3311.560				



## Rear adaptor

### for LCP Inline

May be positioned to the rear of the set forward LCP Inline to close the existing gap in the rear section.

For LCP	Packs of	Model No.
3311.530	1	3311.080
3311.560		



# Accessories for LCP CW/DX



## Fan module

### for LCP

To increase the cooling output, individual fan modules may be retro-fitted into the LCPs. Additional integration can also achieve redundancy or reduce the electric power consumption of the LCPs.

For LCP CW	Packs of	Model No.
3311.130, 3311.230, 3311.260, 3311.530, 3311.560	1	<b>3311.010</b>

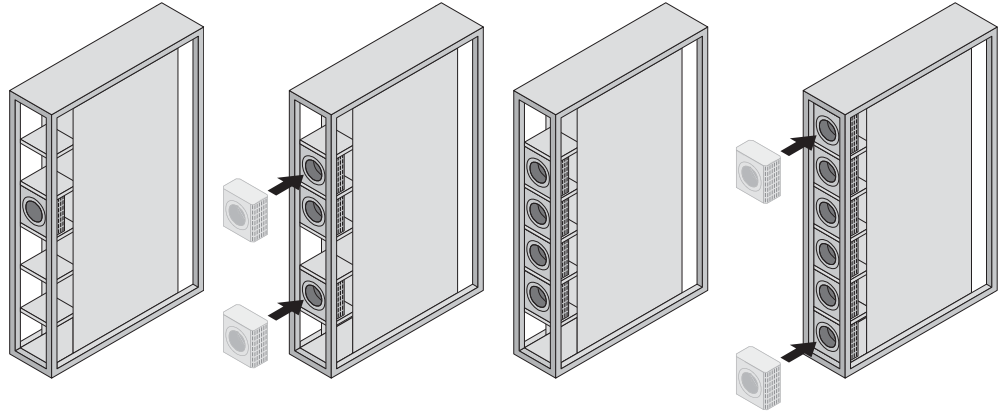

The LCP 3311.130/.230/.530 (max. 30 kW) is supplied with one fan module as standard.

To achieve the max. cooling output of 30 kW, the customer/service needs to install two additional fan modules.

The LCP 3311.260/.560 (max. 55 kW) is supplied with four fan modules as standard.

To achieve the max. cooling output of 55 kW, the customer/service needs to install two additional fan modules.



## Fan module

### for LCP

To increase the cooling output, individual fan modules may be retro-fitted into the LCPs. Additional integration can also achieve redundancy or reduce the electric power consumption of the LCPs.

For LCP CW	Packs of	Model No.
3311.540	1	<b>3311.011</b>

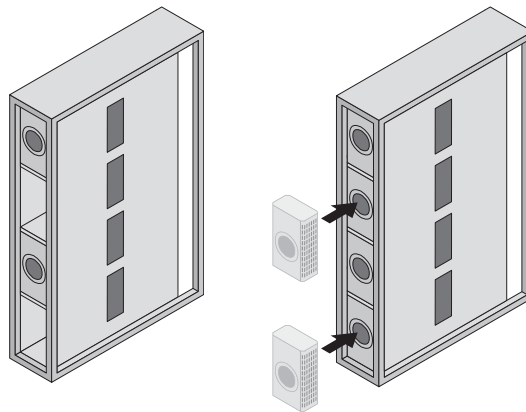

Supplied as standard with two fan modules.

To achieve the max. cooling output, the customer/service needs to install two additional fan modules.

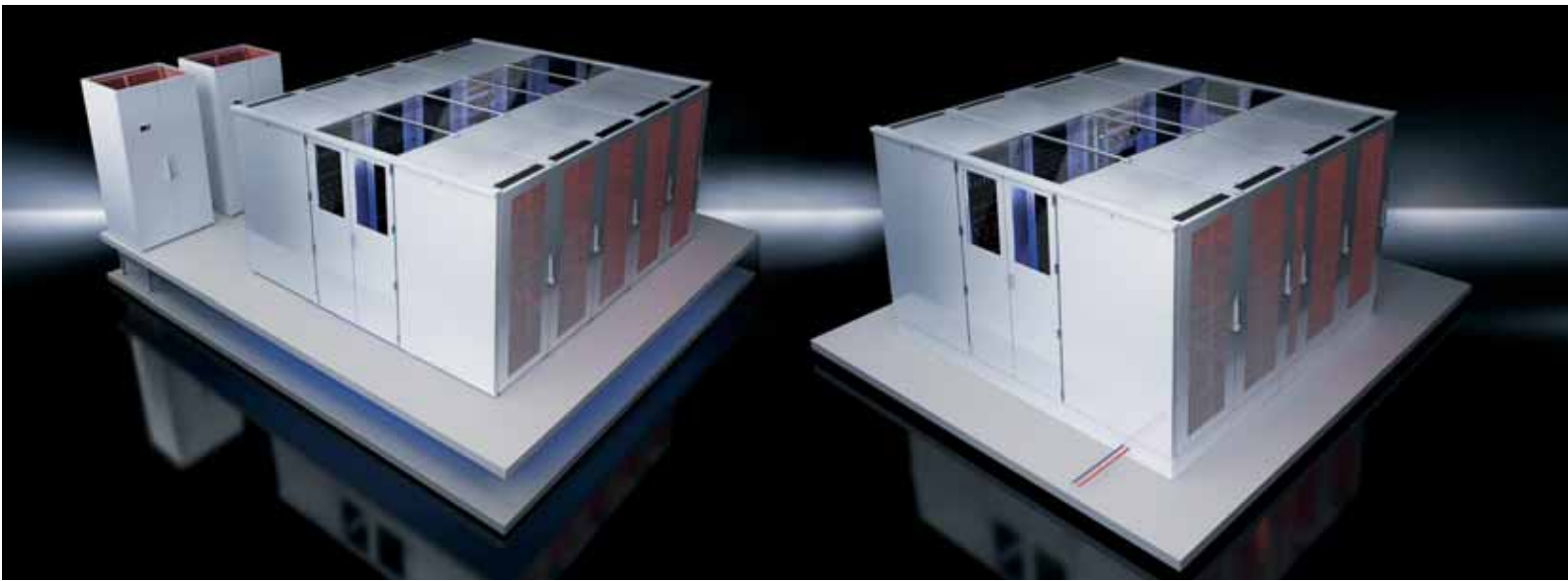

In server rooms that have not been designed as data centres, the permanent mixing of cooled and heated air often leads to cooling deficits. Hot spots make the IT equipment's work more difficult.

In order to efficiently ensure the necessary cooling here, Rittal has developed three cooling variants for aisle containment. Two solutions use containment of the cold aisle. The LCP Inline guides the cooled air directly to the cold aisle at the front, and the CRAC system to the raised floor, so that the cooled air is fed to the cold aisle via perforated raised floor plates. The third solution operates according to the principle of enclosing the hot aisle. The LCP Inline extracts the hot air directly at the point where it is created. The cooling performance of the cooling units is utilised to optimum effect, and the overall efficiency of the system increases significantly.

## Rittal Aisle Containment

- Intake air (cold) and waste air (hot) are unable to mix.
- It is possible to operate at a higher temperature level throughout the entire system.
- The CRAC units operate at maximum efficiency, thanks to the greater temperature difference between the cold and hot air.
- Modular, scalable and upgradable.
- Simple arrangement.
- An inexpensive solution for the optimum cooling of existing data centres.

## Rittal Aisle Containment (Cold Aisle)

### With raised floor

- Use of inexpensive standard CRAC cooling units sited outside of the server area
- Even with low room heights, the raised floor height is maximised for cooling air supply without flow losses
- Undisturbed and uniform air flow distribution of cooling air in the cold aisle guarantees high efficiency
- Favourable working conditions in the cold aisle due to low temperature, flow and noise load conditions
- Hardware racks not connected to the enclosure do not impair the cooling efficiency of the cold aisle

## Rittal Aisle Containment (Cold Aisle)

### Without raised floor

- Direct connection of the liquid cooling packages to an external cold water supply
- Simple laying of pipework in the rack base/plinth
- Homogeneous distribution of cooling air in the cold aisle guarantees a high level of efficiency
- Favourable working conditions in the cold aisle due to low temperature, flow and noise load conditions
- Hardware racks not connected to the containment system do not impair cooling efficiency via the cold aisle
- Room heights play only a minimal role

## Rittal Aisle Containment (Hot Aisle)

### Without raised floor

- Simple assembly using the existing components of Rittal aisle containment
- Direct connection of the Liquid Cooling Packages (LCP Inline) to an external cold water supply
- Simple laying of pipework in the rack base/plinth
- Suitable for use with high heat losses
- Room-neutral dissipation of the heat loss

# IT Chillers



The Rittal IT chiller in conjunction with indirect free cooling supplies media for exceptionally energy and cost-efficient IT cooling. The system is specially designed for supplying critical IT applications cooled via LCP, air/water heat exchangers or CRAC systems.

In this atmospherically sealed system, security options such as redundant, speed-regulated pumps, compressors, emergency cooling or buffer stores ensure optimum operational reliability and fail-safeness.

Alongside optional heat recovery from the system, the connection to the Rittal free cooling recooling systems ensures exceptionally energy-efficient operation. Free cooling uses cold ambient air for cooling, reduces operating costs by up to 80%, extends the service life of components, and increases operational reliability. If the free cooling performance is insufficient, the IT chiller will cut in.

## IT Chiller

- Redundant pumps, speed-regulated
- Redundant scroll compactor
- Intelligent control concept
- Interfaces: SNMP, BACnet
- Integral or separate free coolers (optional)
- Integral automatic bypass valve
- Flow monitor
- Minimisation of operating costs thanks to high water inlet temperatures for LCP and CRAC operation
- High COP (coefficient of performance)
- Integration into RiZone
- 15-480 kW units





**MONITORING**

**SECURITY**

**SERVICE & SUPPORT**

**63**



# CMC III Monitoring System

IT security is now inextricably linked with the Computer Multi Control (CMC) monitoring system – it has become firmly established as a permanent feature of physical IT security, allowing modern IT infrastructures to be operated securely, while at the same time ensuring optimum performance.

The CMC III monitoring system sets new standards with regard to simple assembly and configuration, reduced system complexity, and cost-effectiveness.

In order to be able to cover the wide range of potential applications in IT and industry, the CMC III monitoring system is available in two variants:

## CMC III Processing Unit Compact

The compact monitoring solution for applications in industry and building monitoring or for smaller IT projects with up to four additional CAN-Bus monitoring components.

## CMC III Processing Unit

The powerful, modularly extendible monitoring solution for demanding IT and industrial environments with the option of connecting up to 32 additional monitoring components.

### The benefits to you with both variants:

- Minimal cabling work thanks to bus technology
- Temperature and access sensor, digital inputs and relay output already integrated into the base unit
- Sensors may be connected directly
- Power supply either redundant via two PSUs, directly via 24 V DC with industrial applications, or with Power over Ethernet (PoE)
- Integral OPC server allows direct communication with the control room (BMS or SCADA system)
- Fail-safeness, thanks to CAN-Bus technology. Even if the processing unit should fail, the sensors can still communicate with one another autonomously.



# CMC III Processing Unit/-Compact



## Application areas:

### CMC III Processing Unit Compact:

- Industrial and enclosure monitoring
- Building monitoring
- Small monitoring applications in IT

### CMC III Processing Unit

- Larger monitoring applications in IT and industry

## Material:

Plastic

## Surface finish:

- Front: Smooth
- Enclosure: Textured

## Colour:

- Front: RAL 9005
- Enclosure: RAL 7035

## Protection category:

IP 30 to EN 60 529

## Supply includes:

- Basic system
- Quick-start instructions
- 4 mounting feet

Photo shows a configuration example with equipment not included in the scope of supply.

		CMC III Processing Unit Compact	CMC III Processing Unit
W x H x D mm		138 x 40 (1 U) x 120 + 12 (front assembly)	138 x 40 (1 U) x 120 + 12 (front assembly)
Temperature range		0 °C to +55 °C	0 °C to +55 °C
Operating humidity range		5 % to 95 % relative humidity, non-condensing	5 % to 95 % relative humidity, non-condensing
Sensors/CAN-Bus connection units		max. 4	max. 32
Max. overall cable length for CAN-Bus		1 x 50 m	2 x 50 m
Model No. DK		7030.010	7030.000
Interfaces	Network interface (RJ 45)	Ethernet to IEEE 802.3 via 10/100BaseT with PoE	Ethernet to IEEE 802.3 via 10/100BaseT with PoE
	Front USB interface	Mini USB for system setting	Mini USB for system setting
	Rear USB interface	-	for USB stick for data recording and SW updates up to 32 GB
	Front SD-HC slot	-	x up to 32 GB for data recording
	Rear serial RS232 (RJ 12)	1 x for connecting Display Unit DK 7320.491 or GSM Unit DK 7320.820 or ISDN Unit DK 7320.830	1 x for connecting Display Unit DK 7320.491 or GSM Unit DK 7320.820 or ISDN Unit DK 7320.830
Inputs and outputs	Digital inputs (terminal)	2	2
	Relay output (terminal)	Changeover contact max. 24 V DC, 1 A	Changeover contact max. 24 V DC, 1 A
	CAN-Bus (RJ 45)	1 x for max. 4 sensors (quantity restriction, see Catalogue 33, page 773)	2 x for max. 16 sensors each = 32 sensors in total (quantity restriction, see Catalogue 33, page 773)
	Push-button	1 x acknowledgement button	1 x acknowledgement button
Operation/signals	Concealed reset button	1 x service button	1 x service button
	Piezo signal generator	1 x	1 x
	LED display	1 x multi-colour OK/warning/alarm	1 x multi-colour OK/warning/alarm
	Rear LED	1 x for the network status	1 x for the network status
Protocols	Ethernet	TCP/IPv4, TCP/IPv6, SNMPv1, SNMPv2c, SNMPv3, Telnet, SSH, FTP, SFTP, HTTP, HTTPS, NTP, DHCP, DNS-Server, SMTP, XML, Syslog, LDAP	TCP/IPv4, TCP/IPv6, SNMPv1, SNMPv2c, SNMPv3, Telnet, SSH, FTP, SFTP, HTTP, HTTPS, NTP, DHCP, DNS-Server, SMTP, XML, Syslog, LDAP
Redundant power supply	Input 24 V DC (jack)	1 x for connecting CMC III power pack	1 x for connecting CMC III power pack
	Input 24 V DC (terminals)	1 x for direct connection or for connecting CMC III power pack	1 x for direct connection or for connecting CMC III power pack
	Power over ethernet	1 x	1 x
Functions	Time function	Real-time clock, energy-buffered (24 h) without battery/accumulator, with NTP	Real-time clock, energy-buffered (24 h) without battery/accumulator, with NTP
	User administration	LDAP	LDAP
	User interface	Integral WEB server	Integral WEB server
	Control room connection	Integral OPC server	Integral OPC server
Integral Sensors	Temperature sensor	NTC sensor	NTC sensor
	Access sensor	Infrared technology in the enclosure front	Infrared technology in the enclosure front

# CMC III Sensors/Accessories

## Control units for CMC III Processing Unit

	Model No. DK	PU	PU	Cat 33 Page
		Compact	Maximum quantity	
CMC III I/O Unit, 8 digital inputs + 4 relay outputs	7030.040 <sup>9)</sup>	-	16	581
CMC III power unit, 1 input (C14) + 2 outputs (C13) 230 V, 50/60 Hz	7030.050 <sup>9)</sup>	-	16	581

## CMC III sensors for direct connection

Temperature sensor	7030.110	4	32	-
Temperature/humidity sensor	7030.111	4	32	-
Infrared access sensor	7030.120	4	32	-
Vandalism sensor	7030.130	4	32	-
Analog airflow sensor	7030.140	4	10 <sup>1)</sup>	-
Analog differential pressure sensor	7030.150	4	32	-
Universal sensor (digital input or 4029 mA or S <sub>0</sub> Bus power meter or Wiegand interface)	7030.190	4	32	-

## Interface for CMC III sensors

CMC III CAN-Bus sensor	7030.100	4	32	-
For connecting the following products:				
5 x access sensors (packs of 2), connect a max. of 5 in series	7320.530			-
1 x smoke detector	7320.560			-
1 x motion detector	7320.570			-
1 x voltage monitor 48 V DC	7320.620			-
1 x leakage sensor	7320.630			-
1 x leakage sensor, with sensor length 15 m	7320.631			-
1/3 x fire detector and extinguisher system DET-AC Plus with 3 messages	7338.120			328
1/3 x early fire detection system DET-AC Plus with 3 messages	7338.220			328
1/2 x door control system with 2 enclosure channels	7320.790			589

## Access System

CMC III CAN-Bus Access (with integral infrared access sensor and interface for one reader III)	7030.200	2	16 <sup>1)</sup>	-
For connecting the following products:				
1 x Ergoform-S handle (electro-magnetic)	7320.700			-
1 x Comfort handle TS 8 (electro-magnetic TS 8 handle with master key function, with and without CCP)	7320.721			-
1 x universal lock	7320.730			587
1 x universal handle	7320.950			-
1 x CMC III coded lock	7030.220	2	16 <sup>1)</sup>	-
1 x CMC III transponder reader	7030.230	2	16 <sup>1)</sup>	-

## Interface for PSM, PCU, FCS, DRC

CMC III CAN-Bus Unit for 2 unit channels	7030.030 <sup>9)</sup>	1	4 <sup>2)</sup>	581
For connecting the following products (note: separate supply via power pack possible):				
2 x Fan Control System FCS (DK 7320.812 fan 24 V DC for FCS)	7320.810			587
2 x fan mounting plate DC (universal fan roof W x D 800 x 800 mm with FCS)	7858.488			224
2 x RFID controller DRC	7890.500			597
2 x 4 x Rittal Power Control Unit (PCU) 8-way	7200.001			510
2 x 4 x Rittal Power Control Unit (PCU) C13 LED 8-way	7859.225			510
2 x 4 x socket module active PSM C13 8-way	7856.201			203
2 x 4 x socket module active PSM C13/19 6-way	7856.204			510
2 x 4 x socket module active PSM C13 LED 8-way	7859.222			203
2 x 4 x socket module active PSM C13/19 LED 6-way	7859.232			203
2 x PSM busbar with measurement 16 A	7856.016			202
2 x PSM busbar with measurement 32 A	7856.003			202
2 x PSM measurement module 16 A	7856.019			204

<sup>1)</sup> Max. 5 p. and

<sup>2)</sup> max. 1.p. for power supply with PoE or 48 V power pack.

<sup>3)</sup> Optional attachment see page 585.



# CMC III Accessories



## Power pack 230 V

The CMC III power pack may be integrated into the CMC III assembly unit.

CMC III power pack	Model No. DK
CMC III power pack Input voltage 100 - 240 V 50/60 Hz, output voltage 24 V DC, 2 A	<b>7030.060<sup>1)</sup></b>

<sup>1)</sup> Connection cable/extension required  
D/F/B: 230 V, Model No. DK 7200.210  
C13/C14: 230/115 V, Model No. 7200.215



## Power pack 48 V/ Connection cable 24 V

for CMC III PU, PU Compact/FCS

An alternative power pack is designed for the telecommunications sector (48 V battery voltages) and is connected at the input end via a terminal block. The power pack includes an out cable, 1.65 m long.

### Technical specifications DK 7320.435:

- Rated voltage: 20 - 72 V DC
- Rated current: max. 2.5 A
- Secondary range: 24 V DC, 1.3 A

Primary input voltage	Output voltage	Model No. DK
48 V DC	24 V DC	<b>7320.435</b>

Connection cable for CMC III/FCS for direct connection, provided the 24 V DC supply is available.

Packs of	Length	Model No. DK
1	2 m	<b>7320.813</b>



## Programming cable

The programming cable is required for commissioning of the Processing Unit (PU) or PU Compact.

	Model No. DK
CMC III Programming cable USB	<b>7030.080</b>



## CAN-Bus connection cable

This can be used to connect the PU with the CAN-Bus sensors III, units III, control units III as a bus. Also for cabling together.

Cable	Length	Packs of	Model No. DK
CMC III CAN-Bus connection cable RJ 45	0.5	1	<b>7030.090</b>
CMC III CAN-Bus connection cable RJ 45	1	1	<b>7030.091</b>
CMC III CAN-Bus connection cable RJ 45	1.5	1	<b>7030.092</b>
CMC III CAN-Bus connection cable RJ 45	2	1	<b>7030.093</b>
CMC III CAN-Bus connection cable RJ 45	5	1	<b>7030.094</b>
CMC III CAN-Bus connection cable RJ 45	10	1	<b>7030.095</b>

# CMC III Accessories

## Connection cable/extension

The cable is used to connect to:

- CMC III power pack C 13
- CMC III power unit C 13
- PCU

### Technical specifications:

PVC cable, 3-pole, with IEC connector (non-heating appliances) with contact protection CEE22. Length: at least 1.8 m

Country version	Voltage Volt	Model No. DK
D/F/B/C 13	230	7200.210
IEC 320 device extension C13/C14	230/115	7200.215
Connection cable D/C19	230/115	7200.216
Connection cable C19/C20	230/115	7200.217



## Extension cable

for cable extension of CMC III sensors and FCS fans.

Connector/jack	Length m	Packs of	Model No. DK
RJ 12	5	4	7200.450
RJ 12	1	2	7320.814



## CMC III mounting unit, 1 U

To accommodate PU, PU Compact, control units, CMC III CAN-Bus unit and CMC III power pack.

The mounting unit can accommodate up to 3 units and is secured in the 482.6 mm (19") frame.

	Packs of	Model No. DK
CMC III mounting unit, 1 U	1	7030.070



### Accessories:

Cable clamp strap DK 7610.00, see Catalogue 33, page 535.



## CMC III mounting unit

for enclosure frame

Can accommodate one unit and is mounted on the enclosure frame.

	Packs of	Model No. DK
CMC III mounting unit, enclosure frame	1	7030.071



# CMC III Processing Unit/Compact



Up to 4 CAN-Bus components are supported.<sup>1</sup>

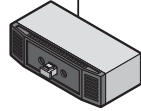

**CMC III sensors:**  
for direct connection

**CMC III CAN-Bus sensor**

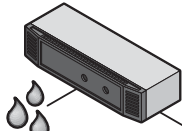

**CMC II sensors**

**CMC III CAN-Bus access**

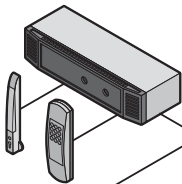

**Mini USB:**

The programming cable DK 7030080 is required for programming.

**Integral sensors:**

- Temperature sensor
- Infrared access sensor

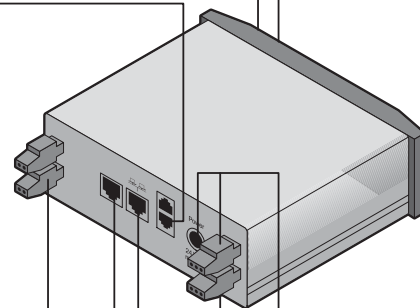

**CMC III Processing Unit Compact**

**Voltage supply 24 V DC and redundant voltage supply 24 V DC**

Power packs/connection cables, see page 57

**Alarm relay output**

Changeover contact for safety extra-low voltage

**Ethernet 10/100 BaseT RJ 45 with PoE:**

Ethernet interface to IEEE 802.3  
Via 10/100 BaseT full-duplex 10/100 Mbit/s

**Accessory modules RJ 12/RS232:**

- Display Unit DK 7320491
- ISDN Unit DK 7320830
- GSM Unit DK 7320820

**Two integral digital inputs**

**CMC III CAN-Bus Unit**

**Interfaces unit for connecting CMC II accessories**

**Connection for other products:**  
see page 60

Contains 2 channels of the PU II Units systems:  
External 24 V DC supply supported.

**Model No. DK 7030030**  
CMC III CAN-Bus Unit

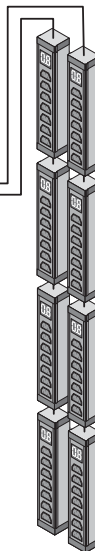

<sup>1</sup> Depending on the power supply/connection combinations, see page 66



# Door Control System

## Door control module

For activation of up to 4 door kits There is 1 control channel available per 2 door kits (e.g. front and rear door). There is optionally a normally closed contact integrated for each door output, which is used to connect the automatic door switch, door comfort handle or a customer specific system (e.g. room extinguisher system).

<b>Model No. DK</b>	<b>7320.790</b>
W x H x D mm	136 x 44 (1 U) x 129
Rated voltage	24 V DC
Door outputs	4 x 24 V DC, 400 mA
Ports for CMC III CAN-Bus unit	2 x RJ 12
Normally closed contacts	Connection must be designed for 30 V DC, 1 A
Temperature application range	+5°C to +45°C
Humidity application range	5% to 95% relative humidity, non-condensing
IP protection category	IP 40 to IEC 60 529



## Door kit

- Fitting a standard door for the Door Control System
- The door kit operates with a gas pressure damper system, allowing the door to be opened in any emergency situation. The doors are kept closed by a magnet system, which unlike mechanical lock systems will release the door in every instance.
- The door kit is connected and activated using the corresponding door control module DK 7320.790.

Version for	Packs of	Model No. DK
2-piece door	1	<b>7320.792</b>
1-piece glazed door	1	<b>7320.795</b>
1-piece sheet steel door	1	<b>7320.796</b>

### Supply includes:

- Gas pressure damper
- Cable harness
- Magnetic lock
- Assembly parts



## Door comfort handle

### with door opener function

By actuating the lock mechanism, the door is released via the automatic door opening system. Prepared for the installation of standard commercially available semi-cylinders, 40 mm, and SZ lock and push-button inserts. Length: 302 mm.

### Technical specifications:

- Rated voltage: 24 V DC
- Rated current: max. 3 A
- Connection cable: Length 3 m
- Temperature application range: +5°C to +40°C

Design	Model No. DK
RAL 7035	<b>7320.794</b>



## Door switch

Switch for connecting to the normally closed contacts of the door control module (DK 7320.790) for manual door opening. It is mounted on the 25 mm pitch pattern of the TS 8 frame section.

### Technical specifications:

- Installation Ø 16.2 mm
- 250 V/2 A

Packs of	Model No. DK
1	<b>7320.793</b>

### Supply includes:

- 3 m connection cable
- Mounting bracket
- Assembly parts



# CMC III Processing Unit/Compact

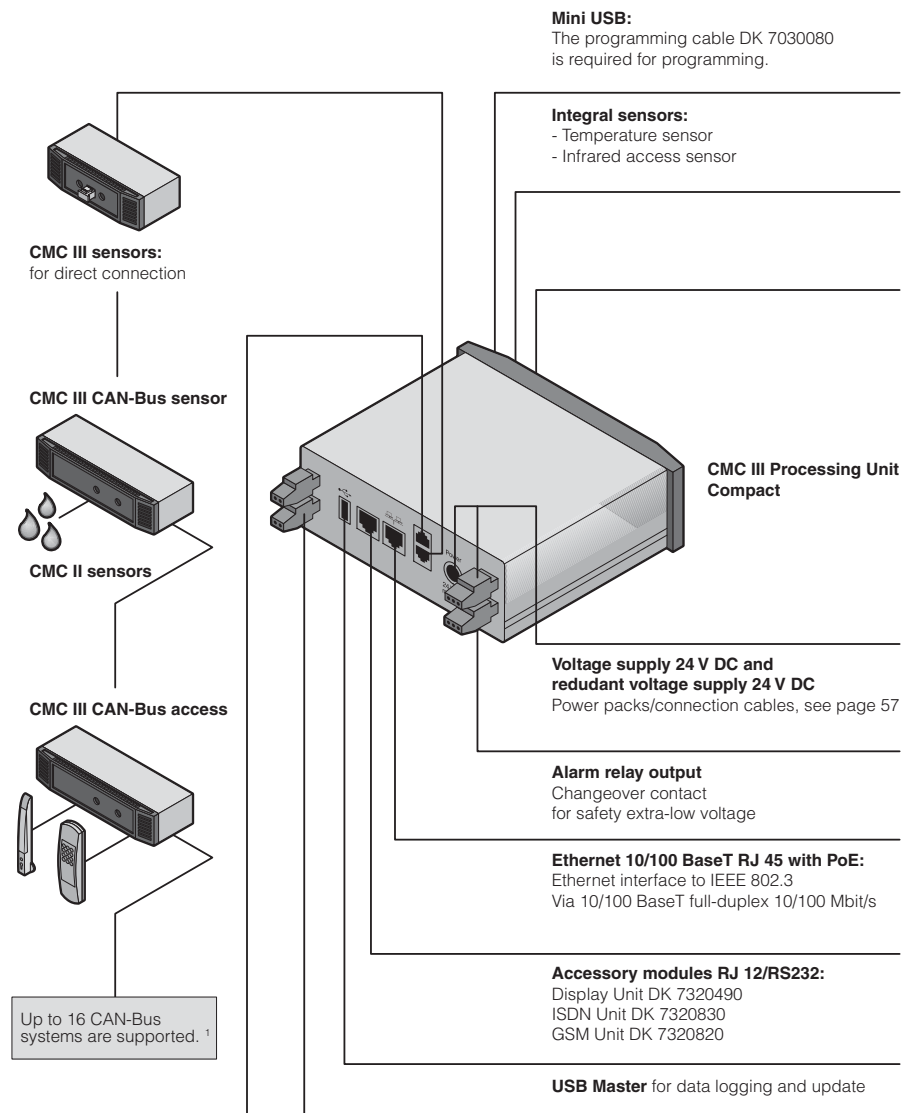

<sup>1</sup> Depending on the power supply/connection combinations, see page 60

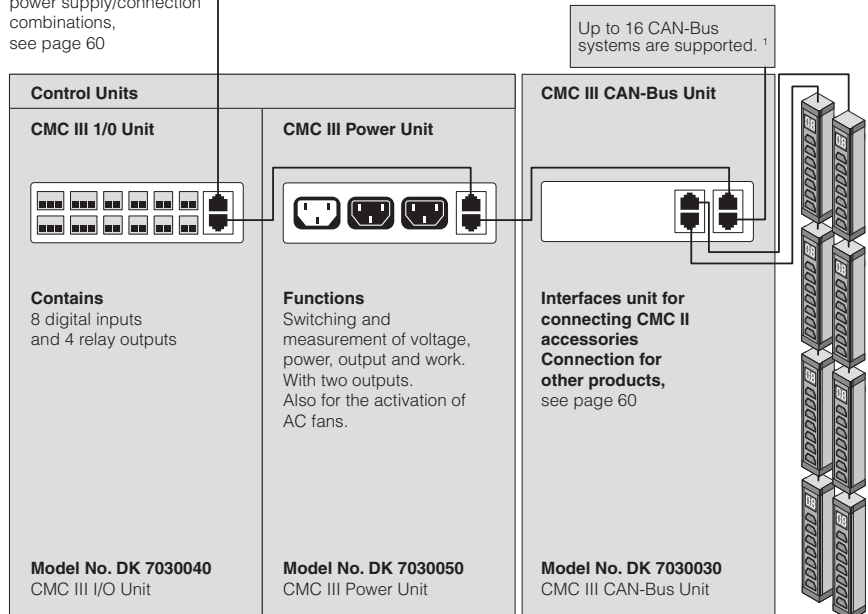

# CMC III Processing Unit/-Compact

## Sample application, CMC III

No.	Model No. DK	
1	7030.010	CMC Processing Unit III Compact (with front infrared access sensor, temperature sensor, 2/1 inputs/outputs)
2	7030.060	Power pack 100 - 240V AC to 24V DC
3	7200.215	Connection cable C13/C14
4	7030.070	Mounting unit, 1 U
5	7610.000	Cable clamp strap
6	7030.080	Programming cable USB
7	7030.090	CAN-Bus connection cable 0.5 m
8	7030.091	CAB-Bus connection cable 1 m
9	7030.093	CAN-Bus connection cable 2 m
10	7030.111	Temperature/humidity sensor
11	7030.120	Access sensor for rear door
12	7030.100	CAN-Bus sensor (CAN adapter for the smoke alarm)
13	7320.560	Smoke alarm

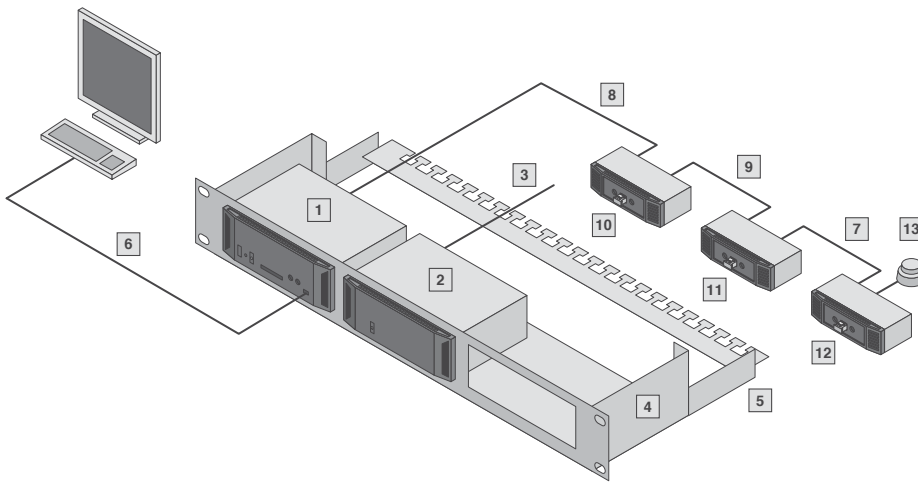

## Monitor/keyboard unit, 1 U with 17" TFT display and VGA/DVI connection

### Benefits:

- High-quality manufacturing
- Analog and digital video input
- Separate numerical keypad
- Optionally with integrated KVM switch for up to 32 server connections in just 1 U
- Low energy consumption
- Simple, one-man installation

### Technical design

- 17" (432 mm) TFT display
- Native resolution 1280 x 1024
- Format 4 : 3
- 16.7 million colours
- Brightness approx. 350 cd/m2 (typ.)
- Contrast ratio approx. 1000: 1
- Mains voltage 100 – 240 V AC, 50 – 60 Hz
- Ambient temperature +5 °C to +45 °C (in operation)
- Max. power consumption in operation, without optional KVM switch: 32 W
- Max. power consumption when closed, without optional KVM switch: < 1 W
- Rear connections: Mains power, VGA, DVI-D, PS/2, USB, power supply for KVM
- Lockable at the front
- Cables are safely routed in the energy chain



### Accessories:

For monitoring several servers:  
KVM switches, see Catalogue 33, page 591.

Width mm	Height U	Depth mm	Installation depth mm	Packs of	Colour	Keyboard	Model No. DK
482.6 (19")	1	680	680-850	1	RAL 7035	German	9055.310
						English	9055.312
					RAL 9005	German	9055.410 <sup>1)</sup>
						English	9055.412 <sup>1)</sup>

Other country-specific versions are available on request.

<sup>1)</sup> Extended delivery times.



# RiZone

RiZone is the management platform for all components in the data centre infrastructure. The system enables the monitoring of redundant data centres (up to Tier IV). RiZone is quickly configured via the automatic recognition of all active Rittal system components, and thanks to a modular licence model is tailored precisely to the requirements of your IT applications.

The administration of the physical infrastructure (from miniature data centres to large, high-MBTf data centres) is efficient, highly flexible and ensures high availability. RiZone can communicate with a server management system (e.g. System Center Operations Manager from Microsoft) and exert direct influence over the availability of individual applications. Only the consistent merging of information from the data centre will allow the availability status of the IT infrastructure to be accurately assessed. With this information, weaknesses can be automatically detected and eliminated.

Rittal RiZone allows energy consumption in the data centre to be adjusted and optimised.

### Your Rittal Benefits

- Optimised availability
- Simplification by reducing complexity
- Enhanced efficiency of the data centre
- Individual representation of the entire IT infrastructure
- Diagrammatic representation of history values
- Calculation of variables such as PUE
- Automatic generation of reports
- Automatic detection of Rittal system components
- Support of the SNMP protocol
- Workflow editor for automated processes
- High-MBTf application
- Link to server management system
- Selectable software or hardware appliance

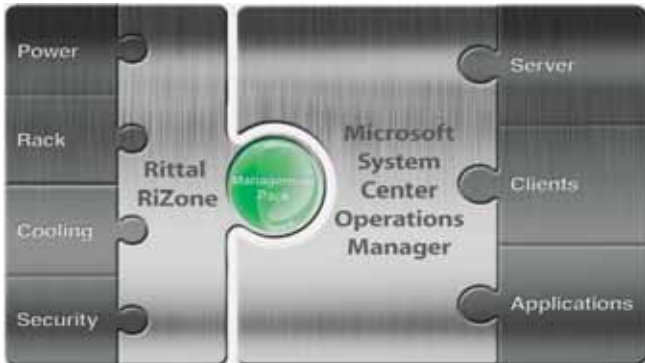

## Efficiency Example

To correspond to the power consumption of your data centre, the cooling output must be designed for maximum performance in unfavourable ambient temperatures. As this diagram of weekly operation shows, unless properly managed, a typical cooling system is oversized most of the time. Here, RiZone saves energy by intelligently adapting the cooling output to the power consumption, airflow and ambient temperature.

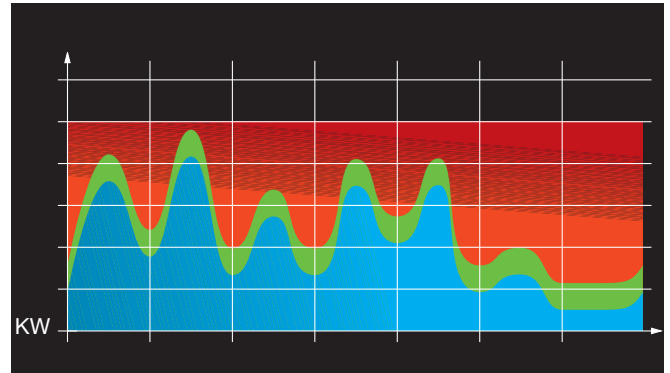

- Sub-optimum cooling output
- Optimum cooling output
- Heat load (IT load)

## The Main Aim Is Availability

Linking the physical data centre infrastructure to server and application management achieves consistent monitoring of the IT services. The early detection of malfunctions allows prompt action to be taken, and ensures compliance with SLAs.

### Live Representation Of The Rack Status

Rittal RiZone supports live, clear representation of the current operating status of a rack. This facilitates reliable monitoring and administration, as well as a fast response in the event of malfunctions and deviations. All key parameters relating to the server rack are incorporated into monitoring; RiZone represents the operating status of the entire rack with the colours red, amber and green.

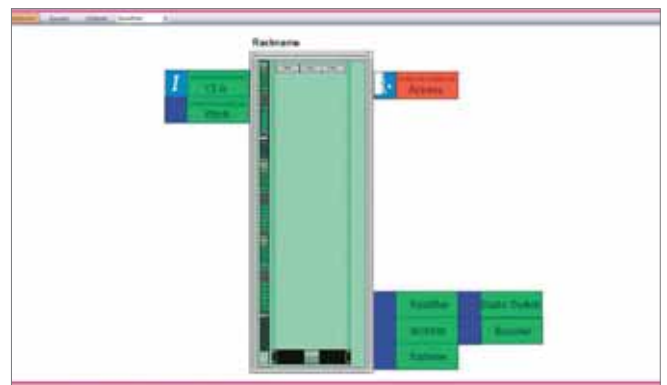

Mindful of availability, rationalisation and future orientation, the physical infrastructure of the IT landscape must be viewed in context. RiZone creates this context! Key for security: Take preventive action! RiZone identifies hot spots on servers or pending phase overloads early on, and responds immediately. This creates peace of mind. Key for resource planning: Identifying trends! Extensions to IT may be implemented transparently using RiZone.

Permanent monitoring supplies clear data on any trend developments, enabling the user to respond promptly to any bottlenecks, and reliably plan the expansion or improvement of the IT infrastructure.

### Key for energy efficiency: Optimise functions!

RiZone represents the energy consumption of individual racks and complete data centres, and supplies the PUE (Power Usage Effectiveness) of all components for energetic optimisation of the data centre.

## RiZone – Simple, Comprehensive And Profitable For Users

- All active Rittal data centre components are automatically detected and administered in the user interface.
- Any components that support the SNMP protocol may be incorporated and are able to use all RiZone functions.
- A workflow editor represents all mathematical operations and configures components comprehensively for optimum linking of all parameters, and therefore offers brand new opportunities for optimising the entire infrastructure.
- Customer-focused licence model: All potential applications – from the server room to the data centre – may be represented.

Be it a “one-rack data centre” or a large “server farm”, protecting the availability of the IT infrastructure is unrelated to the size of the company; RiZone always offers full functionality for controlling and monitoring all IT components. RiZone can be adapted to the size of the company with a flexible licence model.





# IT Security Solutions

## IT Security Rooms And Safes

With Rittal IT security rooms and security safes, we offer a broad spectrum of products for the physical protection of your IT, ranging from basic protection through to high-MTBF protection. The system-tested solutions protect against fire, water, dust, fumes and external access. With the modular room-within-a-room solution, you invest and expand according to your individual requirements, while the option to dismantle and reassemble the system ensures flexibility and protects your investment.

The Rittal complete security solution also includes climate control, power distribution, an uninterruptible power supply, monitoring, fire detection and extinguishing.

### The Benefits To You:

- Protection ranging from basic protection to high-MTBF
- Simple, flexible integration into existing building structures
- Expandability and lasting cost-effectiveness
- Optimum space utilisation, thanks to the flexible modular system
- Flexibility, by enclosing existing IT and infrastructure solutions
- System-tested protection from potential physical threats
- Room-within-a-room concept with the associated depreciation benefits
- Compatibility with Rittal data centre solutions
- High level of pre-manufacturing – fast assembly times
- May be constructed and extended with the IT systems operational
- Plus: The Data Centre Container as a temporary main or backup data centre for outdoor areas

## Fire Alarm And Extinguisher Systems

As well as protecting against potential threats from the environment, the various fire alarm and extinguisher systems focus on identifying and extinguishing a fire inside the data centre. Early fire detection combined with an active extinguisher system prevents the destruction of your IT systems and associated data losses, and therefore safeguards your corporate processes.

LSR 18.6 E high security door system



Secure Airflow Ducts for Direct Free Cooling



LSR18.6 E with 19" racks



LER Extend with Power Distribution / UPS



# IT Security Rooms

The Rittal security rooms LER Basic, LER Extend and LSR 18.6 E allow you to choose between basic protection, extended protection or high-MBTf protection for your data centre. Thanks to the modular

layout of the rooms and the wide range of options available, we will provide you with precisely the protection services your IT needs. The table below provides an insight into the Rittal security room concept.

Criterion	Standards	Conventional design <sup>2</sup>	LSR 18.6 E	LER Extend	LER Basic
System testing	Testing of the following standards as complete system or structure <sup>1</sup>	X	✓	✓	✓
Fire protection Testing at temperatures of up to more than 1,000 °C	ECB-S certifications to EN 1047-2, 50 K temperature increase and 85% rel. humidity up to 24 hours (reheating period), 60 minutes flame impingement time	X	✓	X	X
	50 K temperature rise and 85% rel. humidity over 30 minutes, without reheat period	X	✓	✓	X
	F120 as system test to EN 1363 (DIN 4102), for the cellular structure and its built-in modules	X	✓	X	X
	F90 as system test to EN 1363 (DIN 4102), for the cellular structure and its built-in modules	X	✓	✓	✓
	F180 only as component testing to EN 1363 (DIN 4102), wall system only	X	✓	X	X
	F120 only as component testing to EN 1363 (DIN 4102), wall system only	✓	✓	✓	✓
	F90 only as component testing to EN 1363 (DIN 4102), wall system only	✓	✓	✓	✓
	Explosion	Detonation test as system testing of 200 kg TNT from 40 m	X	✓	X
Water	Standing water, 72 hours, 40 cm, maximum 20 drops	X	✓	X	X
	Extinguisher water, IP x6 as system testing to EN 60529, for the cellular structure and its built-in modules	X	✓	✓	✓
	Relative humidity, 85%, over 24 hours (reheat period), 60 minutes flame impingement time, to EN 1047-2	X	✓	X	X
	Relative humidity, 85%, over 30 minutes	X	✓	✓	X
Dust-tightness	IP 5x as system test to EN 60529, for the cellular structure and its built-in modules	X	✓ <sup>3</sup>	✓	✓
Corrosive fire gases	Acrid gas-tightness, based on EN 1634-3 (DIN 18095)	X	✓	✓	✓
Unauthorised access	WK 3 as system test to EN 1627/1630, for the cellular structure and its built-in modules, such as doors	X	✓	✓	✓
	WK 2 as system test to EN 1627/1630, for the cellular structure and its built-in modules, such as doors	X	✓	✓	✓
	WK 4 only as component testing to EN 1627/DIN 1630, door system only	X	✓	X	X
Falling debris	Shock test as system test, 3 shocks of 200 kg from 1.5 m after 45 minutes flame impingement time	X	✓	X	X
	Shock test as system test, 1 shock of 200 kg from 1.5 m after 30 minutes flame impingement time	X	✓	✓	✓
EMC protection	Protection against high-frequency irradiation and radiation, verified by tests on comparable components by TU Aachen	X	✓	✓	✓
EMC optional package	Extended high-frequency shielding in accordance with BSI TL-03304	X	✓	X	X

<sup>1</sup> System-tested products are tested as a complete construction. This comprises the cellular structure and installation modules such as doors, cable shields or ventilation units. By contrast, component testing only refers to individual parts.

<sup>2</sup> The conventional design refers to room structures of plasterboard, concrete and other standard construction materials which do not offer sufficient protection for data centre applications. Conventional designs are generally tested for use as fire walls.

<sup>3</sup> Tested to EN 60529, category 1 (underpressure).



## Scalable Room Solutions From Rittal

Rittal offers cost-effectively expandable designs and structures, with ecologically and economically optimised data centres offering a host of other benefits:

- Turnkey handover of the data centre
- Scalability – Selection of the most cost-effective solution
- Investment protection thanks to modularity and expandability
- Option of installation with the system operational
- Fast availability

## High-MTBF Protection

As a high-MTBF solution, the Rittal security room LSR 18.6 E offers maximum physical protection for data centres and IT system locations. The system was certified by ESSA (European Security Systems Association) to ECB-S regulations. This certification confirms that the LSR 18.6 E meets the requirements of EN 1047-2 without restriction. Moreover, construction of the security room is subject to constant, independent quality monitoring.

## LSR 18.6 E

- High-MTBF protection for data centres
- High level of pre-production of elements, which reduces dust and noise during assembly
- Fire protection to quality class R60D to EN 1047-2 (fire resistance testing, shock testing, floor testing)
- Protection against external access – Resistance category WK 3, optionally WK 4 based on EN 1627
- Protection against standing water, 72 h, 40 cm, maximum 20 drops
- Explosion testing to SEAP standard
- Extended protection against falling debris
- Dust and water tight to IP 56, category 1 (underpressure) to EN 60529
- Optionally extendible EMC protection to BSI TL-03304

## Benefits Of ECB-S Certification

- Optimum quality protection thanks to independent quality monitoring
- Improvement in the rating situation for loan applications and residual risk insurance
- Transparency for banks and insurance companies
- Compliance with European standards on IT protection

LSR18.6 E for high security data centres

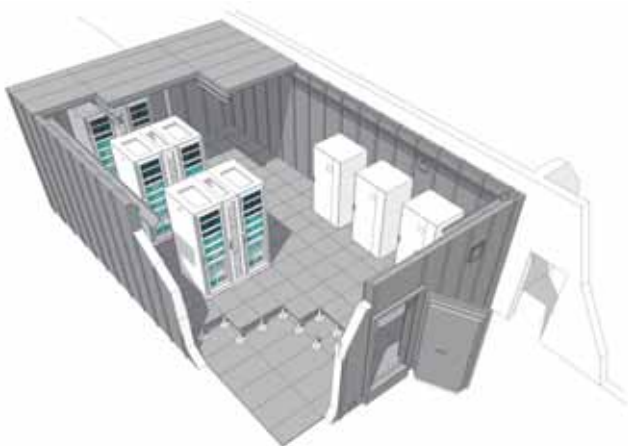

### Standard protection from:



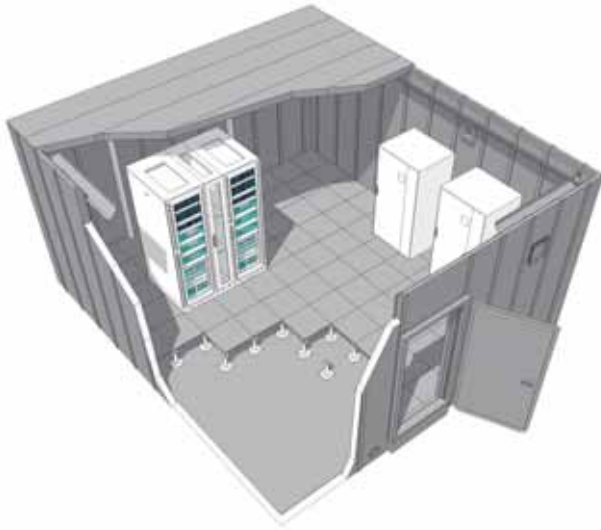

## Basic Protection And Extended Basic Protection

The security rooms LER Basic and LER Extend offer high-quality, system-tested solutions for the basic protection range. As basic and extended solutions, LER Basic and LER Extend are optimum technical rooms for the protection of infrastructure components such as extinguisher systems, uninterrupted power supply etc.

### LER Extend

- Extended basic protection for data centres based on the LER Basic
- Fire resistance testing over 90 minutes – F90, according to the limits of EN 1363 plus compliance with the limits of ECB-S requirements pursuant to EN 1047-2 over 30 minutes

### LER Basic

- Basic protection for data centres or infrastructure solutions
- Fire resistance over 90 minutes – F90 according to the limits of EN 1363
- Dust and water tight to IP 56 to EN 60529
- Protection against external access – Resistance category WK 2, optionally WK 3 based on EN 1627
- EMC protection
- Acrid gas-tightness based on EN 1634-3
- Shock test with 3,000 Nm energy

Standard protection from:



Fire



Extinguishing water



Corrosive gases



Vandalism



Unauthorised access



Electromagn. interference



Dust



Falling debris



Theft/ burglary

LER Extend for infrastructure areas



## Fully System-tested

All Rittal security systems are system-tested. System-tested products are tested as a complete structure, taking into account the interactions between all components. During testing, allowance is made for built-in modules such as doors, cable shielding systems and ventilation units. Benefit from multifunctional risk coverage (fire, water, burglary etc.) and compliance with the latest EN and DIN standards.

# Benefits of Security Safes



- Complete solution in the smallest possible space and in next to no time
- No need for expensive upgrades to existing premises
- Efficient cooling and extinguishing solution

## **Level E modular safe High level of protection for your IT**

- Maximum security in the Rittal range of safes
- Optimum protection concept for one or more server rack solutions for small and medium-sized enterprises
- Modular layout for installation in hard-to-access locations and for retrospective enclosure of existing IT structures
- Future-proof investment thanks to the options of extendibility, dismantling and re-assembly
- System-tested security and a high level of protection; testing has been carried out by accredited institutes and confirmed with test reports
- Modified air baffle plates for optimum air routing, for efficient cooling of the safes

## **Level B modular safe Solid protection for your IT**

- Optimum protection concept for a server rack
- Modular layout for installation in hard-to-access locations
- Form-fit connection with the stable TS 8 framework structure
- Front and rear 482.6 mm (19") level of the TS IT rack already included with the supply
- Lower weight than the Level E modular safe
- Tested security – testing has been carried out by accredited institutes and confirmed with test reports.

## **Level A compact safe Solid protection for small IT applications**

- Ready-installed safe as a complete system
- Integral cooling
- Integral TS 8 frame structure with front and rear pairs of 482.6 mm (19") mounting angles
- Base/plinth with ground clearance
- Tested safety – The tests were carried out as system tests and confirmed via test reports

# Level E Modular Safe



## Applications:

- A high level of protection against potential physical threats for IT
- Targeted configuration components transform the safe into a complete, compact data centre

## Benefits:

- As well as facilitating installation in poorly accessible sites, the modular design also makes it possible to retrospectively enclose existing IT structures.
- Extendibility, dismantling and re-assembly mean targeted, future-safe investments.

- System-tested security and a high level of protection

## Protection standards:

- Fire protection – fire resistance class F 90 to DIN 4102 Part 2
  - Compliance with limit values  $\Delta T < 50$  K, relative humidity 85% for 30 minutes
  - Burglar resistance WK II, III and IV, tool attack analogous to DIN V ENV 1630/1999-04/ WK II
  - Protection category IP 56 to IEC 60 529
  - Smoke protection based on DIN 18 095-2: 1991-03
- The tests were performed as system tests and confirmed with test certificates.

## Material:

- Sheet steel, coated

## Colour:

- Enclosure and service door: RAL 7035
- Operator door: RAL 9005

## Supply includes:

- Security safe with operator door and service door
- Cable entry in both side elements
- Both doors with key lock

## Optional:

- Choice of door hinges
- Bifold doors
- Different cable entry systems
- Cable entry additionally in the top or base unit

- Different lock variants
- Supporting structure

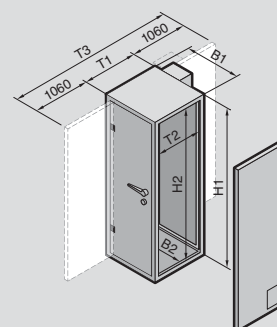

**Technical information:**  
Available on the Internet.

U		42	47	42	47
	External dimensions mm	Width (B1)	1100	1100	1100
Height (H1)		2210	2410	2210	2410
Depth (T1)		1200	1200	1400	1400
Internal dimensions mm	Width (B2)	920	920	920	920
	Height (H2)	2030	2230	2030	2230
	Depth (T2)	1000	1000	1200	1200
Model no. (Safe is configured on a project-specific basis)		<b>7999.009</b>	<b>7999.009</b>	<b>7999.009</b>	<b>7999.009</b>
Empty weight excluding cooling unit and excluding rack approx. kg		660	700	730	800

Accessories					
TS IT rack with air baffle plates	W 600 x H 2000 x D 1000	<b>7995.045</b>	-	-	-
	W 600 x H 2200 x D 1000	-	<b>7995.046</b>	-	-
	W 800 x H 2000 x D 1000	<b>7995.047</b>	-	-	-
	W 800 x H 2200 x D 1000	-	<b>7995.048</b>	-	-
Fire alarm and extinguisher system DET-AC/EFD Plus		see page 90	see page 90	see page 90	see page 90
CMC monitoring system		see page 64	see page 64	see page 64	see page 64
PSM – Power System Module busbar		see page 42	see page 42	see page 42	see page 42
PDU – Power Distribution Unit		see page 39	see page 89	see page 39	see page 39
Split cooling solutions		from page 87	from page 87	from page 87	from page 87
LCP – Liquid Cooling Package, rack depth 1000 mm		see page 48	see page 48	see page 48	see page 43

## Standard protection from:



Fire



Extinguishing water



Corrosive gases



Vandalism



Unauthorised access



Dust



Theft/burglary

# Options for Level E Modular Safe

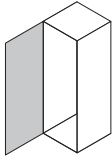
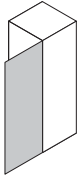
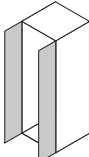
<b>Operator door</b>	L/h DIN door hinge	R/h DIN door hinge	Bifold door
			
	<input checked="" type="checkbox"/>	<input type="checkbox"/>	<input type="checkbox"/>

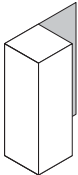
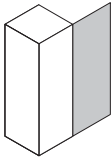
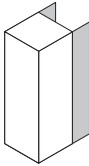
<b>Service door</b>	L/h DIN door hinge	R/h DIN door hinge	Bifold door
			
	<input checked="" type="checkbox"/>	<input type="checkbox"/>	<input type="checkbox"/>

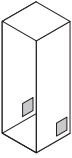
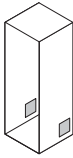
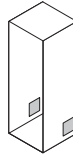
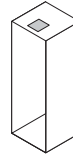
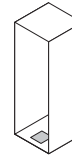
<b>Cable entry</b>	Soft duct <sup>1)</sup> in both side elements	Hard duct <sup>2)</sup> in both side elements	Cable box <sup>3)</sup> in both side elements	Hard duct <sup>2)</sup> in top element	Hard duct <sup>2)</sup> in base element
					
	<input checked="" type="checkbox"/>	<input type="checkbox"/>	<input type="checkbox"/>	<input type="checkbox"/>	<input type="checkbox"/>

<sup>1)</sup> Size of soft duct: approx. 267 x 165 mm  
For fire protection reasons, the duct may be configured up to a max. of 60% with cable up to a diameter of 15 mm and conduits up to a diameter of 18 mm.

<sup>2)</sup> Size of hard duct: 2 panels each 120 x 120 mm

<sup>3)</sup> Size of cable box: Cables up to a diameter of 15 mm and hoses up to a diameter of 44 mm may be routed through the cable box. No conduits may be routed through the cable box.

<b>Locks</b>	Key lock with 2 keys	Electronic combination lock <sup>1)</sup>	Electronic combination lock for activation via an access control system supplied by the customer
	<input checked="" type="checkbox"/>	<input type="checkbox"/>	<input type="checkbox"/>

<sup>1)</sup> First code, second code and double code allocation possible. Key-based opening for inspection purposes supported.

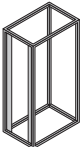
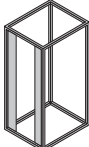
<b>TS IT rack with air baffle plates</b>								
	600				800			
Width mm								
Height mm	2000	2200	2000	2200	2000	2200	2000	2200
Depth mm	1000	1000	1200	1200	1000	1000	1200	1200
Model No.	7995.045	7995.046	On request		7995.047	7995.048	On request	
	<input type="checkbox"/>	<input type="checkbox"/>	<input type="checkbox"/>	<input type="checkbox"/>	<input type="checkbox"/>	<input type="checkbox"/>	<input type="checkbox"/>	<input type="checkbox"/>

■ Included with the supply □ Optional

<b>Supporting structure</b>	Steel supporting structure to compensate for the raised floor height when siting the modular safe on the bare floor. The height of the supporting structure is selectable between 100 mm and 1000 mm.	Steel supporting structure to compensate for the raised floor height when siting the modular safe on the bare floor. The supporting structure has a fire-proof covering. The height of the supporting structure is selectable between 100 mm and 1000 mm.
	<input type="checkbox"/>	<input type="checkbox"/>

■ Included with the supply

□ Optional



# Level B Modular Safe



### Applications:

- Basic protection against potential physical threats for IT components. Targeted configuration components transform the safe into a complete, compact data centre.

### Benefits:

- Modular layout for installation in hard-to-access locations
- Lower weight than the Level E modular safe
- Tested security – testing has been carried out by accredited institutes and confirmed with test reports.

### Protection standards:

- Fire protection – fire resistance class EI 90/F 90 to DIN EN 1363-1: 1999 based on DIN EN 4102-2: 1997
- Burglar resistance RC 2, tool attack analogous to DIN EN 1630/2011-09/RC 2
- Smoke protection based on DIN EN 18 1634-3: 2005-01
- Protection category IP 56 to IEC 60 529: 2000

### Material:

- Sheet steel, coated

### Colour:

- Enclosure and rear door: RAL 7035
- Operator door: RAL 9005

### Supply includes:

- Security safe with integral TS 8 frame
- Front and rear 482.6 mm (19") level
- Adjusted air baffle plates
- Every side element is prepared for one cable entry at the bottom and one cable entry at the top
- Operator and service door with swing-lever handle and semi-cylinder

### Optional:

- Choice of door hinges
- Bifold doors
- Different cable entry systems
- Cable entry additionally in the

- top and base element
- Different lock variants
- Supporting structure with fire protection

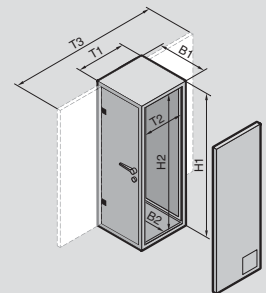

**Technical information:**  
Available on the Internet.

U		42	47	42	47
External dimensions mm	Width (B1)	1115	1115	1115	1115
	Height (H1)	2205	2405	2205	2405
	Depth (T1)	1353	1353	1553	1553
	Depth (T3)	3274	3274	3474	3474
Internal dimensions mm	Width (B2)	900	900	900	900
	Height (H2)	2000	2200	2000	2200
	Depth (T2)	1060	1060	1260	1260
Model no. (Safe is configured on a project-specific basis)		<b>7999.709</b>	<b>7999.709</b>	<b>7999.709</b>	<b>7999.709</b>
Empty weight excluding cooling unit approx. kg		595	630	660	700

### Accessories

Fire alarm and extinguisher system DET-AC/EFD Plus	see page 90	see page 90	see page 90	see page 90
CMC monitoring system	see page 64	see page 64	see page 64	see page 64
PSM – Power System Module busbar	see page 42	see page 42	see page 42	see page 42
PDU – Power Distribution Unit	see page 39	see page 39	see page 39	see page 39
Split cooling solutions	from page 87	from page 87	from page 87	from page 87
LCP – Liquid Cooling Package, rack depth 1000 mm	see page 48	see page 48	see page 48	see page 48

### Standard protection from:



Extinguishing water



Corrosive gases



Vandalism



Unauthorised access



Dust



Theft/burglary

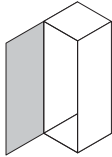
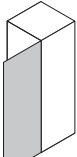
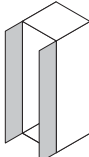

# Options for Level B Modular Safe

Operator door	L/h DIN door hinge	R/h DIN door hinge	Bifold door
			
	<input checked="" type="checkbox"/>	<input type="checkbox"/>	<input type="checkbox"/>

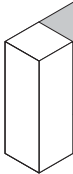
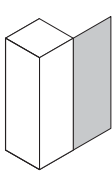
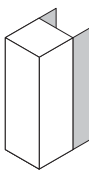

Service door	L/h DIN door hinge	R/h DIN door hinge	Bifold door
			
	<input checked="" type="checkbox"/>	<input type="checkbox"/>	<input type="checkbox"/>

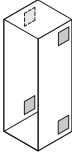

Cable entry	Soft duct <sup>1)</sup> in both side elements	Cable box <sup>2)</sup> in top element	Cable box <sup>2)</sup> in base element	Cable box <sup>2)</sup> in both side elements
				
	<input checked="" type="checkbox"/>	<input type="checkbox"/>	<input type="checkbox"/>	<input type="checkbox"/>



<sup>1)</sup> Size of soft duct: approx. 267 x 165 mm  
For fire protection reasons, the duct may be configured up to a max. of 60% with cable up to a diameter of 15 mm and conduits up to a diameter of 18 mm.

<sup>2)</sup> Size of cable box: Cables up to a diameter of 15 mm and hoses up to a diameter of 44 mm may be routed through the cable box. No conduits may be routed through the cable box.

Locks	Swing lever handle with interchangeable semi-cylinder	Swing lever handle with electronic lock for external activation	Swing lever handle with electronic lock with combination code
		<input checked="" type="checkbox"/>	<input type="checkbox"/>



Supporting structure	Steel supporting structure to compensate for the raised floor height when siting the modular safe on the bare floor. The supporting structure has a fire-proof covering. The height of the supporting structure is selectable between 100 mm and 1000 mm.		
		<input type="checkbox"/>	<input type="checkbox"/>

- Included with the supply
- Optional

# Level A Compact Safe



## Applications:

- Protection for servers and storage applications
- Protection for business-critical data
- Storage of personal data, e.g. doctors' surgeries or tax advisors

## Benefits:

- Complete system with built-in cooling and 482.6 mm (19") rack
- High level of operational and service-friendliness thanks to the two-door system
- Compatibility with other infrastructure elements

## Protection standards:

- Fire resistance class F 90 to DIN 4102 Part 2, compliance with limits  $\Delta T < 50$  K, rel. humidity  $< 85\%$  over 10 minutes
- Burglar resistance WK II, tool attack analogous to DIN V ENV 1630/1999-04/WK II
- Protection category IP 55 to IEC 60 529

The tests were performed as system tests and confirmed with test reports.

## Material:

- Sheet steel, coated

## Colour:

- Enclosure and service door: RAL 7035
- Operator door: RAL 9005

## Supply includes:

- Security enclosure with operating and service doors (three-point locking)
- Cable entry in both side elements
- Cooling 2.4 kW designed as a split unit

## Technical information:

Available on the Internet.

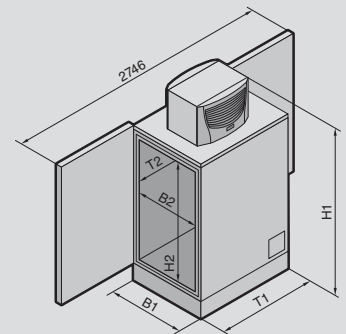

<b>U</b>		15
Cooling capacity kW		2.4
<b>External dimensions mm</b>	Width (B1) mm	806
	Height (H1) mm	1699
	Depth (T1) mm	1270
<b>Internal dimensions mm</b>	Width (B2) mm	620
	Height (H2) mm	827
	Depth (T2) mm	1024
Weight excluding internal fittings, including climate control unit approx. kg		360
<b>Model No. Basic Safe with built-in 482.6 mm (19") rack</b>		<b>7999.999</b>
<b>Model No. Basic Safe without built-in 482.6 mm (19") rack</b>		<b>7999.898</b>
<b>Accessories</b>		
482.6 mm (19") rack, 15 U, depth 1000 mm		7995.992
Fire alarm and extinguisher system DET-AC/EFD Plus		see page 90
CMC monitoring system		see page 64
PDU – Power Distribution Unit with busbar		see page 39

## Standard protection from:



Fire



Extinguishing water



Vandalism



Unauthorised access



Dust



Theft/burglary



# Compact Split Cooling Solution for Modular Safes



- The individual systems all have separate, hermetically sealed internal and external circuits. This means that dust and flue gases are unable to ingress the modular safe via the cooling system. The internal and external unit are connected to one another via coolant lines and control cables and shielded for fire protection.
- Air routing inside the safe is horizontal. Modified air baffle plates ensure targeted air routing. By separating the

“cold side” from the “hot side”, air short-circuits are avoided, and the efficiency of cooling is enhanced. The compact split cooling solutions are suitable for use in rooms with climate control in the building or adequate ventilation, and low or no noise level requirements. The evaporator coil is fastened to the side panel on the inside of the modular safe, and the external device on the service door.

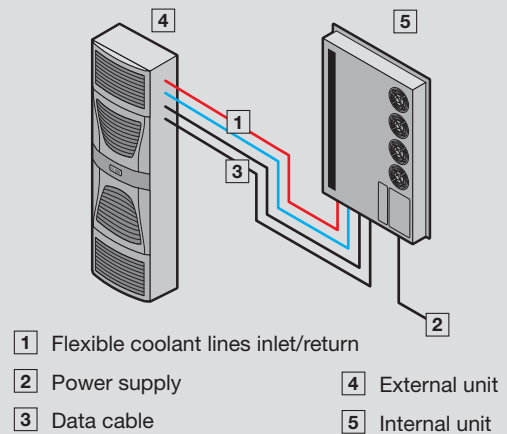

Model No.		3126.230	3126.240
Rated operating voltage V, Hz		400/460, 3~, 50/60	
Dimensions mm	W x H x D external unit	500 x 1580 x 231	
	W x H x D internal unit	804 x 1544 x 100	
Useful cooling output $\dot{Q}_k$ to DIN 3168	L 35 L 35	2500 W/3090 W	4000 W/4010 W
	L 35 L 50	2070 W/2300 W	3020 W/3250 W
Rated current max.		3.3 A/3.5 A	4.1 A/4.8 A
Start-up current		14.2 A/14.7 A	15.2 A/15.8 A
Pre-fuse T		6.3 – 10.0 A	6.3 – 10.0 A
Motor circuit-breaker		■	■
Power consumption $P_{el}$ to DIN 3168	L 35 L 35	1275 W/1615 W	1620 W/2125 W
	L 35 L 50	1525 W/1920 W	1825 W/2835 W
Refrigeration factor $e = \dot{Q}_k/P_{el}$	L 35 L 35	2.0	2.5
Refrigerant		R134a, 1500 g	R134a, 2900 g
Permissible operating pressure p. max.		28 bar	25 bar
Temperature and setting range		+20 °C to +55 °C	+20 °C to +55 °C
Noise level dB (A)		< 70	< 72
Protection category to IEC 60 529	Internal circuit	IP 54	IP 54
	External circuit	IP 24	IP 24
Weight	External unit	65 kg	65 kg
	Internal unit	70 kg	70 kg
Colour		RAL 7035	RAL 7035
Temperature control		Comfort controller (factory setting +25 °C)	

# Split Outdoor Cooling Solution for Modular Safes



– When using the outdoor variant, the internal circuit of the cooling unit is secured to the side panel on the inside of the safe. The external unit is positioned outside of the building. The internal and external units are connected to one another via coolant lines and control cables. The hot air from the servers is drawn in at the rear of the safe, and the cooled air is expelled in front of the 482.6 mm (19") level. Benefits of the outdoor model: The waste heat is routed directly to the outside. As a result, room ventilation or air-conditioning is not necessary.

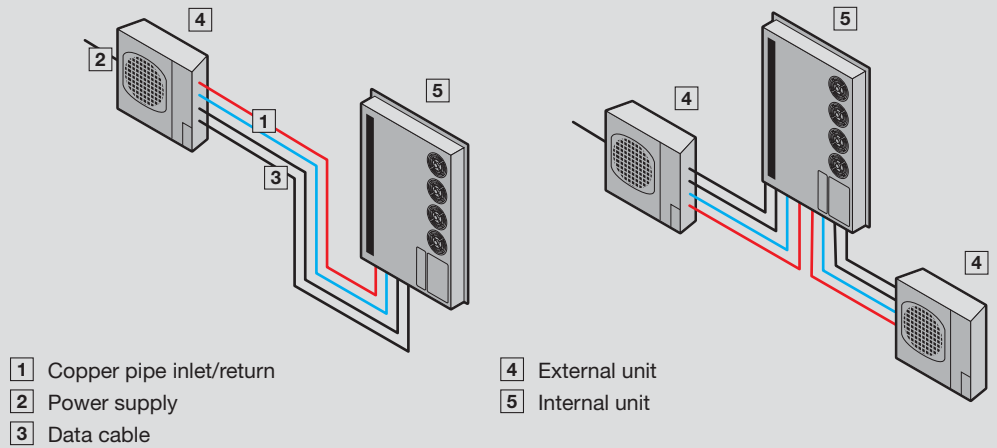

Model No.	7999.963	7999.965	7999.964	7999.966
Redundancy	–	–	■	■
Rated operating voltage V, Hz	230 V, 50 Hz, 1~	400 V, 50 Hz, 3~	230 V, 50 Hz, 1~ (2 x)	400 V, 50 Hz, 3~ (2 x)
Dimensions of external unit, mm	W x H x D 795 x 610 x 290	900 x 680 x 340 (2 x)	795 x 610 x 290	900 x 680 x 340 (2 x)
Useful cooling output $\dot{Q}_k$ to DIN 3168	L 35 L 35 2400 W	5000 W	2400 W	5000 W
Rated current max.	3.8 A	4.1 A	3.8 A	4.1 A
Start-up current per unit	19.5 A	35 A	19.5 A	35 A
Pre-fuse T	16 A	3 x 16 A	16 A (2 x)	3 x 16 A (2 x)
Refrigerant	R410 a			
Temperature and setting range	–15 °C to +35 °C			
Weight	External unit	38 kg	74 kg	2 x 38 kg
	Internal unit	59 kg	59 kg	63 kg
Colour	RAL 7035			
<b>Accessories</b>				
Coolant line incl. electric control cable for 2400 W, length 20 m	7999.961	–	7999.961	–
Coolant line incl. electric control cable for 5000 W, length 20 m	–	7999.962	–	7999.962

# Split Outdoor Cooling Solution with Inverter Technology



– The cooling unit with inverter technology allows targeted speed control of the compressor. The coolant volume is regulated via the electronic expansion valve. Adaptation to cooling requirements facilitates energy savings of up to 40%. The cold air is expelled in front of the 482.6 mm (19") level by the internal unit (evaporator coil), while the hot air is drawn in at the rear.

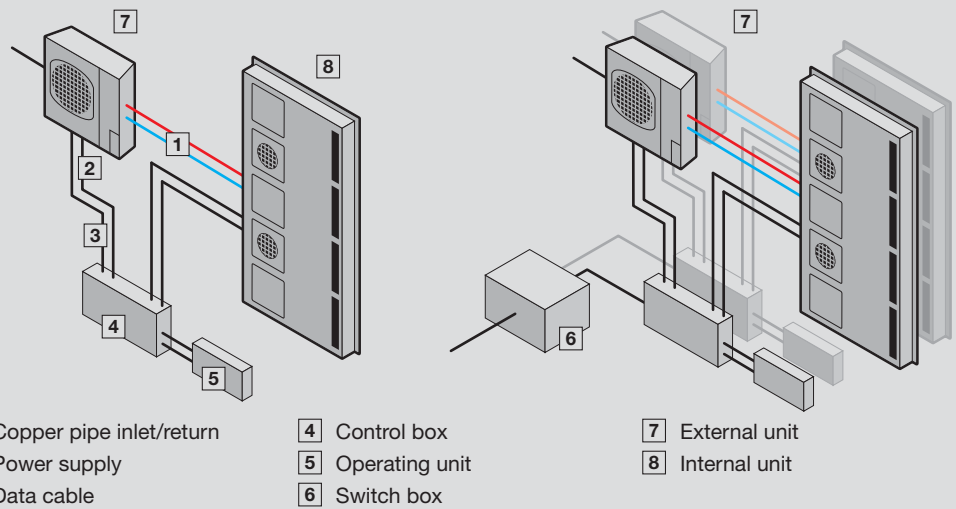

Model No.	7999.991	7999.992
Redundancy	–	■
Rated operating voltage V, Hz	230 V, 50 Hz, 1~	230 V, 50 Hz, 1~ (2 x)
Dimensions of external unit, mm	W x H x D 900 x 795 x 320	900 x 795 x 320 (2 x)
Useful cooling output $\dot{Q}_k$ to DIN 3168	L 18 <sup>1)</sup> /L 35 L 18/L 43 7850 W 7030 W	7850 W 7030 W
Rated current max.	13.9 A	13.9 A
Start-up current	36 A	36 A
Pre-fuse T	25 A	25 A (2 x)
Refrigerant	R 410a	R 410a
Temperature and setting range	–15 °C to +43 °C	–15 °C to +43 °C
Noise level	48 – 49 dB (A)	48 – 49 dB (A)
Weight	External unit Internal unit 63 kg 70 kg	63 (2 x) kg 70 (2 x) kg
Colour	RAL 7035	
<b>Also required</b>		
Heat exchanger (evaporator coil)	3126.270	3126.270 <sup>2)</sup>

<sup>1)</sup> Server inlet temperature

<sup>2)</sup> 2 heat exchangers are required.

# Fire Alarm and Extinguisher System DET-AC/EFD Plus



## Applications:

- Early fire detection
- Automatic extinguishing
  - Innovative extinguisher gas NOVEC 1230
  - Eco-friendly
  - Uncritical for IT components
- 482.6 mm (19") rack mount with just 1 U

## DET-AC Plus

Compact fire alarm and active extinguisher system with smoke extraction system, built into one height unit. The detection system is identical to that used in the EFD Plus system. Fire extinguishing with the extinguisher gas NOVEC 1230 is automatically activated when a main alarm is triggered. With the extinguisher gas supply provided, a volume of up to 3 m<sup>3</sup> can be extinguished. The collective fault signal and the alarms may be forwarded to the CMC.

## DET-AC Plus slave

In conjunction with the DET-AC Plus system, up to five bayed enclosures may be extinguished. In addition to the DET-AC Plus unit, a DET-AC Plus slave unit is used for each additional enclosure and contains the extinguisher gas for one enclosure. The pipework from the DET-AC Plus system is laid in all enclosures to facilitate detection.

## EFD Plus

Compact early fire detection system with active smoke extraction system. The integral fan continuously extracts the air from the enclosure, and passes it over two smoke detectors. The first smoke detector is extremely sensitive and triggers a pre-alarm. The second smoke detector triggers the main alarm.

	Fire alarm and extinguisher system DET-AC Plus	Add-on unit DET-AC Plus slave	Early fire detection system EFD Plus
<b>Width (B) mm</b>	482.6 (19" rack mount)	482.6 (19" rack mount)	482.6 (19" rack mount)
<b>Height (H) mm</b>	44 (1 U)	44 (1 U)	44 (1 U)
<b>Depth (T) mm</b>	640	570	500
Weight kg	approx. 15	approx. 12	approx. 8
<b>Model No.</b>	<b>7338.120</b>	<b>7338.320</b>	<b>7338.220</b>
Protection category	IP 20	IP 20	IP 20
Ambient temperature (operation)	+10 °C to +35 °C	+10 °C to +35 °C	+10 °C to +35 °C
Battery storage	-10 °C to +50 °C	-10 °C to +50 °C	-10 °C to +50 °C
Operating voltage	100/240 V AC 50/60 Hz	24 V DC	100/240 V AC 50/60 Hz
Uninterruptible mains electricity operation	2 x 12 V; 2.2 A/approx. 4 h	2 x 12 V; 2.2 A/approx. 4 h	2 x 12 V; 2.2 A/approx. 4 h
Connections	3 RJ 12 connectors for connecting to the CMC, alternatively 3 relay outputs, max. contact load 24 V DC/0.5 A		
Sensors	2 different scattered-light sensors	–	2 different scattered-light sensors
Display	LCD display with plain text information	–	LCD display with plain text information
No. of slave modules	max. 4	–	max. 5
No. of monitored enclosures	max. 5	–	max. 5
Extinguisher gas	NOVEC 1230	NOVEC 1230	–
Fill volume of extinguisher gas	3.2 kg	3.2 kg	–
Admissible max. protection volume	3 m <sup>3</sup>	3 m <sup>3</sup>	–
<b>Also required</b>			
Pipe kit	<b>7338.130</b>	<b>7338.130</b>	<b>7338.130</b>
RJ 12 cable for alarm relaying to CMC, packs of 2	7320.814 <sup>1)</sup>	7320.814 <sup>1)</sup>	7320.814 <sup>1)</sup>
Access sensors	7320.530	7320.530	–
Depth-variable slide rails	–	–	5501.480

<sup>1)</sup>2 packs are required.



## Data Centre Construction

- Engineering & design to implement complete data centres
- Site management and execution as general contractors
- Project and process management of the entire workflow
- Handling of all licensing procedures (construction application, statics and other approvals)

- Preparation of various certifications, including the relevant international certificates (safety, energy efficiency, availability)

## IT Infrastructures

- Standardised server racks and network enclosures
- Scalable IT cooling concepts
- Modular power distribution and backup
- High-MTBF IT security rooms, including certificates
- Complete system accessories for IT environments and data centres
- Software-based IT and infrastructure management system

Rittal drafts, plans and implements high-MTBF data centres and IT environments that are super-efficient in every respect.

Based on your requirements, our engineers and expert planners will devise optimised, perfectly functioning IT centres for every size of company. This means that you only have one project partner: Rittal.

As general contractors, site managers and your point of contact, we will coordinate the complex work operations on your behalf. With our supremely well-organised process and project management system, we will reduce interfaces, coordinate the various works, clarify your detailed questions on site, and strictly adhere to the agreed timetables. The finished outcome will be a perfect, turnkey data centre complete with all components: Server racks, network enclosures, power distribution, climate control, efficiency management and the necessary monitoring and security components. Upon request we will also take care of your security and energy efficiency certifications (e.g. TÜV-ITIER) and appropriate emergency planning concepts.

Only infrastructures with coordinated components will achieve full performance in the long term. Rittal incorporates this into the planning stage, and you will reap the benefits with regard to implementation and service. You will receive modular, scalable solutions from a single source – cooling, power, security room, monitoring, management and service. “Rittal – The System. Faster – better – worldwide.”

The components we have selected for you are tried and tested, thereby reducing any required adjustments between equipment and solutions from possible external suppliers to a bare minimum. As a complete supplier, we will also optimise the interactions between hardware and individual data centre software on your behalf in the following areas: Settings, monitoring, process optimisation, efficiency control, emergency messages, maintenance etc. With our global, solid experience and broad product portfolio, we will create a secure, highly efficient basis for your entire IT infrastructure. You will benefit immediately from maximum performance capability, combined with permanent reliability, stability and availability.

*Rittal endorses the European Code of Conduct and strives consistently to achieve its goals.*

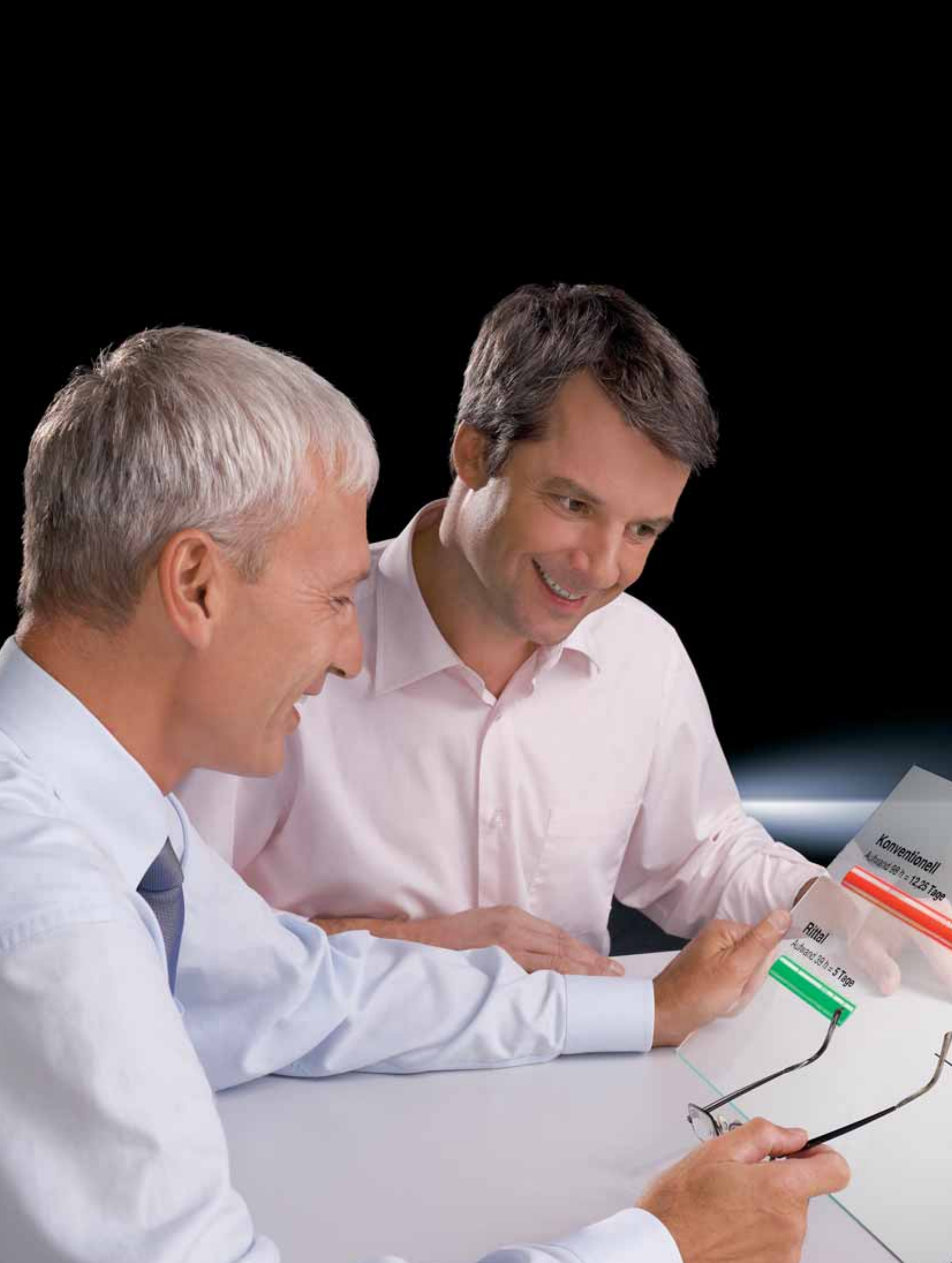

“Rittal – The System. Faster – better – worldwide.” means innovative strength plus IT expertise plus decades of experience, all from a single source. Thanks to our intelligently compiled portfolio of solutions, we will continuously supply you with ideas, concepts, innovations and the exact IT solution you need for your company, right from day one. With Rittal, you can commit to high-end solutions: Engineering & consulting, data centre construction, IT infrastructures, and the international Rittal service. Utilise the knowledge, experience and products of a successful global player, for yourself and your IT.

Rittal develops and optimises individual ITC solutions on your behalf, from small IT units to complex data centres. Our specialists will precisely analyse the current status and future requirements, the structural and physical conditions, and the existing IT structures, and on this basis will tap into proven optimisation potential. This will facilitate the planning and implementation of IT systems with maximum efficiency in terms of performance, costs, processes, energy input, compatibility, availability and security. Rittal’s technical and detailed planning teams will conduct all the necessary analyses and calculations, prepare all the drawings and documents, and select the optimum solutions and components for your IT environment.

## Engineering & Design

- Site evaluation and risk assessment
- Design and planning of complete data centres
- Optimisation of existing data centres with regard to energy, costs, processes, security, disaster recovery management and outsourcing
- External assessment of data centre and infrastructure concepts
- Efficiency analyses of energy, climate, security and IT processes

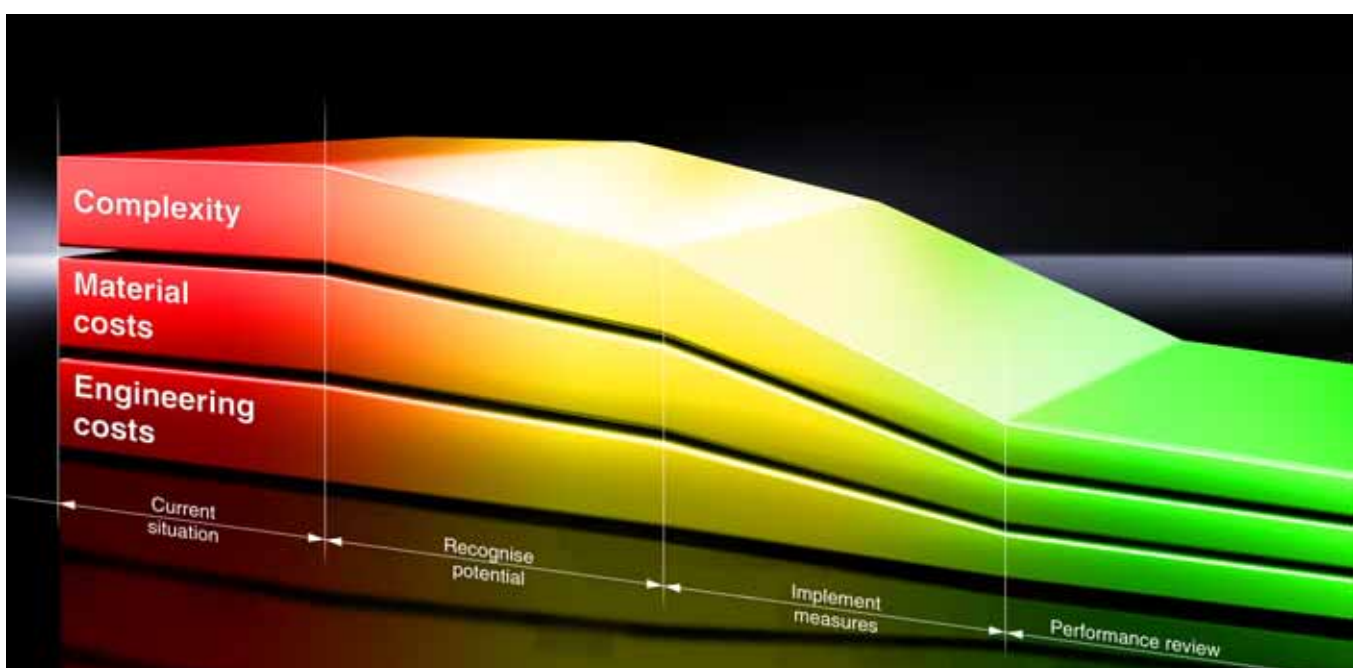

# Rittal Global Service

Rittal – The System is the perfect synthesis of highest quality products, engineering tools and customer service in one complete system package. Rittal’s service component completes our holistic solution. Rittal safeguards the long-term productivity of your manufacturing systems. An international presence alongside regional proximity, ultimate service quality and transparent costing ensures that whenever, wherever and however you need us, Rittal is at your service!

**Faster**

- Short distances and fast communication: Thanks to regional service centres and local partners
- Perfect interaction between service and engineering

**Better**

- Individual service solutions from a single partner
- High qualification standards of Rittal service technicians worldwide

**Worldwide**

- More than 250 service partners and over 1,000 service technicians

**The benefits to you:**

- Preserve the value of your systems and equipment
- Reduced downtimes via fast and reliable service
- Long-term cost management
- Service from a single partner
- Expert knowledge of your equipment and systems

Choose the form and scale of your Rittal service with standardised packages: Basic, Comfort, Advanced, Full and Customised.

## Rittal Service Packages:

	Basic	Comfort	Advanced	Full	Customised
<b>Availability</b>	Business hours	Next working day	24 hours 365 days a year	24 hours 365 days a year	24 hours 365 days a year
<b>Response Time</b>	Next working day	Next day	8 hours	4 hours	4 hours
<b>Spare Parts Availability</b>  Spare parts management guaranteeing maximum availability. * Standard ** Customer - specific spare parts	Standard	Standard	24 hours	24 hours	Individual concept
<b>Maintenance</b>  Preventative maintenance to safeguard the value of your equipment	Product Dependent	Product Dependent	Product Dependent	Product Dependent	Individual (min. 2 x per year)
<b>Extended Warranty</b>  One to three-year warranty extension for a total period of up to 5 years	Not Included	Optional	Included	Included	Included
<b>Commissioning</b>	Not Included	Not Included	Included	Included	Included

To secure your service package contact - AUS: 1800 350 665 | NZ: +61 2 9526 4900  
Email: customerservice@rittal.com.au



---

## UNIVERSITY OF SOUTHERN QUEENSLAND

Supporting approximately 2000 staff and 25,000 students over three campuses, USQ has experienced significant growth in the past few years. They chose Rittal to commission a secure efficiency room to protect critical IT assets against fire, vandalism, water, debris and theft. USQ experienced no down time during the seven day build.



---

## ELPRO / BERLIN INTERNATIONAL

Elpro is tasked with a critical mission - to safe guard all low-voltage switchgear in eight power stations at Berlin International Airport - Rittal's complete system solutions play an integral part. Elpro chose Rittal's Ri4Power to ensure quick connection without the need for machining. This technology was supported via the TS 8 platform. Project planning was made simple and efficient via Rittal's Power Engineering software.



---

## FRANKFURT AIRPORT

To protect control electronics and power distribution Fraport Airport chose to install Rittal TS 8 enclosures together with TopTherm cooling units. The growing airport meant overwhelming heat load in the terminal 2 network station. Fraport installed Rittal's LCP Extend cooling unit to reduce the temperature to around 20 degrees.



---

## MICROSOFT

The world's leading software developer, Microsoft used Rittal for energy efficient and scalable cooling via the LCP Plus system. This is supported by Rittal's high-load TS 8 server enclosures.



---

## ORION NEW ZEALAND LTD

Following the devastating Christchurch earthquakes, Orion Energy (owner and operator of the greater Christchurch electricity distribution network) sustained severe damages to their Computer Facilities. Rittal was commissioned to supply a transportable Data Centre container. The leading-edge data centre, built to stringent earthquake standards, was delivered quickly to protect Orion's sophisticated suite of network control and monitoring equipment.



---

## SIEMENS

Siemens WKC uses integrated system solutions from Rittal to streamline production processes. Siemens use Rittal RiCAD-3D to model enclosure configuration together with Rittal climate control calculation tool – Therm. Pre machined TS8 enclosures are provided to save considerable time during assembly.



---

## AUSTRALIAN STOCK EXCHANGE (ASX)

Australian Stock Exchange (ASX) chose Rittal to develop and deploy the data centre of the future. The \$36 million upgrade included 440 Rittal TS 8 data racks. The TS8 platform was selected for its flexibility, adaptability, easy installation and security provided by 4 point locking electronic reporting of rack access.



# Index

<b>A</b>					
Air baffle plate	11				
Aisle containment	61				
<b>B</b>					
Base mount	22				
Battery packs					
– for PMC 12	31				
Baying connector					
– for TS	12				
Blanking panel	12				
<b>C</b>					
Cable duct	16				
Cable entry panel					
– 482.6 mm (19")	18				
Cable finger	17				
Cable lock PSM	45				
Cable management panel					
– 2 U 37	17				
Cable manager	15				
Cable tray	19				
Cable routing bars	16				
Cable routing channel					
– 482.6 mm (19")	18				
Cable shunting ring	15				
Cage nuts M6 & screws	19				
Castors	22				
Castor kits TS-IT	22				
Chillers	62				
CMC III	65				
– Processing unit	66				
– Processing unit compact	66				
Compact light	27				
Component shelf					
– Static installation	13				
Component shelves					
– 2 U, static installation	13				
– Pull-out	13				
Connection cable					
– for PSM busbar	45				
Cover, magnetic	11				
<b>D</b>					
Drawer, 2 U, 3 U					
– 482.6 mm (19")	21				
DET - AL/EFD	90				
Door control system	71				
<b>E</b>					
Earth rails	21				
<b>F</b>					
Fan mounting plate	11				
Feet (levelling)	22				
Fire alarm & extinguisher system	90				
<b>G</b>					
Gland plate, modular for TS IT	23				
GPO power rail	38				
<b>H</b>					
Heat exchangers					
– LCP Inline CW 60	56				
– LCP rack CW 59	55				
<b>I</b>					
IT chillers	62				
IT roof-mounted cooling units	50				
IT security rooms	77				
<b>L</b>					
LCP Rack CW	55				
Levelling feet	22				
Lights	27				
– Compact light	27				
Liquid cooling package	55				
<b>M</b>					
Modular safe					
– Level A (Compact Safe)	86				
– Level B	84				
– Level E	82				
– Cooling solutions	87				
Monitor/keyboard unit, 1 U	73				
Mounting kit light					
– Magnet	27				
Mounting kit PSM	45				
<b>N</b>					
Nylon loop	20				
Nylon tape	20				
Nylon tape supports	20				
<b>O</b>					
Overvoltage protection PSM	45				
<b>P</b>					
PDUi	39				
Potential equalisation rail	21				
Power Rails	38				
Processing unit compact, CMC III	66				
Processing unit, CMC III	66				
PSM busbar	43				
PSM mounting kit	45				
PSM socket modules	44				
<b>R</b>					
Refrigerant based cooling solution	53				
RDCC	91				
RiZone	74				
Roof-mounted cooling unit IT	50				
<b>S</b>					
Security rooms	77				
Shunting ring	15				
Side panel, divided	10				
Side panels					
– Lockable, for TS	10				
Single-phase connection cable	45				
Slide rails					
– Depth-variable	14				
– Static installation	14				
<b>T</b>					
Three-phase connection cable					
– for PSM busbar	45				
Transport kit for DK-TS	22				
TS IT					
– With glazed door					
for rack climate control	6				
– With vented door					
for room climate control	8				
Tubular door frame	10				
<b>U</b>					
UPS					
– Monitoring card (SNMP card)	31				
– PMC 12	30				
– PMC 40	33				
– PMC 120	35				
– PMC 200	36				
– Bypass switches	31				
– Sub distributions	32				
<b>W</b>					
Water-based Cooling Solutions	51				
<b>V</b>					
Vertical cable duct	16				
Vertical earth rail	21				

We reserve the right to further developments and technical modifications of our products. Such modifications, along with errors and printing errata, shall not constitute grounds for compensation. We refer customers to our Terms of Sale and Delivery.



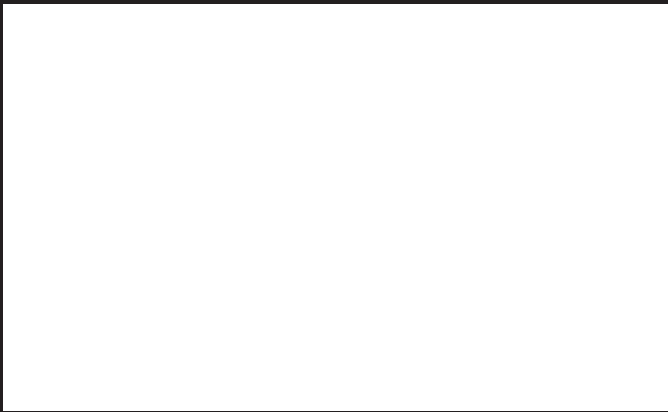

#### HEAD OFFICE AUSTRALIA

130-140 Parraweena Road,  
Miranda NSW 2228 Australia

**T** 1800 350 665

**E** [info@rittaldatacentre.com.au](mailto:info@rittaldatacentre.com.au)

**W** [rittaldatacentre.com.au](http://rittaldatacentre.com.au)  
[rittal.com.au](http://rittal.com.au)

#### HEAD OFFICE NEW ZEALAND

21 Bell Road South,  
Lower Hutt Wellington NZ

**T** 04 566 7630

**E** [sales@rittal.co.nz](mailto:sales@rittal.co.nz)

**W** [rittaldatacentre.co.nz](http://rittaldatacentre.co.nz)  
[rittal.co.nz](http://rittal.co.nz)



SYDNEY

CANBERRA

MELBOURNE

BRISBANE

ADELAIDE

PERTH

AUCKLAND

WELLINGTON

CHRISTCHURCH

RACKS

POWER

COOLING

MONITORING

SECURITY

SERVICE & SUPPORT

