

1 YEAR LIMITED WARRANTY

PERFORMANCE TOOL® extends only the following warranties, and only to original retail purchasers. These warranties give specific legal rights. Except where prohibited by local law, the law of the State of Washington governs all warranties and all exclusions and limitations of warranties and remedies. There may be other rights which vary from state to state.

PERFORMANCE TOOL® warrants the product to be free from defects in materials and workmanship under normal use and service. A defective product may be returned for a free replacement within 90 days from the date of purchase, provided that product is returned to place of purchase immediately after discovery of defect. After 90 days and up to one year from date of purchase, PERFORMANCE TOOL® will replace at no charge any parts which our examination shall disclose to be defective and under warranty. These warranties shall be valid only when a sales receipt showing the date of purchase accompanies the defective product or defective part(s) being returned. For part(s) after 90 days, please remit your request, postage prepaid to:

PERFORMANCE TOOL, P.O. Box 88259 Tukwila, WA 98138

These warranties exclude blades, bits, punches, dies, bulbs, fuses, hoses, and other consumables which must be replaced under normal use and service. These warranties shall not apply to any product or part which is used for a purpose for which it is not designed, or which has been repaired or altered in any way so as to affect adversely its performance or reliability, nor shall these warranties apply to any product or part which has been subject to misuse, neglect, accident or wear and tear incident to normal use and service.

PERFORMANCE TOOL® does not authorize any other person to make any warranty or to assume any liability in connection with its products.

Except for warranties of title and the limited express warranties set forth above, PERFORMANCE TOOL® makes no express or implied warranties of any kind with respect to its products. In particular, PERFORMANCE TOOL® makes no implied warranty of merchantability and no implied warranty of fitness for any particular purpose, except that for goods purchased primarily for personal, family or household use and not for commercial or business use, PERFORMANCE TOOL® makes an implied warranty of merchantability (and, if otherwise applicable, an implied warranty of fitness for a particular purpose), but only for the particular qualities or characteristics, and for the duration, expressly warranted above. The laws on limitation of implied warranties may differ from state to state, so the above limitations may not apply in all cases.

PERFORMANCE TOOL® shall not be liable for consequential, incidental or special damages resulting from or in any manner related to any product, or to the design, use, or any inability to use the product. The sole and exclusive remedy for a defective product or part shall be the repair, or replacement thereof as provided above. The laws on limitation of remedies or on consequential, incidental or special damages may vary from state to state, so the above limitations may not apply in all cases.

10 TON HYDRAULIC RAM SYSTEM

Item Number W1651

OWNER'S MANUAL

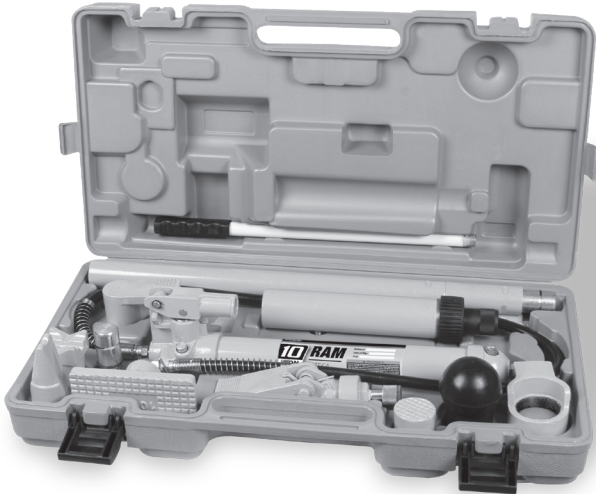

Performance Tool®

▲WARNING!

READ, UNDERSTAND AND FOLLOW ALL INSTRUCTIONS AND WARNINGS BEFORE OPERATING THIS TOOL. FAILURE TO DO SO MAY RESULT IN PERSONAL INJURY AND/OR PROPERTY DAMAGE AND WILL VOID WARRANTY.

The owner and/or operator are responsible for maintenance, maintaining all decals or warning labels and while in use, maintaining the unit in good working order. If the owner and/or operator are not fluent in English, the product warnings and instructions shall be read and discussed with the operators' native language by the purchaser/owner or his designee. Make sure that the operator comprehends its contents. Safety information shall be emphasized and understood prior to usage. The product shall be inspected per the operating instructions.

Users of this product must fully understand these instructions. Each person operating this product must also be of sound mind and body and must not be under the influence of any substance that might impair their vision, dexterity, or judgment.

Protect yourself and others by observing all safety information.

Failure to comply with instructions could result in personal injury and/or property damage! If you encounter any problems or difficulties, please contact our customer service department at:

1-800-426-1262 between 6:30 a.m. and 4:30 p.m. Pacific time.

PT

Performance Tool

SAFETY GUIDELINES / DEFINITIONS

This instruction manual is intended for your benefit. Please read and follow the safety, installation, maintenance and troubleshooting steps described within to ensure your safety and satisfaction. The contents of this instruction manual are based upon the latest product information available at the time of publication. The manufacturer reserves the right to make product changes at any time without notice.

▲WARNING: Read and understand this entire instruction manual before attempting to assemble, install, operate or maintain this product. Failure to comply with the instructions may result in serious personal injury and/or property damage!

The following signal words are used to emphasize safety warnings that must be followed when using this product:

▲DANGER Indicates an imminently hazardous situation that, if not avoided, **WILL** result in death or serious injury.

▲WARNING Indicates a potentially hazardous situation that, if not avoided, **COULD** result in death or serious injury.

▲CAUTION Indicates a potentially hazardous situation that, if not avoided, **MAY** result in minor or moderate injury.

▲NOTICE Indicates important information, which if not followed, **MAY** cause damage to equipment.

UNPACKING AND INSPECTION

After opening the carton, unpack your new product and related parts & accessories. Please inspect it carefully for any damage that may have occurred during transit. Please check it against the photograph on carton. If any parts are missing, please call customer service at 1-800-426-1262 between 6:30 a.m. and 4:30 p.m. Pacific time.

▲WARNING DO NOT operate this product if damaged during shipment, handling or misuse. Do not operate the product until the parts have been replaced or the fault rectified. Failure to do so may result in serious personal injury or property damage. All damaged parts must be repaired or replaced as needed prior to operating this product. Check to see that all nuts, bolts and fittings are secure before putting this product into service. If you have any questions, or require assistance with damaged or missing parts, please contact our factory customer service department at: 1-800-426-1262.

Please have the serial number, model number, and date of purchase available for reference when calling.

SPECIFICATIONS

Capacity: 10 Ton (20,000 lbs.), 5 Ton (10,000 lbs.) with extensions
Ram Travel: 6 in.
Extension Pole Length:..... 5 ft. Maximum
Spreader Wedge Capacity: 1/2 Ton, 3 3/4 in. Maximum Opening
Hose Length:..... 6 ft.

Specifications are subject to change without notice

IMPORTANT SAFETY INFORMATION

▲WARNING
READ, UNDERSTAND AND FOLLOW ALL INSTRUCTIONS AND WARNINGS BEFORE OPERATING THIS TOOL. FAILURE TO DO SO MAY RESULT IN PERSONAL INJURY AND/OR PROPERTY DAMAGE AND WILL VOID WARRANTY.

REPLACEMENT PARTS LIST

SPREADER WEDGE

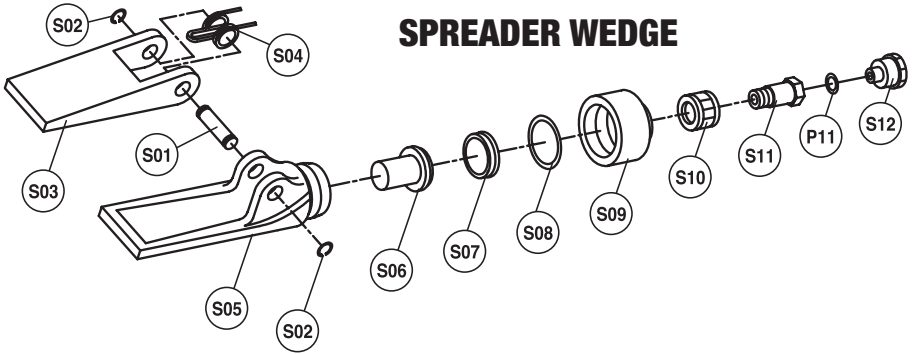

#	Description	Qty	#	Description	Qty
S01	Pin	1	S08	O-ring	1
S02	Circlip	1	S09	End Cap	1
S03	Moveable Jaw	1	S10	Coupling Ring	1
S04	Spring	1	S11	Coupling Bolt	1
S05	Fixed Jaw	1	P11	O-Ring	1
S06	Piston	1	S12	Dust Cap	1
S07	Cup Seal	1			

RAM

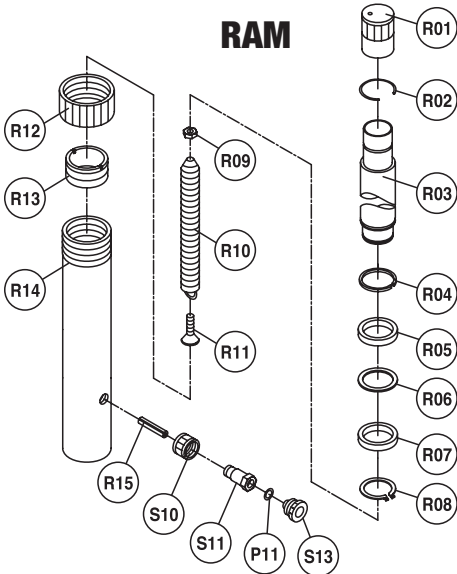

#	Description	Qty
R01	Cover	1
R02	Circlip	1
R03	Piston Rod	1
R04	Circlip	1
R05	Bushing	1
R06	Nylon Ring	1
R07	Sealing Ring	1
R08	Circlip	1
R09	Nut	1
R10	Spring	1
R11	Screw	1
R12	Protection Cup	1
R13	Ring	1
R14	Cylinder	1
R15	Screw	1
S10	Coupling Ring	1
S11	Coupling Ring	1
P11	O-Ring	1
S13	Dust Cap	1

REPLACEMENT PARTS LIST

PUMP

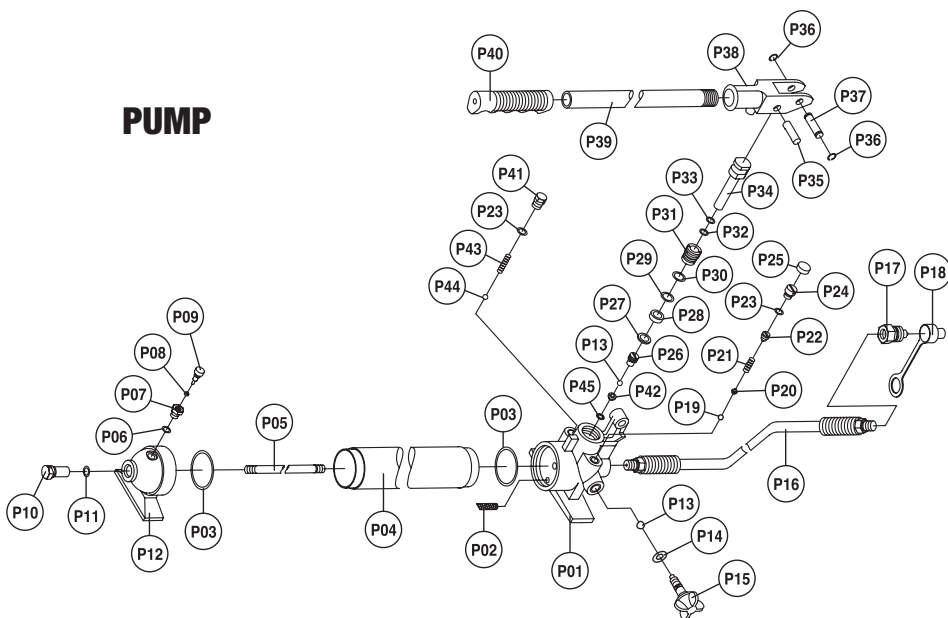

#	Description	Qty	#	Description	Qty
P01	Valve Block	1	P24	Screw	1
P02	Oil Filter	1	P25	Plastic Cup	1
P03	O-ring	1	P26	Screw	1
P04	Reservoir	1	P27	Nylon Ring	1
P05	Tie Rod	1	P28	Sealing Ring	1
P06	Nylon Ring	1	P29	O-Ring	1
P07	Fill Plug	1	P30	Nylon Ring	1
P08	Sealing Ring	1	P31	Screw	1
P09	Air Valve	1	P32	O-Ring	1
P10	Screw	1	P33	Nylon Ring	1
P11	O-ring	1	P34	Piston	1
P12	Pump Leg	1	P35	Pin	1
P13	Ball	2	P36	Circlip	2
P14	O-ring	1	P37	Pin	1
P15	Release Valve	1	P38	Handle Bracket	1
P16	Hydraulic Hose	1	P39	Handle	1
P17	Coupler	1	P40	Handle Sleeve	1
P18	Dust Proof Cover	1	P41	Screw	1
P19	Ball	1	P42	Valve Base	1
P20	Ball Cup	1	P43	Spring	1
P21	Spring	1	P44	Ball	1
P22	Safety Valve screw	1	P45	Nylon Washer	1
P23	O-ring	2			

IMPORTANT SAFETY INFORMATION

1. Study, understand, and follow all instructions before operating this device.
2. DO NOT exceed rated capacity. Overloading can cause damage to or failure of this tool.
3. Use only accessories that are identified by the manufacturer for the specific tool model. Use of an accessory not intended for use with the specific tool model, increases the risk of injury and/or property damage.
4. Wear ANSI approved safety goggles and heavy duty work gloves during use.
5. Avoid off center loads. If the Pump (1) seems unusually hard to operate, immediately stop. Adjust the Ram to eliminate or diminish an off center load. The Flange Base and Flange Head must only be used together to prevent an off center load.
6. Protect the Hose. Do not drop heavy objects on the Hose (P16). Avoid sharp kinks in the Hose. Maintain proper clearance to avoid damage to the Hose and Couplers.
7. Do not alter this product in any way.
8. Keep your work area clean and well lit. Cluttered work areas invite accidents.
9. Keep bystanders, children and visitors away while operating this product. Distractions can cause you to lose control.
10. Stay alert. Watch what you are doing and use common sense when operating this product. Do not use this product while tired or under the influence of drugs, alcohol or medication. A moment of inattention while operating may result in serious personal injury.
11. Store tools/equipment out of reach of children and other untrained persons. Tools and equipment are dangerous in the hands of untrained users.
12. Tool/equipment service must be performed only by qualified repair personnel. Service or maintenance performed by unqualified personnel could result in a risk of injury.
13. When servicing this product, use only identical replacement parts - refer to attached, product-specific parts list and diagram. Follow instructions in the Care & Maintenance section of this manual. Use of unauthorized parts or failure to follow maintenance instructions may create a risk of injury and may void any applicable warranty.
14. Maintain labels and nameplates on this product. These carry important information. If unreadable or missing, contact Performance Tool® for a replacement.
15. Industrial applications must follow OSHA requirements.
16. The warnings, precautions, and instructions discussed in this manual cannot cover all possible conditions and situations that may occur. The operator must understand that common sense and caution are factors, which cannot be built into this product, but must be supplied by the operator.

WARNING: This product and its packaging contain a chemical known to the State of California to cause cancer, birth defects, or other reproductive harm.

PACKAGING CONTENTS

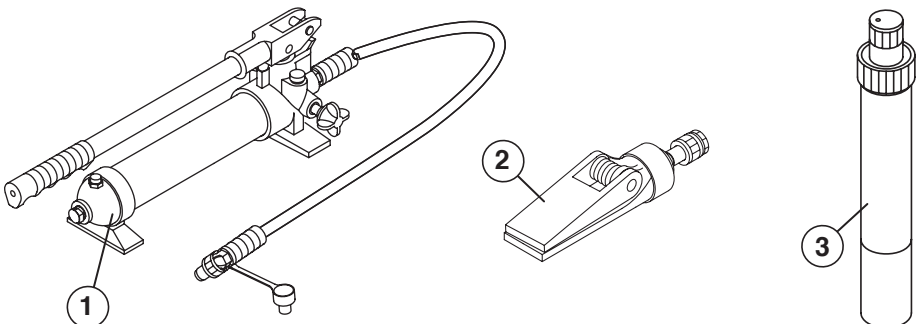

PACKAGING CONTENTS

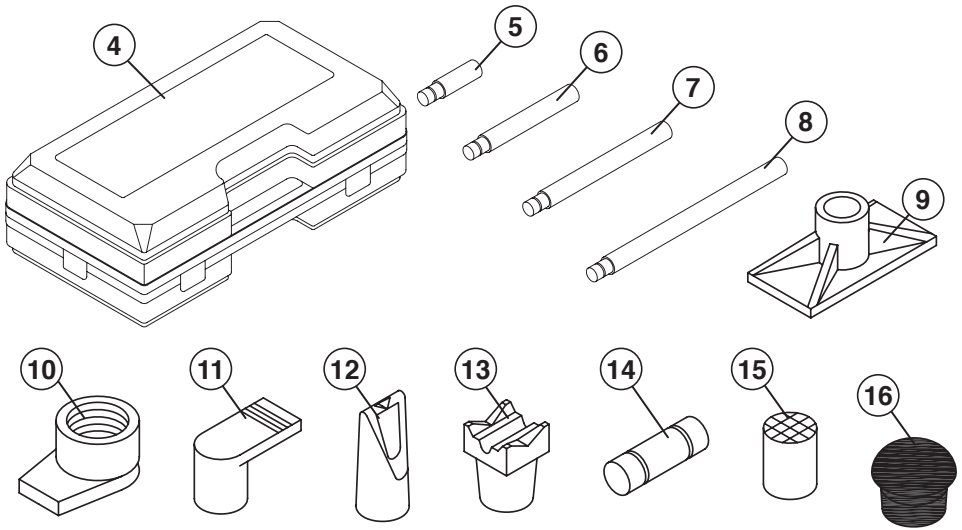

#	Description	Quantity	#	Description	Quantity
1	Pump	1	9	Flat Base	1
2	Spreader Wedge	1	10	Ram Toe	1
3	Ram	1	11	Plunger toe	1
4	Case	1	12	Wedge head	1
5	4 1/4 in. Extension	1	13	V-base	1
6	10 in. Extension	1	14	Male Connector	1
7	14 1/2 in. Extension	1	15	Cap Head	1
8	20 1/2 in. Extension	1	16	Rubber head	1

SETUP INSTRUCTIONS

Ram Attachments:

1. The Extensions (5-8) connect in different combinations to reach desired lengths.
2. The Male Connector (14) is used to connect the female end of the Ram (3) to a Base.
3. The Flat Base (9) is typically used on the stationary side to spread out the force of the Ram (3).
4. The V-Base (13) is used to offset the force of the Ram (3) when there is not a straight line between the stationary side and the damaged side, or to spread out force on curved surfaces.
5. The Cap Head (15) is typically used on the pushing end to prevent slipping.
6. The Rubber Head (16) is typically used for popping dents out of sheet metal such as doors or body panels and to minimize damage to the work surface.
7. The Wedge Head (12) is used to repair small dents and areas located in angles and tight spaces.
8. The Ram Toe (10) and Plunger Toe (11) are used together to allow spreading in areas that the Ram cannot fit into.

TROUBLESHOOTING

This Performance Tool® product was constructed with quality materials and workmanship and will give you many years of trouble free use when cared for as described in the "Care & Maintenance" section on page 7-8. However, as with any mechanical device, periodic adjustments are necessary to maintain a peak level of performance. Should this product be displaying any of the following symptoms, the simple procedures shown below will correct the problem.

▲ WARNING: Remove all equipment from service before making adjustments

Will not lift load	●	●	●
Will not hold load			●
Will not lift to full height	●	●	
Pump feels "spongy" under load	●	●	
Handle raises under load			●
Handle lowers under load			●
	Power unit may be low in fluid. With pump on level surface and in down position, remove filler plug and add clean hydraulic jack fluid to level of filler.	Power unit may be air bound. Open the release valve a minimum of 2 full turns. Pump the handle a minimum of 20 full strokes to purge air from the system.	Valve may not be closing completely. To seat valves: a.) Close release valve. b.) With pump in fully lowered position, manually raise lifting arm as high as possible. c.) Open release valve and allow pump to descend to lowered position

NOTE:

Problems listed above with more than one solution may have a combination of causes. Please be sure that all solutions listed for each problem have been checked to eliminate possibility of further trouble. Sometimes solutions may need to be repeated for best results.

CARE & MAINTENANCE

6. For best results, use only hydraulic fluid with a rating of SAE 20 for refills. Check fluid level with pump in fully down position.
7. Change the hydraulic oil at least once every three years:
 - a. Set Pump (1) flat on a level surface.
 - b. Remove the Fill Screw (A). The O-ring (B) should come off with it.
 - c. Tip the pump to allow the old hydraulic oil to drain out of the housing completely, and dispose of the old hydraulic oil in accordance with local regulations.
 - d. With the Pump upright, completely fill the housing with a high quality hydraulic oil (not included) until the oil just begins to run out of the oil fill hole. Be **VERY CAREFUL** not to allow dirt or foreign matter into the system.

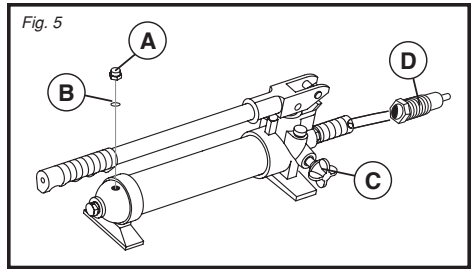

- e. Make sure the O-ring (B) is still in place around the Fill Screw (A) and thread the Fill Screw into the Pump securely. Do not use thread seal tape.
- f. Firmly close the Release Valve (C) by turning it clockwise.
- g. Clean with a clean cloth using a detergent or mild solvent.

SETUP INSTRUCTIONS

Note: The Flange Base and Flange Head must only be used together to prevent an off center load.

Note: When positioning the Ram (3) use a smaller attachment on the side that is to be bent instead of the stationary side. If the stationary side is in danger of being bent or damaged, place a block of wood or other material behind the Flat Base (9) to distribute pressure over a greater area.

Ram Setup:

Note: When positioning the Ram (3) use a smaller attachment on the side that is to be bent instead of the stationary side. If the stationary side is in danger of being bent or damaged, place a block of wood or other material behind the Flat Base (9) to distribute pressure over a greater area.

1. Clean the end of the Hose and the inlet on the Ram (3). Unscrew and save the End Plugs located on the end of the hose and Ram (3).
2. Attach the Hose to the Ram.
3. Assemble attachments as shown in figure 1 and 2.

Note: If using the Plunger Toe and Ram Toe, thread the Ram Toe onto the Ram completely and align the Plunger Toe to it.

Spreader Wedge Setup:

The Spreader Wedge (2) is used when the Ram (3) is too long to fit between the stationary side and the damaged area.

1. Clean the end of the hose and the inlet on the Spreader Wedge (2).
2. Unscrew and save the End Plugs located on the end of the hose and Spreader Wedge (2).
3. Attach the Hose to the Spreader Wedge (2), as shown in figure 3.

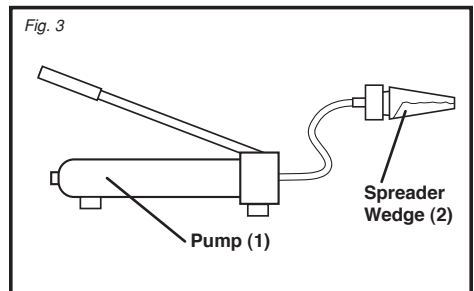
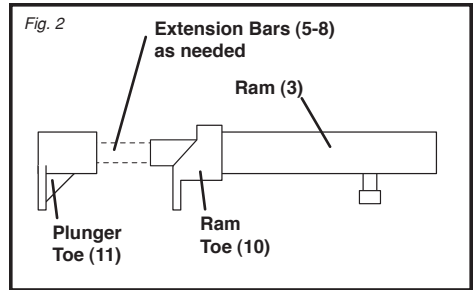
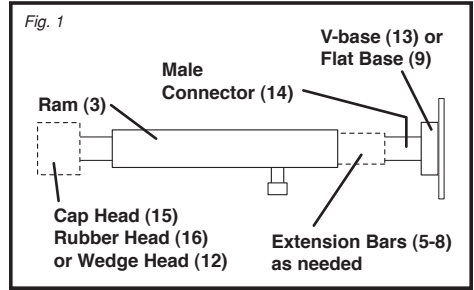

BEFORE USE

▲NOTICE During shipment or handling, air in the pump can become trapped in the hydraulic system causing the pump to malfunction.

Bleeding The Pump:

1. Set Pump (1) flat on a level surface.
2. Remove the Fill Screw (A). The O-ring (B) should come off with it.
3. The fluid level should be near the bottom of the opening. If required, add high grade hydraulic fluid.
4. Make sure the O-ring (B) is still in place around the Fill Screw (A) and thread the Fill Screw into the Pump securely. Do not use thread seal tape.
5. Firmly close the Release Valve (C) by turning it clockwise.
6. Press the tip of the Coupling (D) against a hard surface and pump the pump handle.
7. Continue pumping, until the hydraulic fluid coming out the end of the coupler tip is free of air bubbles.
8. Recheck the fluid level and add fluid if necessary.
9. Turn the Release Valve counterclockwise to release the pressure in the pump and hose.
10. Change the hydraulic fluid yearly. Remove the Fill Screw (A) and tilt the Pump (1) to drain out the old fluid. Refill the hydraulic fluid and bleed the system several times to ensure all air is out of the system.

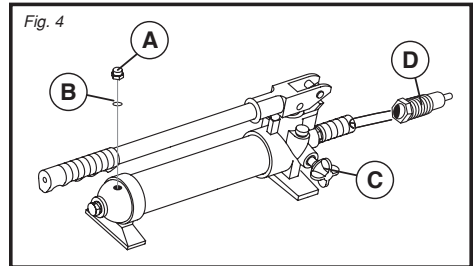

GENERAL OPERATION

▲WARNING: Read and understand all the previous sections before use of this product. Failure to comply with those sections may result in serious personal injury and/or property damage!

1. Check the Hydraulic Fluid Level, following the instructions in the Bleeding the pump section, if needed.
2. Determine which direction the frame needs to be bent.
3. Remove any obstructions that could be damaged or are in the way.

Note: When using the Pump (1) in a vertical position, keep the Hose (3) end of the Pump downward.

4A. Using Ram (2):

- a. Connect the appropriate Base (13,15,17) to the stationary side of the Ram (2), and connect the appropriate head to the pushing end of the Ram.

- Note:** When repairing larger body panel dents such as a dented door, fender or quarter-panel use the Rubber Head (11) on the pushing end.
- a. If using the Flange Base (15) or Flange Head (14): Thread the Flange Base onto the Ram completely and align the Flange Head to it. The Flange Base and Flange Head must only be used together to prevent off-center load.
 - c. Position the Ram (2) so that the Base is resting against a frame member opposite the damaged area. It must also be in line with the direction in which the damaged area needs to be pushed. The vehicle body part

GENERAL OPERATION

must be stronger than the area to be bent or it may be damaged. A block of wood or a towel may be used to protect the body part.

- d. Aim the pushing end towards the area that needs to be repaired, and slowly apply pressure with the Pump (1).

Note: To prevent damage, do not overextend the Ram.

4B. Using Spreader Wedge (10):

- a. Place the Spreader Wedge (10) so that the hinged (pushing) arm is resting against the part to be moved and the stationary arm is resting against a non-movable base.
- b. Carefully hold the Spreader Wedge in position and apply the Pump (1) pressure.

5. Once both ends have made contact, move as far away as possible and continue to slowly apply pressure to the damaged area until the desired bend has been made.

▲CAUTION Keep hands away from contact areas and tight spaces. The tool may slip and cause injury.

6. When the damaged area has been bent to the desired position, slowly turn the Release Valve (10C) counterclockwise to release the hydraulic pressure and remove the Ram (2) or Spreader Wedge (10).

7. Clean all hydraulic ports and cover them with clean End Plugs to prevent contamination and damage.

CARE & MAINTENANCE

Monthly maintenance is recommended. Lubrication is critical to the ram and pump as they support heavy loads. Any restriction due to dirt, rust, etc. can cause either slow movement or cause extremely rapid jerks, damaging the internal components. The following steps are designed to keep the pump and ram maintained and operational.

1. Before each use, inspect the general condition of the product. Check for broken, cracked, or bent parts, loose or missing parts, and any condition that may affect the proper operation of the product. Any equipment that appears damaged in anyway must be removed from service. Have the problem corrected before further use. **DO NOT** use damaged equipment.
2. Replace worn or damaged parts with Performance Tool® replacement parts. Be sure that only qualified personnel perform repairs. **DO NOT** attempt to weld, rivet or otherwise repair this device.
3. Before each use, thoroughly test the equipment for proper operation prior to its actual use. If the equipment appears not to be working properly, follow bleeding instructions on page 6.
4. When the product is not in use, ram and pump piston should be in fully down position to keep their machined surfaces free from corrosion.
5. Keep the surface of this equipment and its accessories free of hydraulic fluid and grease. Use only a mild detergent and damp cloth when cleaning. Do not use a flammable or combustible solvent to clean this tool or its accessories.