

# NIBCO®

AHEAD OF THE FLOW®



Fire Protection Valves

# Business-to-Business Solutions

Look to NIBCO for technology leadership.

The velocity with which e-business evolves demands that new products and services be continuously developed and introduced to keep our customers at the center of our business efforts. NIBCO provides an entire suite of business-to-business solutions that is changing the way we interact with customers.



[NIBCOpartner.com<sup>SM</sup>](#) is an exclusive set of secure web applications that allow quick access to customer-specific information and online order processing. This self-service approach gives you 24/7 access to your order status putting you in total control of your business.

Real time information includes:

- Online order entry
- Viewable invoices & reports
- Inventory availability
- Current price checks
- Order status
- Online library of price sheets, catalogs & submittals



**Electronic Data Interchange (EDI)** makes it possible to trade business documents at the speed of light. This technology cuts the cost of each transaction by eliminating the manual labor and paperwork involved in traditional order taking. This amounts to cost-savings, increased accuracy and better use of resources.

With EDI, you can trade:

- Purchase orders
- PO Acknowledgements
- Invoices
- Product activity data
- Advanced ship notices
- Remittance advice



**Vendor Managed Inventory (VMI)**, a sophisticated service for automated inventory management, reduces your overhead by transferring inventory management, order entry and forecasting to NIBCO. This is an on-going, interactive partnership with NIBCO.

Through automation, VMI brings results:

- Improves customer service
- Optimum inventory efficiencies
- Better forecasting
- Cuts transaction costs
- Peace of mind
- Relief from day-to-day management





# Table of Contents

Visit our website for the most current information .

	<b>Page</b>		<b>Page</b>
<b>Bronze UL/FM Valves and Trim</b> .....	<b>4-17</b>	<b>Hi Rise Valves</b> .....	<b>31-36</b>
Illustrated Index .....	4	Illustrated Index .....	31
T-104-O .....	5	F-637-31 .....	32
KT/KG-505 .....	6	F-667-0 .....	33
T-103-HC .....	7	F-697-0 .....	34
T-331-HC .....	8	F-938-31 .....	35
KT-65-UL .....	9	F-968-B .....	36
KT-211-W-UL .....	10	<b>Iron UL/FM Butterfly Valves</b> .....	<b>37-45</b>
KT-67-UL .....	11	Illustrated Index .....	37
T-301-W .....	12	WD/LD-3510-4/8 .....	38
KT-291-W3 .....	13	WD/LD-3510-C-8 .....	39
KT-403-W .....	14	GD-1765-8N .....	40
T-480 .....	15	GD-4865-8N .....	40
T-585-70 .....	16	GD-4865-C-8N .....	41
KT-580/585-70-UL .....	17	GD-6865-8N .....	42
<b>Iron UL/FM Valves</b> .....	<b>18-31</b>	GD-6865-C-8N .....	43
Illustrated Index .....	18	Butterfly Indicator Post .....	44
F-607-OTS .....	19	TS-2M Replacement Instructions .....	45
F-607-RW .....	20	TS4 Replacement Instructions .....	46
F/M-609 .....	21	<b>Flow Data</b> .....	<b>47</b>
F/M-609-RW .....	22	<b>Properties of Valve Materials</b> .....	<b>48-49</b>
FM609-RW .....	23	<b>Gate Valve Dimensions for Supv. Switch</b> .....	<b>50</b>
NIP-1AJ .....	24	<b>Grooved Pipe Specification</b> .....	<b>51</b>
NIP-3AJ .....	25	<b>Figure Number Comparisons</b> .....	<b>52</b>
KG-900-W .....	26	<b>Typical Fire Sprinkler System</b> .....	<b>53</b>
KG-900-W 350 .....	27	<b>Warranty</b> .....	<b>54</b>
KW-900-W .....	28		
F-908-W .....	29		
G-917-W .....	30		
	<b>Page</b>		

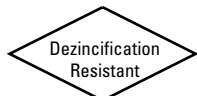

**De-alloying corrosion, known as "Dezincification," was effectively eradicated from valve products in the 1950s. Today, however, this problem has returned with the increased use of high-zinc alloys (commonly referred to as 'Yellow Brass') in forged and cast valves typically produced outside the United States.**

**Dezincification selectively removes zinc from the alloy, leaving behind a porous, copper-rich structure that has little mechanical strength. The physical attributes of an in-service valve with dezincification includes a white powdery substance or mineral stains on its exterior surface.**

**What's the cure? On all bronze valves the metal components in the waterway must not contain more than 15% zinc in their chemical makeup. As a standard NIBCO bronze fire protection valves are made to be "Dezincification Resistant," which is a seal of quality and longevity.**

# Bronze UL/FM & Trim Valves

## Illustrated Index

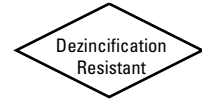

<p>UL/ULC Listed • FM Approved Bronze Gate Valve Outside screw and yoke 175 PSI WWP</p>  <p><b>T-104-0</b> Sizes ½" thru 2" Threaded ends <b>Page 5</b></p>	<p>UL Listed • FM Approved Bronze Ball Valve with weather-proof indicating gear operator 300 PSI WWP</p>  <p><b>KT-505-W-8</b> Threaded ends <b>KG-505-W-8</b> Grooved ends <b>Page 6</b></p>	<p>UL Listed • FM Approved Bronze Hose Gate Valve with cap and chain 175 PSI WWP</p>  <p><b>T-103-HC</b> Size 2½" Threaded ends <b>Page 7</b></p>	<p>UL Listed • FM Approved Bronze Angle Valve with cap and chain 300 PSI WWP</p>  <p><b>T-331-HC</b> Size 2½" Threaded ends <b>Page 8</b></p>
<p>UL Listed Bronze Globe Valve Rubber Disc 175 PSI WWP</p>  <p><b>KT-65-UL</b> Sizes ¼" thru 1" Threaded ends <b>Page 9</b></p>	<p>UL Listed Bronze Globe Valve Rubber Disc 175 PSI WWP</p>  <p><b>KT-211-W-UL</b> Sizes 1¼" thru 3" Threaded ends <b>Page 10</b></p>	<p>UL Listed Bronze Angle Valve Rubber Disc 175 PSI WWP</p>  <p><b>KT-67-UL</b> Sizes ½" thru 1" Threaded ends <b>Page 11</b></p>	<p>UL/ULC Listed Bronze Angle Valve Rubber Disc 175 PSI WWP</p>  <p><b>T-301-W</b> Sizes 1¼" thru 3" Threaded ends <b>Page 12</b></p>
<p>Bronze Side Outlet Globe Valve Rubber Disc 400 PSI WWP</p>  <p><b>KT-291-W3</b> Size ¼" Threaded ends <b>Page 13</b></p>	<p>Bronze Check Valve Horizontal swing Rubber Disc 200 PSI WWP</p>  <p><b>KT-403-W</b> Sizes ½" thru 3" Threaded ends <b>Page 14</b></p>	<p>Bronze Check Valve Spring Actuated Inline Lift Rubber Buna-N Disc 250 PSI WWP</p>  <p><b>T-480</b> Sizes ¾" thru 2" Threaded ends <b>Page 15</b></p>	<p>Bronze Ball Valve Full Port PTFE Seats 600 PSI WWP</p>  <p><b>T-585-70</b> Sizes ¼" thru 2" Threaded ends <b>Page 16</b></p>
<p>UL Listed • FM Approved Bronze Ball Valve PTFE Seats 175 PSI WWP</p>  <p><b>KT-580-70-UL</b> <b>KT-585-70-UL</b> Sizes ¼" thru 3" Threaded ends <b>Page 17</b></p>			

# 175 PSI WWP Bronze Gate Valves

Fire Protection Valve • Screw-over Bonnet •  
Outside Screw and Yoke • Solid Wedge

**175 PSI/12.1 Bar Non-Shock Cold Water  
(400 PSI Non-Shock CWP General Service)**

UL/ULC LISTED\* • FM APPROVED • APPROVED BY THE  
NEW YORK CITY B.S.A. 143-69-SA

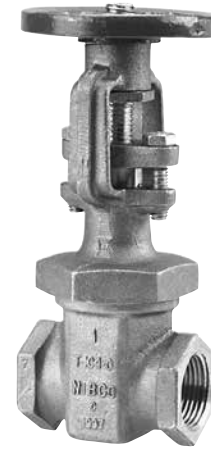
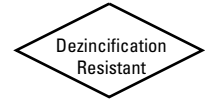

**T-104-0**  
Threaded

### MATERIAL LIST

PART	SPECIFICATION
1. Set Screw	Steel ASTM A307
2. Handwheel	Malleable Iron
3. Yoke Bushing	Brass ASTM B16
4. Gland Bolts	Steel ASTM A307 Zinc Plated
5. Packing Gland	Bronze ASTM B62
6. Packing	Non Asbestos Aramid Fibers w/Graphite
7. Bonnet	Bronze ASTM B62
8. Stem	Silicon Bronze ASTM B371 Alloy C69430
9. Stem Collar	Silicon Bronze ASTM B371 Alloy C69430
10. Wedge Pin	Bronze ASTM B140 Alloy C31400
11. Wedge	Bronze ASTM B62
12. Body	Bronze ASTM B62

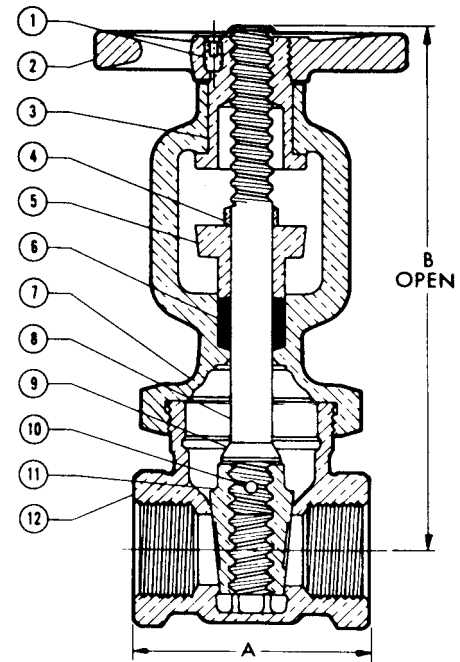

**T-104-0**  
NPT x NPT

### DIMENSIONS—WEIGHTS—QUANTITIES

Size	Dimensions				Diameter		Handwheel		Box Qty.	Master Ctn. Qty.	
	In.	mm.	In.	mm.	In.	mm.	Lbs.	Kg.			
1/2	15	2.19	59	5.88	149	3.25	88	2.28	1.04	1	20
3/4	20	2.44	62	6.44	164	3.25	88	2.83	1.29	1	20
1	25	2.88	73	7.44	189	3.25	88	3.67	1.67	1	10
1 1/4	32	3.13	79	8.69	221	4.00	100	5.83	2.65	1	10
1 1/2	40	3.38	84	9.38	238	4.00	100	6.84	3.11	1	10
2	50	3.44	87	10.59	269	3.50	89	9.74	4.44	1	6

\* Compliance with Standard for Gate Valves for Fire Protection Service, UL 262, and the Canadian Requirements.



# 300 PSI WWP Bronze Ball Valves

Fire Protection Valve • Threaded or Grooved Body Style • Full Port Design 1" - 2" • Standard Port Design 2½"

## 300 PSI/20.7 Bar Non-Shock Cold Water

CONFORMS TO MSS SP-110 • FM APPROVED FOR INDOOR AND OUTDOOR SERVICE • UL LISTED FOR INDOOR AND OUTDOOR SERVICE\* • CALIFORNIA STATE FIRE MARSHAL LISTING NO. 7770-1243:103

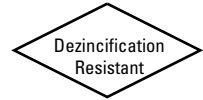

**KT-505-W-8**  
Threaded



**KG-505-W-8**  
Grooved (2" & 2½" only)

### MATERIAL LIST

PART	SPECIFICATION
1. Body	Bronze ASTM B584 Alloy C84400
2. Ball	Chrome Plated Brass ASTM B124 Alloy C37700
3. Seat Ring	Carbon-filled PTFE
4. Thrust Washer	Reinforced PTFE
5. Stem	Bronze ASTM B371 Alloy C69430
6. Stem O-Ring	Nitrile
7. Retaining Washer	Brass
8. Retaining Ring	Steel
9. Ground Wire Screw	Steel
10. 505-8 Act Assy.	Brass
11. Body End	Bronze ASTM B584 Alloy C84400
12. Mounting Screw	Steel
13. Lock Washer	Steel
14. Handle Pin	Brass
15. Hand Wheel	Steel/plastisol coated (1¼" -2½") Brass Tee Handle (1")
16. Indicator Flag	Painted Steel
17. Body Gasket	Elastomer
18. Lead Screw O-Ring	Nitrile
19. Thrust Washer	Anti-friction Polymer
20. Cover Gasket	Buna-N
21. Flag Seal O-Ring	Nitrile
22. Tamper-Proof Screw	Stainless Steel
23. Pipe Plug (-4 units)	Stainless Steel (Not shown)

Refer to page 42 for details for TS-2M Switch Kit.

\* Compliance with the applicable requirements of the Standard for Butterfly Valves for Fire Protection Service, UL 1091B.

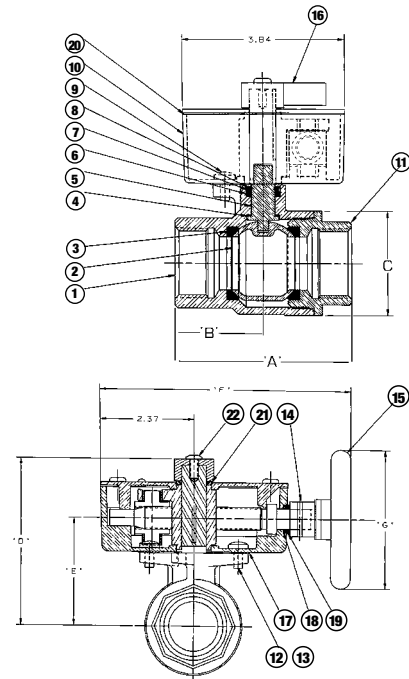

KT-505-W

## DIMENSIONS—WEIGHTS—QUANTITIES

Size	Dimensions										Cv†	Weight														
	A		B		C	D	E	F	G	G		Threated	Grooved	Box	Master											
	Threated	Grooved	Threated	Grooved												Lbs.	Kg.	Lbs.	Kg.	Qty.	Ctn. Qty.					
1	25	3.33	85	—	—	1.66	42	—	—	2.11	54	3.81	97	2.31	59	6.14	156	1.75	44	57	6.1	2.77	—	—	1	10
1¼	32	4.18	106	—	—	2.09	53	—	—	2.46	62	4.21	107	2.72	69	6.33	161	3.50	89	103	7.1	3.23	—	—	1	8
1½	40	4.70	119	—	—	2.35	60	—	—	2.95	74	4.46	113	2.97	75	6.33	161	3.50	89	143	8.1	3.68	—	—	1	4
2	50	5.15	131	6.71	170	2.57	65	3.36	85	3.69	94	4.67	119	3.18	81	6.33	161	3.50	89	245	10.7	4.86	9.7	4.40	1	4
2½	65	5.65	144	7.28	185	2.92	74	3.64	93	3.75	95	4.67	119	3.18	81	6.33	161	3.50	89	183	13.0	5.91	12.6	5.73	1	4

† Note: Cv is defined as the flow in GPM that a valve will carry with a pressure drop of 1.0 psi when the media is water at 60° F.

DO NOT USE FOR NATURAL GAS



# 175 PSI WWP Bronze Hose Gate Valves

Fire Protection Valve • Screw-in Bonnet • Non-Rising Stem • Solid Wedge

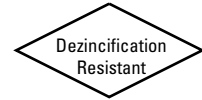

## 175 PSI/12.1 Bar Non-Shock Cold Water

CONFORMS TO MSS SP-80 • UL LISTED\*  
• FM APPROVED



### T-103-HC

Threaded  
w/Cap and Chain

### MATERIAL LIST

PART	SPECIFICATION
1. Handwheel Nut	Brass ASTM B16
2. Handwheel	Malleable Iron
3. Stem	Silicon Bronze ASTM B371 Alloy C69430
4. Packing Nut	Bronze ASTM B62
5. Packing Gland	Brass ASTM B16
6. Packing	Non Asbestos Aramid Fibers w/Graphite
7. Stuffing Box	Bronze ASTM B62
8. Bonnet	Bronze ASTM B62
9. Body	Bronze ASTM B62
10. Wedge	Bronze ASTM B62
11. Hose Cap	Bronze ASTM B62
12. Hose Cap Gasket	Rubber
13. Safety Chain	Brass

\* Compliance with the Standard for Hose Valves for Fire Protection Service, UL 668.

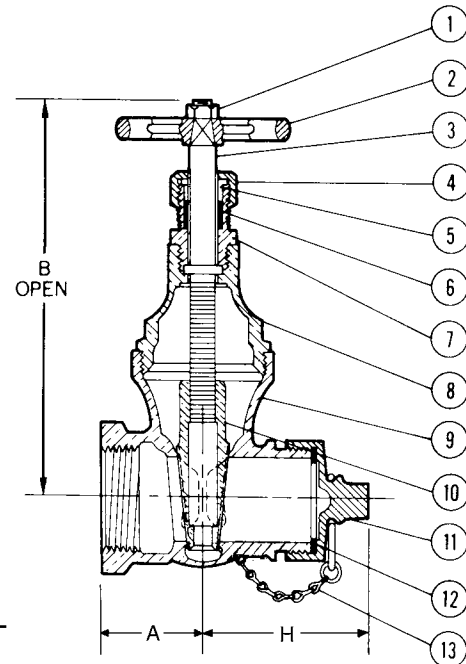

**T-103-HC**  
NPT x ANFH (NFPA)  
Hose 7.5 Threads  
Per Inch

### DIMENSIONS—WEIGHTS—QUANTITIES

Size	Dimensions						Weight		Box Qty.	Master Ctn. Qty.
	A		B		H		Lbs.	Kg.		
In. mm.	In.	mm.	In.	mm.	In.	mm.				
2½ 65	3.00	80	11.38	288	4.75	121	18.52	8.39	1	2

NOTE: National Fire Hose Threads



# 300 PSI WWP Bronze Hose Angle Valves

Fire Protection Valve • Rising Stem • Renewable Disc • Screw-in Bonnet

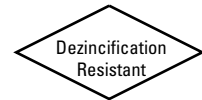

## 300 PSI/20.7 Bar Non-Shock Cold Water

- CONFORMS TO MSS SP-80 • UL LISTED\*
- FM APPROVED



**T-331-HC**  
Threaded  
w/Cap and Chain

MATERIAL LIST	
PART	SPECIFICATION
1. Handwheel Nut	Brass ASTM B16
2. Handwheel	Malleable Iron
3. Stem	Silicon Bronze ASTM B371 Alloy C69430
4. Packing Nut	Bronze ASTM B62
5. Packing Gland	Bronze ASTM B16 or ASTM B62
6. Packing	Non Asbestos Aramid Fibers w/Graphite
7. Bonnet	Bronze ASTM B62
8. Body	Bronze ASTM B62
9. Disc Holder Nut	Bronze ASTM B62
10. Drive Screw	18-8SS or Silicon Bronze ASTM B 411 Alloy C64700
11. Disc Holder	Bronze ASTM B62
12. Hose Cap	Bronze ASTM B62
13. Seat Disc	Rubber
14. Hose Cap Gasket	Rubber
15. Safety Chain	Brass
16. Seat Disc Nut	Bronze ASTM B62
17. Cotter Key	Brass

\* Compliance with the Standard for Hose Valves for Fire Protection Service, UL 668.

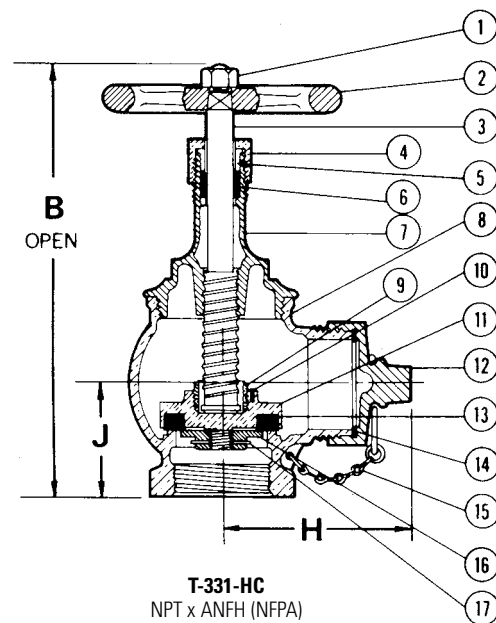

**T-331-HC**  
NPT x ANFH (NFPA)  
Hose 7.5 Threads  
Per Inch

## DIMENSIONS—WEIGHTS—QUANTITIES

Size	Dimensions						Weight		Box Qty.	Master Ctn. Qty.
	B		H		J		Lbs.	Kg.		
In. mm.	In.	mm.	In.	mm.	In.	mm.				
2½ 65	10.50	267	5.13	130	3.06	78	15.61	7.08	1	4

NOTE: National Fire Hose Threads





# 175 PSI WWP Bronze Globe Valves

Fire Protection Valve • Threaded Ends • Rubber Disc • Screw Over Bonnet

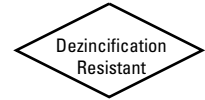

## 175 PSI/12.1 Bar Non-Shock Cold Water

UL LISTED\*



**KT-65-UL**  
Threaded

### MATERIAL LIST

PART	SPECIFICATION
1. Handwheel	Aluminum
2. Handwheel Screw	Carbon Steel Stainless Steel (1")
3. Stem	Bronze ASTM B584 Alloy C84400 or ASTM B505 Alloy C84400
4. Packing Nut	Bronze ASTM B584 Alloy C83600 or ASTM B16
5. Packing	Graphite Impregnated (Non Asbestos)
6. Bonnet	Bronze ASTM B584 Alloy C84400
7. Body	Bronze ASTM B584 Alloy C84400
8. Seat Disc	EPDM Rubber (1/4" - 3/8") Nitrile (1/2" - 1")
9. Seat Screw	Stainless Steel
10. Pack Washer	Sheet Brass

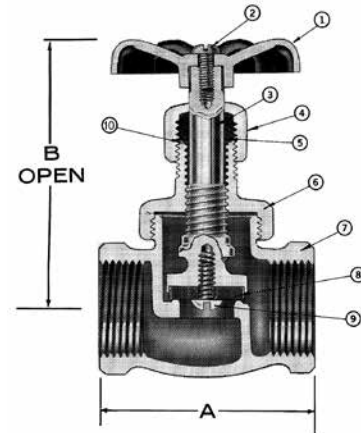

**KT-65-UL**  
NPT x NPT

### DIMENSIONS—WEIGHTS—QUANTITIES

Size	Dimensions				Weight		Box Qty.	Master Ctn. Qty.	
	In.	mm.	In.	mm.	Lbs.	Kg.			
†1/4	8	2.00	50	2.75	70	.48	.22	10	100
†3/8	10	2.00	50	2.75	70	.45	.20	10	100
1/2	15	2.28	58	3.12	79	.68	.31	10	60
3/4	20	2.28	58	3.12	79	.74	.34	10	60
1	25	3.12	79	4.50	114	1.68	.76	5	25

\* UL Listed for Trim and Drain use (Subject 258) – sizes 1/2", 3/4", 1".

Size 1/4" and 3/8" supplied as KT-65 (Not UL Listed). Subject to AHJ Approval.

† NOTE: See KT-211-W-UL for 1 1/4" -2" sizes.



# 175 PSI WWP Bronze Globe Valves

Fire Protection Valve • Screw-in Bonnet • Integral Seat • Renewable Disc

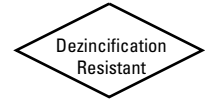

## 175 PSI/12.1 Bar Non-Shock Cold Water

CONFORMS TO MSS SP-80 • UL LISTED\*



**KT-211-W-UL**  
Threaded

### MATERIAL LIST

PART	SPECIFICATION
1. Handwheel Nut	300 Series Stainless Steel
2. Identification Plate	Aluminum
3. Handwheel	Aluminum Commercial Alloy 380
4. Stem	Silicon Bronze ASTM B371 Alloy C69430
5. Packing Gland	Bronze ASTM B62 or ASTM B584 Alloy C84400 or ASTM B282 or ASTM B16
6. Packing Nut	Bronze ASTM B62 or ASTM B584 Alloy C84400 or ASTM B16
7. Packing	Non Asbestos Aramid Fibers w/Graphite
8. Bonnet	Bronze ASTM B62
9. Disc Holder Nut	Bronze ASTM B140 Alloy C31400 or B62
10. Disc Holder	Bronze ASTM B62±/ ASTM B 9 Alloy C65100 w/SS Washer
11. Seat Disc	Nitrile (W) (1 1/4" - 2") PTFE (Y) (2 1/2" - 3")
±12. Disc Nut	Bronze ASTM B62/ASTM 89 Alloy C65100 w/SS Washer
13. Body	Bronze ASTM B62

± 2 1/2" and 3" size only.

### DIMENSIONS—WEIGHTS—QUANTITIES

Size	Dimensions				Weight		Box Qty.	Master Ctn. Qty.
	A		B		Lbs.	Kg.		
In. mm.	In.	mm.	In.	mm.				
1 1/4 32	4.31	110	6.13	156	3.55	1.61	2	10
1 1/2 40	4.69	119	7.19	183	5.50	2.49	2	10
2 50	5.38	143	7.94	202	8.25	3.75	2	6
**2 1/2 65	6.63	168	10.19	259	15.40	7.00	1	2
**3 80	7.75	197	11.19	284	22.44	10.20	1	2

\* UL Listed for Trim and Drain use (Subject 258) – sizes 1 1/4", 1 1/2", 2".

\*\* Sizes 2 1/2" and 3" supplied as T-211-Y with PTFE seat disc. Subject to AHJ Approval.

NOTE: See KT-65-UL for 1/2"-1" sizes.

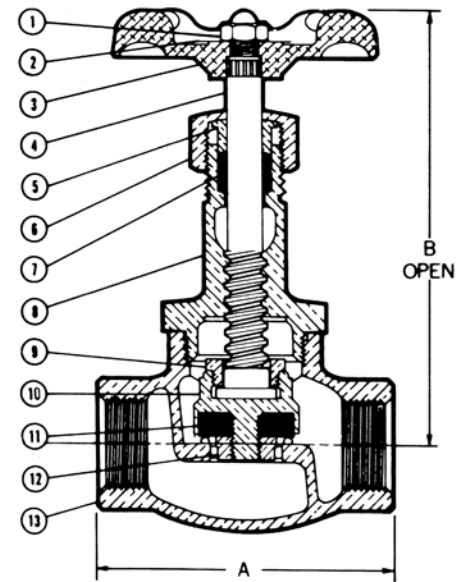

**KT-211-W-UL**  
NPT x NPT



# 175 PSI WWP Bronze Angle Valves

Fire Protection Valve • Threaded Ends • Rubber Disc • Screw Over Bonnet

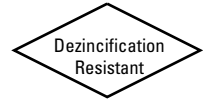

## 175 PSI/12.1 Bar Non-Shock Cold Water

UL LISTED\*



**KT-67-UL**  
Threaded

### MATERIAL LIST

PART	SPECIFICATION
1. Handwheel	Aluminum
2. Handwheel Screw	Carbon Steel (1/2" & 3/4") Stainless Steel (1")
3. Stem	Bronze ASTM B584 Alloy C84400
4. Packing Nut	Bronze ASTM B584 Alloy C83600 or ASTM B16
5. Packing	Graphite Impregnated (Non Asbestos)
6. Bonnet	Bronze ASTM B584 Alloy C84400
7. Body	Bronze ASTM B584 Alloy C84400
8. Seat Disc	Nitrile Rubber
9. Seat Screw	Stainless Steel
10. Pack Washer	Sheet Brass

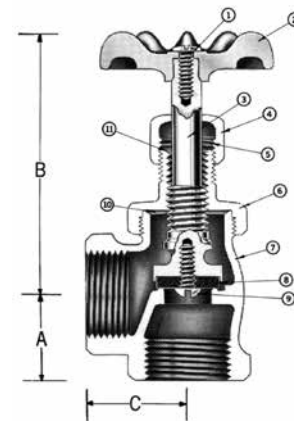

**KT-67-UL**  
NPT x NPT

### DIMENSIONS—WEIGHTS—QUANTITIES

Size	Dimensions						Weight		Box Qty.	Master Ctn. Qty.
	A		B		C		Lbs.	Kg.		
In. mm.	In.	mm.	In.	mm.	In.	mm.				
1/2 15	.94 24	3.25 83	1.06 27	.62 .28	10	60				
3/4 20	1.02 26	3.12 79	1.20 30	.70 .32	10	60				
1 25	1.80 46	4.50 114	1.62 41	1.57 .71	5	25				

\* UL Listed for Trim and Drain Use, (Subject 258).

NOTE: See T-301-W for 1 1/2" -2" sizes.



# 175 PSI WWP Bronze Angle Valves

Fire Protection Valve • Screw-in Bonnet • Integral Seat • Renewable Disc

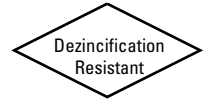

**175 PSI/12.1 Bar Non-Shock Cold Water**

CONFORMS TO MSS SP-80 • UL/ULC LISTED\*



**T-301-W**  
Threaded

## MATERIAL LIST

PART	SPECIFICATION
1. Handwheel Nut	300 Series Stainless Steel
2. Identification Plate	Aluminum
3. Handwheel	Aluminum Commercial Alloy C38000
4. Stem	Silicon Bronze ASTM B371 Alloy C69430
5. Packing Gland	Bronze ASTM B62/ ASTM B16†/ ASTM B584 Alloy C84400
6. Packing Nut	Bronze ASTM B62/ ASTM B584 Alloy C84400/ASTM B16
7. Packing	Non Asbestos Aramid Fibers w/Graphite
8. Bonnet	Bronze ASTM B62 Alloy C83600
9. Disc Holder Nut	Bronze ASTM B62 Alloy C83600
10. Disc Holder	Bronze ASTM B62 Alloy C83600
11. Seat Disc	Nitrile (W) (1 1/4" - 2") PTFE (Y) (2 1/2" - 3")
12. Seat Disc Nut	Bronze ASTM B62†/ ASTM B96 Alloy C65100 w/SS Washer
13. Body	Bronze ASTM B62/B584 Alloy C83600

‡ 2 1/2" and 3" size only.  
† Not on 2"

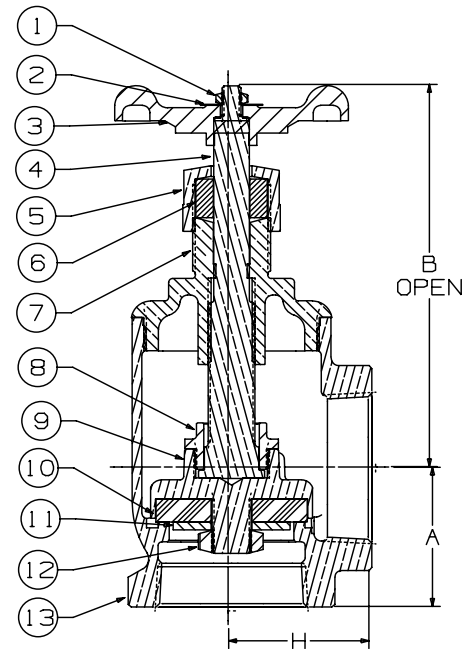

**T-301-W**  
NPT x NPT

## DIMENSIONS—WEIGHTS—QUANTITIES

Size	Dimensions						Weight		Box Qty.	Master Ctn. Qty.
	A		B		H		Lbs.	Kg.		
In. mm.	In.	mm.	In.	mm.	In.	mm.	In.	mm.	Lbs.	Kg.
1 1/4 32	2.19	56	6.13	156	2.19	56	3.71	1.69	1	10
1 1/2 40	2.38	60	7.19	183	2.38	60	5.54	2.52	1	10
2 50	2.25	57	7.25	184	2.25	57	6.72	3.05	1	10
**2 1/2 65	3.19	81	10.56	268	3.19	81	16.13	7.33	1	2
**3 80	3.88	86	11.13	283	3.88	86	21.72	9.87	1	2

\* UL/ULC Listed for sizes for trim and drain use (Subject 258) - Sizes 1 1/4", 1 1/2", 2".

\*\* Sizes 2 1/2" and 3" supplied as T-311-Y with PTFE seat disc. Subject to AHJ Approval.

NOTE: See KT-67-UL for 1/2"-1" sizes.



# 400 PSI WWP Bronze Side Outlet Globe Valves

Fire Protection Valve • 3-Way Valve • Screw-in Bonnet • Integral Seat • Renewable Disc

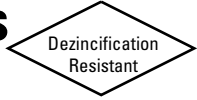

**400 PSI/27.6 Bar Non-Shock Cold Water**



**KT-291-W3**  
Threaded

## MATERIAL LIST

PART	SPECIFICATION
1. Handwheel Screw	Zinc Plated Steel
2. Handwheel	Aluminum ASTM B85 Alloy C38000
3. Stem	ASTM B133 Alloy C10200
4. Packing Nut	ASTM B16 Alloy C36000
5. Packing	Non Asbestos Aramid Fibers w/Graphite
6. Bonnet	Bronze ASTM B584 Alloy C84400
7. Disc	Nitrile
8. Disc Screw	Stainless Steel ASTM A276 Alloy S43000
9. Body	Bronze ASTM B584 Alloy C84400

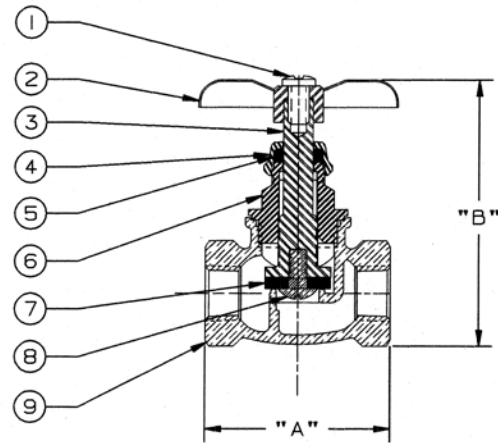

**KT-291-W3**  
NPT x NPT x NPT

## DIMENSIONS—WEIGHTS—QUANTITIES

Size	Dimensions						Weight		Box Qty.	Master Ctn. Qty.	
	A		B		C		Lbs.	Kg.			
In.	mm.	In.	mm.	In.	mm.	In.	mm.				
1/4	8	1.75	44	2.25	57	.94	24	.41	.19	10	100

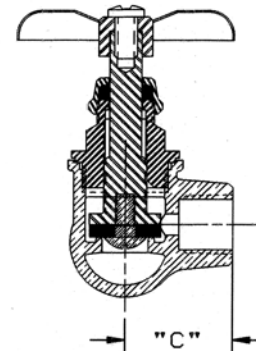

# 200 PSI WWP Bronze Check Valves

Fire Protection Valve • Horizontal Swing • Rubber Disc

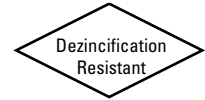

## 200 PSI/13.8 Bar Non-Shock Cold Water

CONFORMS TO MSS SP-80



**KT-403-W**  
Threaded

### MATERIAL LIST

PART	SPECIFICATION
1. Bonnet	Bronze ASTM B62 or B584 Alloy C84400
2. Body	Bronze ASTM B62 or B584 Alloy C84400
3. Hinge Pin	Bronze ASTM B140 Alloy C31400 or B134 Alloy C23000
4. Disc Hanger	Bronze ASTM B62
5. Hanger Nut	Bronze ASTM B97 Alloy C65500 or Brass ASTM B16
6. Disc Holder	Bronze ASTM B62
7. Seat Disc	Nitrile (W) PTFE (Y)†
8. Seat Disc Nut	Brass ASTM B16 or B97 Alloy C65500
9. Hinge Pin Plug	Bronze ASTM B140 Alloy C32000 (Not Shown)
*10. Seat Disc Washer	Stainless Steel

\* Sizes ¾", 1", 1¼" and 1½" only.

† 2½" and 3" size only.

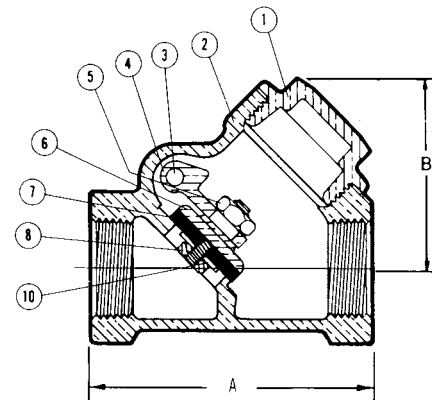

**KT-403-W**  
NPT x NPT

### DIMENSIONS—WEIGHTS—QUANTITIES

Size	Dimensions				Weight		Box Qty.	Master Ctn. Qty.
	A		B		Lbs.	Kg.		
In. mm.	In.	mm.	In.	mm.				
½ 15	2.44	62	1.69	43	.58	.26	10	50
¾ 20	2.94	75	1.88	48	.92	.42	10	50
1 25	3.56	90	2.31	59	1.55	.70	5	30
1¼ 32	4.19	106	2.69	68	2.32	1.05	5	20
1½ 40	4.50	114	2.94	75	3.00	1.36	2	10
2 50	5.25	133	3.81	97	4.87	2.21	2	10
2½ 65	8.00	203	5.06	129	11.48	5.22	1	5
3 80	9.25	235	6.25	159	17.53	7.97	1	4

Sizes 2½" and 3" supplied as T-433-Y with PTFE seat disc.

NIBCO check valves may be installed in both horizontal and vertical lines with upward flow or in any intermediate position.

**WARNING** - Valve must be installed downstream of receiver tank if used in line with reciprocating air compressor.

# 250 PSI WWP Bronze Ring Check® Valves

Fire Protection Valve • Inline Lift Type • Rubber Discs • Spring Actuated

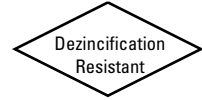

**250 PSI/17.2 Bar Non-Shock Cold Working Pressure** ♦



**T-480**  
Threaded

## MATERIAL LIST

PART	SPECIFICATION
1. Body	Bronze ASTM B584 Alloy C84400
2. Stem	Stainless Steel ASTM A582 Alloy C30300
3. Spring	316 Stainless Steel
4. Disc Holder	Stainless Steel Type 301
5. Disc	Water, Oil or Gas (Buna-N) Steam (PTFE) (Y)
6. Seat Screw	Stainless Steel ASTM A276 Alloy S43000
7. Body End	Bronze ASTM B584 Alloy C84400

## DIMENSIONS—WEIGHTS—QUANTITIES

Size	Dimensions								T-480	Master	
	A		B		C						
In.	mm.	In.	mm.	In.	mm.	In.	mm.	In.	mm.	Ctn.	Qty.
3/8	10	2.00	51	1.38	35	1.44	37	0.41	0.19	100	
1/2	15	2.06	52	1.38	35	1.19	30	0.36	0.16	100	
3/4	20	2.25	57	1.63	41	1.31	33	0.48	0.22	100	
1	25	2.63	67	2.00	51	1.50	38	0.77	0.35	50	
1 1/4	32	2.94	75	2.38	60	1.69	43	1.14	0.51	30	
1 1/2	40	3.31	84	2.75	70	2.00	51	1.63	0.74	30	
2	50	3.69	94	3.38	86	2.31	59	2.27	1.03	10	

Ordering: The T-480 has standard Buna-N Discs.

Also available with PTFE (Y) Discs; specify T-480-Y.

3/8" thru 2" require 1/2 pound pressure to open.

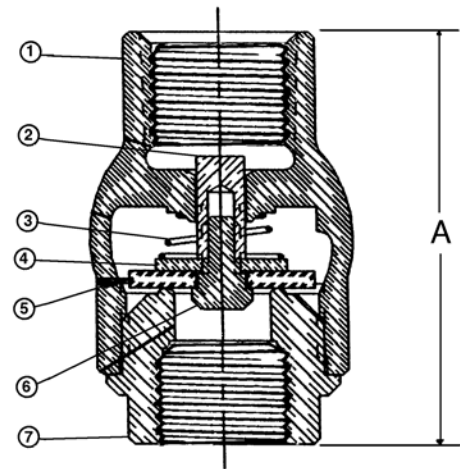

**T-480**  
NPT x NPT

NIBCO check valves may be installed in both horizontal and vertical lines with upward flow or in any intermediate position.

**WARNING** - Valve must be installed downstream of receiver tank if used in line with reciprocating air compressor.

**Do Not Use** as a Footvalve.

**Warning** - Do Not Use For Reciprocating Air Compressor Service.

# 600 PSI WWP Bronze Ball Valves

Fire Protection Valve • Two-Piece Body • Chrome Plated Ball •  
Blowout-Proof Stem • Reinforced PTFE Seats • Full Port

**600 PSI/41.4 Bar Non-Shock Cold Water**

CONFORMS TO MSS SP-110

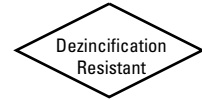

**T-585-70**  
Threaded

## MATERIAL LIST

PART	SPECIFICATION
1. Handle Nut	Zinc Plated Steel
2. Handle	Zinc Plated Steel Clear Chromate Plastisol Coated
3. Threaded Pack Gland	Brass ASTM B16 Alloy C36000
4. Packing	PTFE
5. Stem	Silicon Bronze ASTM B371 Alloy C69430 or ASTM B99 Alloy C65100
6. Thrust Washer	Reinforced PTFE
7. Ball	Brass ASTM B124 Alloy C37700 or ASTM B16 Alloy C36000 EACH with Hard Chrome Plate
8. Seat Ring (2)	Reinforced PTFE
9. Body	Cast Red Bronze ASTM B584 Alloy C84400
10. Body End Piece	Cast Red Bronze ASTM B584 Alloy C84400

1/4" and 3/8" size only has A304 stainless steel grounding washer.

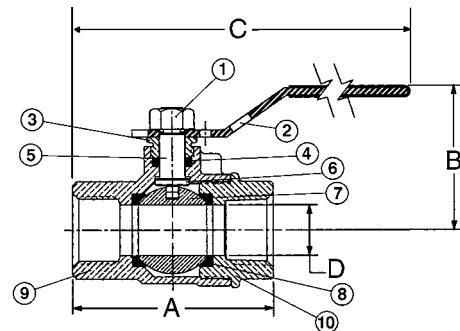

**T-585-70**  
NPT x NPT

## DIMENSIONS—WEIGHTS—QUANTITIES

Size	Dimensions								Weight	Box Qty.	Master Ctn. Qty.	
	A		B		C		D Port					
In. mm.	In.	mm.	In.	mm.	In.	mm.	In.	mm.	Lbs.	Kg.		
1/4 8	2.00	51	1.75	44	5.00	127	.38	10	.45	.20	10	100
3/8 10	2.00	51	1.75	44	5.00	127	.38	10	.45	.20	10	100
1/2 15	2.44	62	1.88	48	5.19	132	.50	13	.64	.29	10	100
3/4 20	2.94	75	2.25	57	6.25	159	.75	19	1.33	.60	5	50
1 25	3.34	85	2.38	60	6.44	164	1.00	25	1.79	.81	5	20
1 1/4 32	4.19	106	3.00	76	6.75	171	1.25	32	2.17	.99	5	20
1 1/2 40	4.72	120	3.16	80	9.06	230	1.25	32	3.27	1.49	5	10
2 50	5.16	131	3.50	89	9.25	235	2.00	51	5.09	2.31	2	8



# 300 PSI WWP Bronze Ball Valves

Fire Protection Valve • Two-Piece Body • Chrome Plated Ball •  
Blowout-Proof Stem • Reinforced PTFE Seats

**300 PSI/20.7 Bar Non-Shock Cold Water**

CONFORMS TO MSS SP-110 • UL LISTED†  
• FM APPROVED†

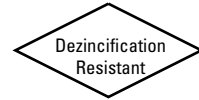

**KT-585-70-UL**

1/4" - 1" Full Port  
Threaded

**KT-580-70-UL**

1/4" - 2" Standard Port  
Threaded

## MATERIAL LIST

PART	SPECIFICATION
1. Handle Nut	Zinc Plated Steel
2. Handle	Zinc Plated Steel Clear Chromate with Platisol Grip
3. Threaded Pack Gland	Brass ASTM B16
4. Packing	PTFE
5. Stem	Silicon Bronze ASTM B371 Alloy C69430 or ASTM B99 Alloy C65100
6. Thrust Washer	Reinforced PTFE
7. Ball	Brass ASTM B124 Alloy C37700 or ASTM B16 Alloy C36000 with Hard Chrome Plate
8. Seat Ring (2)	Reinforced PTFE
9. Body	Cast Red Bronze ASTM B584 Alloy C84400
10. Body End Piece	Cast Red Bronze ASTM B584 Alloy C84400

1/4" and 3/8" size only has A304 stainless steel grounding washer.

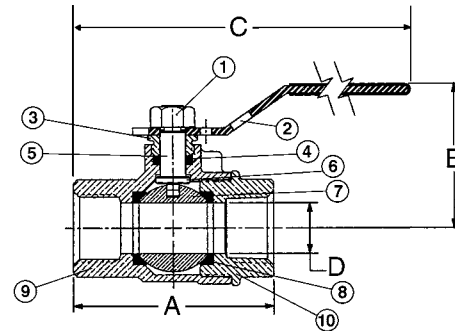

**KT-585-70-UL**

Full Port  
NPT x NPT

**KT-580-70-UL**

Standard Port  
NPT x NPT

## DIMENSIONS—WEIGHTS—QUANTITIES

Size	KT-585-70-UL Dimensions										Box Qty.	Master Ctn. Qty.	
	In.	mm.	A In.	A mm.	B In.	B mm.	C In.	C mm.	D Port In.	D Port mm.			Weight Lbs.
1/4	8	2.00	51	1.75	44	5.00	127	.38	10	.45	.20	10	100
3/8	10	2.00	51	1.75	44	5.00	127	.38	10	.45	.20	10	100
1/2	15	2.44	62	1.88	48	5.19	132	.50	13	.64	.29	10	100
3/4	20	2.94	75	2.25	57	6.25	159	.75	19	1.33	.60	5	50
1	25	3.34	85	2.38	59	6.44	164	1.00	25	1.79	.81	5	20

Size	KT-580-70-UL Dimensions										Box Qty.	Master Ctn. Qty.	
	In.	mm.	A In.	A mm.	B In.	B mm.	C In.	C mm.	D Port In.	D Port mm.			Weight Lbs.
1 1/4	32	3.94	100	2.63	67	6.75	171	1.00	25	2.17	.99	5	20
1 1/2	40	4.31	110	3.00	76	8.91	228	1.25	32	3.27	1.49	5	20
2	50	4.63	117	3.25	83	9.06	230	1.50	38	5.09	2.31	5	10
*2 1/2	65	5.84	148	3.53	90	9.66	245	2.00	51	8.25	3.79	2	6
*3	80	7.09	202	4.41	112	11.53	293	2.50	64	15.65	7.11	1	4











† UL Listed, FM Approved for trim and drain use (UL Subject 258) – 585-70-UL 1/4" thru 1" – 580-70-UL 1 1/4" thru 2".

\*2 1/2"-3" supplied as T-580-70-UL subject to AHJ approval.

DO NOT USE FOR NATURAL GAS



# UL/FM Iron Valve Illustrated Index

<p>UL/ULC Listed • FM Approved Iron Body Gate Valve Outside screw and yoke Rising stem, solid wedge 175 PSI WWP</p>  <p><b>F-607-OTS</b> Sizes 2½" thru 12" Flanged ends <b>Page 19</b></p>	<p>UL/ULC Listed • FM Approved DI Body Gate Valve Rising stem, solid resilient wedge Outside screw and yoke 250 PSI WWP</p>  <p><b>F-607-RW</b> Sizes 2½" thru 12" Flanged ends <b>Page 20</b></p>	<p>UL/ULC Listed • FM Approved Iron Body Gate Valve Indicator post pattern non-rising stem 175 PSI WWP</p>  <p><b>M-609</b> (Mechanical) <b>F-609</b> (Flanged) Sizes 4" thru 12" <b>Page 21</b></p>	<p>UL/ULC Listed • FM Approved DI Body Gate Valve (Resilient Wedge) Indicator post pattern Non-rising stem 250 PSI WWP</p>  <p><b>M-609-RW</b> (Mechanical) <b>F-609-RW</b> (Flanged) Sizes 4" thru 12" <b>Page 22</b></p>
<p>UL/ULC Listed • FM Approved DI Body Gate Valve Non-rising stem, resilient wedge 250 PSI WWP</p>  <p><b>FM609-RW</b> Sizes 4" thru 12" Flanged x Mechanical <b>Page 23</b></p>	<p>UL/ULC Listed • FM Approved Gate Valve Indicator Post</p>  <p><b>NIP-1AJ</b> Upright Indicator Post <b>Page 24 - 25</b></p>	<p>UL/ULC Listed • FM Approved Gate Valve Indicator Post</p>  <p><b>NIP-3AJ</b> Wall Indicator Post (pictured) <b>Page 26</b></p>	<p>UL/ULC Listed • FM Approved Iron Body Silent Check Valve Twin Disc, Spring Actuated Nitrile Rubber Seat 250 PSI WWP</p>  <p><b>KG-900-W</b> Sizes 2½" thru 12" Grooved <b>Page 27</b></p>
<p>UL/ULC Listed Iron Body Silent Check Valve Twin Disc, Spring Actuated Nitrile Rubber Seat 350 PSI WWP</p>  <p><b>KG-900-W 350</b> Sizes 2½", 3", 4", 6", 8", 10" Grooved <b>Page 28</b></p>	<p>UL/ULC Listed • FM Approved Iron Body Check Valve Double-Door Style, Spring Actuated Nitrile Rubber Seat 250 PSI WWP</p>  <p><b>KW-900-W</b> Sizes 2½" thru 16" Wafer Style <b>Page 29</b></p>	<p>UL/ULC Listed • FM Approved Iron Body Swing Check Valve Rubber Disc 175 PSI WWP</p>  <p><b>F-908-W</b> Sizes 2½" thru 12" Flanged ends <b>Page 30</b></p>	<p>UL/ULC Listed • FM Approved Iron Body Swing Check Valve 250 PSI WWP</p>  <p><b>G-917-W</b> Sizes 2½" thru 6" Grooved ends <b>Page 31</b></p>

# 175 PSI WWP Iron Body Gate Valves

Fire Protection Valve • Bolted Bonnet • Outside Screw and Yoke • Solid Wedge •  
Pre-Grooved Stem for Supervisory Switch Mounting

## 175 PSI/12.1 Bar Non-Shock Cold Water

CONFORMS TO MSS SP-70 • UL/ULC LISTED\* •  
FM APPROVED • APPROVED BY THE NEW YORK CITY  
B.S.A. 143-69-SA

### MATERIAL LIST

PART	SPECIFICATION
1. Stem	Brass ASTM B16 Alloy C36000
2. Handwheel Nut	Cast Bronze B584 Alloy C84400
4. Yoke Bushing	Cast Bronze B584 Alloy C84400
5. Handwheel	Cast Iron ASTM A126 Class B
6. Bonnet Cap Nut	Steel ASTM A307
7. Bonnet Cap	Ductile Iron ASTM A536
8. Bonnet	Cast Iron ASTM A126 Class B
9. Bonnet Cap Bolt	Steel ASTM A307
10. Gland Follower Nut	Brass ASTM B36
11. Gland Follower	Ductile Iron ASTM A536
12. Packing Gland	Zinc Plated Powdered Iron ASTM B310 or Cast Brass ASTM Alloy C36000
13. Packing	Non Asbestos
14. Gland Follower Bolt	Steel ASTM A307
15. Backseat Bushing	Cast Bronze B584 Alloy C84400
16. Body Nut	Steel ASTM A563
17. Body Bolt	Steel ASTM A307
18. Wedge Pin	Silicon Bronze B140 Alloy C31600
19. Body	Cast Iron ASTM A126 Class B
20. Seat Ring	Cast Bronze B584 Alloy C84400
21. Wedge Face Rings	Cast Bronze B584 Alloy C84400
22. Wedge	Cast Bronze B584 Alloy C84400
23. Body Gasket	Non Asbestos
24. Stem Collar	Brass ASTM B16 Alloy C36000

<sup>1</sup> Sizes up to 8" inclusive made with yoke integral with bonnet.  
10" and 12" sizes made with separate yoke bolted to bonnet.

<sup>2</sup> Sizes 2½" thru 6" are all bronze wedges.  
Sizes 8" thru 12" made with cast iron wedge with bronze wedge face rings

TS: pre-grooved stem for supervisory switch mounting.

NOTE: Flanged valve is consistent with ANSI B16.1 Class 125.

\* Compliance with the Standard for Gate Valves for Fire Protection Service, UL 262, and the Canadian Requirements.

### DIMENSIONS—WEIGHTS—QUANTITIES

Size	Dimensions										Weight		
	A		B		C		D		E		Lbs.	Kg.	
In. mm.	In.	mm.	In.	mm.	In.	mm.	In.	mm.	In.	mm.			
2½	65	7.50	191	16.88	429	8.00	203	7.00	178	.69	17	55	25
3	80	8.00	203	19.75	502	8.00	203	7.50	191	.75	19	66	30
4	100	9.00	229	24.00	610	10.00	254	9.00	229	.94	24	107	49
5	125	10.00	254	27.50	699	10.00	254	10.00	254	.94	24	145	66
6	150	10.50	267	31.50	800	12.00	305	11.00	279	1.00	25	179	81
8	200	11.50	292	40.75	1035	14.00	356	13.50	343	1.13	29	308	140
10	250	13.00	330	48.50	1232	16.00	406	16.00	406	1.19	30	481	219
12	300	14.00	356	57.00	1448	18.00	457	19.00	483	1.25	32	706	321



**F-607-OTS**  
Flanged

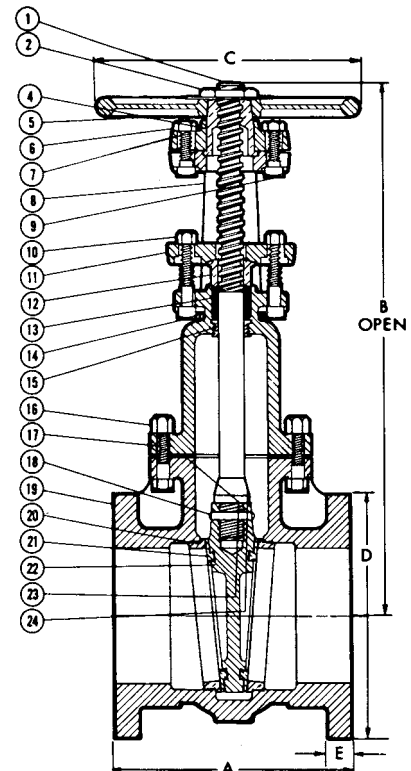

**F-607-OTS**  
Flg x Flg



**FREEZING WEATHER PRECAUTION:** Subsequent to testing a piping system, gate valve should be in an open position to allow complete drainage.

# 300 PSI CWP Iron Body Gate Valves

Fire Protection Valve • Outside Screw and Yoke • **Resilient Wedge** • Epoxy Coated Interior/Exterior • Pre-Grooved Stem for Supervisory Switch • Drilled, Tapped and Plugged at Boss Location A\*\*

## 300 PSI/20.6 Bar Non-Shock Cold Working Pressure

UL/ULC LISTED† • FM APPROVED • CERTIFIED LEAD-FREE\* BY IAPMO R&T TO NSF/ANSI 372



NSF/ANSI 372

LOW-LEAD



**F-607-RWS**  
Flanged

### MATERIAL LIST

PART	SPECIFICATION
1 Valve Body	Ductile Iron ASTM A536
2 Resilient Wedge	Ductile Iron ASTM A536/EPDM ASTM D2000
3 Wedge Nut	ASTM B584 UNS C83600
4 Dowel Pin	ASTM A276 SS304
5 Stem Back Seat O-Ring	EPDM ASTM D2000
6 Bonnet Gasket	EPDM ASTM D2000
7 Bonnet	Ductile Iron ASTM A536
8 Stem Packing	EPDM ASTM D2000
9 Threaded Rod	ASTM A276 SS304
10 Gland Bushing	ASTM B584 UNS C83600
11 Gland	Ductile Iron ASTM A536
12 Gland Nut	ASTM B148 C95200 Aluminum Bronze
13 Yoke	Ductile Iron ASTM A536
14 Yoke Bushing	ASTM B150 C61400
15 Flat Point Set Screw	ASTM F912M
16 Yoke Bushing Retainer	Cast Iron ASTM A126 Class B
17 Handwheel	Ductile Iron ASTM A536
18 Handwheel Nut	Carbon Steel Zinc Plated
19 Stem	Stainless Steel 304
20 Bonnet Screw	Corrosion-resistant Steel
21 NPT Pipe Plug	Steel ASME B16.14
22 UL/FM Label (not shown)	Aluminium
23 Yoke Nut	ASTM B148 C95200 Aluminum Bronze
24 Drive Screw Label (not shown)	Stainless Steel 304

Coating — Electrostatically applied fusion-bonded epoxy 8-20 mil. inside and outside. Meets or exceeds AWWA C550.

\*\*Drilled, tapped and plugged at Position A with 1/2" valve sizes 2 1/2"-4", 3/4" on 6"-8", 1" on 10"-12".

† Compliance with the Standard for Gate Valves for Fire Protection Service, UL 262, and the Canadian Requirements, ULC/ORD-C262.

NOTE: Flanged valve is consistent with ANSI B16.1 Class 125.

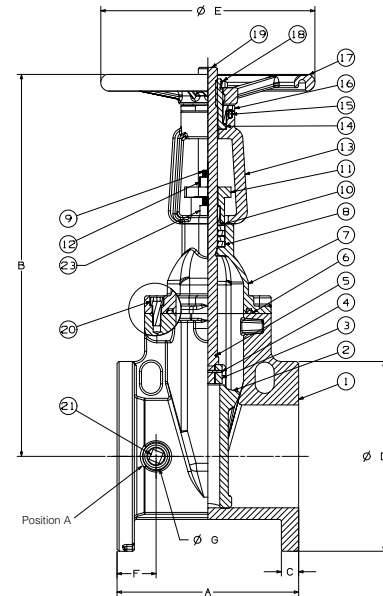

**F-607-RWS**  
Flg x Flg

### DIMENSIONS—WEIGHTS—QUANTITIES

Size	Dimensions														Bolt Circle	Flange Holes	Turns To Open	Weight					
	A		B Open		B Closed		C		D		E		F					G		Lbs.	Kg.		
In. mm.	In. mm.	In. mm.	In. mm.	In. mm.	In. mm.	In. mm.	In. mm.	In. mm.	In. mm.	In. mm.	In. mm.	In. mm.	In. mm.	In. mm.	In. mm.	In. mm.							
2 1/2	65	7.5	190	17.8	453	14.9	378	0.69	17.5	7.0	178	7.9	200	1.50	38	1.42	36	5.50	140	4	6.3	39	18
3	80	8.0	203	19.7	500	15.9	405	0.75	19.0	7.5	191	7.9	200	1.73	44	1.42	36	6.00	152	4	10.0	44	20
4	100	9.0	229	21.0	534	16.6	422	0.94	24.0	9.0	229	10.2	260	2.13	54	1.42	36	7.50	191	8	10.0	72	33
6	150	10.5	267	29.3	744	22.9	581	1.00	25.4	11.0	279	12.4	315	2.24	57	1.54	39	9.50	241	8	15.0	117	53
8	200	11.5	292	37.0	939	28.5	724	1.13	28.6	13.5	343	14.8	375	2.48	63	1.54	39	11.75	298	8	16.7	198	90
10	250	13.0	330	44.8	1139	34.5	877	1.19	30.2	16.0	406	16.4	416	3.15	80	1.82	46	14.25	362	12	20.8	374	170
12	300	14.0	356	52.2	1326	39.9	1014	1.25	31.8	19.0	483	17.5	445	2.91	74	1.82	46	17.00	432	12	25.0	493	224
14*	350	15.0	375	62.2	1580	50.0	1270	1.38	35.0	21.0	533	19.7	500	2.95	75	3.20	81	18.75	476	12	43.8	620	284
16*	400	16.0	400	65.9	1674	50.4	1280	1.44	37.0	23.5	597	19.7	500	3.03	77	3.20	81	21.25	540	16	50.0	816	370

\*14 and 16" valves 250 PSI CWP

**FREEZING WEATHER PRECAUTION:** Subsequent to testing a piping system, gate valve should be in an open position to allow complete drainage.

\*Weighted average lead content ≤ 0.25%

# 175 PSI WWP Iron Body Gate Valves

Fire Protection Post Indicator Valve • Bolted Bonnet • Indicator Post Pattern  
• Non-Rising Stem • Solid Wedge

## 175 PSI/12.1 Bar Non-Shock Cold Water

UL/ULC LISTED\* • FM APPROVED

### MATERIAL LIST

PART	SPECIFICATION
1. Nut	Steel ASTM A307
2. Square Oper. Nut	Cast Iron ASTM A126 Class B
3. Stem	Brass ASTM B16 Alloy C36000
4. Ind. Post Flange Nut	Steel ASTM A307
5. Ind. Post Flange	Cast Iron ASTM A126 Class B
6. Ind. Post Flange Bolt	Steel ASTM A307
7. O-Ring Seal	Buna-N Rubber
8. Bonnet	Cast Iron ASTM A126 Class B
9. Ind. Post Flange Gasket	Non Asbestos
10. Body Bolt	Steel ASTM A307
11. Body Gasket	Non Asbestos
12. Body Nut	Steel ASTM A307
13. Body	Cast Iron ASTM A126 Class B
*14. Wedge Bushing	Cast Bronze B584 Alloy C84400
15. Wedge	Cast Iron ASTM A126 Class B
16. Wedge Face Ring	Cast Bronze B584 Alloy C84400
17. Seat Ring	Cast Bronze B584 Alloy C84400

\* Sizes 8", 10" and 12" only

NOTES: Flanged valve is consistent with ANSI B16.1 Class 125.  
Post Flange has a 12 OD and 10.5" bolt circle.

\* Compliance with the Standard for Gate Valves for Fire Protection Service, UL 262, and the Canadian Requirements, ULC/ORD-C262.

### DIMENSIONS—WEIGHTS—QUANTITIES

F-609 Dimensions													
Size	A		B		C		D		E		Weight		
In. mm.	In.	mm.	In.	mm.	In.	mm.	In.	mm.	In.	mm.	Lbs.	Kg.	
4	100	9.00	229	14.13	359	9.00	229	.94	24	3.66	93	105	48
6	150	10.50	267	18.56	471	11.00	279	1.00	25	3.44	87	170	77
8	200	11.50	292	22.13	562	13.50	343	1.13	29	4.00	102	277	125
10	250	13.00	330	25.75	654	16.00	406	1.19	30	3.88	98	399	181
12	300	14.00	356	29.50	749	19.00	483	1.25	32	4.94	125	623	283

  

M-609 Dimensions													
Size	A		B		C		D		E		Weight		
In. mm.	In.	mm.	In.	mm.	In.	mm.	In.	mm.	In.	mm.	Lbs.	Kg.	
4	100	9.25	235	14.13	359	9.00	229	1.00	25	3.66	93	100	45
6	150	10.75	273	18.56	471	11.09	282	1.03	26	2.25	57	153	69
8	200	11.50	292	22.13	562	13.31	338	1.09	28	4.00	102	250	113
10	250	13.00	330	25.75	654	15.63	397	1.13	29	3.88	98	390	176
12	300	14.00	356	29.50	749	18.00	457	1.25	32	4.94	125	556	253



**F-609**  
Flanged

**M-609**  
Mechanical

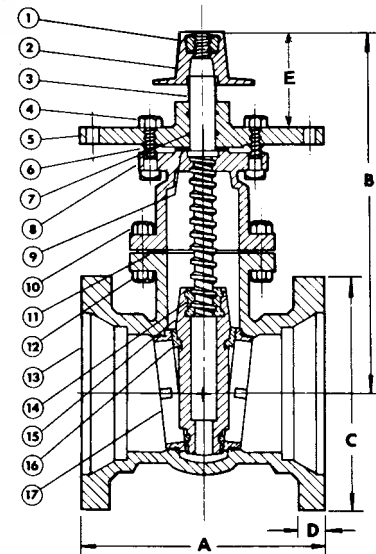

**M-609**  
MJ x MJ

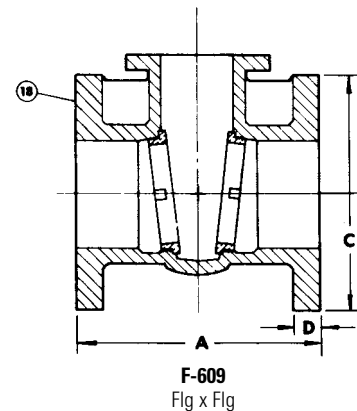

**F-609**  
Flg x Flg

**FREEZING WEATHER PRECAUTION:** Subsequent to testing a piping system, gate valve should be in an open position to allow complete drainage.

**NOTE:** Number of turns required to open 4", 9", 6", 13½", 8", 17½", 10", 30¼", 12", 38¼ turns.  
Tolerance ± ½ turn on all sizes.

**NOTE:** Available to ISO Flange dimensions. Specify F-609-I. See page 51.



# 300 PSI CWP Iron Body Gate Valves

Fire Protection Post Indicator Valve • Bolted Bonnet • Indicator Post Pattern  
• Non-Rising Stem • Resilient Wedge • Epoxy Coated Interior/Exterior

**300 PSI/20.6 Bar Non-Shock Cold Working Pressure**

UL/ULC LISTED • FM APPROVED • AWWA C509 & 515  
CERTIFIED LEAD-FREE\* BY IAPMO R&T TO NSF/ANSI 372



**F-609-RWS**  
Flanged



**M-609-RWS**  
Mechanical

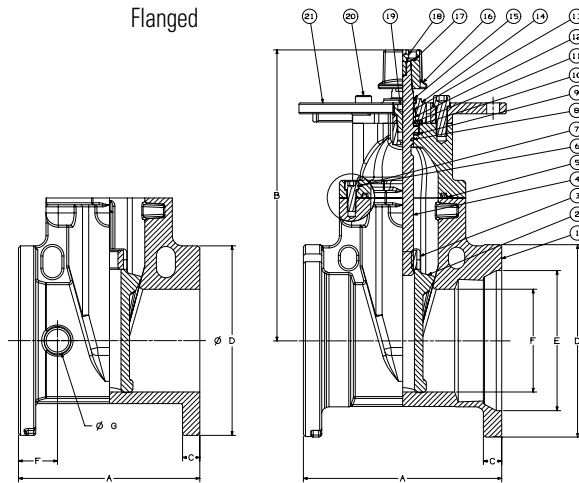

**F-609-RWS**  
Flg x Flg

**M-609-RWS**  
MJ x MJ

## MATERIAL LIST

PART	SPECIFICATION
1 Valve Body	Ductile Iron ASTM A536
2 Resilient Wedge	Ductile Iron ASTM A536 / EPDM ASTM D2000
3 Wedge Nut	ASTM B584 UNS C83600
4 Stem	Stainless Steel 304
5 Bonnet Gasket	EPDM ASTM D2000
6 Bonnet Screw	Corrosion-resistant Steel
7 Bonnet	Ductile Iron ASTM A536
8 Stem Primary O-Ring	EPDM ASTM D2000
9 Stem Thrust Washer (lower)	Bronze ASTM B584 UNS C83600
10 Stem Thrust Washer (upper)	Stainless Steel ASTM A276 UNS S41000
11 Gland Seal O-Ring	EPDM ASTM D2000
12 Stem Seal Bushing	ASTM B584 UNS C83600
13 Stem Secondary O-Ring	EPDM ASTM D2000
14 Gland Flange	Ductile Iron ASTM A536
15 Stem Ring Wiper	EPDM ASTM D2000
16 Square Operating Nut	Cast Iron ASTM A126-B
17 Operating Nut Washer	ASTM A276 SS304
18 Operating Nut Screw	Alloy Steel ASTM A574M Zinc Plated
19 Gland Flange Screw	Alloy Steel ASTM A574M Zinc Plated
20 Indicator Flange Screw	Alloy Steel ASTM A574M Zinc Plated
21 Indicator Post Flange	Cast Iron ASTM A126-B
22 UL/FM Label (not shown)	Aluminium
23 Drive Screw, Label (not shown)	Stainless Steel 304

Coating — Electrostatically applied fusion-bonded epoxy 8-20 mil. inside and outside.  
Meets or exceeds AWWA C550.

NOTE: Flanged valve is consistent with ANSI B16.1 Class 125.

## DIMENSIONS—WEIGHTS—QUANTITIES

M-609-RW Dimensions													Bolt					
Size	A		B		C		D		E		F		Circle	Flange	Turns	Weight		
In. mm.	In.	mm.	In.	mm.	In.	mm.	In.	mm.	In.	mm.	In.	mm.	In.	mm.	Holes	To Open	Lbs.	Kg.
4 100	10.0	254	13.5	344	1.00	26	9.1	232	6.0	153	3.9	100	7.50	191	4	12.5	72	33
6 150	11.5	292	17.4	441	1.06	27	11.1	283	8.1	206	5.9	150	9.50	241	6	15.0	101	46
8 200	11.5	292	20.8	529	1.12	28	13.4	340	10.3	261	7.9	200	11.75	298	6	16.7	148	67
10 250	13.0	330	24.2	614	1.18	30	15.7	400	12.3	313	9.8	250	14.00	356	8	20.8	236	107
12 300	14.0	356	27.0	700	1.25	32	18.0	456	14.4	367	11.8	300	16.25	413	8	25.0	353	160

F-609-RW Dimensions													Bolt					
Size	A		B		C		D		F		G		Circle	Flange	Turns	Weight		
In. mm.	In.	mm.	In.	mm.	In.	mm.	In.	mm.	In.	mm.	In.	mm.	In.	mm.	Holes	To Open	Lbs.	Kg.
4 100	9.0	229	13.5	344	0.94	24.0	9.0	229	2.13	54	1.42	36	7.50	191	8	12.5	75	34
6 150	10.5	267	17.4	441	1.00	25.4	11.0	279	2.24	57	1.54	39	9.50	241	8	15.0	106	48
8 200	11.5	292	20.8	529	1.13	28.6	13.5	343	2.48	63	1.54	39	11.75	298	8	16.7	163	74
10 250	13.0	330	24.2	614	1.19	30.2	16.0	406	3.15	65	1.82	46	14.25	362	12	20.8	256	116
12 300	14.0	356	27.0	700	1.25	31.8	19.0	483	2.91	74	1.82	46	17.00	432	12	25.0	394	181

**FREEZING WEATHER PRECAUTION:** Subsequent to testing a piping system, gate valve should be in an open position to allow complete drainage.

\*Weighted average lead content ≤ 0.25%

# 300 PSI CWP Iron Body Gate Valves

Fire Protection Post Indicator Valve • Bolted Bonnet • Indicator Post Pattern  
• Non-Rising Stem • Resilient Wedge • Epoxy Coated Interior/Exterior

**300 PSI/20.6 Bar Non-Shock Cold Working Pressure**  
**(160° F/71° C max. operating temperature)**

UL/ULC LISTED • FM APPROVED • AWWA C509 & 515  
CERTIFIED LEAD-FREE\* BY IAPMO R&T TO NSF/ANSI 372



**FM609-RWS**  
Flanged x Mechanical Joint

## MATERIAL LIST

PART	SPECIFICATION
1 Valve Body	Ductile Iron ASTM A536
2 Resilient Wedge	Ductile Iron ASTM A536 / EPDM ASTM D2000
3 Wedge Nut	ASTM B584 UNS C83600
4 Stem	Stainless Steel 304
5 Bonnet Gasket	EPDM ASTM D2000
6 Bonnet Screw	Corrosion-resistant Steel
7 Bonnet	Ductile Iron ASTM A536
8 Stem Primary O-Ring	EPDM ASTM D2000
9 Stem Thrust Washer (lower)	Bronze ASTM B584 UNS C83600
10 Stem Thrust Washer (upper)	Stainless Steel ASTM A276 UNS S41000
11 Gland Seal O-Ring	EPDM ASTM D2000
12 Stem Seal Bushing	ASTM B584 UNS C83600
13 Stem Secondary O-Ring	EPDM ASTM D2000
14 Gland Flange	Ductile Iron ASTM A536
15 Stem Ring Wiper	EPDM ASTM D2000
16 Square Operating Nut	Cast Iron ASTM A126-B
17 Operating Nut Washer	ASTM A276 SS304
18 Operating Nut Screw	Alloy Steel ASTM A574M Zinc Plated
19 Gland Flange Screw	Alloy Steel ASTM A574M Zinc Plated
20 Indicator Flange Screw	Alloy Steel ASTM A574M Zinc Plated
21 Indicator Post Flange	Cast Iron ASTM A126-B
22 UL/FM Label (not shown)	Aluminium
23 Drive Screw, Label (not shown)	Stainless Steel 304

Coating — Electrostatically applied fusion-bonded epoxy 8-20 mil. inside and outside.  
Meets or exceeds AWWA C550.

NOTE: Flanged valve is consistent with ANSI B16.1 Class 125.

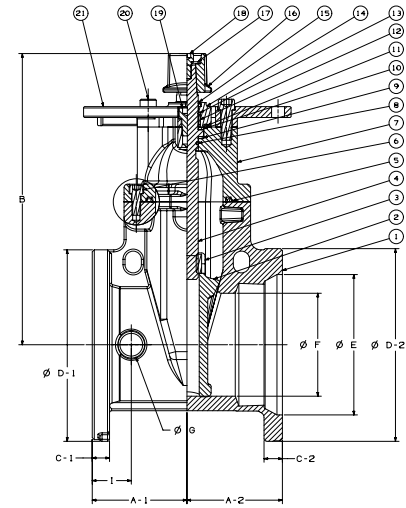

**FM609-RWS**  
Flg x MJ

## DIMENSIONS—WEIGHTS—QUANTITIES

Size	Dimensions																
	A-1		A-2		B		C-1		C-2		D-1		D-2		E		F
In. mm.	In. mm.	In. mm.	In. mm.	In. mm.	In. mm.	In. mm.	In. mm.	In. mm.	In. mm.	In. mm.	In. mm.	In. mm.	In. mm.	In. mm.	In. mm.	In. mm.	In. mm.
4	100	4.75 115	4.75 127	13.50 344	0.94 24	1.00 26	9.00 229	9.10 232	6.00 153	3.90 100							
6	150	5.50 134	5.50 146	17.00 441	1.00 25	1.06 27	11.00 279	11.10 283	8.10 206	5.90 150							
8	200	5.75 146	5.75 146	20.75 529	1.13 29	1.12 28	13.50 343	13.40 340	10.30 261	7.90 200							
10	250	6.50 165	6.50 165	24.00 614	1.19 30	1.18 30	16.00 406	15.60 397	12.30 313	9.80 250							
12	300	7.00 178	7.00 179	27.00 700	1.25 32	1.25 32	19.00 486	17.90 454	14.40 367	11.80 300							

Size	G		I		Flanged B.C.		MJ B.C.		No. Holes Flanged	No. Holes M-Joint	Turns To Open	Weight	
	In. mm.	In. mm.	In. mm.	In. mm.	In. mm.	In. mm.	Lbs.	Kg.					
4	100	1.42 54	2.13 54	7.50 191	7.50 191	8	4	12.5	72	33			
6	150	1.54 64	2.24 57	9.50 241	9.50 241	8	6	15.0	103	47			
8	200	1.54 70	2.48 63	11.75 296	11.75 298	8	6	16.7	99	45			
10	250	1.82 70	3.15 65	14.25 362	14.00 356	12	8	20.8	247	112			
12	300	1.82 86	2.91 74	17.01 432	16.25 413	12	8	25.0	377	171			

**FREEZING WEATHER PRECAUTION:** Subsequent to testing a piping system, gate valve should be in an open position to allow complete drainage.

\*Weighted average lead content ≤ 0.25%

# Indicator Posts

Fire Protection • Upright Posts • For use with non-rising stem indicator post style gate valves

UL LISTED • FM APPROVED

## MATERIAL LIST

PART	SPECIFICATION
1. Locking Wrench	Cast Iron ASTM A126 Class B
2. Operating Nut	Bronze ASTM A584 Alloy 83600
3. Retainer Ring	Nitrile
4. Upper Body	Cast Iron ASTM A126 Class B
5. Window	Lexan-UV Stabilized
6. "Open" Target	Cast Aluminum
7. "Shut" Target	Cast Aluminum
8. Pipe Plug 1/2" NPT	Steel - Zinc Plated
9. Eye Bolt	Steel
10. Operating Rod	H.R. Steel ANSI M1020
11. Target Carrier Nut	Bronze ASTM B854 Alloy 83600
12. Target Carrier Plate	Steel
13. Target Retainer Clamp	Stainless Steel Type 302
14. Hex Nut	Steel - Zinc Plated
15. Pan Head Screw	Steel - Zinc Plated
16. Hex Head Screw	Steel - Zinc Plated
17. Spacer Sleeve	Ductile Iron
18. Body - Outer	Ductile Iron
19. Body - Inner	Ductile Iron
20. Hex Head Screw	Steel - Zinc Plated
21. Operator Rod Coupling	Cast Iron ASTM A126 Class B
22. Cotter Pin	Brass
23. Hex Head Screw	Steel - Zinc Plated
24. Base Flange	Cast Iron ASTM A126 Class B
25. Hex Head Screw	Steel - Zinc Plated
26. Hex Nut	Steel - Zinc Plated

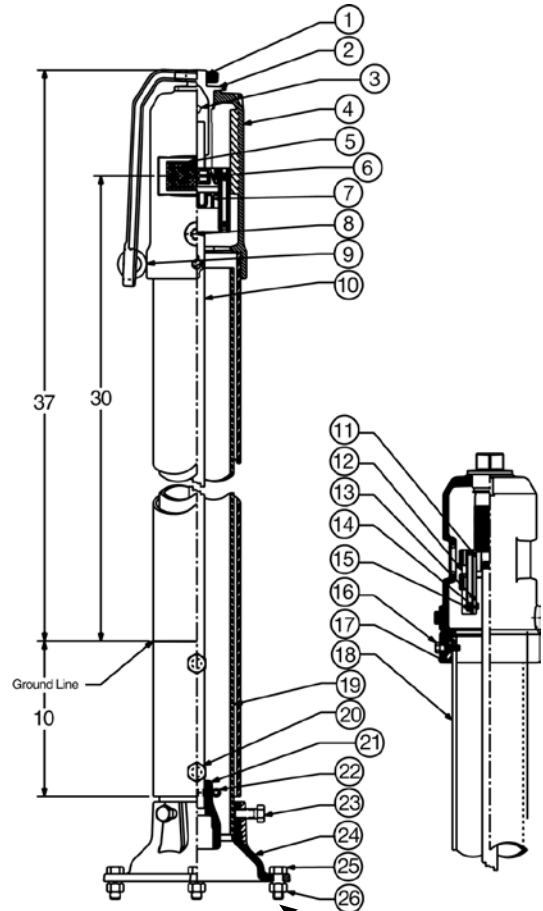

**NIP-1AJ**  
Upright Post

(4) Holes .75 drill on 10 1/2" bolt circle. Diameter drilled on center.\*

### NIBCO Fig. No. NIP-1AJ

Mated to NIBCO IBBM Gate Valves

### Bury Depth Dimensions from bottom of trench (Inches - Rounded)\*

Valve Size**	Min. Bury Depth			Max. Bury Depth		
	NIP-1AJ	NIP-1AJE	NIP-1AJEE	NIP-1AJ	NIP-1AJE	NIP-1AJEE
4"	33"	51"	59"	52"	70"	88"
6"	40"	58"	76"	59"	77"	95"
8"	43"	61"	79"	62"	80"	98"
10"	48"	66"	84"	67"	85"	103"
12"	52"	70"	88"	71"	89"	107"

Note: Add 18" Bury Depth for NIP-1AJE

Add 36" Bury Depth for NIP-1AJEE

Special lengths available in 6" increments, P.O.A. beyond NIP-1AJEE

\* Mounting hardware included

### Indicator Post Gate Valve Dimensions

Valve Size	F/M609 (IBBM)	4"		6"		8"		10"		12"	
		In.	mm.	In.	mm.	In.	mm.	In.	mm.	In.	mm.
Dimension from centerline of valve to top of the operating nut	F/M609 (IBBM)	14.1	358	18.6	472	22.1	561	25.8	655	29.5	749
	F/M609RW	13.5	342	17.0	432	20.5	520	23.8	605	27.0	686
Turns to open (+.5 turn)	F/M609 (IBBM)	9		13.5		17.5		30.25		38.25	
	F/M609RW	12.8		15		17.6		21.2		25.1	





# Indicator Posts

Fire Protection • Wall Post • For use with non-rising stem indicator post style gate valves

UL LISTED • FM APPROVED

## MATERIAL LIST

PART	SPECIFICATION
1. Eye Bolt	Steel - Zinc Plated
2. Nut	Steel - Zinc Plated
3. Washer	Steel - Zinc Plated
4. Handwheel	Cast Iron
5. Retainer O-Ring	Nitrile
6. Operating Stem Nut	Bronze ASTM B584 Alloy 864
7. Upper Body	Cast Iron ASTM A126 Class B
8. Target Carrier Nut	Bronze ASTM B584 Alloy 864
9. Window	Lexan-UV Stabilized
10. Target Carrier Plate (2)	Steel Plated
11. Open Target (2)	Cast Aluminum
12. Shut Target (2)	Cast Aluminum
13. Clamp Target Retainer (4)	302 SS
14. Hex Nut (8)	Steel - Zinc Plated
15. Pan Head Screw (8)	Steel - Zinc Plated
16. Pipe Plug	Malleable Iron
17. Operator Rod	Steel
18. Cotter Pin	Brass
19. Operator Rod Coupling	Cast Iron ASTM A126 Class B
20. Eye Bolt	Forged Steel
21. Hex Head Screw	Steel - Zinc Plated
22. Base Flange	Cast Iron ASTM A126 Class B

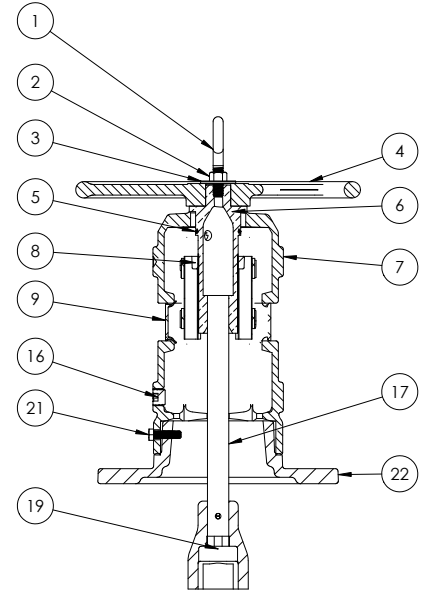

**NIP-3AJ**  
Wall Post

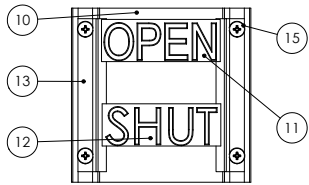

Weight includes operator rod and coupling

	Lbs.	Kg.
NIP-1AJ - Upright Adjustable Post	150	68
NIP-3AJ - Wall Post	73	33

Note: 63" long 1" square operator rod supplied with NIP-1AJ and  
32" long 1" square operator rod supplied with NIP-3AJ

\* Mounting hardware included

## Indicator Post Gate Valve Dimensions

Valve Size	4"		6"		8"		10"		12"			
	ln.	mm.	ln.	mm.	ln.	mm.	ln.	mm.	ln.	mm.		
Dimension from centerline of valve to top of the operating nut	F/M609 (IBBM)	14.1 358	18.6 472	22.1 561	25.8 655	29.5 749	F/M609RW	13.5 342	17.0 432	20.5 520	23.8 605	27.0 686
Turns to open (±.5 turn)	F/M609 (IBBM)	9	13.5	17.5	30.25	38.25	F/M609RW	12.8	15	17.6	21.2	25.1

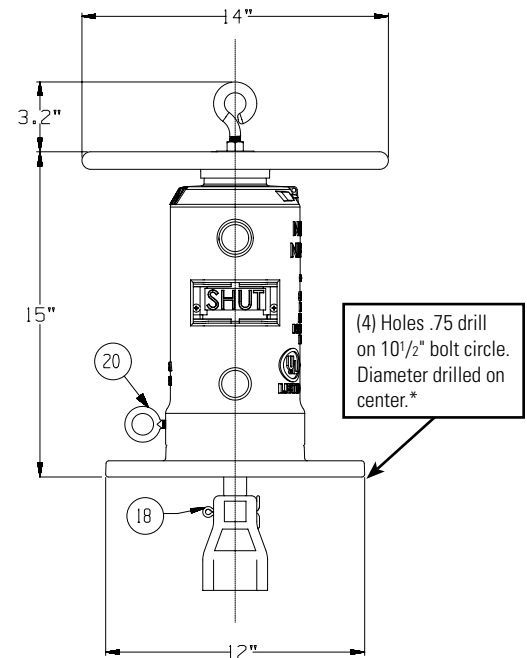

# Lead-Free\* 250 PSI CWP Iron Body Grooved Silent Check Valves

Fire Protection • Twin Disc • Grooved Style • Bronze Disc • Nitrile • Spring Actuated

**250 PSI/17.2 Bar Non-Shock Cold Working Pressure**  
**Maximum Temperature to 180°F/82°C @ 220 PSI/15 Bar**

CERTIFIED LEAD-FREE\* BY WQA TO NSF/ANSI 372  
CONFORMS TO ANSI/AWWA C606 FOR STEEL IPS PIPE  
• UL/ULC LISTED • FM APPROVED



**C USA**  
**COMPONENT LEAD-FREE**

## MATERIAL LIST

PART	SPECIFICATION
1. Body	Ductile Iron ASTM A536 Grade 65-45-12 w/Buna-N (Nitrile) resilient seat molded to body
2. Disc	Bronze ASTM B584 Alloy C87600
3. Torsion Spring	Stainless Steel UNS 31600 ASTM A313
4. Disc Hinge Pin	Stainless Steel UNS 31600 ASTM A276
5. Disc Stop Pin	Stainless Steel UNS 31600 ASTM A276
6. Disc Thrust Bearing	Stainless Steel UNS 31600 ASTM A240
7. Hinge Pin Retainer	Stainless Steel UNS 31600
8. Stop Pin Retainer	Stainless Steel UNS 31600
9. Stabilization Sphere	Buna-N
10. Spacer	Stainless Steel UNS 31600 ASTM A276



**KG-900-W-LF**  
Grooved

Sizes 10" and 12" furnished with lifting eyebolt

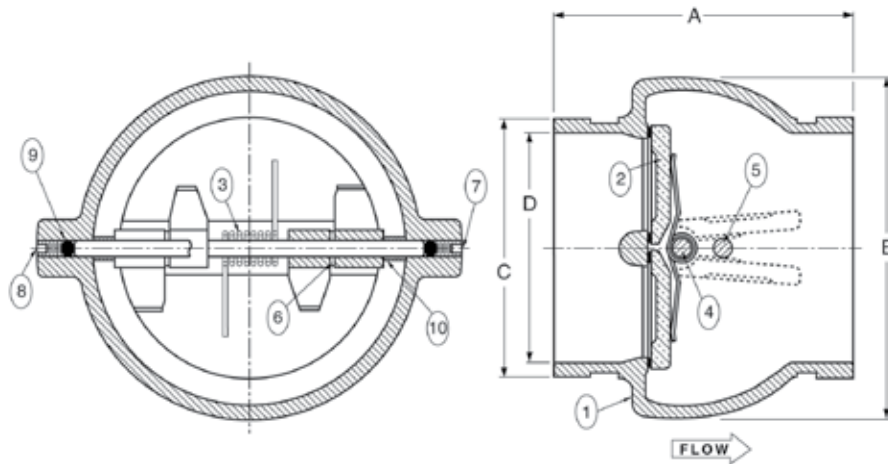

## DIMENSIONS—WEIGHTS—QUANTITIES

Size	Dimensions								KG-920-W-LF		
	A		B		C		D		Lbs.	Kg.	
In. mm.	In.	mm.	In.	mm.	In.	mm.	In.	mm.			
2½	65	4.91	125	4.88	124	2.88	73	2.41	61	4.50	2.04
3	80	5.31	135	5.38	137	3.50	89	2.94	75	7.30	3.31
4	100	5.38	137	6.00	152	4.50	114	3.91	99	8.60	3.90
5	125	5.72	145	7.06	179	5.56	141	4.89	124	13.00	5.90
6	150	6.00	152	8.13	206	6.63	168	5.92	150	18.00	8.17
8	200	6.72	171	10.03	255	8.63	219	7.91	201	30.00	13.6
10	250	7.78	198	12.38	314	10.75	273	10.00	254	56.00	25.4
12	300	8.19	208	14.38	365	12.75	324	11.94	303	81.80	36.7

**NOTE:** Twin Disc Check Valves can be installed horizontally or in the vertical position with flow up.

**CAUTION:** For horizontal flow applications, the valve must be installed with disc hinge pin in the vertical position to insure proper operation.

**WARNING:**

- These are not to be used as steam valves
- Valves are not to be used near a reciprocating air compressor
- Install 5 pipe diameters minimum downstream from pump discharge or elbows to avoid flow turbulence. Flow straighteners may be required in extreme cases.

**NOTE:** On pump discharge, the preferred check valves are in-line spring loaded.

Groove dimensions conform to ANSI/AWWA specification C606 Table 4 (Cut Groove Dimensions)



\*Lead Free refers to the wetted surface of pipe, fittings and fixtures in potable water systems that have a weighted average lead content ≤ 0.25% per the Safe Drinking Water Act (Sec. 1417) amended 1-4-2011 and other equivalent state regulations.

# 350 PSI CWP Iron Body Grooved Silent Check Valve

Fire Protection • Twin Disc • Grooved Style • Bronze Disc • Nitrile • Spring Actuated

**350 PSI/24 Bar Non-Shock Cold Working Pressure**  
**Maximum Temperature to 180°F/82°C @ 220 PSI/15 Bar**

CERTIFIED LEAD-FREE\* BY WQA TO NSF/ANSI 372  
CONFORMS TO ANSI/AWWA C606 FOR STEEL IPS PIPE  
• UL/ULC LISTED

## MATERIAL LIST

PART	SPECIFICATION
1. Body	Ductile Iron ASTM A536 Grade 65-45-12 w/Buna-N (Nitrile) resilient seat molded to body
2. Disc	Bronze ASTM B584 Alloy C83600
3. Torsion Spring	Stainless Steel UNS 31600 ASTM A313
4. Disc Hinge Pin	Stainless Steel UNS 31600 ASTM A276
5. Disc Stop Pin	Stainless Steel UNS 31600 ASTM A276
6. Disc Thrust Bearing	Stainless Steel UNS 31600 ASTM A240
7. Hinge Pin Retainer	Stainless Steel UNS 31600
8. Stop Pin Retainer	Stainless Steel UNS 31600 I
9. Stabilization Sphere	Buna-N
10. Spacer	Stainless Steel UNS 31600 ASTM A276

Size 10" furnished with lifting eyebolt



**KG-900-W-LF 350**  
Grooved

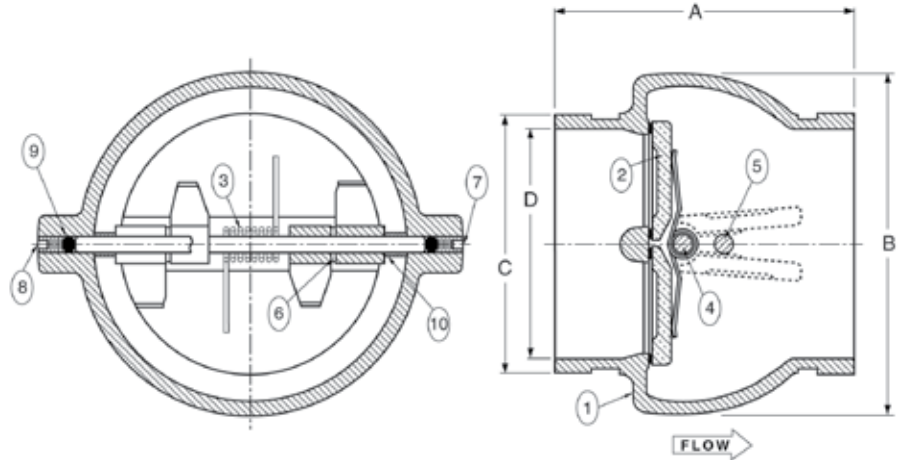

## DIMENSIONS—WEIGHTS—QUANTITIES

Size	Dimensions								KG-900-W 350		
	A		B		C		D		Lbs.	Kg.	
In. mm.	In.	mm.	In.	mm.	In.	mm.	In.	mm.			
2½	65	4.91	125	4.88	124	2.88	73	2.41	61	4.50	2.04
3	80	5.31	135	5.38	137	3.50	89	2.94	75	7.30	3.31
4	100	5.38	137	6.00	152	4.50	114	3.91	99	8.60	3.90
6	150	6.00	152	8.13	206	6.63	168	5.92	150	18.00	8.17
8	200	6.72	171	10.03	255	8.63	219	7.91	201	30.00	13.60
10	250	7.78	198	12.38	314	10.75	273	10.00	254	56.00	25.40

**NOTE:**

Twin Disc Check Valves can be installed horizontally or in the vertical position with flow up.

**CAUTION:**

For horizontal flow applications, the valve must be installed with disc hinge pin in the vertical position to insure proper operation.

**WARNING:**

1. These are not to be used as steam valves
2. Valves are not to be used near a reciprocating air compressor
3. Install 5 pipe diameters minimum downstream from pump discharge or elbows to avoid flow turbulence. Flow straighteners may be required in extreme cases.

**NOTE:**

On pump discharge, the preferred check valves are in-line spring loaded.

Groove dimensions conform to ANSI/AWWA specification C606 Table 4 (Cut Groove Dimensions)



\*Lead Free refers to the wetted surface of pipe, fittings and fixtures in potable water systems that have a weighted average lead content ≤ 0.25% per the Safe Drinking Water Act (Sec. 1417) amended 1-4-2011 and other equivalent state regulations.

# Lead-Free\* 250 PSI WWP Iron Body Check Valves

Fire Protection Valve • UL listed FM Approved  
Double-Door • Wafer Style • Rubber Seat • Spring Actuated

CERTIFIED LEAD-FREE\* BY WQA TO NSF/ANSI 372  
UL/ULC LISTED • FM APPROVED\*



**C USA**  
**COMPONENT LEAD-FREE**

MATERIAL LIST	
PART	SPECIFICATION
1. Body	Ductile Iron ASTM A536, Grade 65-45-12 - 2" thru 12" 14" thru 16" Cast Iron ASTM 126, Class B w/ Buna-N (Nitrile) resilient seat molded to body
2. Disc	Bronze ASTM B584 Alloy C87600 (2½" - 12") Aluminum Bronze ASTM B148, C95200 (14"-16")
3. Torsion Spring	Stainless Steel UNS 31600 ASTM A313
4. Hinge Pin	Stainless Steel UNS 31600 ASTM A276
5. Stop Pin	Stainless Steel UNS 31600 ASTM A276
6. Thrust Bearing	Stainless Steel UNS 31600 ASTM A240
7. Hinge Pin Retainer	Stainless Steel UNS 31600
8. Stop Pin Retainer	Stainless Steel UNS 31600
9. Stabilization Sphere	Buna-N
10. Spacer	Stainless Steel UNS S31600 ASTM A276



**KW-900-W-LF**  
Wafer Style  
2½" - 12"

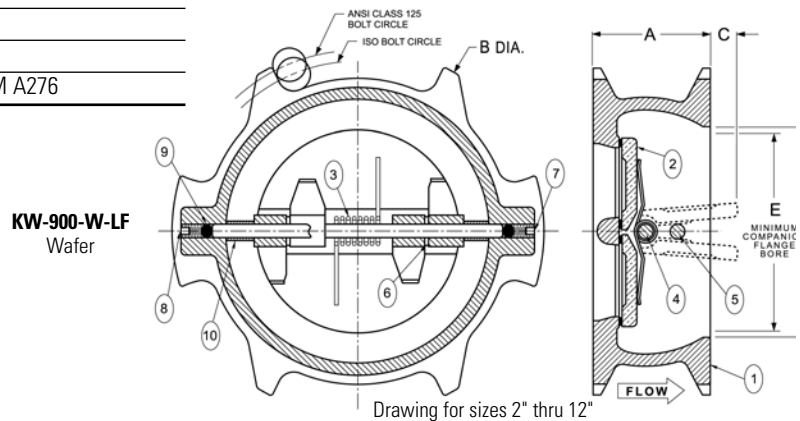

## DIMENSIONS—WEIGHTS—QUANTITIES

Size	Dimensions										Weight		
	A		B		C		D		E		C/V	Lbs.	Kg.
In. mm.	In.	mm.	In.	mm.	In.	mm.	In.	mm.	In.	mm.			
2½ 65	2.38	60	6.00	152	.125	3	3.50	89	1.313	33	108	4.3	1.95
3 80	2.63	67	5.63	143	.188	5	3.875	98	1.688	43	178	6.1	2.77
4 100	2.63	67	7.75	197	.625	16	4.75	121	3.063	78	440	8.8	3.99
5 125	3.25	83	7.56	192	.813	21	5.50	140	3.625	92	560	13.0	5.90
6 150	3.75	95	8.63	219	.813	21	6.25	159	4.250	108	840	18.0	8.16
8 200	5.00	127	12.25	311	1.000	25	8.00	203	5.500	140	1600	37.0	16.78
10 250	5.50	140	14.75	375	2.060	54	10.25	257	8.500	216	2700	65.0	29.48
12 300	7.13	181	17.38	441	1.938	49	12.00	305	9.250	235	4700	94.0	42.64
14 350	7.25	184	17.75	451	3.250	83	14.38	—	12.500	330	5200	200.0	90.75
16 400	7.50	191	20.25	514	4.500	114	16.38	—	15.000	381	7200	285.0	129.28

\*Note: 14" and 16" sizes, 200 PSI WWP, FM approved only – P.O.A.

### Features

- Spring loaded for fast closure, eliminating reverse flow slam and water hammer.
- Easily installed, with gasket, between standard class 125 flanges.
- Only one set of flange studs is needed.
- May be installed in both horizontal and vertical lines with upward flow.

### NOTE:

Twin Disc Check Valves can be installed horizontally or in the vertical position with flow up.

### CAUTION:

For horizontal flow applications, the valve must be installed with disc hinge pin in the vertical position to insure proper operation.

### WARNING:

1. These are not to be used as steam valves
2. Valves are not to be used near a reciprocating air compressor
3. Install 5 pipe diameters minimum downstream from pump discharge or elbows to avoid flow turbulence. Flow straighteners may be required in extreme cases.

### NOTE:

On pump discharge, the preferred check valves are in-line spring loaded.



**KW-900-W-LF**  
Wafer Style  
14" - 16"



# 175 PSI WWP Iron Body Check Valves

Fire Protection Valve • Bolted Bonnet • Horizontal Swing • Renewable Seat and Disc •  
Drilled and Tapped for Ball Drip Outlet

## 175 PSI/12.1 Bar Non-Shock Cold Water

CONFORMS TO MSS SP-71 • UL/ULC LISTED\*  
• FM APPROVED • APPROVED BY THE NEW YORK CITY  
B.S.A. 143-69-SA



**F-908-W**  
Flanged

### MATERIAL LIST

PART	SPECIFICATION
1. Pipe Plug	Cast Iron or Steel
2. Bonnet	Cast Iron ASTM A126 Class B
3. Bonnet Gasket	Non Asbestos
4. Bonnet Bolt and Nut	Steel ASTM A307
5. Hinge Plug	Cast Bronze B584 Alloy C84400 (not shown)
6. Hinge Pin	Brass ASTM B16
7. Disc Hanger Nut	Cast Bronze B584 Alloy C84400
8. Disc Stud Bolt	Brass ASTM B16 Alloy C36000
9. Disc Cage	Cast Iron ASTM A126 Class B or Malleable Iron ASTM A 47 (not shown)
10. Disc Plate	Cast Bronze B584 Alloy C84400
11. Disc Hanger	Cast Bronze B584 Alloy C84400
12. Disc Nut	Brass ASTM B16 Alloy C36000
13. Seat Ring	Cast Bronze B584 Alloy C84400
14. Disc	Rubber (W)
15. Body	Cast Iron ASTM A126 Class B

**NOTE:** Sizes 2½, 3, 5, & 10 are manufactured, listed and approved by Kennedy Valve and distributed by NIBCO.

Material list applies to sizes 4", 6", 8", 12" only.  
All sizes are drilled and tapped ¾" at Boss "C" for ball drip.

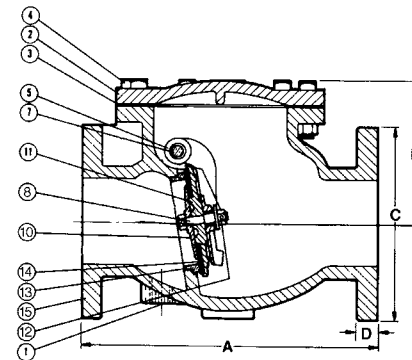

**F-908-W**  
Flg x Flg

### DIMENSIONS—WEIGHTS—QUANTITIES

Size	Dimensions								Weight	
	A		B		C		D		Lbs.	Kg.
In. mm.	In.	mm.	In.	mm.	In.	mm.	In.	mm.		
2½ 65	10.00	254	6.44	164	7.00	178	.69	17	53	24
3 80	10.25	260	6.63	168	7.50	191	.75	19	62	28
4 100	13.00	330	8.00	203	9.00	229	.94	24	103	47
5 125	15.00	381	9.19	233	10.00	254	1.00	25	145	66
6 150	16.25	413	10.31	262	11.00	279	1.00	25	174	79
8 200	19.50	495	11.50	292	13.50	343	1.13	29	290	132
10 250	22.00	559	13.31	338	16.00	406	1.19	30	490	223
12 300	27.50	699	15.56	395	19.00	483	1.25	32	683	310

NIBCO Iron Body check valves may be installed in both horizontal and vertical lines with upward flow.

\* Compliance with the Canadian Requirements per ULC Subject 312 and the Standard for Check Valves, UL 312.



Ball Drip

An automatic ball drip is available for NIBCO Underwriter's check valves. The ball drip is installed at boss location "C" on the check valve of the fire department connection. It will close against pressure, but will open when pressure is off allowing water to drain from the fire department connection.

¾" Ball Drip # RG 22100  
90° Street Elbow #T046227 PP



# 250 PSI WWP Iron Body Check Valves

Reliable Automatic Sprinkler "G" Series Fire Protection Valve • Drilled & Tapped for Ball Drip Outlet • EPDM Seal • Bronze Seat • Stainless Steel Disc & Spring Actuated

## 250 PSI/17.2 Bar Non-Shock Cold Water

GROOVES CONFORM TO ANSI AWWA C-606 FOR STEEL PIPE • UL/ULC LISTED • FM APPROVED • APPROVED BY THE NEW YORK CITY MEA 258-93-E

### MATERIAL LIST

PART	SPECIFICATION
*1. Valve Body	Cast Iron, ASTM A48 Class 30A
2. Seat	Bronze C83600 or C93200, ASTM B505
3. Clapper	Stainless Steel 304, ASTM A240
**4. Facing Seal	EPDM Rubber
5. Clamping Ring	Stainless Steel 304, ASTM A240
**6. Gasket	EPDM Rubber
7. Spring	Stainless Steel 302, ASTM A313
8. Hinge Pin	Stainless Steel 303, ASTM A582
9. Bolt	Stainless Steel 304, ASTM F593
**10. Locknut	Stainless Steel 303, ASTM F594
11. Plug 1/8" NPT	Steel
12. Plug 1/2" NPT	Steel

\* Not field replaceable.

\*\* Replacement seal kit.

NOTE: All sizes are manufactured, listed and approved by Automatic Sprinkler and distributed by NIBCO.

All sizes drilled and tapped 1/2" for a ball drip.



**G-917-W (Reliable "G" Series)**  
Grooved

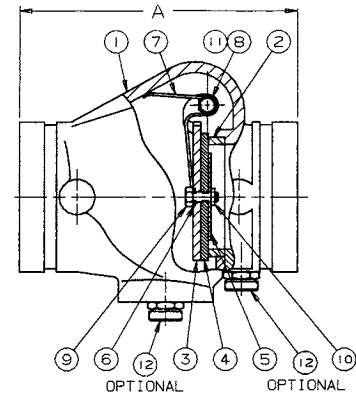

G-917-W



Ball Drip

An automatic ball drip is available for NIBCO Underwriter's check valves. The ball drip is installed at boss location "C" on the check valve of the fire department connection. It will close against pressure, but will open when pressure is off allowing water to drain from the fire department connection.

1/2" Ball Drip # RG 22000

90° Street Elbow #T046212 PP

### DIMENSIONS—WEIGHTS—QUANTITIES

Size		Dimension A		Weight	
In.	mm.	In.	mm.	Lbs.	Kg.
2½	65	7.03	179	9	4
3	80	7.62	194	11	5
4	100	8.44	214	17	8
6	150	10.25	260	38	17



# Hi Rise Valves Illustrated Index

Ductile Iron Body Gate Valve  
Outside screw and yoke  
Bronze Trim, Solid Wedge  
285 PSI WWP



**F-637-31**  
Sizes 2" thru 12"  
Class 150 Flanged-Raised Face  
**Page 33**

Iron Body Gate Valve  
Outside screw and yoke  
Bronze Trim, Solid Wedge  
500 PSI WWP



**F-667-0**  
Sizes 2" thru 12"  
Class 250 Flanged Ends  
**Page 34**

UL - FM Approved  
Iron Body Gate Valve  
Outside screw and yoke  
Bronze Trim, Solid Wedge  
350 PSI WWP UL/300 PSI WWP FM



**F-697-0**  
Sizes 2 1/2" thru 10"  
Class 250 Flanged Ends  
**Page 35**

Ductile Iron Body Swing Check Valve  
Bronze Trim  
285 PSI WWP



**F-938-31**  
Sizes 2" thru 12"  
Class 150 Flanged-Raised Face  
**Page 36**

Iron Body Swing Check Valve  
Bronze Trim  
500 PSI WWP



**F-968-B**  
Sizes 2 1/2" thru 6"  
Class 250 Flanged Ends  
**Page 37**

# 285 PSI WWP Ductile Iron Body Gate Valves

Fire Protection Valve • Raised Face Flanges Class 150 • Bolted Bonnet •  
Outside Screw and Yoke • Solid Wedge • B584 Bronze Trim

**285 PSI/19.7 Bar Non-Shock Cold Working Pressure**  
**to -20° F to 100° F/-29° C to 38° C**

TESTING SPECIFICATION TO MSS SP-70



**F-637-31**  
Flanged-Raised Face

## MATERIAL LIST

PART	SPECIFICATION
1. Stem	Bronze ASTM B371
2. Handwheel Nut	Bronze ASTM B584
3. Identification Plate	Aluminum
4. Yoke Bushing	Bronze ASTM B584
5. Handwheel	Iron ASTM A126 Class B
6. Bonnet Cap Nut	Steel ASTM A307
7. Bonnet Cap	Ductile Iron ASTM A536
8. <sup>1</sup> Bonnet	Ductile Iron ASTM A395
9. Bonnet Cap Bolt	Steel ASTM A307
10. Gland Follower Nut	Brass ASTM B36
11. Gland Follower	Ductile Iron ASTM A536
12. Packing Gland	Brass or Iron
13. Packing	PTFE Braided
14. Gland Follower Bolt	Steel ASTM A307
15. Backseat Bushing	Bronze ASTM B584
16. Body Nut	Steel ASTM A307
17. Body Bolt	Steel ASTM A307
18. Wedge Pin	Bronze ASTM B371
19. Body	Ductile Iron ASTM A395
20. <sup>3</sup> Seat Ring	Bronze ASTM B584
21. Wedge Face Ring	Bronze ASTM B584
22. <sup>2</sup> Wedge	Ductile Iron ASTM A395
23. Body Gasket	Synthetic Fibres
24. Stem Collar	Bronze ASTM B371
25. Grease Fitting	Alemite 1743B (not shown)

<sup>1</sup> Sizes thru 8" made with Yoke Integral with Bonnet. 10" and 12" sizes made with separate Yoke Bolted to Bonnet.

<sup>2</sup> Sizes 2" thru 6" are all Bronze (31 Trim).  
Sizes 8" thru 12" Ductile Iron Wedge with Bronze Wedge Face Rings (31 Trim).

<sup>3</sup> Lugs may be removed at customer's request - POA.

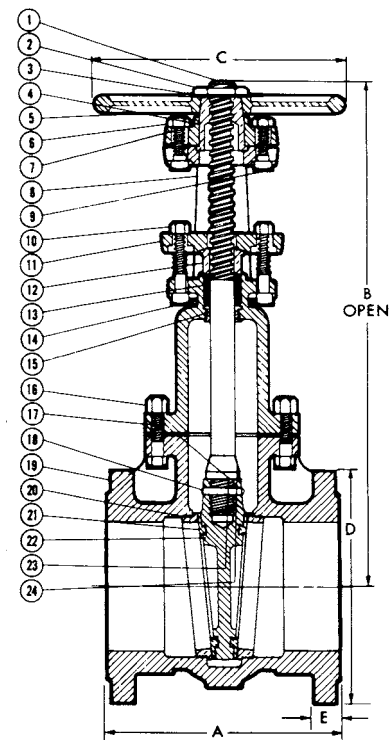

**F-637-31**  
Flg x Flg

## DIMENSIONS—WEIGHTS—QUANTITIES

Size	Dimensions										F-637-31 Weight		
	A		B		C		D		E		Lbs.	Kg.	
In.	mm.	In.	mm.	In.	mm.	In.	mm.	In.	mm.	In.	mm.		
2	50	7.00	178	16.31	414	8.00	203	6.00	152	.63	16	41	19
2½	65	7.50	191	17.19	437	8.00	203	7.00	178	.69	17	55	25
3	80	8.00	203	19.50	495	8.00	203	7.50	191	.75	19	67	30
4	100	9.00	229	24.00	610	10.00	254	9.00	229	.94	24	107	48
5	125	10.00	254	27.13	689	10.00	254	10.00	254	.94	24	145	66
6	150	10.50	267	31.06	789	12.00	305	11.00	279	1.00	25	178	81
8	200	11.50	292	40.19	1021	14.00	356	13.50	343	1.13	29	309	140
10	250	13.00	330	48.25	1226	16.00	406	16.00	406	1.19	30	481	218
12	300	14.00	356	56.88	1445	18.00	457	19.00	483	1.25	32	706	320

**FREEZING WEATHER PRECAUTION:** Subsequent to testing a piping system, valves should be left in an open position to allow complete drainage.



# 500 PSI WWP Iron Body Gate Valves

Fire Protection Valve • Bolted Bonnet • Outside Screw and Yoke •  
Solid Wedge • Bronze Mounted • Class 250 Flanges

**500 PSI/34.5 Bar Non-Shock Cold Working Pressure**  
**-20° F to 150° F/-29° C to 66° C**

CONFORMS TO MSS SP-70 • APPROVED BY THE NEW  
YORK CITY B.S.A. 143-69-SA AT 350 PSI NON-SHOCK  
COLD WATER

## MATERIAL LIST

PART	SPECIFICATION
1. Stem	Brass ASTM B16 Alloy C36000
2. Handwheel Nut	Cast Bronze ASTM B584 Alloy C84400
3. Identification Plate	Aluminum
4. Yoke Bushing	Cast Bronze ASTM B584 Alloy C84400
5. Handwheel	Cast Iron ASTM A126 Class B
6. Bonnet Cap Nut	Steel ASTM A307
7. Bonnet Cap	Cast Iron ASTM A126 Class B or Ductile Iron ASTM A536
8. <sup>1</sup> Bonnet	Cast Iron ASTM A126 Class B
9. Bonnet Cap Bolt	Steel ASTM A307
10. Gland Follower Nut	Brass ASTM F467 Alloy C27000
11. Gland Follower	Cast Iron ASTM A126 Class B or Ductile Iron ASTM A536
12. Packing Gland	Zinc Plated Powdered Iron ASTM B783 or Brass ASTM B16
13. Packing	PTFE Braided
14. Gland Follower Bolt	Steel ASTM A307
15. Backseat Bushing	Cast Bronze ASTM B584 Alloy C84400
16. Body Nut	Steel ASTM A307
17. Body Gasket	Reinforced Graphite
18. Body Bolt	Steel ASTM A307
19. Body	Cast Iron ASTM A126 Class B
20. Stem Collar	Brass ASTM B16 Alloy C36000
21. <sup>2</sup> Wedge	Cast Iron ASTM A126 Class B
22. <sup>3</sup> Wedge Nut	Cast Bronze ASTM B584 Alloy C84400
23. Wedge Pin	Silicon Bronze ASTM B371 Alloy C69400 or ASTM B140 Alloy C31400
24. Seat Ring	Cast Bronze ASTM B584 Alloy C84400
25. <sup>2</sup> Wedge Face Ring	Cast Bronze ASTM B584 Alloy C84400

<sup>1</sup>Sizes 2" thru 8" made with Yoke Integral with Bonnet. Sizes 8" thru 12" made with separate Yoke Bolted to Bonnet.

<sup>2</sup>Wedge construction - 2" thru 3" all bronze.  
- 4" thru 12" Cast Iron with Bronze Wedge Face Rings.

<sup>3</sup>Bronze Wedge Nuts used on sizes 5" thru 12".

## DIMENSIONS—WEIGHTS—QUANTITIES

Size	Dimensions										F-667-O Weight		
	A		B		C		D		E		Lbs.	Kg.	
In. mm.	In.	mm.	In.	mm.	In.	mm.	In.	mm.	In.	mm.			
2	50	8.50	216	16.00	406	8	203	6.50	165	.88	22	56	25
2½	65	9.50	241	18.44	468	8	203	7.50	191	1.00	25	74	34
3	80	11.13	283	20.50	521	10	254	8.25	210	1.13	29	122	55
4	100	12.00	305	27.00	686	12	305	10.00	254	1.25	32	193	87
5	125	15.00	381	31.50	800	12	305	11.00	279	1.38	35	297	135
6	150	15.88	403	33.00	838	16	406	12.50	318	1.44	37	411	187
8	200	16.50	419	45.50	1156	16	406	15.00	381	1.63	41	637	289
10	250	18.00	457	56.00	1422	20	508	17.50	445	1.88	48	897	407
12	300	19.75	502	60.00	1524	20	508	20.50	521	2.00	51	1172	532



**F-667-O**  
Flanged

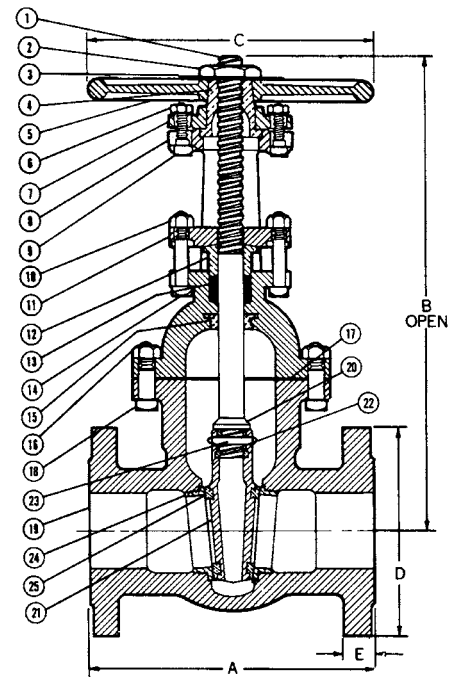

**F-667-O**  
Flg x Flg

**FREEZING WEATHER PRECAUTION:** Subsequent to testing a piping system, valves should be left in an open position to allow complete drainage.

# 300/350 PSI WWP Iron Body Gate Valves

Fire Protection Valve • Bolted Bonnet • Outside Screw and Yoke • Solid Wedge • Class 250 Flanges

## 300/350 PSI/20.7/24 Bar Non-Shock Cold Water

CONFORMS TO MSS SP-70 • UL LISTED 350 PSI • FM APPROVED 300 PSI  
• APPROVED BY NEW YORK CITY M.E.A. 420-92-E VOL. 2 AT 350 PSI  
NON-SHOCK COLD WATER

### MATERIAL LIST

PART	SPECIFICATION
1. Stem	Brass ASTM B16 Alloy C36000
2. Handwheel Nut	Cast Bronze ASTM B584 Alloy C84400
3. Identification Plate	Aluminum
4. Yoke Bushing	Cast Bronze ASTM B584 Alloy C84400
5. Handwheel	Cast Iron ASTM A126 Class B
6. Bonnet Cap Nut	Steel ASTM A307
<sup>1</sup> 7. Bonnet Cap	Ductile Iron ASTM A536
<sup>1</sup> 8. Bonnet	Cast Iron ASTM A126 Class B
9. Bonnet Cap Bolt	Steel ASTM A307
10. Gland Follower Nut	Brass ASTM B36
11. Gland Follower	Ductile Iron ASTM A536
12. Packing Gland	Zinc Plated Powdered Iron ASTM B310 or Brass ASTM B16
13. Packing	Non Asbestos
14. Gland Follower Bolt	Steel ASTM A307
15. Backseat Bushing	Cast Bronze ASTM B584 Alloy C84400
16. Body Nut	Steel ASTM A307
17. Body Gasket	Non Asbestos
18. Body Bolt	Steel ASTM A307
19. Body	Cast Iron ASTM A126 Class B
20. Stem Collar	Cast Bronze ASTM B584 Alloy C84400
<sup>2</sup> 21. Wedge	Cast Iron ASTM A126 Class B
<sup>3</sup> 22. Wedge Nut	Cast Bronze ASTM B584 Alloy C84400
23. Wedge Pin	Silicon Bronze B140 Alloy C31600
24. Seat Ring	Cast Bronze ASTM B584 Alloy C84400
<sup>2</sup> 25. Wedge Face Ring	Cast Bronze ASTM B584 Alloy C84400

<sup>1</sup> Sizes 2½" thru 6" made as shown using bonnet cap.  
8" thru 10" made with separate yoke bolted to bonnet.

<sup>2</sup> Wedge construction - 2½" thru 3" all bronze.  
4" thru 10" cast iron with bronze wedge face rings.

<sup>3</sup> Bronze wedge nuts used on sizes 6" thru 10".

NOTE: Tamper switch requires field modification of stem.

### DIMENSIONS—WEIGHTS—QUANTITIES

Size	Dimensions										Weight		
	A		B		C		D		E		Lbs.	Kg.	
In. mm.	In.	mm.	In.	mm.	In.	mm.	In.	mm.	In.	mm.			
2½	65	9.5	241	18.44	468	8.00	203	7.50	191	1.00	25	74	34
3	80	11.13	283	20.50	521	10.00	254	8.25	210	1.13	29	122	55
4	100	12.00	305	27.00	686	12.00	305	10.00	254	1.25	32	193	88
6	150	15.88	403	33.00	838	16.00	406	12.50	318	1.44	37	411	186
8	200	16.50	419	45.50	1156	16.00	406	15.00	381	1.63	41	637	290
10	250	18.00	457	56.00	1422	20.00	508	17.50	445	1.88	48	897	408



**F-697-0**  
Flanged

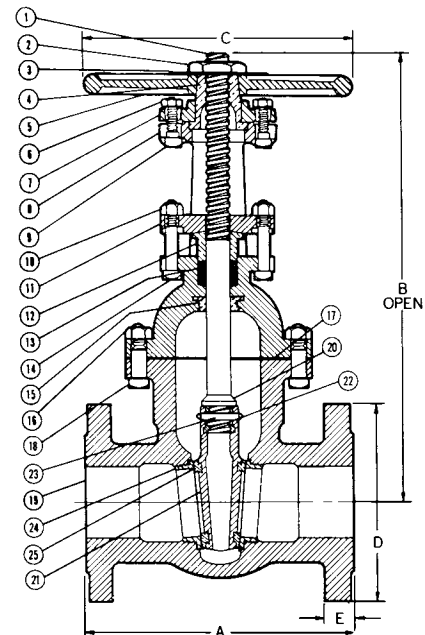

**F-697-0**  
Flg x Flg



**FREEZING WEATHER PRECAUTION:** Subsequent to testing a piping system, gate valves should be left in an open position to allow complete drainage.

# 285 PSI WWP Ductile Iron Body Swing Check Valves

Fire Protection Valve • Class 150 • Raised Face Flanges • Bolted Bonnet • B584 Bronze Trim

**285 PSI/19.7 Bar Non-Shock Cold Working Pressure**  
**-20° F to 100° F/-29° C to 38° C**

TESTING SPECIFICATION TO MSS SP-71



**F-938-31**  
Flanged-Raised Face

## MATERIAL LIST

PART	SPECIFICATION
1. Bolt	Steel ASTM A307
2. Identification Plate	Aluminum
3. Bonnet	Ductile Iron ASTM A395
4. Body Gasket	Synthetic Fibres
5. Nut	Steel ASTM A307
6. Side Plug	Bronze ASTM B584
7. Hanger Pin	Bronze ASTM B371
8. Hanger	Bronze ASTM B584 or Ductile Iron ASTM A536
*9. Disc	Bronze ASTM B584
10. Seat Ring	Bronze ASTM B584
11. Disc Nut	Bronze ASTM B371
12. Body	Ductile Iron ASTM A395

## DIMENSIONS—WEIGHTS—QUANTITIES

Size	Dimensions										F-938-31 Weight	
	A		B		D		E		Lbs.	Kg.		
In.	mm.	In.	mm.	In.	mm.	In.	mm.	In.	mm.			
2	50	8.00	203	3.94	100	6.00	152	.63	16	24	11	
2½	65	8.50	216	4.50	114	7.00	178	.69	17	35	16	
3	80	9.50	241	5.13	130	7.50	191	.75	19	47	21	
4	100	11.50	292	6.13	156	9.00	229	.94	24	81	37	
5	125	13.00	330	6.81	173	10.00	254	.94	24	100	45	
6	150	14.00	356	8.00	203	11.00	279	1.00	25	146	66	
8	200	19.50	495	9.44	240	13.50	343	1.13	29	255	116	
10	250	24.50	622	12.06	306	16.00	406	1.19	30	426	193	
12	300	27.50	699	16.13	410	19.00	483	1.25	32	660	299	

Lever and Weight/Spring Options available.

\*2"-4" have bronze disc; 5"-12" have ductile iron disc with bronze seat ring

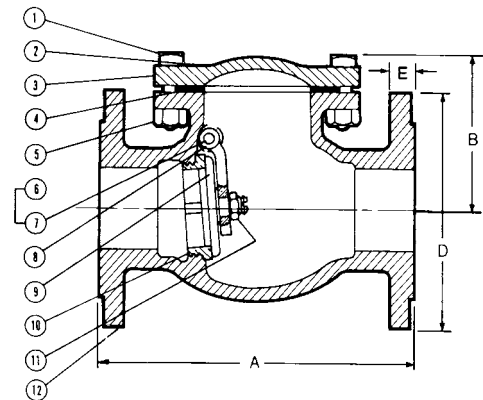

**F-938-31**  
Flg x Flg

NIBCO Check Valves may be installed in both horizontal and vertical lines with upward flow or in any intermediate position.

**WARNING: Do not use for Reciprocating Air Compressor Service.**

# 500 PSI WWP Iron Body Check Valves

Fire Protection Valve • Bolted Bonnet • Horizontal Swing • \*Renewable Bronze Seat and Disc • Class 250 Flanges

**500 PSI/34.5 Bar Non-Shock Cold Working Pressure**  
**-20° F to 150° F/-29° C to 66° C**

CONFORMS TO MSS SP-71 TYPE 1 • APPROVED BY  
NEW YORK CITY B.S.A. 143-69-SA AT 350 PSI  
NON-SHOCK COLD WATER



**F-968-B**  
Flanged

## MATERIAL LIST

PART	SPECIFICATION
1. Body Bolt	Steel ASTM A307
2. Identification Plate	Aluminum
3. Bonnet	Cast Iron ASTM A126 Class B
4. Body Gasket	Reinforced Graphite
5. Body Nut	Steel ASTM A307
6. Side Plug	Brass ASTM B16 Alloy C36000
7. Hanger Pin	Brass ASTM B16 Alloy C36000
8. Hanger	Cast Bronze ASTM B584 Alloy C84400
9. Disc Nut	Cast Bronze ASTM B584 Alloy C84400
10. Disc	Cast Bronze ASTM B584 Alloy C84400
11. Seat Ring	Cast Bronze ASTM B584 Alloy C84400
12. Body	Cast Iron ASTM A126 Class B

## DIMENSIONS—WEIGHTS—QUANTITIES

Size	Dimensions								F-968-B Weight		
	A		B		D		E		Lbs.	Kg.	
In.	mm.	In.	mm.	In.	mm.	In.	mm.	In.	mm.		
2½	65	11.50	292	5.83	149	7.50	191	1.00	25	62	28
3	80	12.50	318	6.31	160	8.25	210	1.13	29	77	35
4	100	14.00	356	7.56	192	10.00	254	1.25	32	129	58
6	150	17.50	445	8.50	216	12.50	318	1.44	37	225	102

\* Proper machining facilities required.

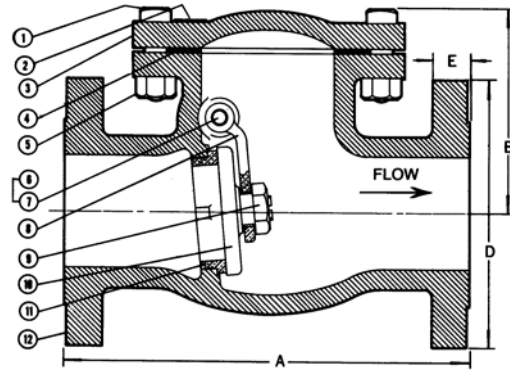









**F-968-B**  
Flg x Flg

**WARNING: Do not use for Reciprocating Air Compressor Service.**

NIBCO Iron Body Check Valves may be installed in both horizontal and vertical lines with upward flow or in any intermediate position.

# Iron UL/FM Butterfly Valves

## Illustrated Index

<p>UL Listed • FM Approved Ductile Iron Butterfly Valve Gear Operator with Flag 250 PSI WWP</p>  <p><b>WD-3510-4/8</b> Wafer Style Body Sizes 2" thru 12" <b>Page 39</b></p>	<p>UL Listed • FM Approved Ductile Iron Butterfly Valve Gear Operator with Flag 250 PSI WWP</p>  <p><b>LD-3510-4/8</b> Lug Style Body Sizes 2" thru 12" <b>Page 40</b></p>	<p>UL Listed • FM Approved • Designed for normally closed position monitoring Ductile Iron Butterfly Valve Gear Operator with Flag 250 PSI WWP</p>  <p><b>WD-3510-C-8</b> Wafer Style Body Sizes 2½" thru 8" <b>Page 40</b></p>	<p>UL Listed • FM Approved • Designed for normally closed position monitoring Ductile Iron Butterfly Valve Gear Operator with Flag 250 PSI WWP</p>  <p><b>LD-3510-C-8</b> Lug Style Body Sizes 2½" thru 8" <b>Page 40</b></p>
<p>UL Listed • FM Approved Nylon Coated Ductile Iron Body Gear Operator with Flag 300 PSI WWP</p>  <p><b>GD-1765-8N</b> <b>GD-4865-8N</b> Grooved Mechanical Style Sizes 2½" thru 10" <b>Page 40</b></p>	<p>UL Listed • FM Approved • Designed for normally closed position monitoring Nylon Coated Ductile Iron Body Gear Operator with Flag 300 PSI WWP</p>  <p><b>GD-4865-C-8N</b> Grooved Mechanical Style Sizes 2½" thru 10" <b>Page 41</b></p>	<p>UL Listed Nylon Coated Ductile Iron Body Gear Operator with Flag 350 PSI WWP</p>  <p><b>GD-6865-8N</b> Grooved Mechanical Style Sizes 2½" thru 10" <b>Page 42</b></p>	<p>UL Listed • FM Approved • Designed for normally closed position monitoring Nylon Coated Ductile Iron Body Gear Operator with Flag 350 PSI WWP</p>  <p><b>GD-6865-C-8N</b> Grooved Mechanical Style Sizes 2½" thru 10" <b>Page 43</b></p>

# 250 PSI WWP UL/FM Butterfly Valves

Fire Protection Valve • Wafer or Lug Style Body • Molded in Seat •  
Accepts Internal Supervisory Switches • Mates with C.I. Class 125/Steel Class 150 Flanges

## 250 PSI/17.2 Bar Non-Shock Cold Water

DESIGNED TO COMPLY WITH MSS SP-67 • UL/ULC LISTED • FM APPROVED •  
2" - 12" UL/FM LISTED FOR INDOOR AND OUTDOOR SERVICE • APPROVED BY  
NEW YORK CITY MEA 90-07-E • CALIFORNIA STATE FIRE MARSHAL  
LISTING NO. 7770-1243:104 • U.S. COAST GUARD "Category A"



**WD3510-8\*\***

Wafer  
(4" Shown)

**LD3510-8\*\***

Lug  
(Not Shown)

### MATERIAL LIST

PART	SPECIFICATION
1. Stem	Stainless Steel ASTM 582 Type 416
2. Collar Bushing	Brass ASTM B124
3. Upper Bushing	Copper Alloy CDA 122
4. Stem Seal	EPDM
5. Body Seal	EPDM
6. Disc	Ductile Iron ASTM 395 (Nickel Plated)
7. Liner	EPDM
8. Lower Bushing	Copper Alloy CDA 122
9. Nameplate	Aluminum
10. Body	Ductile Iron ASTM A536
11. Gear Operator	Cast Iron and Steel
12. Indicator Flag	Cast Iron
13. Handwheel	Cast Iron

\*\*8 version has two factory mounted internal supervisory switches.  
-4 version has no switches.

Note: Wafer body will mate with ANSI or ISO flanges. O.D. of wafer body notched to fit ISO bolt circle.  
For dead-end service use lug style (rated 200 PSI for this service).

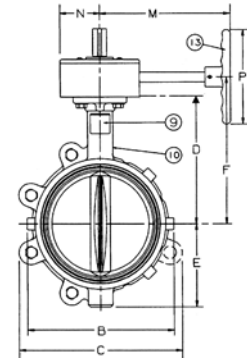

### DIMENSIONS—WEIGHTS—QUANTITIES

Size	Dimensions																				
	A	B	C	D	E	F	G	H	I	J											
2	50	2.53	64	4.88	124	4.62	117	5.38	137	2.88	73	6.89	175	12.75	324	1.68	43	1.81	46	2.91	74
2½	65	2.90	74	5.62	143	5.12	130	5.88	149	3.25	83	7.36	187	13.63	346	1.81	46	1.94	49	2.91	74
3	80	3.17	81	6.12	155	5.50	140	6.12	155	3.38	86	7.60	193	14.00	356	1.81	46	1.94	49	2.91	74
4	100	4.17	106	7.00	178	6.25	160	6.88	175	4.00	102	8.39	213	15.38	391	2.06	52	2.19	56	2.91	74
5	125	5.17	131	8.25	210	9.38	238	7.38	187	4.75	121	8.86	225	16.63	422	2.19	56	2.31	59	2.91	74
6	150	6.17	157	9.25	235	10.25	260	8.00	203	5.25	133	9.49	241	17.75	451	2.19	56	2.31	59	2.91	74
8	200	8.17	208	11.62	295	12.38	314	9.25	235	6.50	165	10.75	273	20.25	514	2.38	60	2.50	64	2.91	74
10	250	10.17	258	14.25	362	15.50	394	10.50	267	8.00	203	12.28	312	23.50	597	2.68	69	2.81	71	3.90	99
12	300	12.17	309	16.75	425	18.25	464	12.00	305	9.25	235	13.78	350	26.25	667	3.00	76	3.12	79	3.90	99

Size	Dimensions				Flange/Stud Data				Weight													
	K	M	N	P	Dia	Wafer	Lug	BC	Lug	Wafer												
2	50	3.54	90	5.82	148	2.13	54	5.9	150	4	5/8	16	4.00	101	1.25	32	4.75	121	23	11	21	10
2½	65	3.54	90	5.82	148	2.13	54	5.9	150	4	5/8	16	4.25	108	1.50	38	5.50	140	25	11	24	11
3	80	3.54	90	5.82	148	2.13	54	5.9	150	4	5/8	16	4.25	108	1.50	38	6.00	152	26	12	24	11
4	100	3.54	90	5.82	148	2.13	54	5.9	150	8	5/8	16	5.00	127	2.00	51	7.50	191	31	14	27	12
5	125	3.54	90	7.64	194	2.13	54	5.9	150	8	3/4	20	5.25	133	2.00	51	8.50	216	37	17	31	14
6	150	3.54	90	7.64	194	2.13	54	5.9	150	8	3/4	20	5.25	133	2.00	51	9.50	241	40	18	34	15
8	200	3.54	90	7.91	201	2.13	54	9.8	250	8	3/4	20	5.75	146	2.25	57	11.75	298	55	25	49	22
10	250	3.98	101	9.49	241	3.03	77	18.0	457	12	7/8	22	6.25	159	2.50	64	14.25	362	95	43	78	35
12	300	3.98	101	9.49	241	3.03	77	18.0	457	12	7/8	22	6.75	171	2.50	64	17.00	432	123	56	103	47

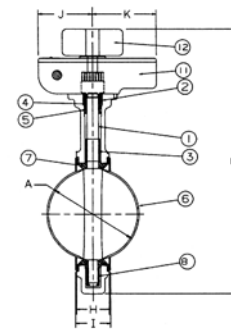

(10" Shown)



# 250 PSI WWP UL/FM Butterfly Valves

Designed for normally closed position monitoring

Fire Protection Valve • Lug or Wafer Style Body • Factory Mounted Monitoring Switches • Mates with C.I. Class 125 and Steel Class 150 Flanges

## 250 PSI/17.2 Bar Non-Shock Cold Water

UL/ULC LISTED\*\* • FM APPROVED\*\* • DESIGNED TO COMPLY WITH MSS SP-67  
2½" - 8" UL/FM LISTED FOR INDOOR AND OUTDOOR SERVICE

**Warning: These valves are not to be used between the water source and sprinkler head.**

### MATERIAL LIST

PART	SPECIFICATION
1. Stem	Stainless Steel ASTM 582 Type 416
2. Collar Bushing	Brass ASTM B124
3. Upper Bushing	Copper Alloy CDA 122
4. Stem Seal	EPDM
5. Body Seal	EPDM
6. Disc	Ductile Iron ASTM 395 (Nickel Plated)
7. Liner	EPDM
8. Lower Bushing	Copper Alloy CDA 122
9. Nameplate	Aluminum
10. Body	Ductile Iron ASTM A536
11. Gear Operator	Cast Iron and Steel
12. Indicator Flag	Cast Iron
13. Handwheel	Cast Iron



LD-3510-C-8

WD-3510-C-8

Note: Wafer body will mate with ANSI or ISO flanges. O.D. of wafer body notched to fit ISO bolt circle.

For dead-end service use lug style (rated 200 PSI for this service).

Comes with two factory mounted internal supervisory switches. Use switch Figure No. TS-4. See page 4 of I & M manual for installation & wiring instructions

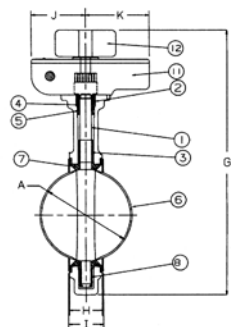
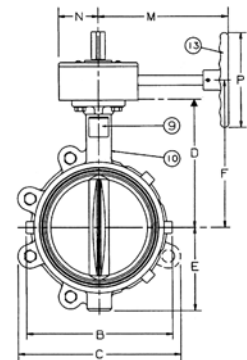

### DIMENSIONS—WEIGHTS—QUANTITIES

Size	Dimensions																				
	A	B	C	D	E	F	G	H	I	J											
2½	65	2.90	74	5.62	143	5.12	130	5.88	149	3.25	83	7.36	187	13.63	346	1.81	46	1.94	49	2.91	74
3	80	3.17	81	6.12	155	5.50	140	6.12	155	3.38	86	7.60	193	14.00	356	1.81	46	1.94	49	2.91	74
4	100	4.17	106	7.00	178	8.25	210	6.88	175	4.00	102	8.39	213	15.38	391	2.06	52	2.19	56	2.91	74
6	150	6.17	157	9.25	235	10.25	260	8.00	203	5.25	133	9.49	241	17.75	451	2.19	56	2.31	59	2.91	74
8	200	8.17	208	11.62	295	12.38	314	9.25	235	6.50	165	10.75	273	20.25	514	2.38	60	2.50	64	2.91	74

Size	Dimensions				Flange/Stud Data				Weight													
	K	M	N	P	Dia	Wafer	Lug	BC	Lug	Wafer												
2½	65	3.54	90	5.82	148	2.13	54	5.9	150	4	¾	16	4.25	108	1.50	38	5.50	140	25	11	24	11
3	80	3.54	90	5.82	148	2.13	54	5.9	150	4	¾	16	4.25	108	1.50	38	6.00	152	26	12	24	11
4	100	3.54	90	5.82	148	2.13	54	5.9	150	8	¾	16	5.00	127	2.00	51	7.50	191	31	14	27	12
6	150	3.54	90	7.64	194	2.13	54	5.9	150	8	¾	20	5.25	133	2.00	51	9.50	241	40	18	34	15
8	200	3.54	90	7.91	201	2.13	54	9.8	250	8	¾	20	5.75	146	2.25	57	11.75	298	55	25	49	22

\*\*Compliance with standards for butterfly valves for fire protection UL1091 & FM1112



# 300 PSI WWP UL/FM Butterfly Valves

Designed for normally open position monitoring

Fire Protection Valve • Grooved Mechanical Style • Nylon Coated Ductile Iron Body • Extended Neck • Elastomer Encapsulated Disc • Accepts Internal Supervisory Switches • Compatible with IPS Pipe†

## 300 PSI/20.7 Bar Non-Shock Cold Water

UL/ULC LISTED\*\* • UL/FM LISTED FOR INDOOR AND OUTDOOR SERVICE • THIRD PARTY CERTIFIED TO NSF/ANSI 61 AND 372

### GD-1765-4N

10"  
(not shown)  
175 PSI



### GD-4865-4N

(not shown)  
No Switches

### GD-4865-8N

Grooved  
2½", 3", 4", 6", 8", 10"

### MATERIAL LIST

PART	SPECIFICATION
1 Indicator Flag	Painted Steel
2 Stem Adapter	Steel
3 Gear Operator	Cast Iron and Steel
4 Retaining Ring	Carbon Steel
5 Cartridge Seal	Brass ASTM C36000
6 Stem Seals	EPDM
7 Upper Stem	Stainless Steel ASTM A582 Type 416
8 Upper Bushing	Plated Steel with PTFE Lining
9 Body	Ductile Iron ASTM A395 with Polyamide Coating
10 Disc	Ductile Iron ASTM A536 with EPDM Encapsulation
11 Lower Bushing	Steel with PTFE Lining
12 Lower Stem	Stainless Steel ASTM A582 Type 416
13 Handwheel	Cast Iron

Factory mounted with two internal supervisory switches.  
Uses NIBCO model T1446762 PP switch.  
Ground post (-GP) and wall post (-WP) available.  
Normally open monitored only.

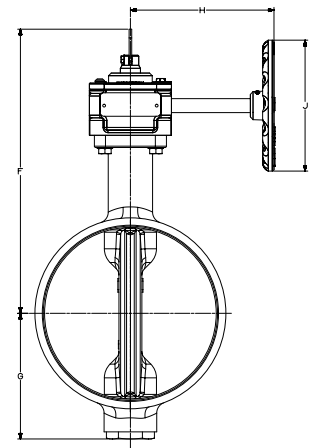
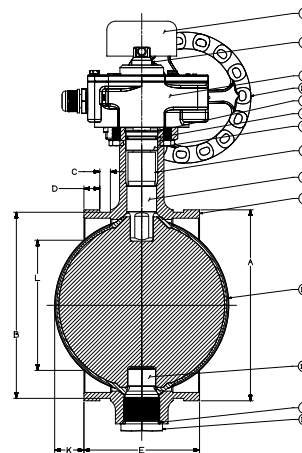

### DIMENSIONS—WEIGHTS

SIZE	Dimensions														Weight										
	A	B	C	D	E	F	G	H	J	K	L	Lbs.	Kg.												
2½"	65	2.88	73	2.72	69	0.31	8	0.63	16	3.81	97	8.95	227	2.20	56	4.92	125	4.25	108	—	—	—	—	9.5	4.3
3 OD	76.1	3.00	76.1	2.85	72	0.31	8	0.63	16	3.81	97	9.16	233	2.47	63	4.92	125	4.25	108	—	—	—	—	11.3	5.2
3	80	3.50	80.0	3.34	85	0.31	8	0.63	16	3.81	97	9.16	233	2.47	63	4.92	125	4.25	108	—	—	—	—	11.6	5.3
4	100	4.50	114.3	4.33	110	0.38	10	0.63	16	4.56	116	10.00	254	3.00	76	4.92	125	4.25	108	—	—	—	—	15.0	6.8
6 OD	165.1	6.50	165.1	6.33	161	0.38	10	0.63	16	5.81	148	11.92	303	4.33	110	6.48	165	6	152	—	—	—	—	31.5	14.3
6	150	6.63	168.3	6.45	164	0.38	10	0.63	16	5.81	148	11.92	303	4.33	110	6.48	165	6	152	—	—	—	—	31.3	14.2
8	200	8.63	219	8.44	214	0.44	11	0.75	19	5.25	133	12.85	326	5.67	114	6.48	165	6	152	1.32	34	5.87	149	43.0	19.5
10	250	10.77	250	10.55	268	0.50	13	0.75	19	6.25	159	15	381	6.77	172	8.74	222	6	152	1.74	44	7.44	189	77.0	35

\*\* Compliance with the Standard for Butterfly Valves for Fire Protection Service, UL 1091, and Indicating Valves, FM Class Number 1112.

† See Grooved Pipe Specification section





# 300 PSI WWP UL/FM Butterfly Valves

Designed for normally closed position monitoring

Fire Protection Valve • Grooved Mechanical Style • Nylon Coated Ductile Iron Body • Extended Neck • Elastomer Encapsulated Disc • Factory Installed Internal Monitoring Switches • Compatible with IPS Pipe†

## 300 PSI/20.7 Bar Non-Shock Cold Water 2½" - 10"

UL/ULC LISTED\*\* • 2½" - 10" LISTED FOR INDOOR AND OUTDOOR SERVICE • THIRD PARTY CERTIFIED TO NSF/ANSI 61 AND 372

**Warning:** These valves are **not** to be used between the water source and sprinkler head.

### MATERIAL LIST

PART	SPECIFICATION
1 Indicator Flag	Painted Steel
2 Stem Adapter	Steel
3 Gear Operator	Cast Iron and Steel
4 Retaining Ring	Carbon Steel
5 Cartridge Seal	Brass ASTM C36000
6 Stem Seals	EPDM
7 Upper Stem	Stainless Steel ASTM A582 Type 416
8 Upper Bushing	Plated Steel with PTFE Lining
9 Body	Ductile Iron ASTM A395 with Polyamide Coating
10 Disc	Ductile Iron ASTM A536 with EPDM Encapsulation
11 Lower Bushing	Steel with PTFE Lining
12 Lower Stem	Stainless Steel ASTM A582 Type 416
13 Handwheel	Cast Iron

**Note:** Comes with two factory mounted internal supervisory switches. Uses NIBCO model T1447532 PP switch. See of I & M manual for installation and wiring instructions.

Ground post or wall post not available.  
Normally closed monitored.



### GD-4865-C-8N

2½", 3", 4", 6", 8", 10"

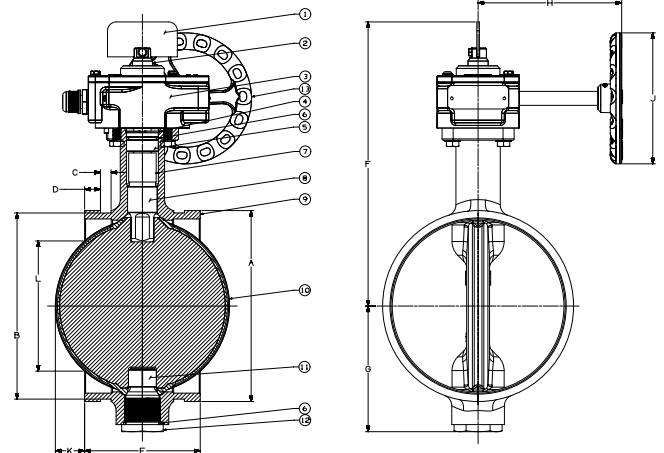

### DIMENSIONS—WEIGHTS

SIZE	Dimensions												Weight												
	A		B		C		D		E		F		G		H		J		K		L		Lbs.	Kg.	
In.	mm.	In.	mm.	In.	mm.	In.	mm.	In.	mm.	In.	mm.	In.	mm.	In.	mm.	In.	mm.	In.	mm.	In.	mm.				
2½"	65	2.88	73	2.72	69	0.31	8	0.63	16	3.81	97	8.95	227	2.20	56	4.92	125	4.25	108	—	—	—	—	9.5	4.3
3 OD	76.1	3.00	76.1	2.85	72	0.31	8	0.63	16	3.81	97	9.16	233	2.47	63	4.92	125	4.25	108	—	—	—	—	11.3	5.2
3	80	3.50	80.0	3.34	85	0.31	8	0.63	16	3.81	97	9.16	233	2.47	63	4.92	125	4.25	108	—	—	—	—	11.6	5.3
4	100	4.50	114.3	4.33	110	0.38	10	0.63	16	4.56	116	10.00	254	3.00	76	4.92	125	4.25	108	—	—	—	—	15.0	6.8
6 OD	165.1	6.50	165.1	6.33	161	0.38	10	0.63	16	5.81	148	11.92	303	4.33	110	6.48	165	6	152	—	—	—	—	31.5	14.3
6	150	6.63	168.3	6.45	164	0.38	10	0.63	16	5.81	148	11.92	303	4.33	110	6.48	165	6	152	—	—	—	—	31.3	14.2
8	200	8.63	219	8.44	214	0.44	11	0.75	19	5.25	133	12.85	326	5.67	114	6.48	165	6	152	1.32	34	5.87	149	43.0	19.5
10	250	10.77	250	10.55	268	0.50	13	0.75	19	6.25	159	15	381	6.77	172	8.74	222	6	152	1.74	44	7.44	189	77.0	35

\*\* Compliance with the Standard for Butterfly Valves for Fire Protection Service, UL 1091 and Indicating Valves, FM Class Number 1112.

† See Grooved Pipe Specification section



# 350 PSI WWP UL/FM Butterfly Valves

Designed for normally open position monitoring

Fire Protection Valve • Grooved Mechanical Style • Nylon Coated Ductile Iron Body • Extended Neck • Elastomer Encapsulated Disc • Internal Supervisory Switches • Compatible with IPS Pipe†

**350 PSI/24 Bar Non-Shock Cold Water 2½" - 10"**

UL/ULC LISTED\*\* • UL/FM LISTED FOR INDOOR AND OUTDOOR SERVICE • THIRD PARTY CERTIFIED TO NSF/ANSI 61 AND 372



**GD-6865-4N**  
(not shown)  
No Switches

**GD-6865-8N**  
Grooved  
2½", 3", 4", 6", 8", 10"

## MATERIAL LIST

PART	SPECIFICATION
1 Indicator Flag	Painted Steel
2 Stem Adapter	Steel
3 Gear Operator	Cast Iron and Steel
4 Retaining Ring	Carbon Steel
5 Cartridge Seal	Brass ASTM C36000
6 Stem Seals	EPDM
7 Upper Stem	Stainless Steel ASTM A582 Type 416
8 Upper Bushing	Steel with PTFE Lining
9 Body	Ductile Iron ASTM A395 with Polyamide Coating
10 Disc	Ductile Iron ASTM A536 with EPDM Encapsulation
11 Lower Bushing	Steel with PTFE Lining
12 Lower Stem	Stainless Steel ASTM A582 Type 416
13 Handwheel	Cast Iron

Factory mounted with two internal supervisory switches.  
Uses NIBCO model T1446762 PP switch.  
Ground post (-GP) and wall post (-WP) available. Normally open monitored only.

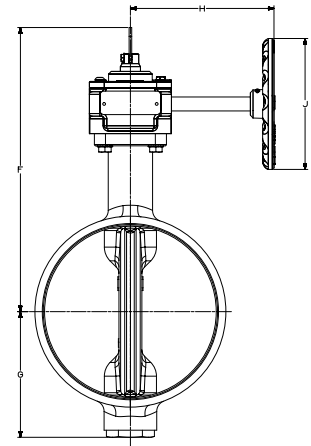
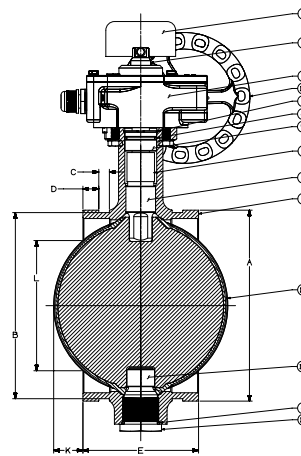

## DIMENSIONS—WEIGHTS

SIZE	Dimensions												Weight			
	A	B	C	D	E	F	G	H	J	K	L					
In. mm.	In. mm.	In. mm.	In. mm.	In. mm.	In. mm.	In. mm.	In. mm.	In. mm.	In. mm.	In. mm.	In. mm.	In. mm.	Lbs.	Kg.		
2½"	65 2.88	73 2.72	69 0.31	8 0.63	16 3.81	97 8.95	227 2.20	56 4.92	125 4.25	108	—	—	9.5	4.3		
3 OD	76.1 3.00	76.1 2.85	72 0.31	8 0.63	16 3.81	97 9.16	233 2.47	63 4.92	125 4.25	108	—	—	11.3	5.2		
3	80 3.50	80.0 3.34	85 0.31	8 0.63	16 3.81	97 9.16	233 2.47	63 4.92	125 4.25	108	—	—	11.6	5.3		
4	100 4.50	114.3 4.33	110 0.38	10 0.63	16 4.56	116 10.00	254 3.00	76 4.92	125 4.25	108	—	—	15.0	6.8		
6 OD	165.1 6.50	165.1 6.33	161 0.38	10 0.63	16 5.81	148 11.92	303 4.33	110 6.48	165 6	152	—	—	31.5	14.3		
6	150 6.63	168.3 6.45	164 0.38	10 0.63	16 5.81	148 11.92	303 4.33	110 6.48	165 6	152	—	—	31.3	14.2		
8	200 8.63	219 8.44	214 0.44	11 0.75	19 5.25	133 12.85	326 5.67	114 6.48	165 6	152	1.32	34	5.87	149	43.0	19.5
10	250 10.77	250 10.55	268 0.50	13 0.75	19 6.25	159 15	381 6.77	172 8.74	222 6	152	1.74	44	7.44	189	77.0	35

\*\* Compliance with the Standard for Butterfly Valves for Fire Protection Service, UL 1091, and Indicating Values, FM Class Number 1112.

† See Grooved Pipe Specification section



# 350 PSI WWP UL/FM Butterfly Valves

Designed for normally closed position monitoring

Fire Protection Valve • Grooved Mechanical Style • Nylon Coated Ductile Iron Body • Extended Neck • Elastomer Encapsulated Disc • Factory Installed Internal Monitoring Switches • Compatible with IPS Pipe

## 350 PSI/24 Bar Non-Shock Cold Water 2½" - 10"

UL/ULC LISTED\*\* • 2½" - 10" LISTED FOR INDOOR AND OUTDOOR SERVICE • THIRD PARTY CERTIFIED TO NSF/ANSI 61 AND 372

**Warning: These valves are not to be used between the water source and sprinkler head.**

### MATERIAL LIST

PART	SPECIFICATION
1 Indicator Flag	Painted Steel
2 Stem Adapter	Steel
3 Gear Operator	Cast Iron and Steel
4 Retaining Ring	Carbon Steel
5 Cartridge Seal	Brass ASTM C36000
6 Stem Seals	EPDM
7 Upper Stem	Stainless Steel ASTM A582 Type 416
8 Upper Bushing	Steel with PTFE Lining
9 Body	Ductile Iron ASTM A395 with Polyamide Coating
10 Disc	Ductile Iron ASTM A536 with EPDM Encapsulation
11 Lower Bushing	Steel with PTFE Lining
12 Lower Stem	Stainless Steel ASTM A582 Type 416
13 Handwheel	Cast Iron

**Note:** Comes with two factory mounted internal supervisory switches. Uses NIBCO model T1447532 PP switch. See I & M manual for installation and wiring instructions.

Ground post or wall post not available. Normally closed monitored.



**GD-6865-C-8N**

2½", 3", 4", 6", 8", 10"

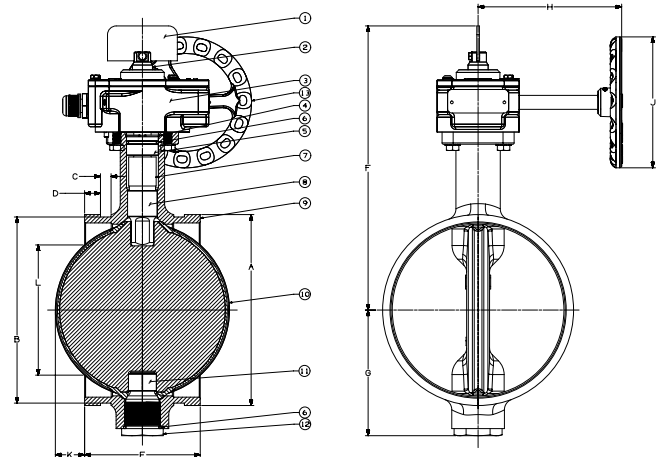

### DIMENSIONS—WEIGHTS

SIZE	Dimensions																		Weight						
	A		B		C		D		E		F		G		H		J		K		L		Lbs.	Kg.	
In.	mm.	In.	mm.	In.	mm.	In.	mm.	In.	mm.	In.	mm.	In.	mm.	In.	mm.	In.	mm.	In.	mm.	In.	mm.				
2½"	65	2.88	73	2.72	69	0.31	8	0.63	16	3.81	97	8.95	227	2.20	56	4.92	125	4.25	108	—	—	—	—	9.5	4.3
3 OD	76.1	3.00	76.1	2.85	72	0.31	8	0.63	16	3.81	97	9.16	233	2.47	63	4.92	125	4.25	108	—	—	—	—	11.3	5.2
3	80	3.50	80.0	3.34	85	0.31	8	0.63	16	3.81	97	9.16	233	2.47	63	4.92	125	4.25	108	—	—	—	—	11.6	5.3
4	100	4.50	114.3	4.33	110	0.38	10	0.63	16	4.56	116	10.00	254	3.00	76	4.92	125	4.25	108	—	—	—	—	15.0	6.8
6 OD	165.1	6.50	165.1	6.33	161	0.38	10	0.63	16	5.81	148	11.92	303	4.33	110	6.48	165	6	152	—	—	—	—	31.5	14.3
6	150	6.63	168.3	6.45	164	0.38	10	0.63	16	5.81	148	11.92	303	4.33	110	6.48	165	6	152	—	—	—	—	31.3	14.2
8	200	8.63	219	8.44	214	0.44	11	0.75	19	5.25	133	12.85	326	5.67	114	6.48	165	6	152	1.32	34	5.87	149	43.0	19.5
10	250	10.77	250	10.55	268	0.50	13	0.75	19	6.25	159	15	381	6.77	172	8.74	222	6	152	1.74	44	7.44	189	77.0	35

\*\* Compliance with the Standard for Butterfly Valves for Fire Protection Service, UL 1091, and Indicating Valves, FM Class Number 1112.

† See Grooved Pipe Specification section



# Butterfly Valves Indicator Post Assemblies

Available as Wall Post (WP\*) or Underground (GP\*\*)

Available with Internal Supervisory Switch 2" - 8" (UL Listed Indoor/Outdoor) - (8N Version)

Available with Grooved, Wafer or Lug Style Valves (UL Listed, Not FM Approved)

See Tech Bulletin on nibco.com for proper post sizing

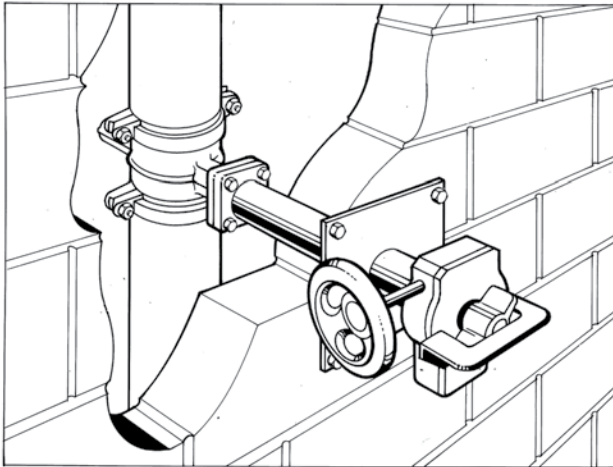

## GD-4765-8WP

Grooved Butterfly  
Wall Post Assembly  
(22" standard length)

## Mounting Hole Size

2" - 8" — 5½" hole diameter  
10" - 12" — 7½" hole diameter

## LD-3510-4GP

Lug/Wafer Butterfly  
Underground Post Assembly \*\*  
(66" standard length)

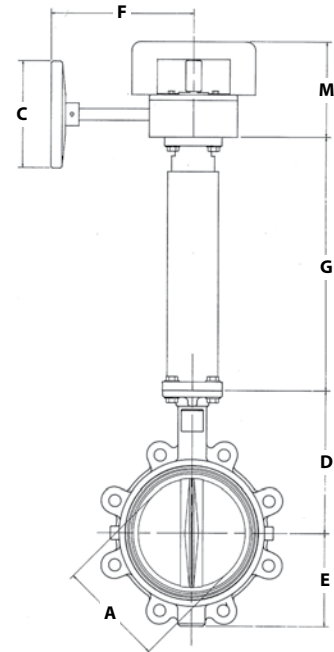

## Butterfly Post Assembly

### DIMENSIONS—WEIGHTS—QUANTITIES

Valve Size	A		C	D		E		F	G	M	Approx. Net Wt. 22" WP Incl. Wall Plate		
	Grooved	Wafer/ Lug		Grooved	Wafer/ Lug	Grooved	Wafer/ Lug				Grooved	Wafer	Lug
2	—	2.53	6	—	5.38	—	2.88	5.8	A S R E Q U I R E D	5.5	—	50	51
2½	2.42	2.90	6	4.19	5.88	3.25	3.25	5.8		5.5	51	52	53
3	2.86	3.17	6	4.44	6.13	3.59	3.38	5.8		5.5	53	53	54
4	3.84	4.17	6	5.33	6.88	4.35	4.00	7.6		5.5	56	56	59
5	—	5.17	6	—	7.38	—	4.75	7.6		5.5	—	59	63
6	5.73	6.17	6	7.11	8.00	5.3	5.25	7.6		5.5	—	62	68
8	7.71	8.17	9	8.05	9.25	7.87	6.50	7.9		5.5	76	74	80
10	—	10.17	18	—	10.50	—	8.00	9.5		6.0	—	91	104
12	—	12.17	18	—	12.00	—	9.25	9.5		6.0	—	108	128

\* 9" x 9" painted steel wall plate included with wall post assembly.

\*\* Ground line to top of indicator should be at least 36".



# TS-2M Replacement Instructions

CSA Approved • SEV Approved • UL Listed • FM Approved

## Factory Installed Supervisory Switches For Figure No. 505 Ball Valve

### Supervisory / tamper switch voltage and current ratings:

**Supervisory Switch** - for valve position supervisory / tamper indication used with U.L. listed fire alarm control panel - two (2) leads per terminal; 6 amps @ 125 volts AC 60 Hz, or 1 amp @ 28 volts DC non-inductive. **See Note 2.**

**Auxiliary Switch** - auxiliary switch which may be connected per authority having jurisdiction of auxiliary devices - one (1) lead per terminal; 6 amps @ 125 volts AC 60 Hz, or 1 amp @ 28 volts DC non-inductive.

### NOTES:

- 1) Circuit shown in set condition when valve is in non-open position.
- 2) For connection to system meeting current N.F.P.A requirements, leads A," B," "C," and "D" are used. Connections "E," "F," and "G" are for proprietary use only - **NOT intended for electrical supervision.** Please consult local authority for acceptable connection.
- 3) Refer to N.F.P.A. 13 (Installation of Sprinkler Systems), 70 (National Electrical Code), 72 (Installation, Maintenance, and Use of Protective Signaling Systems), and any other applicable standards prior to installation.
- 4) Supervisory switch is preset and tested in accordance with all applicable agency requirements at the factory. No adjustment is possible once the valve is assembled.
- 5) All lead wires are 18 AWG, 18 inches long and exit the actuator housing through a single threaded hole designed for 1/2-inch conduit fittings.

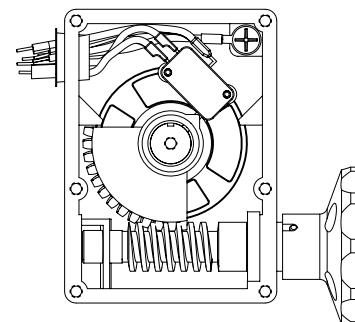
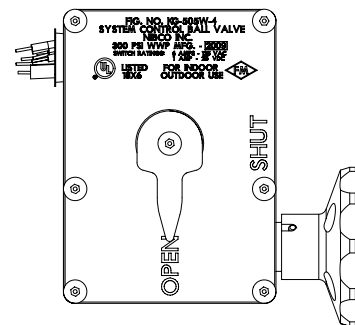
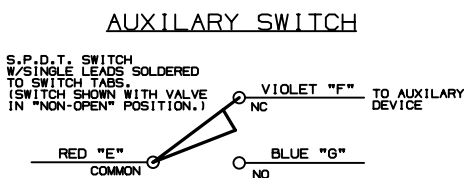
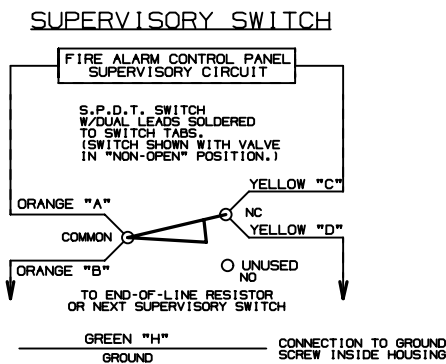

# TS4 Replacement Instructions

CSA Approved • UL Listed • FM Approved

## Factory Installed Supervisory Switches

For Figure No. GD-4765-8N/GD-6765-8N Grooved Butterfly Valves and  
WD/LD-3510-8, 2002 and later Wafer/Lug Butterfly Valves

### Tools required:

- 1/8" Allen wrench
- 5/32" Socket Pin Head Wrench (2" - 8")
- 3/16" Socket Pin Head Wrench (10" - 12")
- 9/16" Socket Wrench (2" - 8")
- 3/4" Socket Wrench (10" - 12")
- 3/16" Standard Screwdriver

1. Remove flag (A) by backing out (approximately 2 turns) hex socket set screw (B).
2. Remove one socket pin head screw (C), three socket head bolts (D) and gear operator cover (E).
3. Remove two screws holding switch assembly into housing, and one screw holding ground wire to housing and remove switch assembly.
4. Feed electrical wires of new switch assembly through hole in rear of housing. Put new switch assembly (F) into gear case with actuating arms against quadrant gear. Reinstall hold down screws and ground wire to housing.
  - Before installing cover plate, a continuity test should be performed to assure that switches are properly set.
5. Reinstall cover plate. (D)
6. Reinstall flag. (A)
7. Use and connection of auxiliary switch to be reviewed and accepted by local authority having jurisdiction.

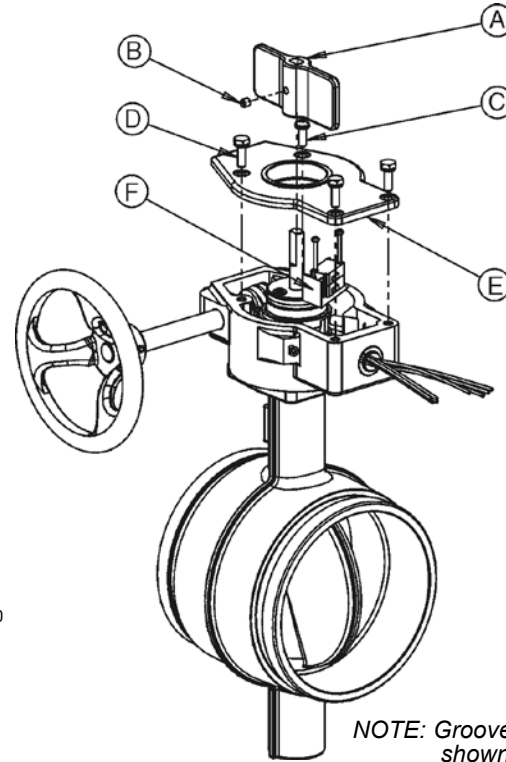

NOTE: Grooved end valve shown for illustration purposes only.

\*Instructions are same regardless of valve end connections.

### TS-4 Switch Specifications:

1 - S.P.S.T. / 1 - S.P.D.T.

Rating: 11 amps @ 125 VAC 60 Hz or  
1 amp @ 28 VDC non-inductive.

Wiring: All lead wires are 18 AWG, 18 inches long and exit actuator housing through a single hole designed for 1/2" conduit fittings.

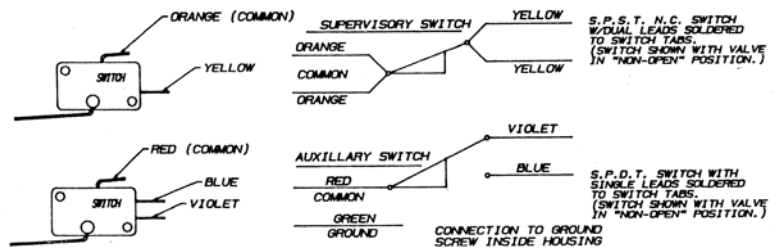

VALVE SERIES	SUPERVISION POSITION	SWITCH KIT NUMBER
GD4765-8N WD/LD3510-8*	Valve Open	T117774 PP (TS-4)
GD4765C-8N WD/LD3510C-8*	Valve Closed	T118542 PP
GD4865-8N GD6865-8N	Valve Open	T1446762 PP
GD4865C-8N GD6865C-8N	Valve Closed	T1447532 PP

\*2002 or Newer Model Wafer & Lug UL/FM Butterfly Valves

**NOTE: Reference OM&I Manual for wiring diagram.  
Gear boxes are NOT explosion proof.**



# Flow Data

## Cv Values for Valves

**Liquid Flow:**

$$Q = C_v \sqrt{\frac{\Delta P}{S}} \quad \text{or} \quad \Delta P = S \left( \frac{Q}{C_v} \right)^2$$

where . . . Q = flow rate (gallons per minute)  
 ΔP = pressure drop across valve (psi)  
 S = specific gravity of media

This equation is good for turbulent flow and for liquids with viscosities near that of water.  
 (Cv is defined as the flow in GPM that a valve will carry with a pressure drop of 1.0 PSI when the media is water at 60° F.)  
 (The specific gravity of water is 1 (one). )

**WARNING**

The Fluid Flow factors contained herein are calculated values. They are, therefore, approximations and cannot be used for highly critical flow or pressure drop calculations. For very precise flow measurements, tests must be conducted on any valve mentioned within this catalog. Throttling of Ball Valves is not recommended when valves are less than 45° open.

### VALVE SIZE

Fig. Nos.	1/4	1/2	3/4	1	1 1/4	1 1/2	2	2 1/2	3	4	5	6	8	10	12
<b>GATES</b>															
T-103-HC/104-0	5.6	17.6	32	54	97	135	230	337							
F-607-609-637 -667-697															
M-609							215	335	510	945	1,525	2,250	4,150	6,700	9,925
<b>GLOBES</b>															
KT-211-WUL/ KT-65-UL	1.16	3.64	6.65	11.1	20	28	48	70	111						
<b>CHECKS</b>															
KT-403-W(SWING)	2.5	4.8	14.3	24	43	60	102	150	238						
T-480(POPPET)	3.70	6.86	16.3	30	49	72	130								
F-908-938-968 (SWING)								243	356	665	1,073	1,584	2,937	4,730	6,985
KG-900-W/350 (GROOVED)							77	129	209	358	573	898	1740	3180	4950
KW-900-W (WAFER)								161	224	400	648	1060	1890	3340	5270
<b>BALL</b>															
KT-505W	—	—	—	57	103	143	245	183							
KG-505W	—	—	—	—	—	143	245	183							
T-580-70	—	—	—	—	44	76.1	101.4	183	390						
T-585-70	5.6	18.7	34	57	103	143	245	310							
KT-580-70UL	—	—	—	—	44	76.1	101.4	—							
KT-585-70UL	5.6	18.7	34	57	—	—	—	—							
<b>BUTTERFLY</b>															
WD/LD-3510							166	247	340	660	1,080	1,613	3,759	5,300	7,969
GD-4765/6765							145	195	290	600	—	1,600	3,450	5,800	—
GD-1765							—	—	—	—	—	—	—	5,800	—

**NOTE: Angle Globe Valves (KT67, T301W) flow is 1.25 x straight (KT65, KT211) configuration.**

# Properties of Valve Materials

ALLOY	ASTM NO.	OTHER ALLOY DESIGNATION	NOMINAL OR MAXIMUM CHEMICAL COMPOSITION									
			CARBON		CHROME	COBALT	COPPER	IRON	LEAD	MANGANESE	MOLYBDENUM	
			AL	C	Cr	Co	Cu	Fe	Pb	Mn	Mo	
Commercial Aluminum 380	SC 84 A	UNS A38000	87.0					1.0	1.3			.35
Free Cutting Brass	B16	UNS C36000						61.5				3.0
(Steam Bronze)	B61	UNS C92200		Navy "M"				88.0	.25			1.5
(Ounce Metal)	B62	UNS C83600		Composition Bronze				85.0	.30			5.0
Copper-Silicon Alloy B	B98/B99	UNS C65100						96.0	.8	.05		.7
Forging Brass	B124	UNS C37700						60.0	.3			2.0
Forging Brass	B283	UNS C37700						58.0	.3	2.5		
Brass Wire (Red Brass)	B134	UNS C23000						85.0	.05			.05
Leaded Red Brass	B140	UNS C31400						89.0	.10			1.9
(Cast)	B148	UNS C95400		Aluminum Bronze				85.0			4.0	
Aluminum Bronze (Rod)	B150	UNS C64200	7.0					91.0	.30	.05		.10
Silicon Red Brass	B371	UNS C69400						81.5	.20	.30		
Brass	B584	UNS C84400		Leaded Semi-Red				81.0	.40			7.0
Leaded Red Brass		UNS C84500	.005					78.0	.40			7.0
Leaded Nickel Bronze	B584	UNS C97600						64.0				4.0
(Wrot)	B 75	UNS C12200		Copper						99.9		
Gray Iron	A126											Class B
3% Ni Gray Iron	A126											Class B (modified)
(Ni-Resist)	A436	Type 2		Austenitic Gray Iron				.5				1.0
Ductile Iron (Ferritic)	A395							3.20				
Austenitic Ductile Iron (Ductile)	A536 65-45-12											
(Ductile)	A536 80-55-06											
(Ni-Resist)	A439 D2C				2.9	.5					2.4	1.0



NOMINAL OR MAXIMUM CHEMICAL COMPOSITION							NOMINAL PHYSICAL PROPERTIES				
NICKEL Ni	PHOS P	SILICON Si	SULFUR S	TIN Sn	TITAN- IUM Ti	TUNG- STEN W	ZINC Zn	TENSILE STRENGTH Psi	STRENGTH Psi	YIELD ELONGATION	% HARDNESS
.50		12.0		.15			.50	42,000	19,000		3.5
							35.5	50,000	20,000	15	75 HRB
1.0	.05	.005	.05	6.0			4.5	34,000	16,000	22	65 HB *500 kg
1.0	.05	.005	.08	5.0			5.0	30,000	14,000	20	60 HB 500 kg
		1.6					1.5	86,000**	20,000	11	65 HRB
							38.0	52,000	20,000	45	80 HRB
							38.0	52,000	20,000	45	78 HRB
							15.0	56,000			60 HRB
.7							9.1	50,000	30,000	7	60 HRB
								75,000	30,000	12	170 HB *3000 kg
.25		2.0		.20			.50	90,000	45,000	9	80 HRB
		4.0					14.5	80,000	40,000	15	85 HRB
	.02	.005	.08	3.0			9.0	29,000	13,000	18	55 HB *500 kg
1.0	.02	.005	.08	3.0			12.0	29,000	13,000	16	55 HB *500 kg
20.0				4.0			8.0	40,000	17,000	10	80 HB
	.02							36,000	30,000	25	45 T
	.75		.15					31,000			195 HB
3.00	.75		.15					31,000			195 HB
20.0		2.0	.12					25,000			118 HB
	.08	2.50						60,000	40,000	18	167 HB
	.08	2.50						65,000	45,000	12	160 HB
	.08	2.50						80,000	55,000	6	160 HB
24.0	.08	3.0						58,000	28,000	20	146 HB

\*Load Applied During Testing  
\*\*Allowable Range is 75,000 to 95,000

# Gate Valve Dimensions for Supervisory Switch Application

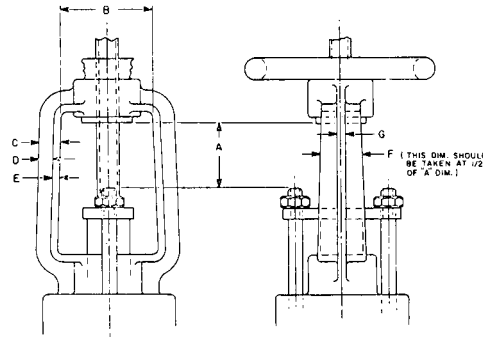

Valve	Size	A	B	C	D	E	F	G	Pitch	Stem Dia. and Thds/in	Lead	Thread Type
<b>T-104-O</b>	½	0.33	1.50	0.28	—	—	0.63	—	.08	0.44-12.00	Dble.	60° STUB
	¾	0.33	1.50	0.31	—	—	0.63	—	.08	0.44-12.00	Dble.	60° STUB
	1	0.70	1.63	0.31	—	—	0.75	—	.08	0.50-12.00	Dble.	60° STUB
	1¼	0.35	2.63	0.31	—	—	0.81	—	.11	0.56-9.00	Dble.	60° STUB
	1½	0.35	2.63	0.31	—	—	0.88	—	.11	0.56-9.00	Dble.	60° STUB
	2	0.84	2.50	0.44	—	—	0.88	—	.13	0.69-8.00	Dble.	60° STUB
<b>F-607-OTS</b>	2½	1.13	2.38	0.88	0.44	0.44	1.19	0.38	.17	0.75-6.00	Dble.	STUB ACME
	3	1.75	2.50	0.88	0.50	0.38	1.63	0.38	.17	0.75-6.00	Dble.	STUB ACME
	4	1.63	3.13	1.50	0.75	0.75	2.00	0.50	.25	1.00-4.00	Dble.	STUB ACME
	5	2.50	3.38	1.50	0.75	0.75	2.25	0.75	.25	1.00-4.00	Dble.	STUB ACME
	6	2.50	3.38	1.50	0.75	0.75	2.25	0.75	.25	1.13-4.00	Dble.	STUB ACME
	8	4.75	4.50	1.63	0.75	0.88	2.03	0.75	.25	1.25-4.00	Dble.	STUB ACME
	10	6.63	4.50	2.25	1.25	1.00	3.00	0.75	.33	1.38-3.00	Sgble.	STUB ACME
12	6.63	4.50	2.25	1.00	1.00	3.00	0.75	.33	1.50-3.00	Sgble.	STUB ACME	
<b>F-667-O/F-697-O</b>	2½	1.13	2.25	0.50	—	—	2.00	—	.17	0.75-6.00	Dble.	STUB ACME
	3	1.56	2.75	1.00	0.50	0.50	2.25	0.50	.25	1.00-4.00	Dble.	STUB ACME
	4	1.63	3.75	1.50	0.75	0.75	2.00	0.50	.25	1.13-4.00	Dble.	STUB ACME
	5	1.25	4.50	1.63	0.75	0.88	3.00	0.75	.25	1.25-4.00	Dble.	STUB ACME
	6	1.25	4.38	1.63	0.75	0.88	2.88	0.75	.33	1.38-3.00	Dble.	STUB ACME
	8	7.63	4.50	2.44	1.38	1.63	4.75	0.75	.33	1.50-3.00	Dble.	STUB ACME
	10	8.25	4.50	2.50	1.75	0.75	4.75	0.75	.50	1.88-2.00	Sgble.	STUB ACME
12	8.88	4.50	2.50	1.75	0.75	4.00	0.75	.50	1.88-2.00	Sgble.	STUB ACME	
<b>F-607-RW</b>	2½	1.55	2.56	0.76	0.45	0.31	1.43	0.31	.16	0.79 X 6.25	Sgble.	ACME
	3	2.04	2.56	0.75	0.43	0.31	1.42	0.31	.16	0.79 X 6.25	Sgble.	ACME
	4	2.55	2.95	0.79	0.39	0.39	1.67	0.39	.20	0.98 X 5.00	Sgble.	ACME
	6	4.04	3.54	0.81	0.38	0.43	1.73	0.43	.20	1.70 X 5.00	Sgble.	ACME
	8	6.04	3.98	0.92	0.45	0.47	2.11	0.47	.24	1.26 X 4.20	Sgble.	ACME
	10	7.84	4.33	0.99	0.44	0.55	2.52	0.55	.24	1.42 X 4.20	Sgble.	ACME
12	9.84	4.33	0.94	0.39	0.55	2.48	0.55	.24	1.57 X 3.60	Sgble.	ACME	

Note: All valves have left hand thread.

# Grooved Pipe Specification

Conforms to ANSI/AWWA C-606

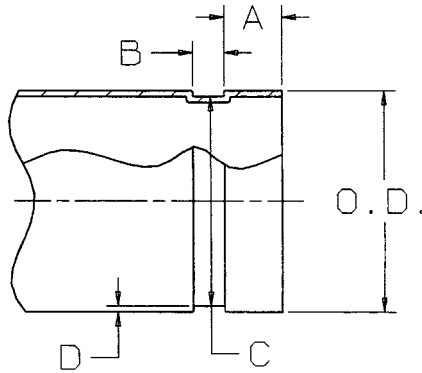

1 Nominal Size Inches	2 Pipe Outside Diameter O.D.		3 Gasket Seal A +/-0.03	4 Groove Width B +/-0.03		5 Groove Diameter		6 Groove Depth (Ref.) D	7 Min. Allowable Wall Thickness		8 Maximum Allow Flare Diameter Roll Groove
	Actual O.D.	Tolerance		Roll Groove	Cut Groove	Actual	Tolerance +0.000		Roll Groove TR	Cut Groove TC	
1 1/4	1.600	+0.016 -0.016	0.625	0.281	0.313	1.535	-0.015	0.063	0.065	0.140	1.77
1 1/2	1.900	+0.019 -0.019	0.625	0.281	0.313	1.775	-0.015	0.063	0.065	0.145	2.01
2	2.375	+0.024 -0.024	0.625	0.344	0.313	2.250	-0.015	0.063	0.065	0.154	2.48
2 1/2	2.875	+0.029 -0.029	0.625	0.344	0.313	2.720	-0.018	0.078	0.083	0.188	2.98
3	3.500	+0.035 -0.031	0.625	0.344	0.313	3.344	-0.018	0.078	0.083	0.188	3.60
4	4.500	+0.045 -0.031	0.625	0.344	0.375	4.344	-0.020	0.083	0.083	0.203	4.60
5	5.563	+0.056 -0.031	0.625	0.344	0.375	5.395	-0.022	0.084	0.109	0.203	5.66
6	6.625	+0.063 -0.031	0.625	0.344	0.375	6.455	-0.022	0.085	0.109	0.219	6.73
8	8.625	+0.063 -0.031	0.750	0.469	0.438	8.441	-0.025	0.092	0.019	0.238	8.80
10	10.750	+0.063 -0.031	0.750	0.469	0.500	10.562	-0.027	0.094	0.134	0.250	10.92
12	12.750	+0.063 -0.031	0.750	0.469	0.500	12.531	-0.030	0.109	0.156	0.279	12.92

**COLUMN 1:**

-Normal IPS pipe size outside diameter.

**COLUMN 2:**

-Maximum Deviation from square-cut ends for 1.25" thru 3" is 0.03"; for 4" thru 6" is 0.045" and for 8" and above is 0.06".

**COLUMN 3:**

-To provide a leak-tight seal, the gasket seating area pipe shall be free from roll marks, indentations, paint scale, dirt, chips, grease and rust, etc.

**COLUMN 4:**

-Groove Width: Groove bottom to be free from loose dirt, chips, rust and scales. Bottom and grooves to be radiused and the vertical wall of grooves must provide at least 0.03" vertical side for proper assembly and coupling.

**COLUMN 5:**

-Groove Outside Diameter: The groove must be concentric to the pipe circumference. Groove must be within the diameter tolerance indicated.

**COLUMN 6:**

-Groove Depth: For reference only. (Refer to Column 5)

**COLUMN 7:**

-Minimum allowable wall thickness to which the pipe may be roll grooved or cut grooved.

**COLUMN 8:**

-Maximum allowable pipe end flare diameter. Measured at the most extreme pipe ends.

# Figure Number Comparisons

## GATE, GLOBE, CHECK AND INDICATOR POST

NIBCO	KENNEDY	MUELLER	UNITED	CLOW	VICTAULIC
T-103-HC	39NS	—	—	—	—
T-104-0	66	—	18	—	—
KT-65-UL, KT-211-UL	97SD*	—	1255UL	—	—
KT-291-W3*	220*	—	76*	—	—
KT-67-UL, T-301-W	98SD	—	1265UL	—	—
T-331-HC	936	—	—	—	—
KT-403-W*	440SD*	—	995*	—	—
F-607-OTS	68	A2073-6	—	F5733	—
F-607-RW	8068A (C509)	R-2361-6	—	F6136	—
	7068A (C515)				
F-609	701	A2052-6	—	F5722	—
F-609-RW	8701ASS (C509)	P2361-6	—	F6102	—
	7701SS (C515)				
M-609	71	A2052-20	—	F5725	—
M-609-RW	8071SS (C509)	P2361-16	—	F6100	—
	7071SS (C515)				
F-697-0	3068	—	—	—	—
F-908W	126A	A2122-6	—	F5347R	—
KW-900-W	706	A2102	90	—	—
NIP-1AJ	2945A	A20806	—	2945A	773
NIP-2AJ	641-13	A20813	—	F5761	774

\*Not UL Listed

## BALL & BUTTERFLY

NIBCO	MILWAUKEE	VICTAULIC	STOCKHAM	UNITED	KENNEDY
T-585-70*†	—	—	T285	—	775*†
KT-505W-8	BB-SC502	728	—	—	—
KG-505W-8	BB-SC100				
WD3510-8	—	—	—	—	W300
LD3510-8	—	—	—	—	93WI
GD-4765-8N	—	705	—	—	G300
KT-580/585-70UL	—	722	—	—	—

\*Not UL Listed

†Not FM Approved

# A Typical Fire Protection Sprinkler System

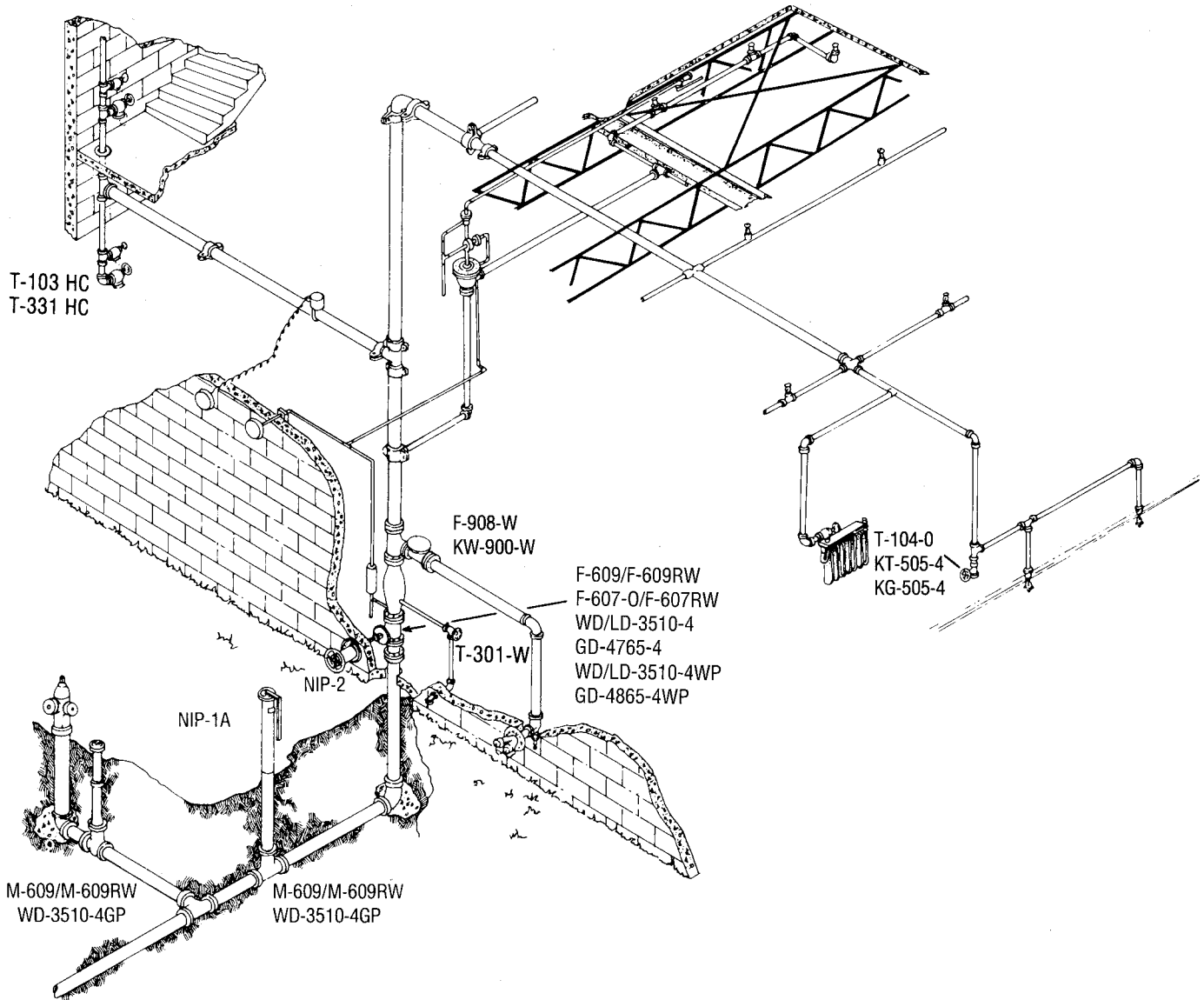

*Schematic courtesy of Rick Perella*



**NIBCO INC. 125% LIMITED WARRANTY**

Applicable to NIBCO INC. Pressure Rated Metal Valves

NIBCO INC. warrants each NIBCO pressure rated metal valve to be free from defects in materials and workmanship under normal use and service for a period of five (5) years from date put into service.

In the event any defect occurs which the owner believes is covered by this warranty, the owner should immediately contact NIBCO Technical Services, either in writing or by telephone at (888) 446-4226 or (574) 295-3000. The owner will be instructed to return said product, at the owner's expense, to NIBCO INC., or an authorized representative for inspection. In the event said inspection discloses to NIBCO INC.'s satisfaction that said valve is defective, it will be replaced at NIBCO INC.'s expense. Replacements shall be shipped free of charge to the owner. In the event of the replacement of any valve, NIBCO INC. shall further pay the owner the greater of Twenty-Five (25%) Percent of the price of the valve according to NIBCO INC.'s published suggested list price schedule in effect at the time of purchase, or Ten (\$10.00) Dollars, to apply on the cost of the installation of said replacement valve.

TO THE EXTENT PERMITTED BY LAW, THIS WARRANTY SPECIFICALLY EXCLUDES INCIDENTAL AND CONSEQUENTIAL DAMAGES OF EVERY TYPE AND DESCRIPTION RESULTING FROM ANY CLAIMED DEFECT IN MATERIAL OR WORKMANSHIP, INCLUDING BUT NOT LIMITED TO, PERSONAL INJURIES AND PROPERTY DAMAGES. Some states or countries do not allow the exclusion or limitation of incidental or consequential damages so these limitations may not apply to you. TO THE EXTENT PERMITTED BY LAW, IMPLIED WARRANTIES OF MERCHANTABILITY AND FITNESS FOR A PARTICULAR PURPOSE ARE LIMITED IN DURATION.

This warranty gives you specific legal rights, and you may also have other rights which vary from state to state and country to country.



## how to order

State quantity, figure number and size for each valve you wish to order. See individual valve catalog pages for specific or special product designations.

### HOW MANY TO ORDER

NIBCO valves are decimal packed for your convenience in handling, shipping and stock-keeping. Number in master carton varies with item.

### POLICY ON RETURNS TO FACTORY

NO NIBCO valves are to be returned without prior written agreement. Transportation must be prepaid. A 20% charge will be made to cover cost of rehandling and reinspection.

### TECHNICAL ASSISTANCE

Engineers, contractors, wholesalers or manufacturers may obtain special or technical assistance from any factory representative of NIBCO. Write, fax or phone.

NIBCO INC.  
World Headquarters  
1516 Middlebury Street  
Elkhart, IN 46516-4740  
USA

Phone: 1.574.295.3000

Fax: 1.574.295.3307

Technical Service Phone: 1.888.446.4226

Fax: 1.888.336.4226

To the best of our knowledge the information contained in this publication is accurate. However, NIBCO® does not assume any liability whatsoever for the accuracy or completeness of such information. Final determinations of the suitability of any information or product for the use to be contemplated is the sole responsibility of the user. The manner of that use, and whether there is any infringement of patents, is also the sole responsibility of the user.

globally connecting you at all levels

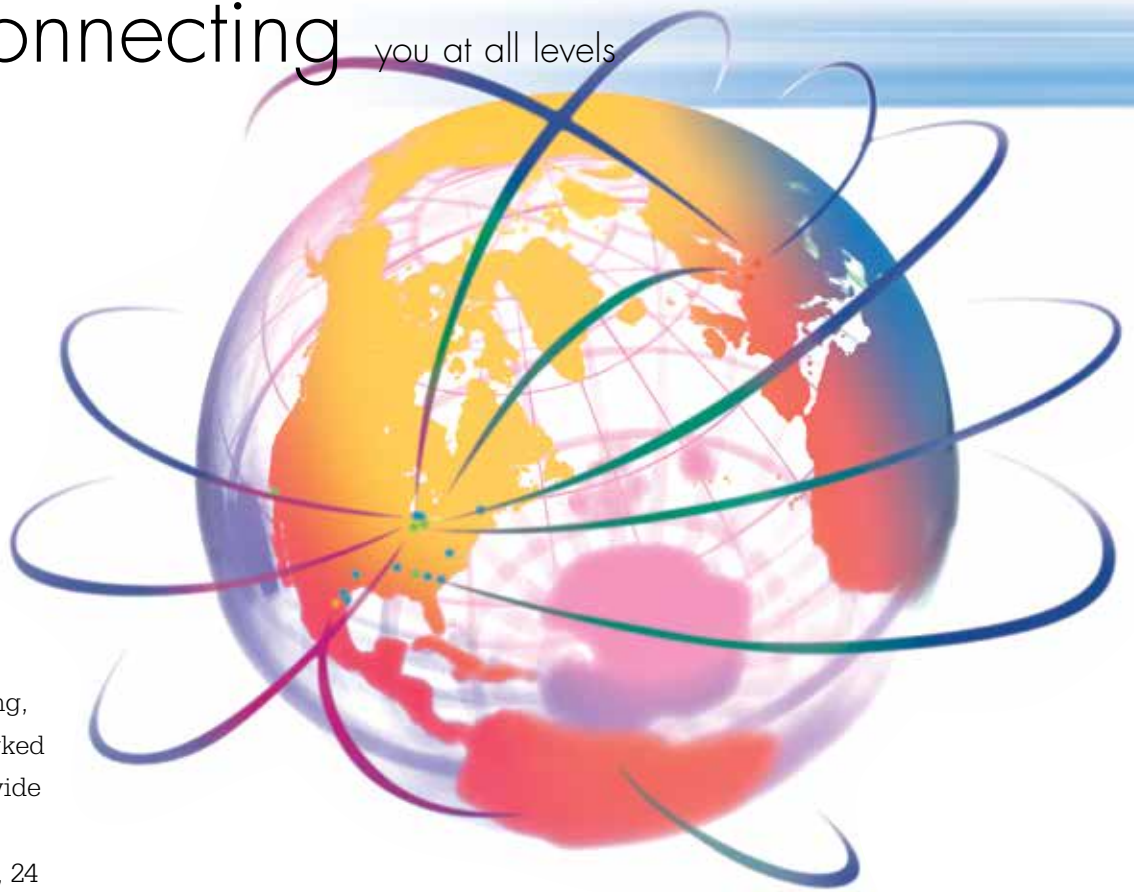

It's a new age of business, and a new way at NIBCO. From Elkhart, Indiana to Lodz, Poland, and points beyond, our company has integrated manufacturing, distribution, and networked communications to provide a seamless source of information and service, 24 hours a day, 7 days a week. But this integration hasn't happened overnight. It's been part of a long-term strategic process that has pushed us to reconsider every aspect of our business. The result? We're a vertically integrated manufacturer with the products and systems in place to deliver low cost and high quality. NIBCO products are manufactured under a Quality Management System conforming to the current revision of ISO-9001 International Standards. We know the flow control industry is only going to get more demanding, and we are more than ready. We will continue to lead. That's what NIBCO is all about.



# FEATURING NIBCO® SYSTEMS

C-FPV-0516

NIBCO® PEX Piping Systems • NIBCO® Press System®

## FITTINGS



Wrot and cast copper pressure and drainage fittings • Cast copper alloy flanges  
• Wrot and cast press fittings • ABS and PVC DWV fittings • Schedule 40 PVC pressure fittings • CPVC CTS fittings • CPVC CTS-to-metal transition fittings  
• Schedule 80 PVC and CPVC systems • CPVC metric piping systems  
• CPVC BlazeMaster® fire protection fittings • Lead-Free\* fittings

BlazeMaster® is a registered trademark of The Lubrizol Corporation.  
\*Weighted average lead content ≤0.25%

## VALVES & ACTUATION

Pressure-rated bronze, iron and alloy-iron gate, globe and check valves • Pressure-rated bronze ball valves • Boiler specialty valves • Commercial and industrial butterfly valves • Circuit balancing valves • Carbon and stainless steel ball valves  
• ANSI flanged steel ball valves • Pneumatic and electric actuators and controls  
• Grooved ball and butterfly valves • High performance butterfly valves • UL/FM fire protection valves • MSS specification valves • Bronze specialty valves • Low pressure gate, globe, check and ball valves • Frostproof sillcocks • Quarter-turn supply stops • Quarter-turn low pressure valves • PVC ball valves • CPVC CTS ball valves • Bronze & Iron Y-Strainers • Lead-Free\* valves • Coil-Connect® Kits

\*Weighted average lead content ≤0.25%



## CHEMTROL®



Thermoplastic pipe, valves and fittings in PVC, Corzan® CPVC, polypropylene and PVDF Kynar® • Pneumatic and electric actuation systems

Corzan® is a registered trademark of The Lubrizol Corporation. • Kynar® is a registered trademark of Arkema Inc.

## eNIBCO

EDI—Electronic Data Interchange • VMI—Vendor Managed Inventory  
• NIBCO.com • NIBCOpartner.com



**NIBCO®**  
AHEAD OF THE FLOW®

**NIBCO INC.**  
**WORLD HEADQUARTERS**  
WEB: [www.nibco.com](http://www.nibco.com)

1516 MIDDLEBURY STREET  
ELKHART, IN 46516-4740  
USA

DOMESTIC CUSTOMER SERVICE  
PHONE: 800.234.0227  
FAX: 800.234.0557

TECHNICAL SERVICE  
PHONE: 888.446.4226  
FAX: 888.336.4226

INTERNATIONAL OFFICE  
PHONE: +1/574.295.3327  
FAX: +1/574.295.3455