





NOTES:

- (N1) 1. FIT / FORM / FUNCTION SHALL FOLLOW PS-E.008.
- (N2)  TORQUE REQUIRED TO TIGHTEN THE SCREWS 24-26 LB-IN
- (N3)  APPLY DOW CORNING 700 SILICONE TO SEAL MAGNETS FROM MOISTURE
- (N4)  ENSURE TO INSTALL MAGNETS WITH NEGATIVE "-" MARKED SIDE FACING UP
TEST POLARITY UPON ASSEMBLY:
THE TESTER SHOULD SHOW "N" AND LIGHT SHOULD TURN RED
- (5)  2-11 1/2 NPSM
EXT. MAJOR DIA. MAX. 2.332 MIN. 2.320
EXT. PITCH DIA. MAX. 2.275 MIN. 2.269

BILL OF MATERIAL (CURRENT LEVEL)

ITEM	PT/ASSY	DESCRIPTION	TYPE	QTY.
1	50968	4" SQUARE DRAIN THROAT	PART	1
2	92523	SUPPER DISK MAGNET	PART	4
3	50933	4" SQUARE DRAIN FLANGE	PART	1
4	92498	SCRW, 10-24 X 1/4 SKT BUTTON HD SS	PART	4
5	50954	PROTECTIVE COVER 4"	PART	1

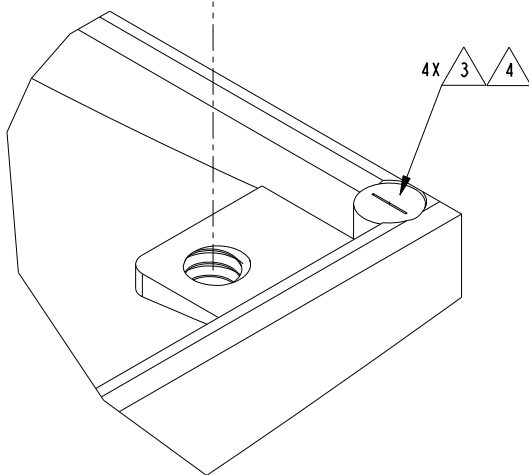
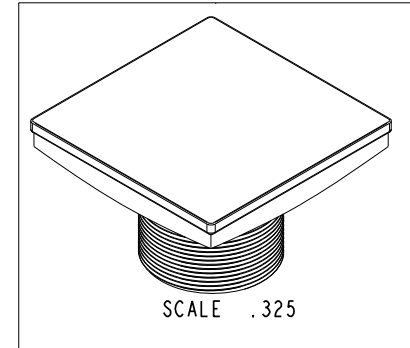
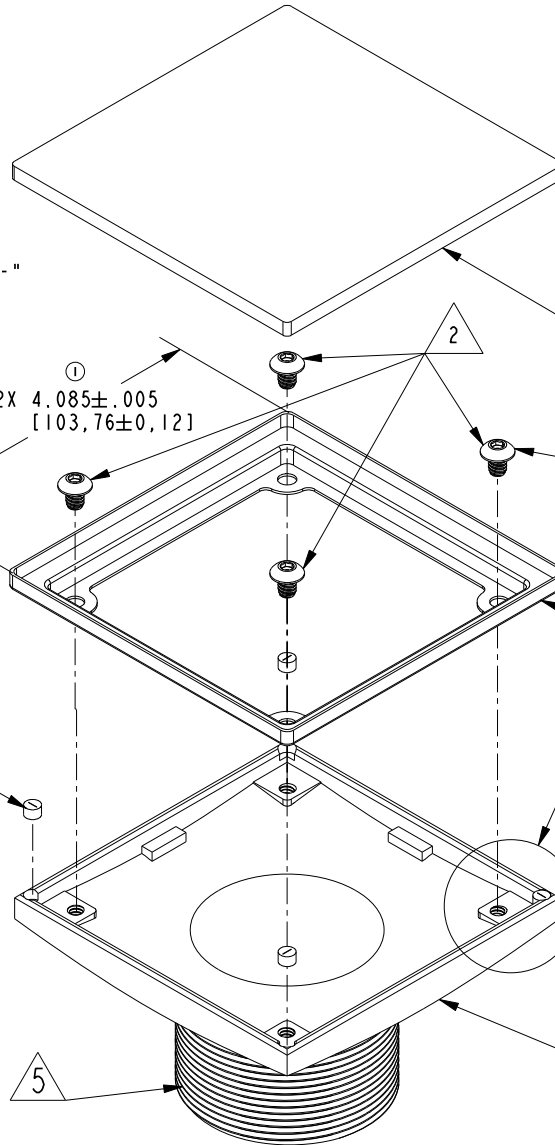

DETAIL A
SCALE 2.000

-	G	EN-3163	10/12/16	J.M.
-	F	EN-2854	01/05/16	J.M.
-	E	EN-2828	10/24/14	-
-	D	EN-2401	01/04/13	-
-	C	EN-2380	12/13/12	-
-	B	EN-2228	07/26/12	-
-	A	EN-2144	04/18/12	-
-	-	EN-1714	03/06/12	-
ZONE	REV	DESCRIPTION	DATE	APPROVED

COPYRIGHT 2005 BRASSTECH, INC. THESE DRAWINGS AND THE DESIGNS DEPICTED HEREIN ARE THE PROPRIETARY PROPERTY OF BRASSTECH. ANY USE OR REPRODUCTION IS SUBJECT TO THE EXPRESS APPROVAL OF BRASSTECH. UNAUTHORIZED USE IS STRICTLY PROHIBITED. ALL RIGHTS RESERVED.

TESTING	ASSEMBLY	PLATING	POLISHING	MACHINING	TOOLING	FIXTURE #	APPLICATION
-	-	-	-	-	-	-	REMOVE ALL BURRS AND SHARP EDGES
-	-	278-01	278-01	-	-	-	-
-	-	NEXT ASSY	USED ON	-	-	-	-
-	-	-	-	-	-	-	-

UNITS ARE: INCHES [MM]
TOLERANCES ARE:
FRACTIONS DECIMALS ANGLES
 $\pm 1/16"$.XX $\pm .06$ [1,5] $\pm 1"$
X.XXX DENOTES CRITICAL DIMS.
ALL THREADS ARE CRITICAL

DRAWN JINSON 01/05/16
CHECKED RAVINDRA 01/05/16
APPROVED J.M 01/05/16

BRASSTECH 2001 CARNEGIE AVE.
INCORPORATED SANTA ANA, CA 92705
(949) 417-5207

4" THROAT WITH 2" IPS
OUTLET

DWG NO. 277-01 REV G

SCALE .500 REF. - SHEET 1 OF 2

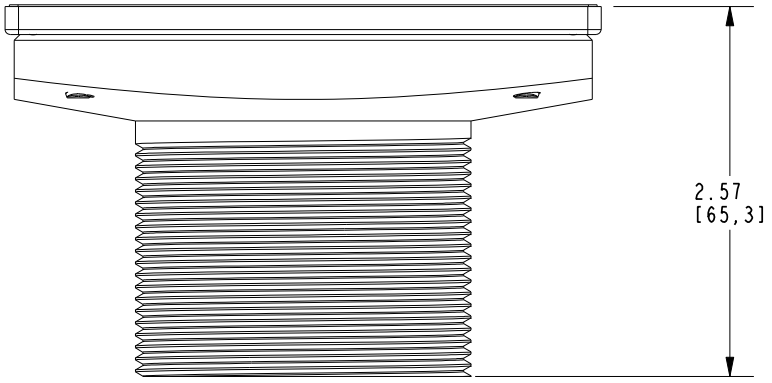
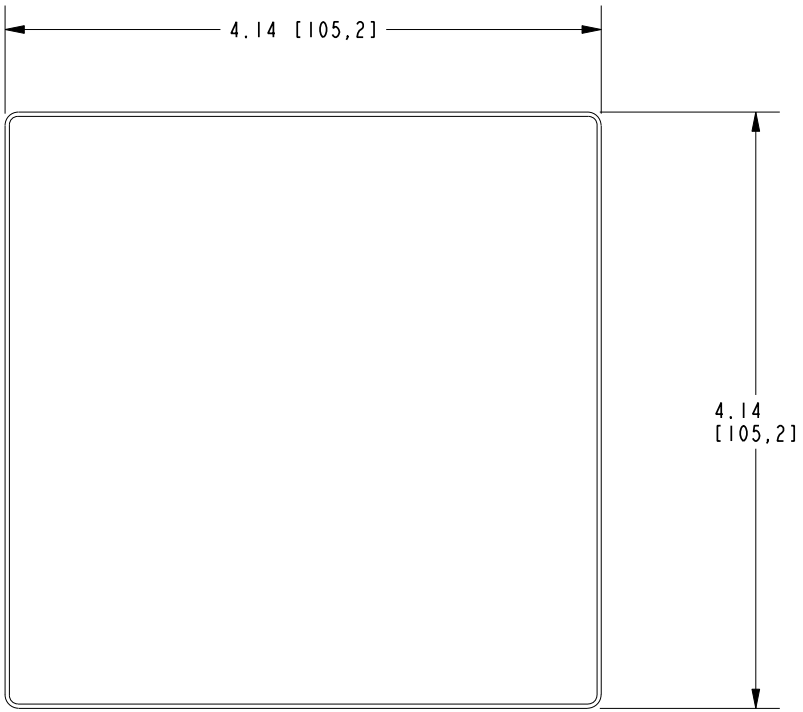

BRASSTECH		2001 E. CARNEGIE AVE.	
INCORPORATED		SANTA ANA, CA 92705	
		(949) 417-5207	
DWG NO.	277-01	REV	G
SCALE .750	REF. -	SHEET 2	OF 2