



Mission Rubber Company LLC

1660 Leeson Lane
 Corona, CA 92879
 (800) 854-9991 • Fax (800) 637-4601
 missionrubber.com

MISSION
 RUBBER COMPANY

*When there is a need
 to withstand shear
 forces, deflection &
 improved alignment*

MEETS:
 ASTM C 425
 ASTM C 1173
 ASTM A240/A240M
 CSA B602
 UPC 4224



Flex-Seal® ARC Coupling - Submittal MR01 ARC Series

*Performance Couplings for Similar and Dissimilar Pipe Sizes
 and Materials*

PROJECT _____

ENGINEER _____

CONTRACTOR _____

MATERIALS	
Worm Drive Clamp	300 series ASTM stainless steel
Nut & Bolt Clamp	316 series ASTM stainless steel
Shield	301 series ASTM stainless steel 0.012" thick
Gasket	This gasket is fabricated from a compound with high-quality elastomeric properties to meet physical testing.

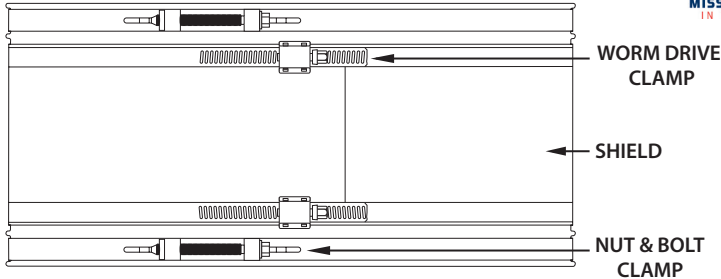

WORM DRIVE CLAMP DETAILS

NUT & BOLT CLAMP DETAILS

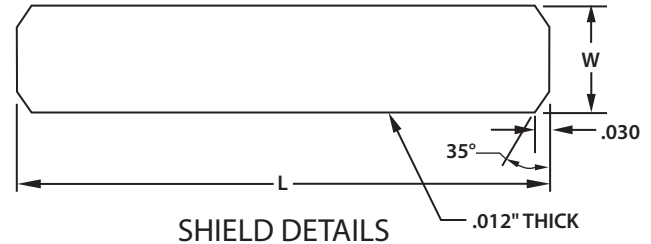

SHIELD DETAILS

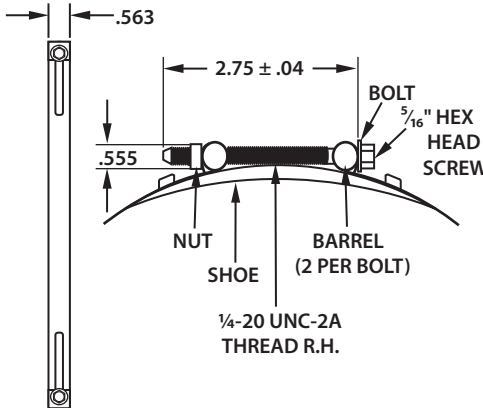
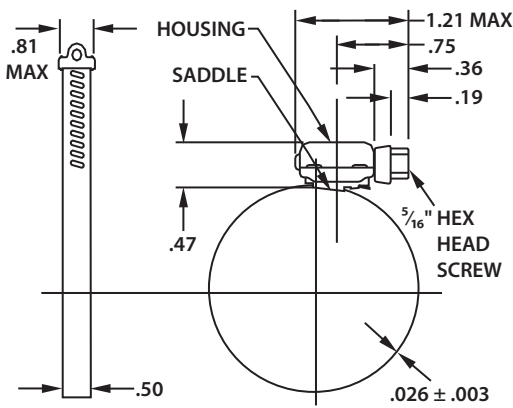

SEALING GASKET DETAILS

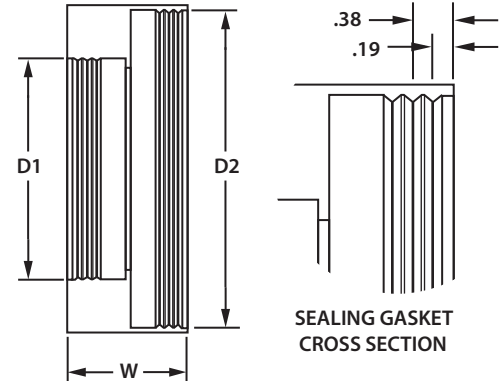

MISSION REFERENCE MR01 SERIES	SHIELD DIMENSIONS		SEALING GASKET DIMENSIONS		
	L	W	D1	D2	W
MR01 44 ARC	19.75	1.88	5.40	5.40	4.00
MR01 54 ARC	24.50	3.38	5.40	6.56	6.00
MR01 55 ARC	24.50	3.38	6.56	6.56	6.00
MR01 64 ARC	27.50	3.38	5.40	7.80	6.00
MR01 66 ARC	27.50	3.38	7.80	7.80	6.00
MR01 86 ARC	34.50	3.81	7.80	10.00	6.00
MR01 88 ARC	34.50	3.81	9.85	9.85	6.00
MR01 1008 ARC	42.50	3.81	10.00	12.45	6.00
MR01 1010 ARC	42.50	3.81	12.45	12.45	6.00
MR01 1212 ARC	50.50	3.81	14.80	14.80	6.00
MR01 1515 ARC	62.38	5.75	18.30	18.30	10.00
MR01 1818 ARC	71.50	5.75	22.30	22.30	10.00
MR01 2121 ARC	86.25	5.75	25.90	25.90	10.00
MR01 2424 ARC	100.13	5.75	30.30	30.30	10.00
MR01 2727 ARC	107.00	5.75	32.50	32.50	10.00

TEST	GASKET PHYSICAL TESTS (ASTM C 425)	ASTM C 425
Tensile Strength	1000 PSI minimum	D412
Elongation	250% minimum	D412
Durometer (Shore A)	55 minimum 70 maximum	D2240
Accelerated Aging	85% of original tensile strength 85% of original elongation All determined after oven aging at 70°C for 7 days	D573
Compression Set	20% maximum of original deflection	D395
Ozone Cracking	No visible cracking at 2X magnification of the gasket after 24 hours exposure in 0.5 PPHM ozone concentrations at 40°C. Testing and inspection to be on gasket which is loop-mounted to give approximately 20% elongation of outer surface.	D1149
Water Absorption	5% maximum by weight after 7 days at 70°F	D471

Used to Join - MR01 ARC Series couplings are used to join clay to clay.

Mission's Flex-Seal® ARC Adjustable Repair Coupling is a shielded sewer repair coupling designed to provide superior performance and excellent resistance to heavy earth loads, shear forces, deflection and improved alignment. Coupling consists of two (2) 300 series stainless steel worm drive clamps, two (2) or four (4) surgical grade 316 stainless steel Nut & Bolt clamps and a heavy duty 301 series stainless steel shield, over a molded one-piece elastomeric sealing gasket. MR01 ARC Series couplings are available in sizes 4" to 27".

Leak-Proof Seal - Increased band tension of surgical grade 316 stainless steel Nut & Bolt clamps ensure a water-tight, leak-proof and root-proof seal that is resistant to both infiltration and exfiltration. Axially slotted clamps enable bands to tighten independently to accommodate variances in the outside diameters of the pipe to be joined. Sealing "O" Rings are installed under each sealing clamp to prevent pipe slippage and create a more positive seal.

Corrosion Resistant - Surgical grade 316 stainless steel Nut & Bolt clamps and 300 series stainless steel components provide outstanding protection in severe environments; such as marine applications, poorly aerated or moist soils, contaminated ground conditions (particularly industrial fill sites) and where the ground water contains chloride, sulfates or bicarbonates.

Superior Rigidity - .012" thick 301 series stainless steel shield provides for superior load bearing control between the coupling and pipe surface. The coupling's rugged construction provides excellent sealing properties, and the stainless steel shield provides excellent resistance to shear forces and helps with alignment, while maintaining flexibility.

Withstands Tension and Compression - Synthetic rubbers permit a substantial degree of distortion without change in basic physical resistance, unlike other manufacturers' thermoplastic coupling materials. Molded synthetic rubber gasket is strong, durable and resilient to ultraviolet rays, ozone, fungus growth, natural erosive properties of soil and normal sewer gases. More pliable and easier to install in cold weather applications than an elastomeric PVC gasket.

Pre-Set Calibration - All ARC couplings are designed to be installed with a pre-set torque wrench calibrated to 60 in/lbs. maximum to accommodate the 300 series stainless steel 5/16" hex head screw.