

COMPRESSION

BRASS FITTINGS

BALL CHECK VALVE - Min. Working pressure 3 psi.

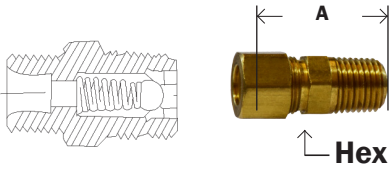

Part #	Tube OD x Male NPTF	A	Hex	Approx. Wt. Lbs.	List Price
18-092	1/8" x 1/8"	0.78	0.44	0.04	11.63
18-094	1/4" x 1/8"	0.88	0.44	0.04	12.20
18-096	3/8" x 1/4"	1.16	0.56	0.08	16.11

63 263 63A

TEE

SAE# 060401

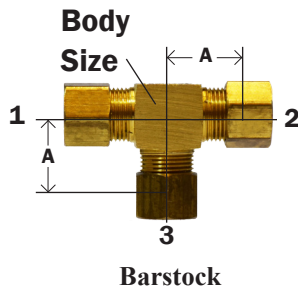
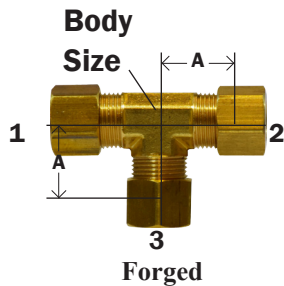

Part #	Size	A	Body Size	Approx. Wt. Lbs.	List Price
18-101	1/8"	0.61	0.37	0.04	12.96
18-101B*	1/8"	0.62	0.33	0.04	11.29
18-102	3/16"	0.59	0.36	0.08	5.80
18-102B*	3/16"	0.60	0.38	0.08	8.20
18-103	1/4"	0.63	0.36	0.10	5.35
18-103B*	1/4"	0.62	0.49	0.10	10.20
18-104	5/16"	0.72	0.50	0.13	8.49
18-104B*	5/16"	0.60	0.50	0.14	13.33
18-105	3/8"	0.75	0.50	0.16	7.34
18-105B*	3/8"	0.73	0.59	0.16	13.55
18-106	1/2"	0.94	0.59	0.22	14.36
18-106B*	1/2"	0.94	0.69	0.24	30.90
18-107	5/8"	1.06	0.69	0.28	15.31
18-108	3/4"	1.22	0.88	0.32	49.88
18-109	7/8"	1.25	0.94	0.34	40.07

* Barstock

64 264C

FORGED REDUCING TEE

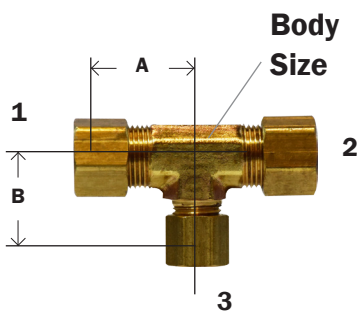

Part #	Size 1 x 2 x 3	A	B	Body Size	Approx. Wt. Lbs.	List Price
18-114	1/4" x 1/4" x 1/8"	0.62	0.59	0.38	0.09	7.68
18-110	1/4" x 1/4" x 3/8"	0.69	0.75	0.50	0.14	16.99
18-111	3/8" x 1/4" x 1/4"	0.75	0.69	0.50	0.12	10.44
18-115	3/8" x 3/8" x 1/4"	0.75	0.69	0.50	0.14	7.67
18-116	1/2" x 1/2" x 1/4"	0.94	0.81	0.59	0.16	14.50
18-117	1/2" x 1/2" x 3/8"	0.94	0.81	0.59	0.24	15.60
18-118	5/8" x 5/8" x 3/8"	1.06	0.94	0.69	0.28	18.66
18-119	5/8" x 5/8" x 1/2"	1.06	1.06	0.69	0.30	20.66

64-R

our life is what our thoughts make it. — Marcus Aurelius