



INSTALLATION MANUAL

Outdoor Series

RP-SAL-8W-50K-SF-GY-G1, RP-SAL-30W-50K-SF-GY-G1

Warning and Attention:

1. The average sunshine in the installation area should be above 3.5h/day in order to ensure full function of the lighting fixture. .
2. Before installation, please ensure the light pole foundation is solid enough to withstand lighting fixture.
3. . Position the lighting fixture to optimize its exposure to sunlight. Always face the equator (solar panel to face south if in northern hemisphere for example).
4. In order to allow self-cleaning, please have a minimum angle of 15 degrees.
5. For best results install on a day with full sunlight. If the battery is totally dead, please allow the battery to charge under sun before programming it accordingly. (Please remove small plastic from remote)
6. Adjust the angle of the fixture to optimize its exposure to sunlight. Adjust the LED module angle toward the area to be illuminated.
7. The fixture is on once the power button on the remote is pressed and aimed at the fixture. Please make sure the panel is installed under direct sunlight. The red light should be flashing, indicating that it is charging. You can also hit the test button on the remote to insure that it is on and will receive 2 flashes back from the LED light.
8. Select the necessary operation mode with the remote control. Please refer to the instruction manual of the remote control for further information. Note: The remote has a range of 30ft
9. Use the dedicated tool to disassemble the anti-theft screws. **Note: Dedicated tool is included in the box of each lamp.**
10. The lighting fixture will automatically turn on at night and turn off during daylight.
11. Please select the right operating mode according to the local legislation needs and the local sunshine conditions.

Modes:

Motion Sensor Mode, Time Control Mode, and Constant Brightness Mode (See page 2 for details on mode options)

12. The battery of the LEDSAL solar street light fixture will stop charging when the ambient temperature is below 32°F or above 149°F. The working temperature of the solar fixture is -4°F (-20°C) to +122°F (+50°C). When operating in an environment with a temperature lower than 32°F (0°C) or equal to or above 149°F (65°C) the battery will stop charging, even if there is sunlight. In that temperature range the battery self protects which will show a flashing red indicator light. This feature helps protect the battery from damage. The solar area light will still light even in those extreme temperatures until the battery is completely depleted.
- 13.) The working temperature of the solar fixture is -4°F~+122°F. When operating in an environment with a temperature lower than 32°F; the battery will stop charging, even if there is sunlight, but the lighting fixture can still be discharged if you want to use.
14. When the ambient temperature is $\leq 32^{\circ}\text{F}$ or $\geq 149^{\circ}\text{F}$, the battery will turn into self-protection mode.
 - a. When the battery charge is only 40%, the luminance will automatically be reduced by half.
 - b. When the green indicator begins to flicker slowly, it means that there is only 10% battery charge.

c. When there is only 5% battery charge, the luminaire will automatically shut down, then enter the protection state and not discharge.

Application Item:

Item	MODEL	WATT	LUMEN	NET WEIGHT	DIMMING
A	RP-SAL-8W-50K-SF-GY-G1	8W	1600LM	11.61 lbs	Use the remote control to adjust
C	RP-SAL-30W-50K-SF-GY-G1	30W	6000LM	29.76 lbs	Use the remote control to adjust

Red indicator:

1. When charging, the red light will be flashing slowly
2. When fully charged, the red light will stay lit
3. When the red light is blinking fast, this indicates that the battery is not charging
*(Flashing quicker than a second)

Green indicator:

1. Battery power more than 10%, the green light will stay lit
2. Battery power less than 10%, the green light flash will slowly

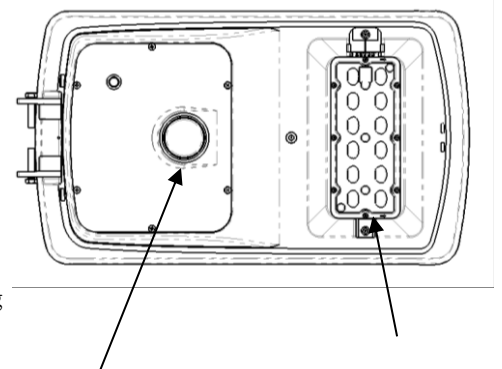

Red and green indicator light-emitting module
Microwave and PIR receiver

Mode switching indication of remote control:

The light module will flash twice when the light fixture receives the signal from remote control

Introduction of Remote Control button

Note: Remote control included.

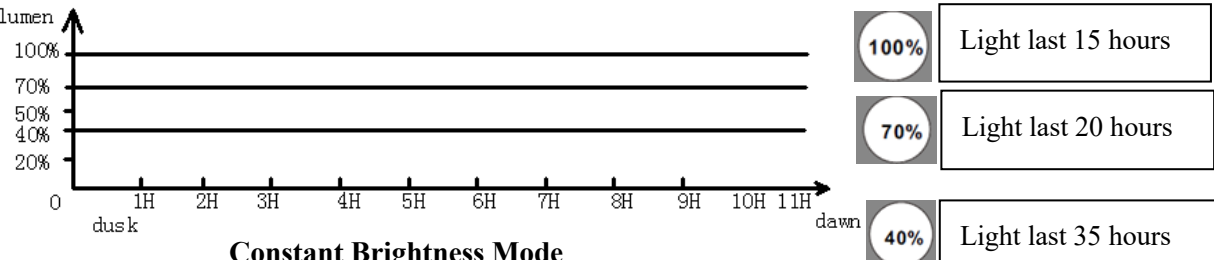
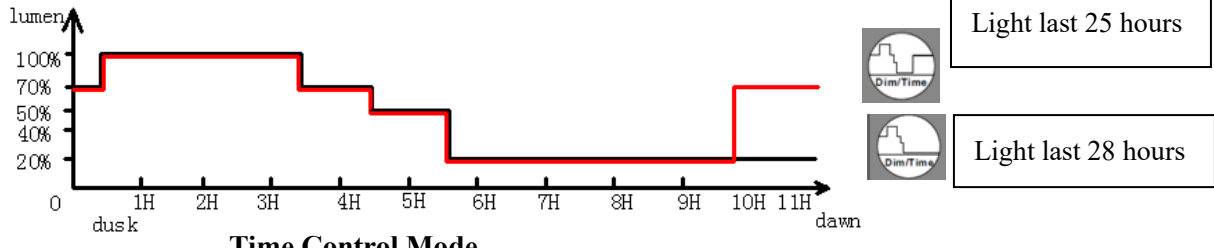
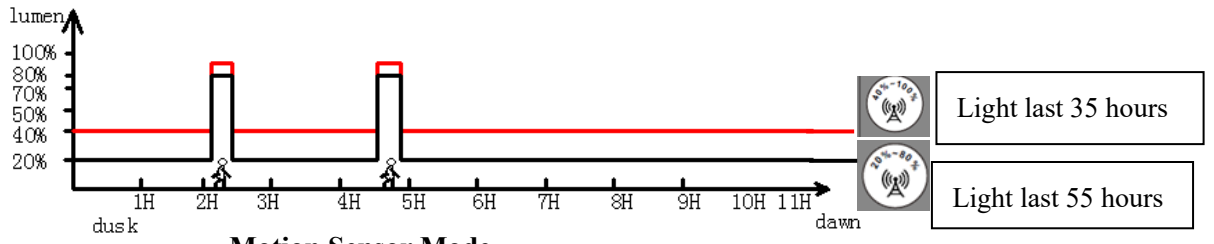

“ON/ OFF” Working/Standby key



Motion sensor mode

Suitable for areas and seasons with less sunlight time



Time control mode

Suitable for areas and seasons with average sunlight time



Constant brightness mode

Suitable for areas and seasons with more sunlight time



Test mode: Test the function of the product is normal



Select the 4 hour option or 8 hour option to set to a predetermined run time instead of running from dusk til dawn. These buttons only apply to the constant brightness mode.



Cancels preset time modes that were selected, either 4 or 8 hours

Installation Accessories:

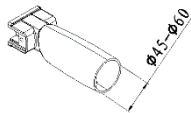
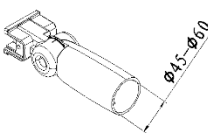
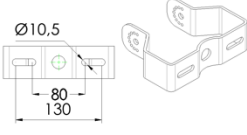
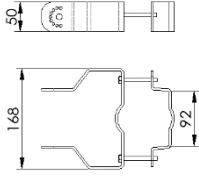
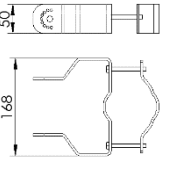
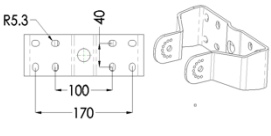
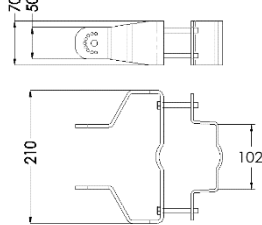
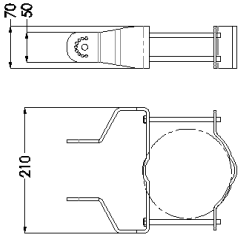
Item	Fixed arm mounting	Slip fitter mounting	U-Trunnion mounting	Square-Hoop Mounting	Round -Hoop Mounting
8W Solar Streetlight			 <p>1. Wall mounted 2. Square pole above 3.94 in</p>	 <p>1. Round pole : 1.96 in - 3.54 in 2. Square pole: 1.96 in - 3.54 in</p>	 <p>Round pole: 1.96 in - 4.33 in</p>
30W Solar Streetlight	1.77 – 2.63 in	1.77 – 2.63 in	 <p>Wall mount or Square pole wider than 4.75 in</p>	 <p>1. Round pole: 2.36 in -3.94 in or Square pole: 1.97 in - 3.94 in</p>	 <p>Round pole: 1.97 in - 4.72 in</p>

Installation:

1. Take out the fixture and the tools from the package.
2. Remove the small plastic on the bottom of the remote and press the power button on the remote. Cover up the solar panel and check if the light module turns on. If the fixture does not turn on please place it under sunlight as the battery may be dead and just needs to charge.

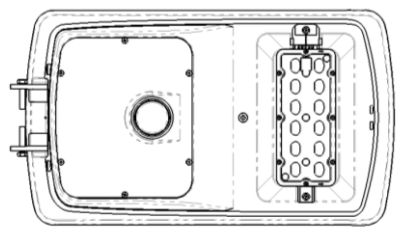
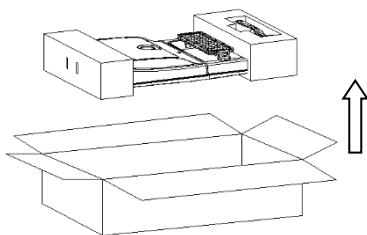

3. Use the remote control to test the function and set up the necessary mode. The light module will flash twice when receive the signal from remote control (The default setting is motion sensor mode 40%-100%).



5. Using the dedicated tool to assemble the light body and the mounting accessories, adjust the light fixture and LED module to the suitable angle.

6. Install the light to the round pole, square pole or wall, tighten the screws and the nuts when fixed

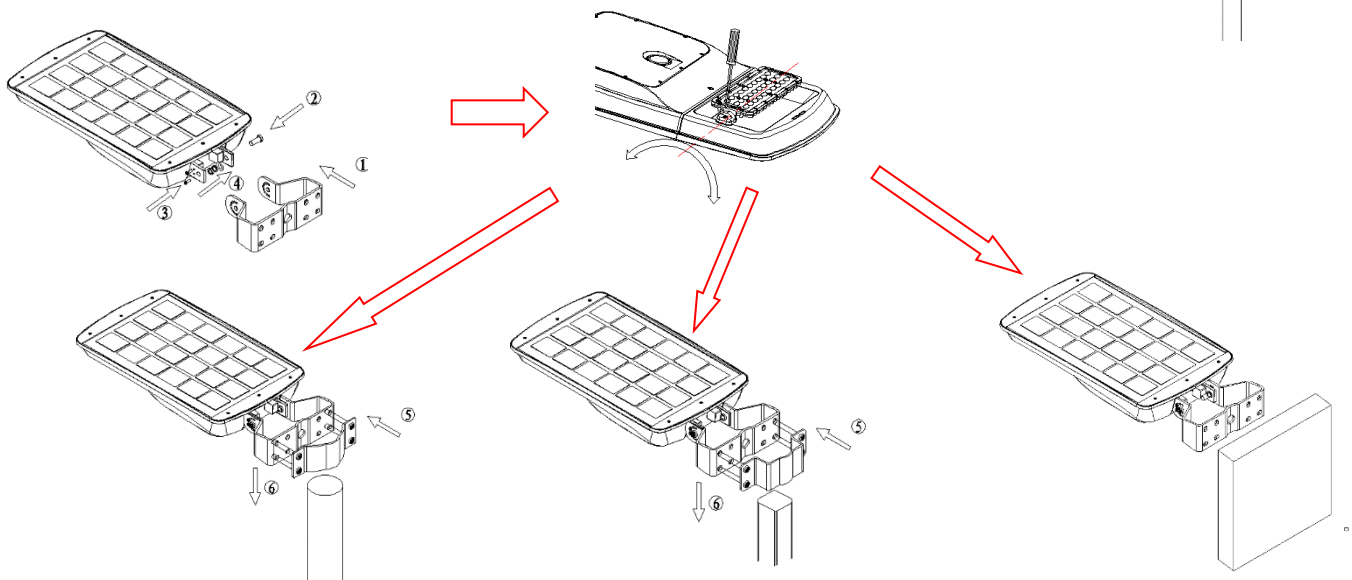
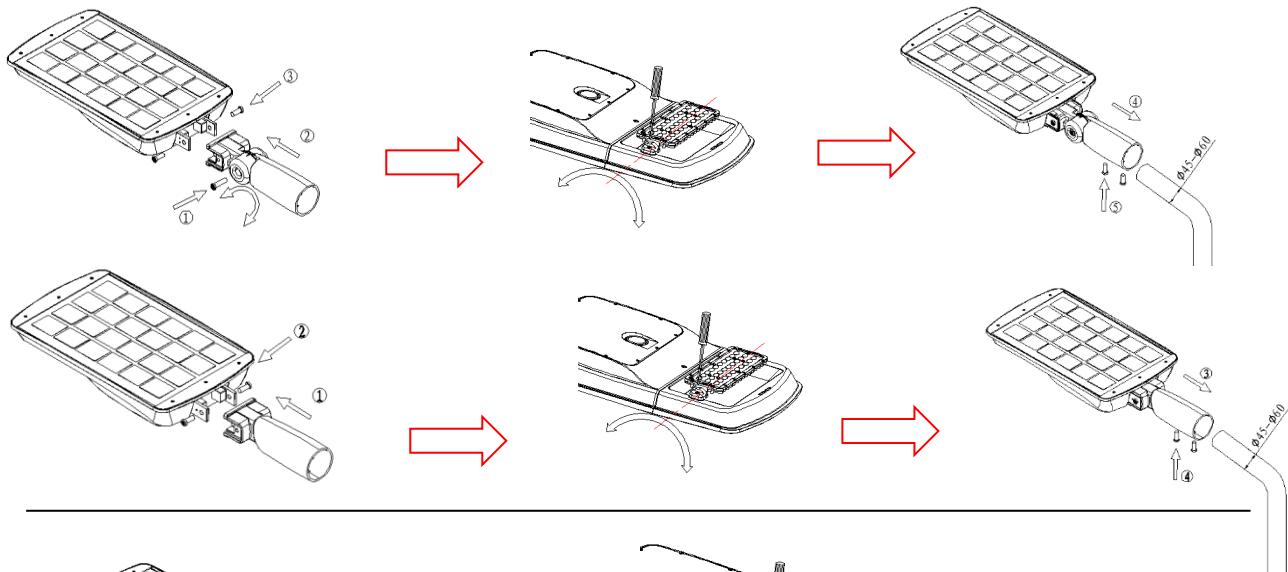

Adjustment steps

Select the right operating mode according to the usage needs and the local sunshine conditions

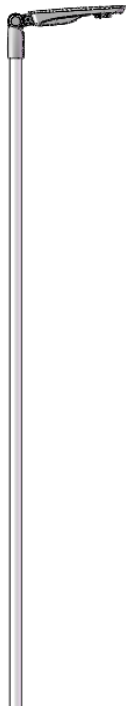

Replacement and Maintenance operations:

In case of battery failure or end of life, loosen the screws on the battery cover, disconnect the wire connectors, replace the whole battery cover kit (including smart control system, battery, cover) , connect the wires and tighten screws.

