

# Pro370-SERIES

with QuickTree® Technology

# Liberty Pumps®

A Family and Employee Owned Company

## The most advanced residential sewage package available

### Features

- Separate access cover
- QuickTree® float switch system allows easy removal of float switches without pulling the pump
- Large 41-gallon capacity
- Anti-flotation collar
- Molded torque stops
- Integrally-molded handles
- Unique integrated cord seal technology
- Integral rubber cover seals

### Shipped with Clear Construction Cover



Clear disposable cover protects the system during masonry work and rough-in



Patent: See  
[www.LibertyPumps.com/patents](http://www.LibertyPumps.com/patents)

# Pro370

QuickTree® Technology



innovate. evolve.

# Pro370-Series

## Features

- QuickTree® system allows easy access and removal of float switches without disturbing pump or plumbing
- Integral rubber seals permanently attached to cover
- Unique cord seal technology
- Inspection/access cover
- Larger basin – 40% more capacity than standard 18" X 30" basins – decreases float switch cycles, improves pump life
- Integrally-molded torque stops secure pump in its proper position
- Integrally-molded anti-flotation collar
- Integrally-molded handles to ease transportation and installation
- Durable polyethylene construction with radial ribs for added strength
- Completely assembled
- Available with any Liberty Pumps 2" solids handling sewage pumps

## QuickTree® Technology



## Dimensional Data

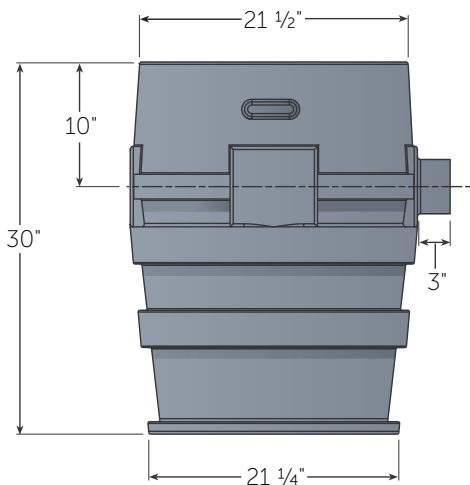

## Models: 2" Discharge Systems

MODEL	HP	VOLTS	PHASE	DISCHARGE	WEIGHT
P372LE41	4/10	115	1	2"	60 lbs
P372LE51	1/2	115	1	2"	64 lbs
P372LE52	1/2	208-230	1	2"	63 lbs
P372LE71	3/4	115	1	2"	83 lbs
P372LE72	3/4	208-230	1	2"	83 lbs
P372LE102*	1	208-230	1	2"	86 lbs
P372LEH102*	1	208-230	1	2"	86 lbs

For 3" discharge systems, change model number from "372" to "373."  
Example: P373LE41

See specific LE-Series literature for complete pump performance and specifications.  
\* High head applications only. Consult factory for proper pump sizing.

# Pro370-Series 21"x30" - 41 Gallons

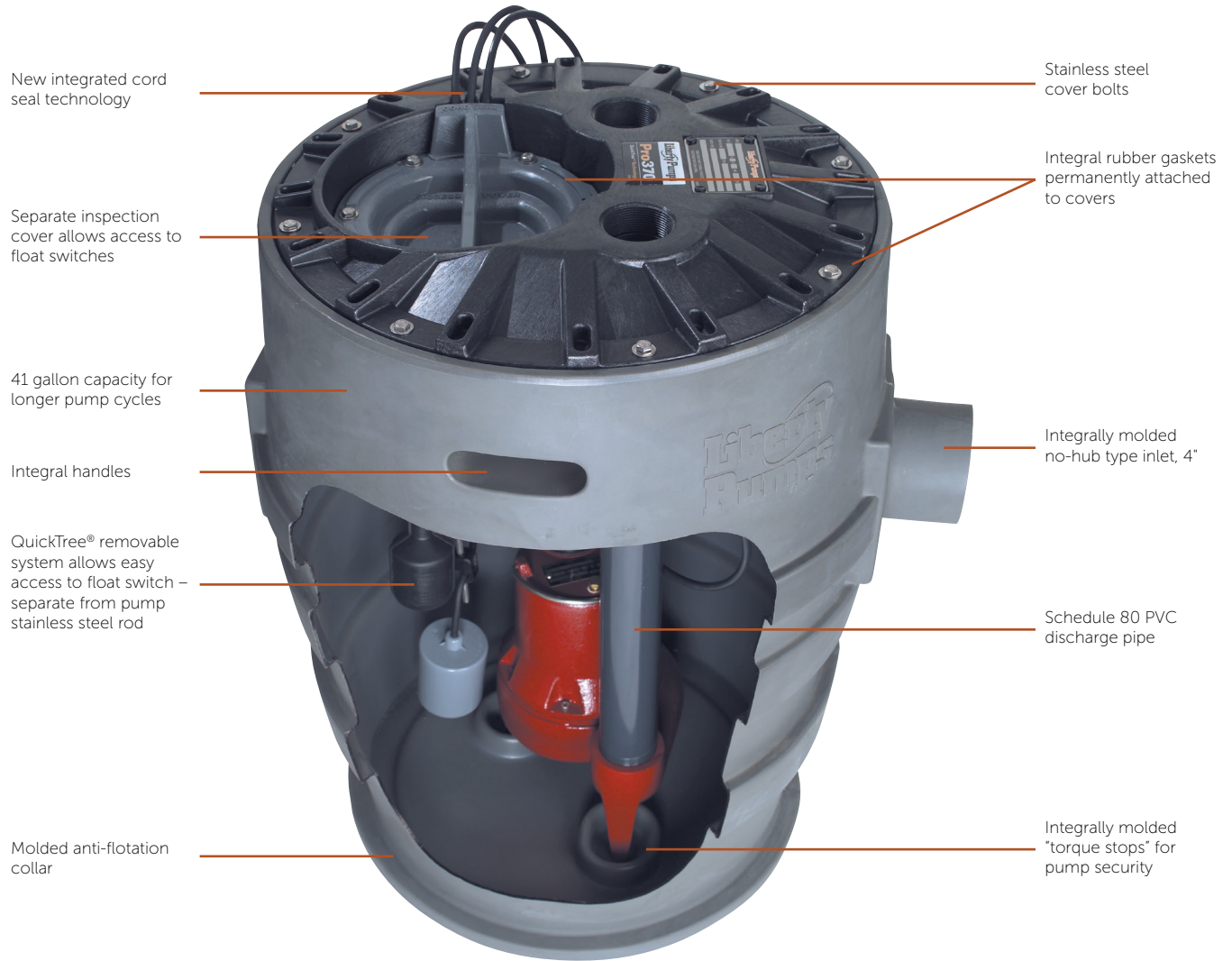

New integrated cord seal technology

Stainless steel cover bolts

Separate inspection cover allows access to float switches

Integral rubber gaskets permanently attached to covers

41 gallon capacity for longer pump cycles

Integrally molded no-hub type inlet, 4"

Integral handles

QuickTree® removable system allows easy access to float switch – separate from pump stainless steel rod

Schedule 80 PVC discharge pipe

Molded anti-flotation collar

Integrally molded "torque stops" for pump security

Patent: See [www.LibertyPumps.com/patents](http://www.LibertyPumps.com/patents)

## P370XL Series - IAPMO Listed Basins

The **P370XL** systems are specifically designed to pass a 10' stack test and are IAPMO listed.

The **P370XL-Series** has all the same features as the standard P370 except for a 16 bolt cover.

To order, simply add "X" to any standard P370 system.

**Example:**  
**P372XLE41**



## QuickTree® Kit

### Installed your Pro370 empty?

Simply order a QuickTree® Kit and manual LE-Series pump.



QuickTree® Kit comes complete with stainless steel rod, pump float switch and clamps pre-mounted

Need to install a Liberty Pumps pump in an empty Pro370 basin? No problem! QuickTree® kits make adding a pump easy! Simply install a manual LE-Series pump and a matching QuickTree® kit. Kits include stainless steel float switch tree, pre-mounted pump float switch and additional clamp for an alarm float switch. Hang the QuickTree® from its holder underneath the access cover and you're ready to go.

MODEL	DESCRIPTION
QT370-115-10	QuickTree® for Pro370, 115V, 10' cord
QT370-115-25	QuickTree® for Pro370, 115V, 25' cord
QT370-230-10	QuickTree® for Pro370, 230V, 10' cord
QT370-230-25	QuickTree® for Pro370, 230V, 25' cord

# Pro370-Series

## Optional Access Riser

Fits Pro370 and Pro380-Series systems

**Riser allows burial of the Pro370 System up to a maximum depth of 18" below grade**

A convenient chamber for all your pump's electrical and piping connections – out of sight and below grade. Riser simply slides over the sealed 370 system. Cover is retained by 4 stainless steel bolts and features a twist-lock design with provision for padlock to deter unwanted entry.

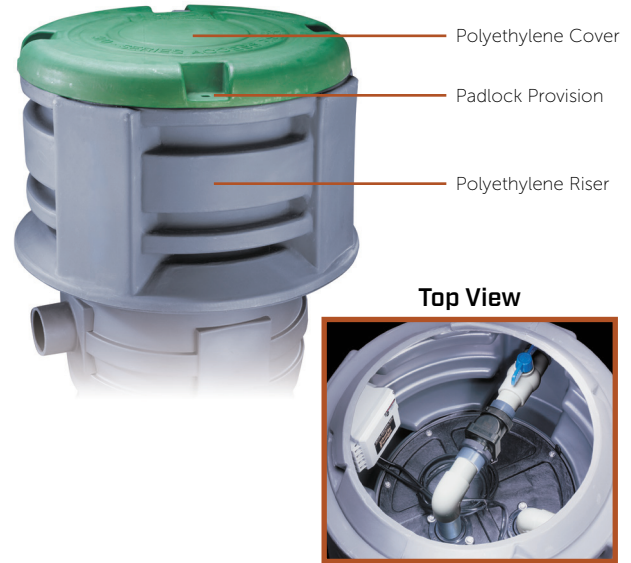

### Specifications

**Weight:** 28 lbs (Riser and Cover)

**Riser Height:** 18-3/4"

**Total Height with Cover:** 20-1/2"

**Diameter:** 32"

MODEL	DESCRIPTION
AR18	Access Riser
AC18	Access Riser Cover (Environmental Green)
ARC18	Kit, Access Riser with Cover
ARCKIT115	Kit, Access Riser with Cover and 2" installation accessories - 115V
ARCKIT230	Kit, Access Riser with Cover and 2" installation accessories - 230V
IKIT2-115	Installation Kit 2", 115V
IKIT2-230	Installation Kit 2", 230V

Liberty Pumps installation kits provide all the components for a professional installation inside the riser. Kit includes: JB-Series wiring box and hardware, check valve with a disconnect union feature, coupling and elbows (PVC piping not included). Kits available in 2" discharge and vent size only.

## Pro370-Series Alarmed System

Now have the assurance of early warning in the event of a high-level condition with an alarm option installed from the factory! We do the work for you by mounting the alarm float switch in the basin at its proper level – no need to even open the cover! Simply mount the alarm panel in its desired location, supply power and connect the alarm float switch leads! Offered with four different alarm options for indoor, outdoor, and wireless-enabled applications.

**NEW!**  
  
**NightEye®**  
 Wireless Enabled Alarm  
**AVAILABLE**

ALM-2-EYE

Patent: See  
[www.LibertyPumps.com/patents](http://www.LibertyPumps.com/patents)



**FREE app  
 download**



### How to Order

ALARM MODEL	DESCRIPTION	FLOAT SWITCH CORD	ADD SUFFIX	ORDER EXAMPLE
ALM-2	Standard indoor alarm	20'	/A2	P372LE41/A2
ALM-2-1	Standard indoor alarm	10'	/A21	P372LE41/A21
ALM-2-EYE	NightEye® wireless enabled	20'	/A2-EYE	P372LE41/A2-EYE
ALM-2W	Standard outdoor rated	20'	/A2W	P372LE41/A2W

Alarm float switch is pre-set at proper level in basin. Alarm panel packaged with unit. See alarm literature sheet for complete alarm specifications.

Specifications subject to change without notice.

Copyright © Liberty Pumps, Inc. 2019 All rights reserved. LLIT000700-R08/19

Liberty Pumps - 7000 Apple Tree Avenue - Bergen, New York 14416  
 Phone 800-543-2550 - Fax 585-494-1839 - [www.LibertyPumps.com](http://www.LibertyPumps.com)