

### Features

- Kohler plumbing products mean beautiful form as much as reliable function.
- Wall-mount.
- Space-saving drinking fountains are designed for easy maintenance and cleaning.

### Recommended Products/Accessories

- K-23726 Drain treatment
- K-23725 Cast iron cleaner

### Included Components

Additional Components:

- Bottom access plat assembly
- Hanger accessory pack
- Side access plate assembly
- Supply fitting sub-assembly
- Supply stop sub-assembly
- Trap with strainer
- Vitreous Fountain



### Codes/Standards

- ASME A112.19.2/CSA B45.1
- NSF/ANSI 61
- NSF/ANSI 372
- All applicable US Federal and State material regulations



### KOHLER® One-Year Limited Warranty

See website for detailed warranty information.

### Available Colors/Finishes

*Color tiles intended for reference only.*

Color	Code	Description
-------	------	-------------

	0	White
	47	Almond

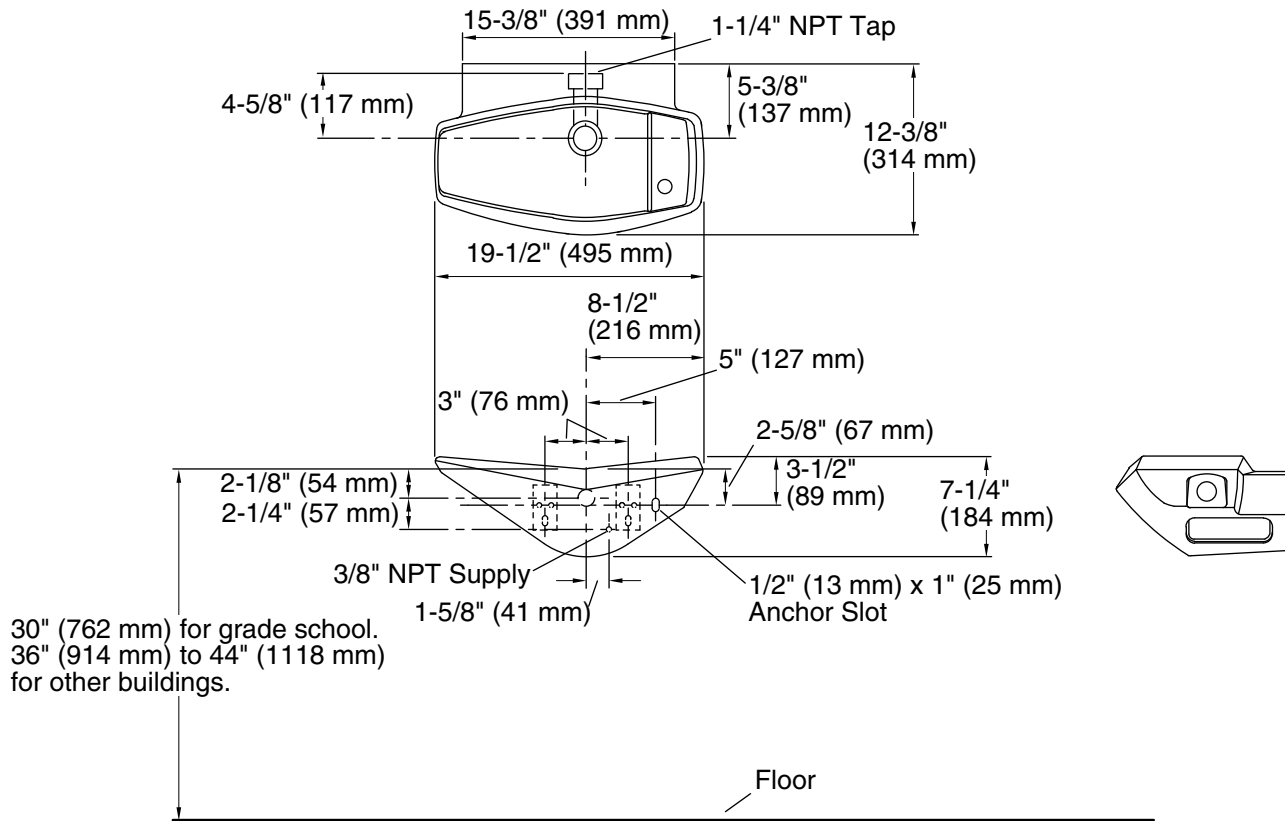

### Technical Information

All product dimensions are nominal.

Installation: Wall-mount

### Notes

Install this product according to the installation instructions.