

Electraflash® Strobe Warning Light

Model 141ST



DESIGNED FOR INDUSTRIAL OR VEHICULAR USE

- Available in 12VDC, 24VDC, and 120VAC
- Four dome colors
- 4,000 hour strobe tube
- Surface mount or integrated 1/2-inch NPT pipe mount
- Indoor/outdoor use
- Type 3R enclosure
- UL Listed and CSA Certified

Federal Signal's Electraflash® 141ST is an economical strobe light designed for a variety of industrial uses. This compact warning light is less than six inches tall and six inches in diameter. Models are available in four fresnel dome colors, including Amber, Blue, Green and Red. All models are UL Listed for indoor/outdoor use and the 120VAC models are CSA Certified.

The Model 141ST is available in 12VDC, 24VDC and 120VAC, and includes a removable strobe mechanism. The 12VDC and 24VDC units have three holes for flat surface mounting. The 120VAC version come ready to mount on a 1/2-inch NPT pipe. Optional wall mounting brackets (Model LWMB2) or corner mounting brackets (Model LCMB2) are available for the 120VAC unit.

Federal Signal's Electraflash strobe lights are designed for both indoor and outdoor industrial environments. The unit's convenient size and intense light output make it ideal for use on maintenance vehicles, fork lifts, and other material handling equipment, effectively alerting hazardous conditions or dangerous areas.

Federal Signal's Electraflash strobe warning light is an affordable visual signal which is ideally suited for light duty applications.

Model	Voltage	Operating Current	Flash Rate/ Minute	Candela Peak ¹	Mount
141ST-012 *	12VDC	0.18 amps	80	100,000	Surface
141ST-024 *	24VDC	0.08 amps	80	100,000	Surface
141ST-120 *	120VAC 50/60HZ	0.06 amps	80	100,000	1/2" NPT Pipe

* Indicates color: (A) Amber, (B) Blue, (G) Green or (R) Red

¹ Peak candela is the maximum light intensity generated by a flashing light during its light pulse



ELECTRAFLASH® STROBE LIGHT (141ST)

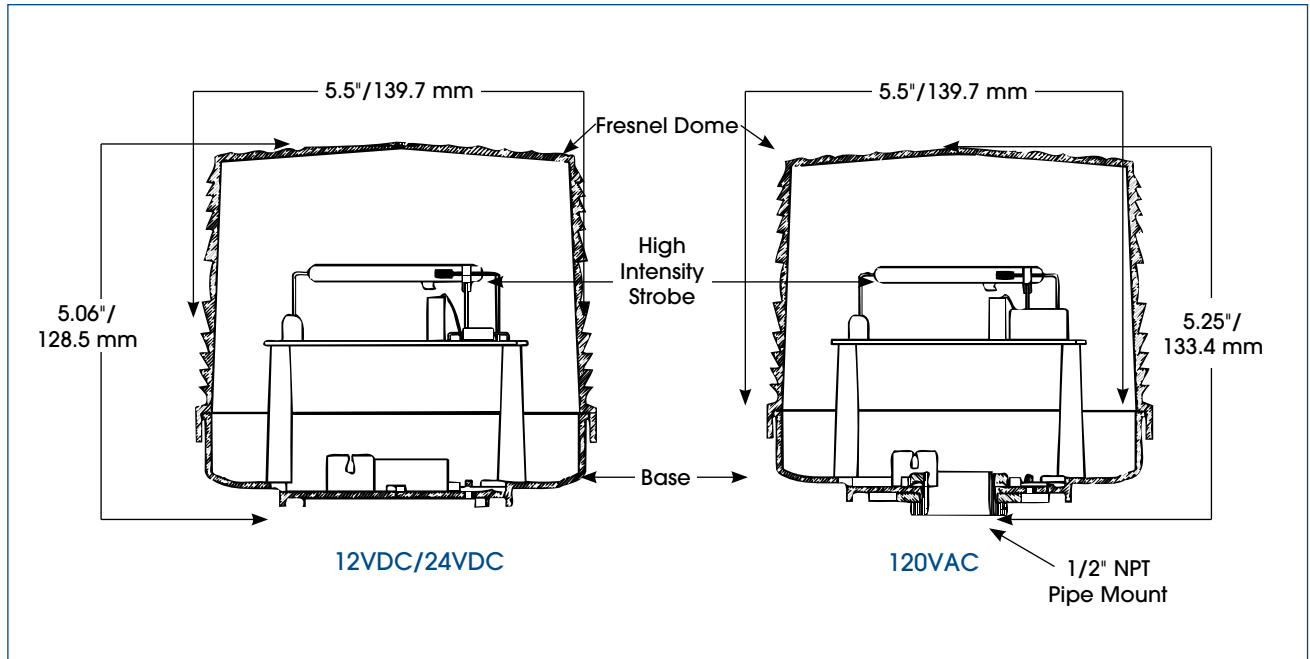

SPECIFICATIONS

Lamp Life:	4,000 Hours	4,000 Hours
Light Source:	Strobe tube	Strobe tube
Operating Temperature:	-31°F to 150°F	-35°C to 66°C
Net Weight:		
DC Models	0.8 lbs.	0.4 kg
AC Models	0.9 lbs.	0.4 kg
Shipping Weight:		
DC Models	1.3 lbs.	0.5 kg
AC Models	1.4 lbs.	0.5 kg
Height:		
DC Models	5.06"	128.5 mm
AC Models	5.25"	133.4 mm
Diameter:		
DC Models	5.5"	139.7 mm
AC Models	5.5"	139.7 mm

HOW TO ORDER

- Specify model, voltage and color
- Optional Accessories (120VAC only):
 - Corner Bracket (LCMB2)
 - Wall Bracket (LWMB2)
 - Hazardous Location Mounting Bracket (LHWB)

REPLACEMENT PARTS

<i>Description</i>	<i>Part Number</i>
Dome, Amber	K8263079A
Dome, Blue	K8263079A-01
Dome, Green	K8263079A-03
Dome, Red	K8263079A-02
Strobe Tube	K149128A