

HUBBELL HOSE REELS

Cat. Nos. HBLHR3825I, HBLHR2550I, HBLHR3850I, HBLHR3825, HBLHR3850

INSTALLATION INSTRUCTIONS

GENERAL INFORMATION

NOTICE: For installation by a qualified individual in accordance with national and local safety codes and the following instructions.

CAUTION: RISK OF EXPLOSION. Not for use with oxygen. Do not convert air hose to oxygen service. Compressed air hoses are often contaminated with an oil coating, which can react explosively when oxygen is introduced.

CAUTION: RISK OF PHYSICAL INJURY OR DEATH. Disconnect and purge all system pressure before installing or uninstalling reel.

Check that the supplied system pressure does not exceed the maximum working pressure rating of the reel (300 psi).

Ensure that reel is properly installed before connecting system pressure.

A high-tension spring assembly is contained within the reel. Exercise extreme caution when unwinding or rewinding hose. If reel ceases to unwind or rewind, remove system pressure immediately. Do not pull or jerk on the hose.

Inspect the hose for rupture or damage before each use. Pull hose from reel by grasping the hose, not the attached tool.

If a leak should occur in the hose or reel, remove system pressure immediately.

DIMENSIONAL DATA

	A	B	C	D	E	INLET
HBLHR3825I	12.88	12.63	8.00	2.50	5.38	3/8 NPTF
HBLHR3825	12.88	12.63	8.00	2.50	5.38	3/8 NPTF
HBLHR2550I	14.50	13.75	9.75	2.50	7.00	3/8 NPTF
HBLHR3850I	17.50	16.50	9.75	2.50	6.00	3/8 NPTF
HBLHB3850	17.50	16.50	9.75	2.50	6.00	3/8 NPTF

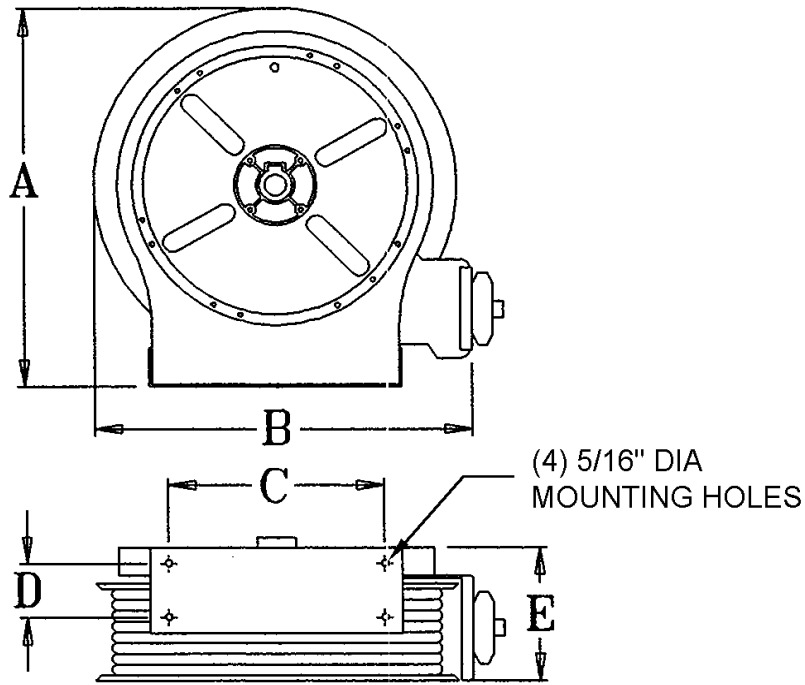

FIG. 1



MOUNTING

NOTICE: Maximum installation height is 16 feet (4.87 m). Do not exceed this distance.

1. Unpack and inspect reel for shipping damage. Turn by hand to check for smooth operation.
2. Configure reel for top, side or bottom hose dispensing by removing the screws and nuts (item 1, Fig. 2) from the guide arm bracket (item 2) and re-positioning the bracket to the desired location. Secure the bracket in the new location with the screws and nuts provided in that location. Re-insert and securely tighten the original screws and nuts in their original location.

CAUTION: RISK OF INJURY. Spring winding mechanism is under tension. Use extreme caution.

3. Position the reel base to floor, wall or ceiling. Secure into place using four (customer supplied) fasteners (item 3, Fig. 2). **CAUTION: Reel is heavy – mount securely! Recommended mounting hardware: 1/4" X 1-1/2" (6mm X 40mm) lag screws with washers. If mounting over head, provide safety chain between reel base and mounting surface to prevent accidental reel drop.** For installation on a wood, drywall or stucco surface, mount the reel to a 2" (51 mm) thick piece of lumber that has been fastened into studs. For installation on a brick, cement, cinder block or other hard surface, insert aluminum anchors into the hard mounting surface before mounting the reel.
4. Connect a (customer supplied) flexible hose supply line to inlet. Do not use rigid plumbing. Apply pipe thread sealant to threads and do not overtighten the connection. Torque should not exceed 70 ft-lbs.

ADJUSTMENTS

SPRING TENSION

If necessary, adjust spring tension on reel by adding or removing wraps of hose from spool, one wrap at a time, until desired tension is obtained. Add wraps to increase tension, remove wraps to decrease tension.

NOTICE: When adding wraps of hose, be careful not to exceed the winding mechanism's spring capacity. Add just enough wraps of hose to achieve the desired tension. Damage to the winding mechanism will result if spring is over-tensioned. Exercise extreme caution.

HOSE BUMPER

Adjust hose bumper (item 4, Fig. 2) by loosening clamping screws. Slide bumper into desired position and tighten the screws.

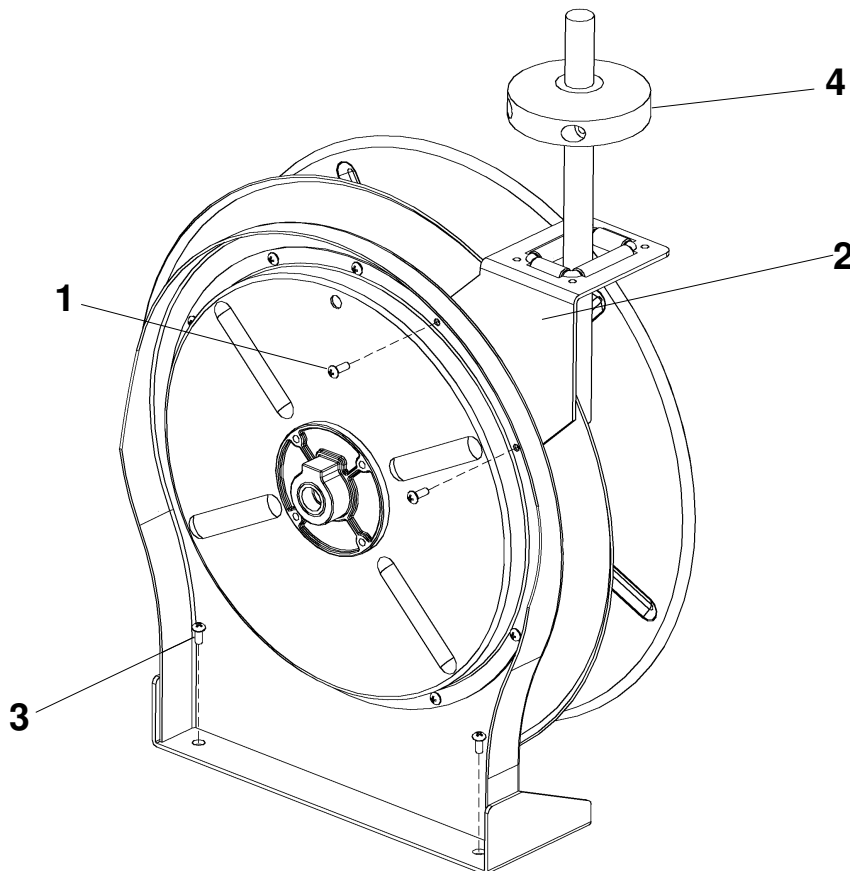

FIG. 2