

CONTINUOUS HINGE WITH CLAMPS, TYPE 12

INDUSTRY STANDARDS

UL 50, 50E Listed; Type 12, 13; File No. E27567
 cUL Listed per CSA C22.2 No 94; Type 12, 13; File No. E27567

NEMA/EEMAC Type 12, 13
 CSA File No. 42184: Type 12
 IEC 60529, IP65
 Meets NEMA Type 3RX requirements

APPLICATION

Lightweight enclosures protect components and controls in indoor applications.

SPECIFICATIONS

- Type 5052 H-32 aluminum .080-in. (2-mm) thick
- Seams continuously welded and ground smooth
- Stainless steel screws and clamps secure cover
- Cover removed by pulling stainless steel continuous hinge pin
- Oil-resistant gasket
- Weldnuts furnished for mounting optional panels and terminal block kits

FINISH

Enclosures are unpainted. Cover and sides of body have smooth brushed finish.

ACCESSORIES

See also *Accessories*.
 Industrial Corrosion Inhibitors
 Fast-Operating Clamp-Cover Junction Box Clamp
 Lock Kit for Clamp Cover Junction Boxes
 Panels for Junction Boxes
 Junction Box and Wall-Mount Enclosure Swing-Out Panel Kit

MODIFICATION AND CUSTOMIZATION

Hoffman excels at modifying and customizing products to your specifications. Contact your local Hoffman sales office or distributor for complete information.

BULLETIN: A51A

Standard Product

Catalog Number	AxBxC in./mm	Aluminum Panel	Steel Panel	Conductive Panel	Panel Size D x E in./mm	Mounting G x H in./mm	Overall L x W in./mm	F in./mm	J in./mm	P in./mm	T in./mm	V in./mm	Y in./mm
A606CHAL	6.00 x 6.00 x 4.00 152 x 152 x 102	A6P6AL	A6P6	A6P6G	4.88 x 4.88 124 x 124	6.75 x 4.00 171 x 102	7.50 x 6.94 191 x 176	3.50 89	3.56 90	2.38 60	5.00 127	0.31 8	0.56 14
A8064CHAL	8.00 x 6.00 x 4.00 203 x 152 x 102	A8P6AL	A8P6	A8P6G	6.75 x 4.88 171 x 124	8.75 x 4.00 222 x 102	9.50 x 6.94 241 x 176	3.50 89	3.56 90	3.38 86	5.00 127	0.25 6	0.62 16
A1008CHAL	10.00 x 8.00 x 4.00 254 x 203 x 102	A10P8AL	A10P8	A10P8G	8.75 x 6.88 222 x 175	10.75 x 6.00 273 x 152	11.50 x 8.94 292 x 227	3.50 89	3.56 90	1.50 38	7.00 178	0.25 6	0.62 16
A12106CHAL	12.00 x 10.00 x 6.00 305 x 254 x 152	A12P10AL	A12P10	A12P10G	10.75 x 8.88 273 x 225	12.75 x 8.00 324 x 203	13.50 x 10.94 343 x 278	5.50 140	5.56 141	2.00 51	9.00 229	0.25 6	0.62 16
A1412CHAL	14.00 x 12.00 x 6.00 356 x 305 x 152	A14P12AL	A14P12	A14P12G	12.75 x 10.88 324 x 276	14.75 x 10.00 375 x 254	15.50 x 12.94 394 x 329	5.50 140	5.56 141	3.00 76	11.00 279	0.25 6	0.62 16
A1614CHAL	16.00 x 14.00 x 6.00 406 x 356 x 152	A16P14AL	A16P14	A16P14G	14.75 x 12.88 375 x 327	16.75 x 12.00 425 x 305	17.50 x 14.94 445 x 379	5.50 140	5.56 141	1.50 38	13.00 330	0.25 6	0.62 16

Purchase panels separately. Optional stainless steel, composite and aluminum panels are also available for most sizes.

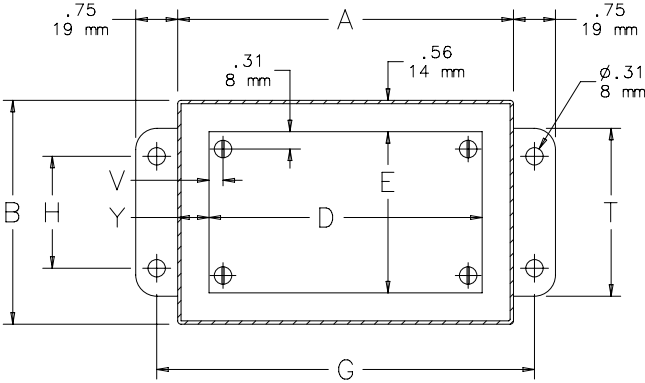
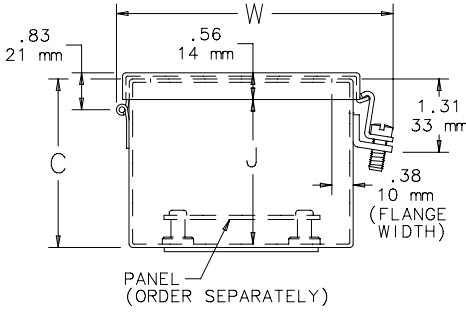
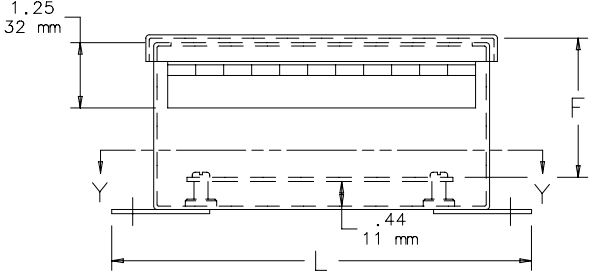

SECTION Y-Y

- NOTES: 1. Aluminum panels are .080 in. (2mm) thick.
 2. Steel panels are 14 gauge.
 3. Stainless steel panel screws are #10-32 pan head.

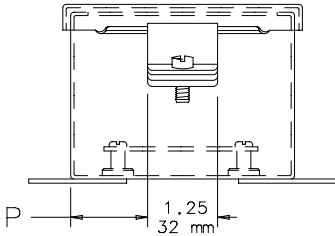

View showing clamp end of box when one clamp is used.

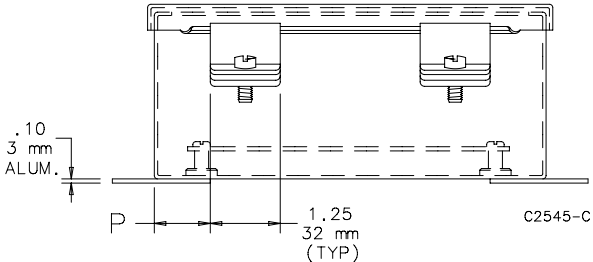

View showing clamp end of box when two clamps are used. When A > 8.00 (203 mm), use two clamps.