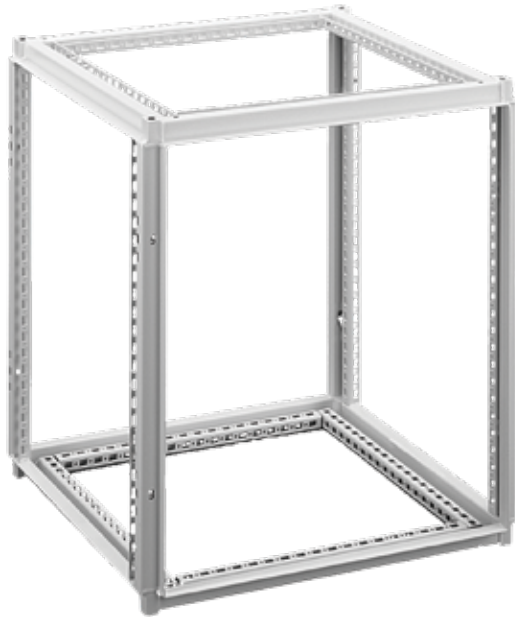

FRAME BASE FOR SLOPED-FRONT HMI

Frames are 700-mm tall and sized to allow installation of sloped fronts on top and other equipment below, thus configuring a console suitable for sitting or standing operators. The frame provides joining capability and means for rack, subpanel or grid-system mounting of any type of equipment inside. Frames are available 600-, 800- and 1200-mm wide to fit 600-, 800- and 1200-mm wide sloped fronts. All frames have two latch/hinge blocks per vertical unit. Requires appropriate frame joining kit. Finish is RAL 7035 textured light-gray polyester powder paint. See Modular Enclosure Systems for additional frame sizes.

A 1200-mm wide sloped front will accommodate two 600-mm wide frames only if frame joining kit PJ2FW7 is used.

When used in conjunction with sloped fronts, PROLINE frames provide an excellent solution for configuring and joining multiple consoles into a large control installation. Joining enclosures frame-to-frame provides uninterrupted space for wiring and additional equipment. The sloped front and frame can also be used individually as a stand-alone console.

The modular design of the frames provides maximum mounting flexibility. Choose from a variety of door and cover options. A full range of accessories is also available.

BULLETIN: P20, P20EM

Catalog Number	AxBxC mm/in.	Nominal Frame Size	Maximum Subpanel Size mm/in.	Maximum Rack Mounting Space
PF766	680 x 599 x 588 26.77 x 23.58 x 23.15	700 x 600 x 600	585 x 530 23.03 x 20.87	13U
PF786	700 x 800 x 600 27.56 x 31.50 x 23.62	700 x 800 x 600	585 x 530 23.03 x 20.87	13U
PF786HF	700 x 800 x 600 27.56 x 31.50 x 23.62	700 x 800 x 600	585 x 530 23.03 x 20.87	13U
PF7126	700 x 1200 x 600 27.56 x 47.24 x 23.62	700 x 1200 x 600	585 x 1130 23.03 x 44.49	13U x 2

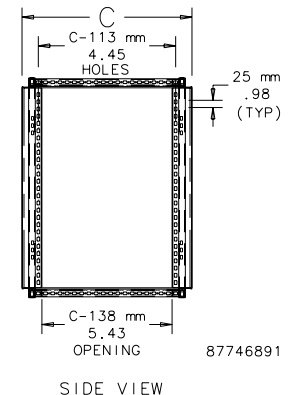
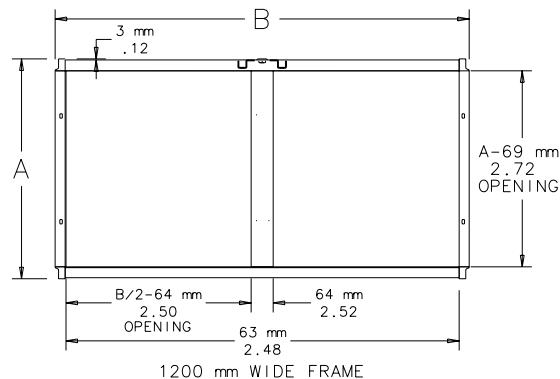
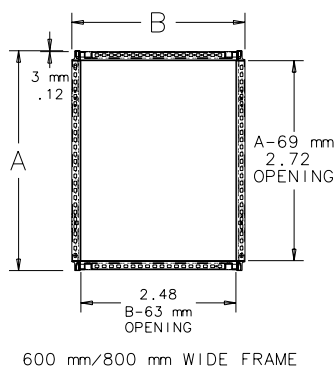
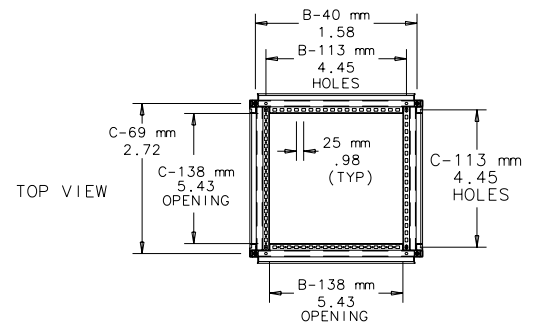

When used in conjunction with sloped tops, PROLINE frames provide an excellent solution for configuring and joining multiple consoles into a large control installation. Joining enclosures frame-to-frame provides uninterrupted space for wiring and additional equipment. The sloped top and frame can also be used individually as a stand-alone console. The modular design of the frames provides maximum mounting flexibility. Choose from a variety of door and cover options. A full range of accessories is also available. See the Modular Enclosure Systems chapter for additional external and internal accessories that fit 700mm-tall frames.

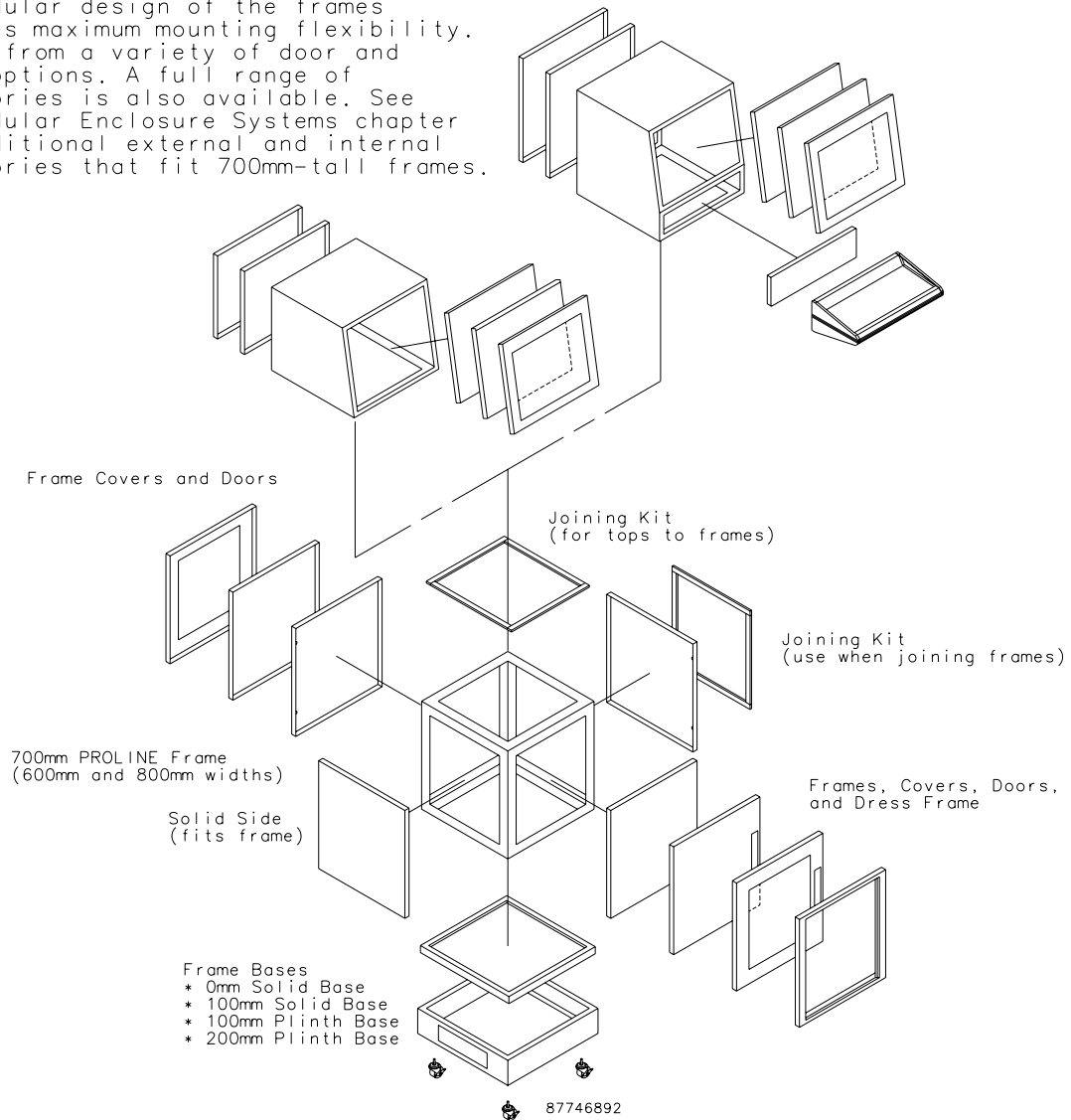

ERGONOMIC DESIGN

To order the HMI enclosure and accessories that provide an optimum ergonomic design for your operators, we've developed the Ergonomics Reference Guide below. By knowing the height of each piece that is part of the Human-Machine Interface Enclosure System, you can design a workstation that provides optimum effectiveness and safety. The adjustable keyboard and swivel/tilt accessories provide additional ergonomic solutions.

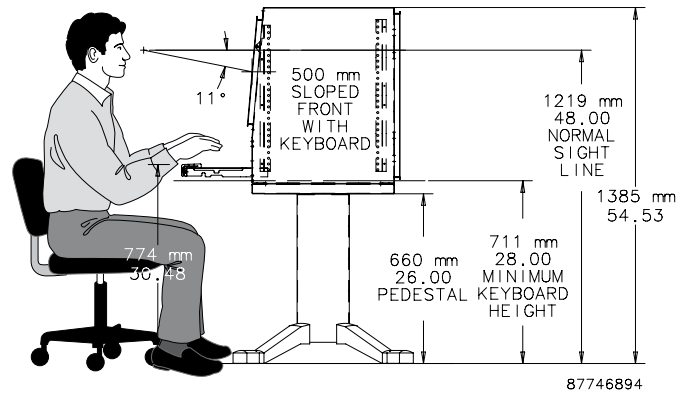
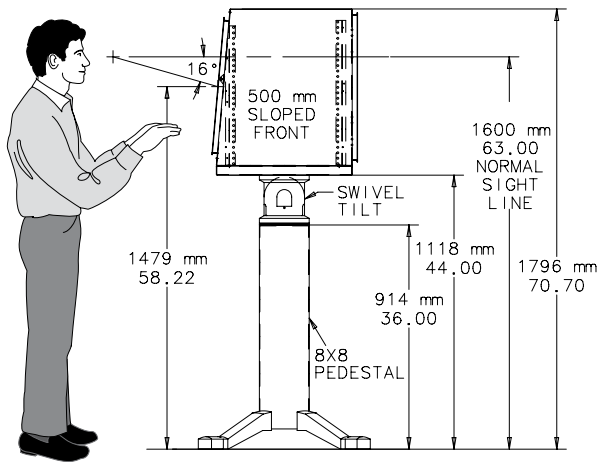
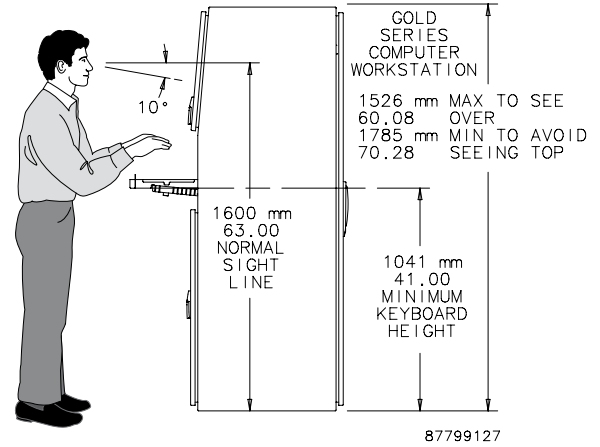
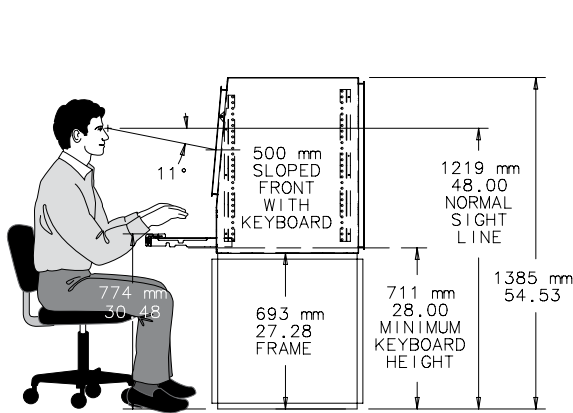

Notes