

Russellstoll® Type J Plugs, Receptacles and Connectors

Application

J-Line devices can be found in a broad range of industrial and marine applications. These devices may be specified for virtually any use, such as: data processing, portable heavy equipment, industry, shipyards and underfloor applications.

J-Line Series devices are available in 30, 60, 100 and 200 amp at 600 VAC, 250 VDC Maximum (Also available upon request in 150 and 270 amp types for disconnect use only). The product is offered from 2-pole, 3-wire through 4-pole, 4-wire.

J-Line Series devices are designed for indoor or outdoor use. When properly maintained and installed, J-Line devices will provide reliable operation in wet, damp, dirty and corrosive industrial environments.

Catalog Numbering System for "J" Line plugs, receptacles and connectors

Use the following system for identifying your particular device.

<u>1</u>	<u>2</u>	<u>3</u>	<u>4</u>	<u>5</u>	<u>6</u>	<u>7</u>	<u>8</u>	<u>9</u>
J	P	F	A	X	X	X	F	R
	R	S	B				H	
			E				K	
			H				D	
			R				LK	
			X					

- (1) 'J' Line Device
- (2) Plug or Receptacle
- (3) Flap or Screw Cover (Screw Collar for Plugs)
- (4) 20° Angle Adapter
30° Angle Adapter (B)
20° Angle Outlet Enclosure
20° Angle Horizontal Box Adapter
Right Angle Adapter
Panel Mounting (X)
- (5) Amperage
- (6) Wires
- (7) Poles
- (8) Polarization Designation
- (9) Reverse Service

Preparation

1. Recommended Tools

Cable Cutters	Pipe Wrenches
Wire Strippers	Torque Wrench
Allen Wrenches	Ohmmeter
Screw Drivers	

2. Select maximum allowable wire and cable size for amperage rating from Table 1. Size and type of flexible cords and cables must be in compliance with N.E.C. Article 400.

Table 1

J-Line Ampere Rating	Cable Size AWG
30	#8 flexible #6 7 strand
60	#4 flexible #4 7 strand
100	#1 flexible #1/0 19 strand
150	#1/0 flexible #2/0 19 strand
200	#4/0 flexible #4/0 19 strand
270	#4/0 flexible 250 MCM 37 strand

3. Establish a wiring pattern so that the same colored wire is put into the same numbered contacts on all plugs and receptacles in that system.
J-Line devices are polarized so the plug will enter receptacle or connector only one way. Also, contact chambers in insulating bodies are identified by number insuring proper polarity of conductors through mating plugs and receptacles/connectors.

⚠ WARNING ⚠
ELECTRICAL HAZARD!
BE SURE POWER IS OFF!

⚠ WARNING ⚠
Equipment connected to circuits having different voltage, frequency or current on the same premises must not be interchangeable.

⚠ CAUTION ⚠
Use only copper wire with box mounted outlet or inlet.

Installation

Plug installation - page 2, step 4
Receptacle installation page 3, step 4

PLUG INSTALLATION

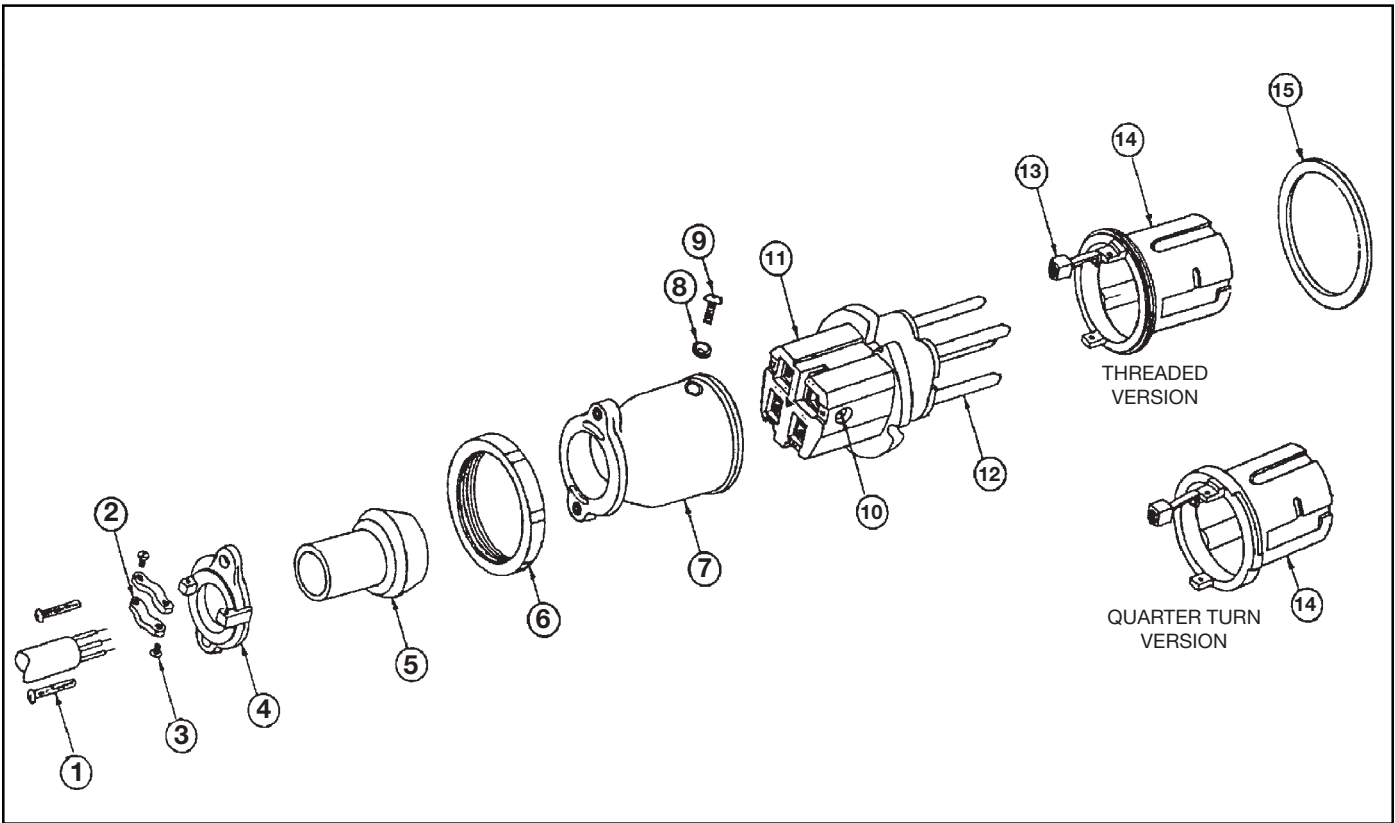

4. **Turn power off.**
5. Remove screw #9 and washer #8 from handle #7.
NOTE: Do not remove collar nut #6.
6. Remove plug handle #7 from plug sleeve #14 by turning handle counter clockwise.
7. Remove clamp-holder assembly parts #1, 2, 3, 4 from plastic bag.
8. Position cable bushing #5 in end of plug handle #7.
9. Place clamp holder #4 over bushing #5 and secure to plug handle #7 with screws #1.
10. Slide handle #7 over equipment cable.
11. Strip cable jacket and conductors per dimension shown in Fig. 1 or refer to strip gage on back of interior #11.

12. Loosen pressure screws #10 in pins #12.
13. Insert stripped end of each conductor in proper pin terminal #12.
14. Tighten pressure screws #10 to torque values indicated in Fig. 2.

J-Line Ampere Rating		30	60	100 & 150	200 & 270
Conductor Size		#14-10 #8 #6	#14-10 #8 #6-4	#4-6 #3-2/0	#2-1 1/0-2/0 3/0-250
Pressure Screw Torque (in lbs)	Line/Neutral Conductor	35 40 45	35 40 45	45 50	200 200 200
	Ground Conductor	35 40 45	35 40 45	45 50	150 180 250

Fig. 2

J-Line Ampere Rating	Dimension	
	A	B
30	1 - 1/8	7/16
60	2-7/8	9/16
100	3	11/16
150	3	1-1/16
200	5-13/16	1-1/16
270	5-13/16	1-1/16

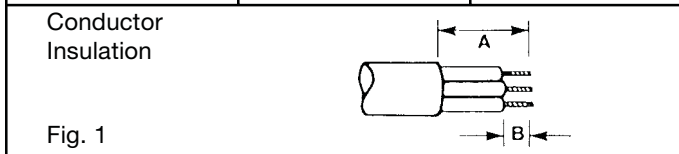
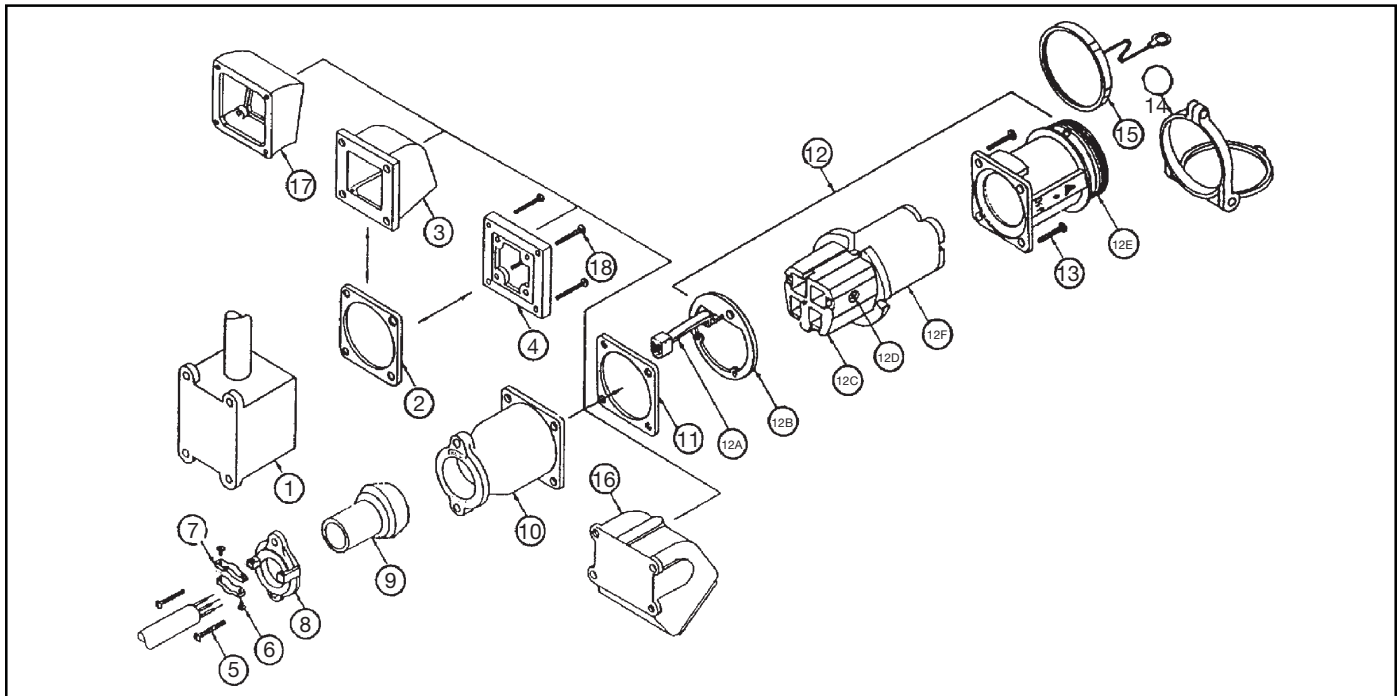

Fig. 1

15. Attach ground wire to lug #13 if furnished with plug.
16. Reassemble plug handle #7 to plug sleeve #14 by turning handle clockwise, lining up the hole in the handle with the hole in the plug sleeve.
17. Slide collar nut #6 to front of plug handle #7 and assemble screw #9 and washer #8 in the handle.
18. Assemble clamps #2 to clamp holder #4 by inserting 2 screws #3 through holes in holder. Tighten screws until clamps firmly grip cable.
19. Make sure gasket #15 is on plug sleeve #14.

RECEPTACLE & CONNECTOR INSTALLATION



4. Turn power off.

5. Prepare mounting location for your type of device using one of the following methods:

- Method A – Straight or angle receptacle with junction box
- Method B – Connector
- Method C – Receptacle with angle enclosure or panel mounting adapter.

METHOD A

Securely fasten junction box #1. Install service supply. Pull cable into junction box leaving enough cable to connect to receptacle. Slide adapter #3 or #4 and gasket #2 over supply cable and fasten to junction box with screws #18.

METHOD B

Remove clamp-holder assembly parts #5, #6, #7 and #8 from plastic bag. Position cable bushing #9 in end of connector handle #10. Place clamp holder #8 over bushing #9 and secure to connector handle #10 with screws #5. Slide connector handle #10 and receptacle gasket #11 over cable.

METHOD C

Securely fasten enclosure #16 or panel mounting adapter #17 to #12. Install service supply. Pull cable into enclosure leaving enough cable to connect to receptacle.

6. Strip cable jacket and conductor insulation to dimensions shown in Fig. 1 or refer to strip gauge on back of interior #12F.

7. Loosen pressure screws #12 D in contacts #12C. Insert stripped end of each conductor in the proper sleeve terminal #12C. Tighten pressure screws to torque values indicated in Fig. 2. Attach ground wire to lug #12A if furnished with device.

J-Line Ampere Rating		30	60	100 & 150	200 & 270
Conductor Size		#14-10 #8 #6	#14-10 #8 #6-4	#4-6 #3-2/0	#2-1 1/0-2/0 3/0-250
Pressure Screw Torque (in lbs)	Line/Neutral Conductor	35 40 45	35 40 45	45 50	200 200 200
	Ground Conductor	35 40 45	35 40 45	45 50	150 180 250

Fig. 2

8. Assemble receptacle using Method A with junction box, Method B for connector or Method C for angle enclosure and panel mounting adapter.

METHOD A

Assemble receptacle gasket #11 and receptacle #12 to adapter #3 or #4 with (4) screws #13.

METHOD B

Assemble gasket #11 and connector handle assembly #10 to receptacle #12 with (4) screws #13. Assemble clamps #7 to clamp holder #8 by inserting (2) screws #6 through holes in holder. Tighten screws until clamps firmly grip cable.

METHOD C

Assemble receptacle gasket #11 and receptacle #12 to angle enclosure #16 or panel mounting adapter #17 with 4 screws #13. Torque per table on sheet 4.

9. Assemble cover to receptacle. Watertight receptacles and connectors are furnished with a screw cap #15 which is assembled by removing one (1) of the four (4) screws #13 in the housing #12E and reassembling with the chain of the screw cap secured under the head of the screw.

Weatherproof receptacles and connectors are furnished with flap covers #14 and are assembled by holding the flap ring flush against shoulder of housing #12 and tightening set screws.

J-Line Ampere Rating	Dimension		Conductor Insulation
	A	B	
30	2-3/4	7/16	<p>Fig. 1</p>
60	3-1/2	9/16	
100	3-5/8	11/16	
150	3-5/8	11/16	
200	6-1/8	1-1/16	
270	6-1/8	1-1/16	

RECEPTACLE PANEL MOUNTING TO SHEET METAL ENCLOSURE TYPE 3R (JRF, JRFX & JRFB SERIES)

Sheet metal enclosures for mounting must be 14 gauge minimum and carry equivalent type rating of receptacle.

1. Turn power off.
2. Drill mounting holes in enclosure per figure and table below.
3. Strip cable jacket as directed in step 6, page 3.
4. Assemble conductors to receptacle as directed in step 7, page 3.

TO ENSURE COMPLIANCE TO NEC ARTICLE 250, MAKE SURE THAT THE RECEPTACLE GROUND WIRE IS PRESENT AND PROPERLY SECURED. A GROUND WIRE IS ALSO REQUIRED FROM THE RECEPTACLE TO THE ENCLOSURE GROUND.

5. Assemble receptacle gasket (#11) and receptacle (#12) to enclosure with four screws (#13), sealing washers, lock washers and nuts. The lock washers and nuts are to be on the inside of the enclosure. Orientate the receptacle so that the flap cap opens up (12 o'clock position).
6. Torque the screws (#13) per table below.

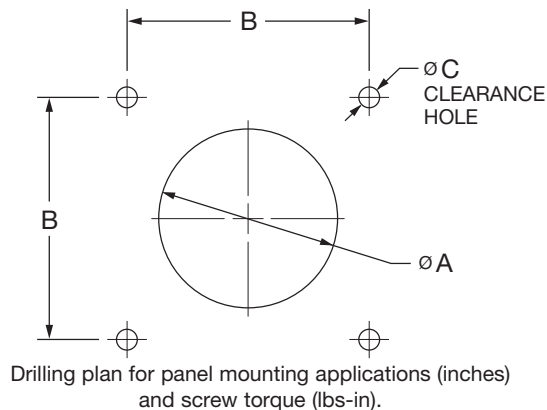

DEVICE	A	B	C	Torque
30A JRF & JRS SERIES	2.13	2.25	0.25	20
30A JRFFX & JRFX SERIES	2.75	2.55	0.28	20
60A JRF & JRS SERIES	2.75	2.55	0.28	35
60A JRFX & JRFX SERIES	3.25	3.36	0.26	35
100A JRF & JRS SERIES	3.25	3.36	0.26	35
100A JRFX & JRFX SERIES	3.50	3.63	0.26	35
200A JRF & JRS SERIES	4.75	4.88	0.34	35
200A JRFX & JRFX SERIES	5.13	5.25	0.34	35

Electrical Testing

Do not connect to power until the following electrical tests have been performed.

1. Make continuity checks of wiring with Ohmmeter to verify correct phasing and grounding connections.
2. Check insulation resistance to be sure system does not have any short circuits or unwanted grounds.

Connect all devices in the system, turn the power on and test the system.

Maintenance

Inspection of electrical equipment used in industrial and heavy use situations must be conducted regularly to ensure proper function and safety.

Check for the following during inspection:

1. Unsecured contact wire terminals
2. Cracked or broken housings
3. An unfastened or loose ground conductor
4. Deteriorated or misplaced gaskets
5. Loose or missing screws



WARNING



If any part of the plug, receptacle or connector appear to be missing or damaged, DISCONTINUE USE IMMEDIATELY. Replace with factory replacement parts only before continuing use.

WARRANTY: Thomas & Betts sells this product with the understanding that the user will perform all necessary tests to determine the suitability of this product for the user's intended application. Thomas & Betts warrants that this product will be free from defects in materials and workmanship for a period of two (2) years following the date of purchase. Upon prompt notification of any warranted defect, Thomas & Betts will, at its option, repair or replace the defective product or refund the purchase price. Proof of purchase is required. Misuse or unauthorized modification of the product voids all warranties.

Limitations and Exclusions: THE ABOVE WARRANTY IS THE SOLE WARRANTY CONCERNING THIS PRODUCT, AND IS IN LIEU OF ALL OTHER WARRANTIES EXPRESS OR IMPLIED, INCLUDING BUT NOT LIMITED TO ANY IMPLIED WARRANTY OF MERCHANTABILITY OR FITNESS FOR A PARTICULAR PURPOSE, WHICH ARE SPECIFICALLY DISCLAIMED. LIABILITY FOR BREACH OF THE ABOVE WARRANTY IS LIMITED TO COST OF REPAIR OR REPLACEMENT OF THE PRODUCT, AND UNDER NO CIRCUMSTANCES WILL THOMAS & BETTS BE LIABLE FOR ANY INDIRECT, SPECIAL, INCIDENTAL OR CONSEQUENTIAL DAMAGES.

Thomas & Betts Corporation
 Memphis, Tennessee
 Website: www.tnb.com