

COMPACT®

Pendant Arm Series 2 Couplings
Système de suspension série 2 Accouplements
Sistema de suspensión 2 Unión-acoplamientos

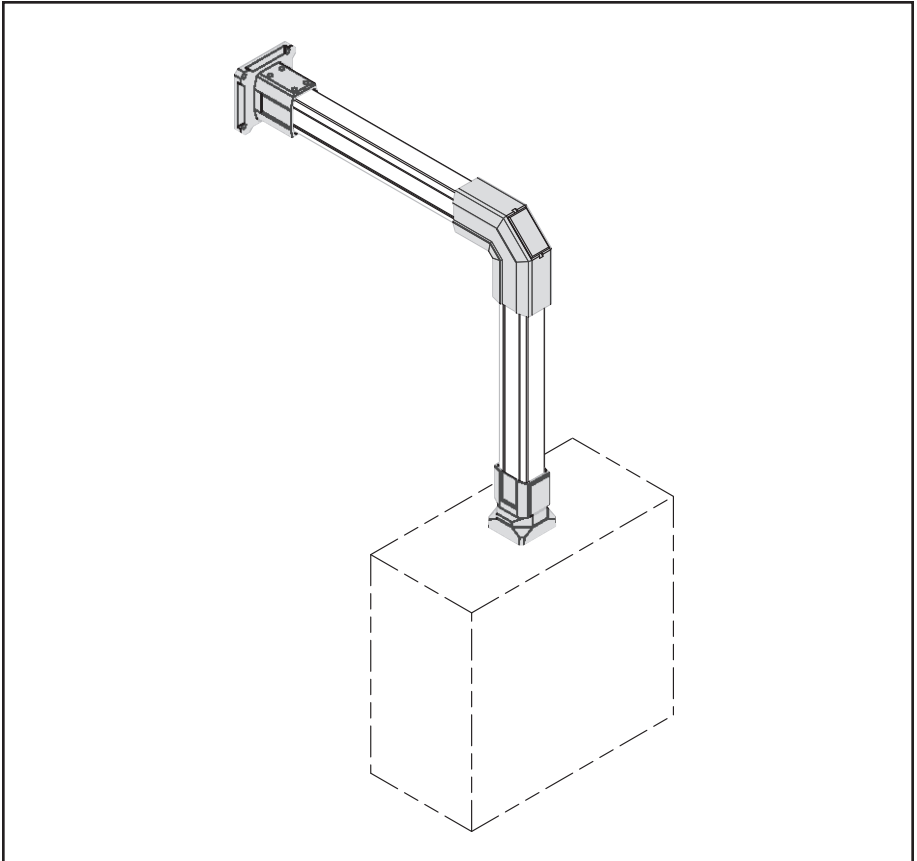

X		
$\frac{3.150}{80 \text{ mm}}$	CCS2FCLG CCS2FECLG	CCS2RBBLG
$\frac{3.228}{82 \text{ mm}}$	CCS2FC15LG CCS2FEC15LG	CCS2RBB15LG
$\frac{3.622}{92 \text{ mm}}$	CCS2STLG CCS2ESTLG	

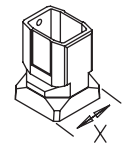
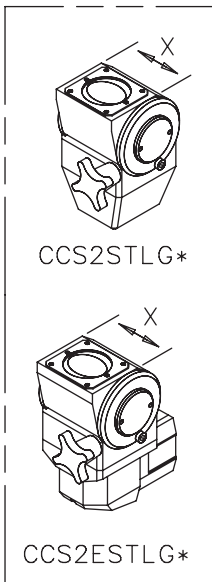
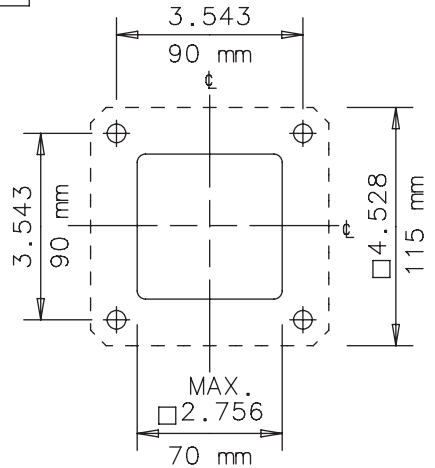
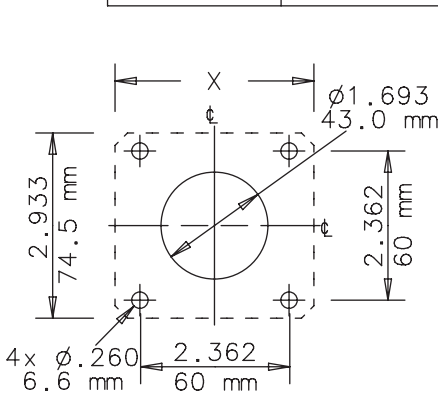

CCS2FCLG

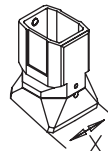

CCS2FC15LG

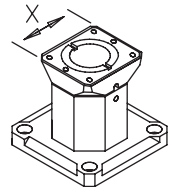

CCS2RBBLG

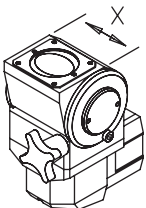

CCS2ESTLG*

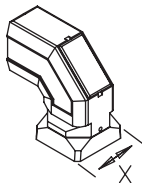

CCS2FECLG

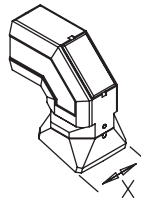

CCS2FEC15LG

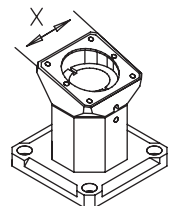

CCS2RBB15LG

* Maximum load 66 lbs/(30 Kg)
Charge maximum 66 livres (30 kilogrammes)
Carga máxima 66 libras (30 kilogramos)

901.2290.000

Optional Base Rotation Rotation Facultative De Fond Rotación Opcional De la Escuadra base

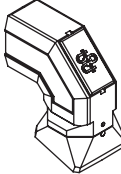
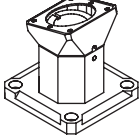
	CCS2FC15LG	CCS2FEC15LG	CCS2RBB15LG
(A)			
(B)	