

THIS COPY IS PROVIDED ON A RESTRICTED BASIS AND IS NOT TO BE USED IN ANY WAY DETRIMENTAL TO THE INTERESTS OF PANDUIT CORP.

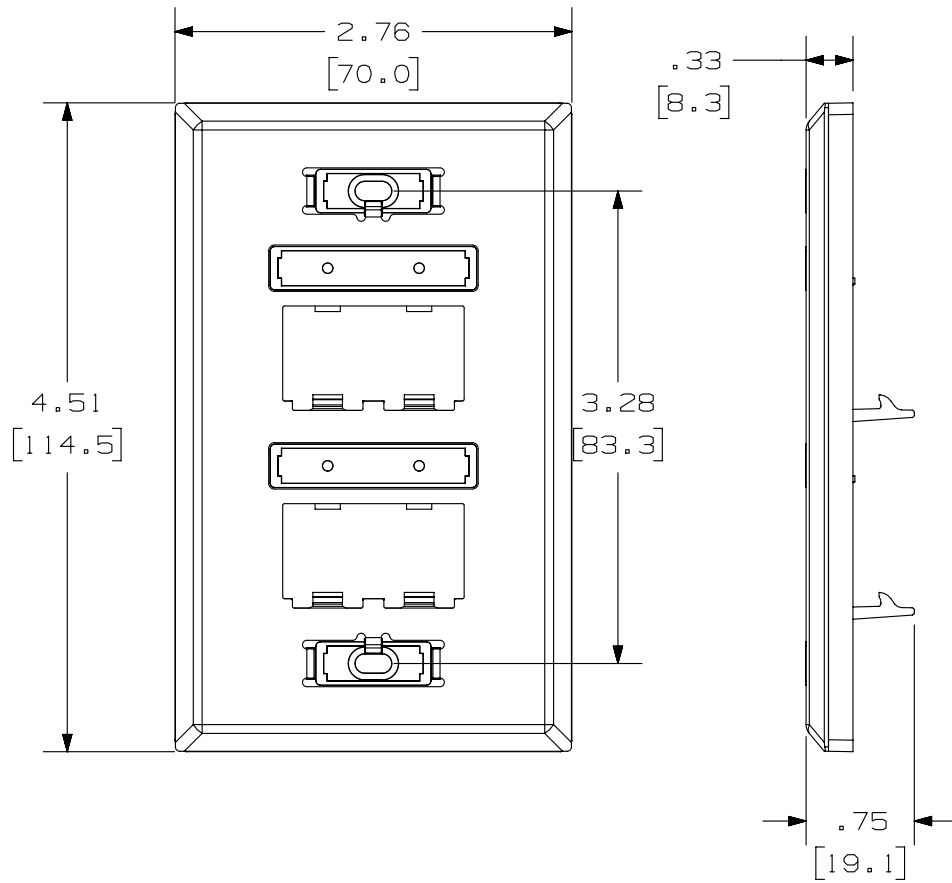

PANDUIT P/N	WEIGHT
UICFP4S	1.34 LB/10 PCS (609.7g/10 PCS)

NOTES:

- SEE CURRENT CATALOG FOR ADDITIONAL PART NUMBER SUFFIXES TO INDICATE COLOR AND OR PACKAGE QUANTITY.
- SEE CATALOG FOR COMPLETE LIST OF PARTS APPLICABLE FOR USE WITH THIS PART.
- DIMENSIONS IN PARENTHESES ARE IN METRIC.
- PART INCLUDES:
 - 1- FACEPLATE
 - 2- MOUNTING SCREWS
 - 1- CLEAR SCREW COVER
 - 1- COLOR COORDINATED SCREW COVER
 - 2- CLEAR LABEL COVER

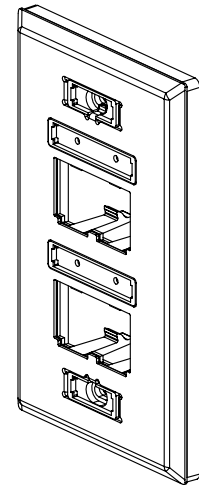

PART NUMBER		UICFP4S	
TITLE			
MINI-COM ULTIMATE ID 4 POSITION STAINLESS STEEL FACEPLATE			
CUSTOMER DRAWING			
ITEM REVISION NAME		M02237AB/01	
DATASET FILE NAME		M02237AB_DC/01B	
UNLESS OTHERWISE SPECIFIED, DIMENSIONAL TOLERANCES ARE: IN (mm)		MATERIAL:	
.x ± .xxx ± .010 [.3]		FACEPLATE:	
.xx ± .03 [.8] ANGLES ±		304 STAINLESS STEEL	
THIRD ANGLE PROJECTION		BACKING: ABS	
DRAWING NUMBER:		02237-08	
DRAWN BY	DATE	CHK	SCALE
JSP	4-4-07	JCO	NONE
REV	DATE	BY	CHK
1	5-20-14	BJN	JSP
APR	DESCRIPTION		ECN
	REVISED & REDRAWN PREVIOUS REVISIONS REMVD FOR CLARITY		02237-08
SHT 1 OF 1		A	

D10100DA/14