

ORDER NO.	PART NO.	THREAD DIA	COLOR
130128-0113	452	1/2"	GRAY
130128-0114	452CR	1/2"	YELLOW
130128-0115	453	3/4"	GRAY
130128-0116	453CR	3/4"	YELLOW
130128-0118	454	1"	GRAY
130128-0119	454CR	1"	YELLOW

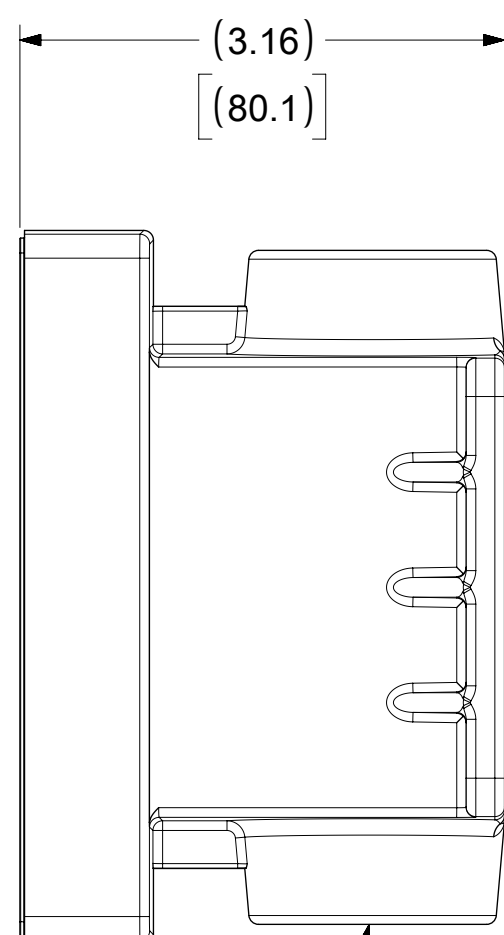
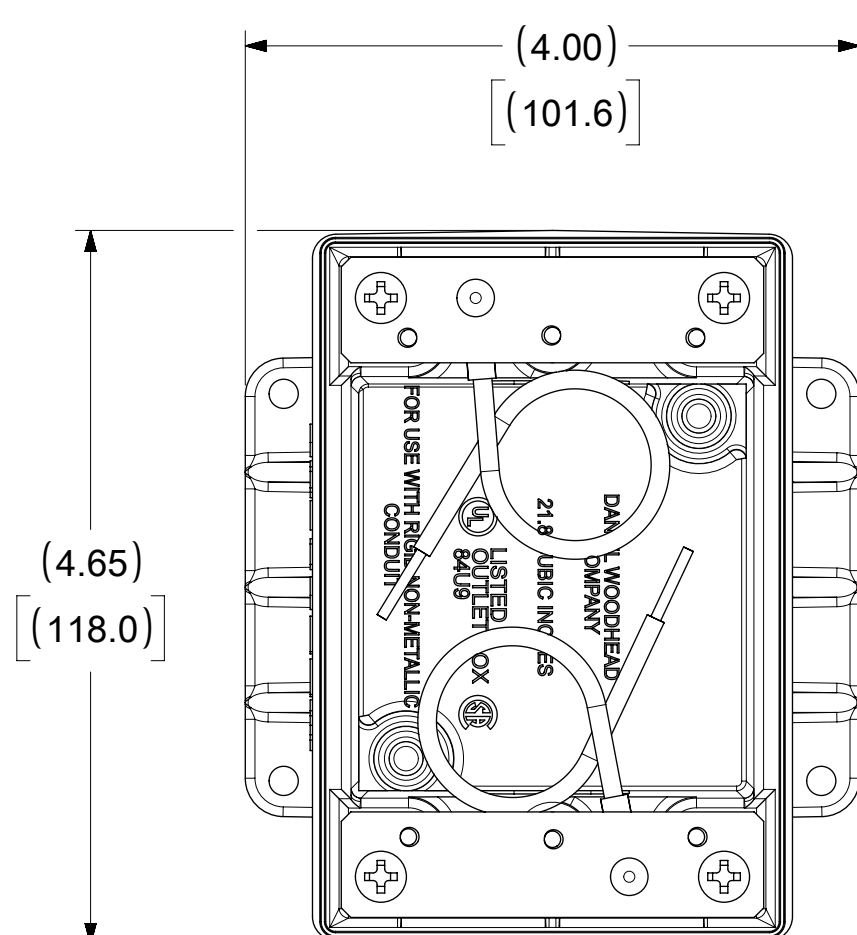
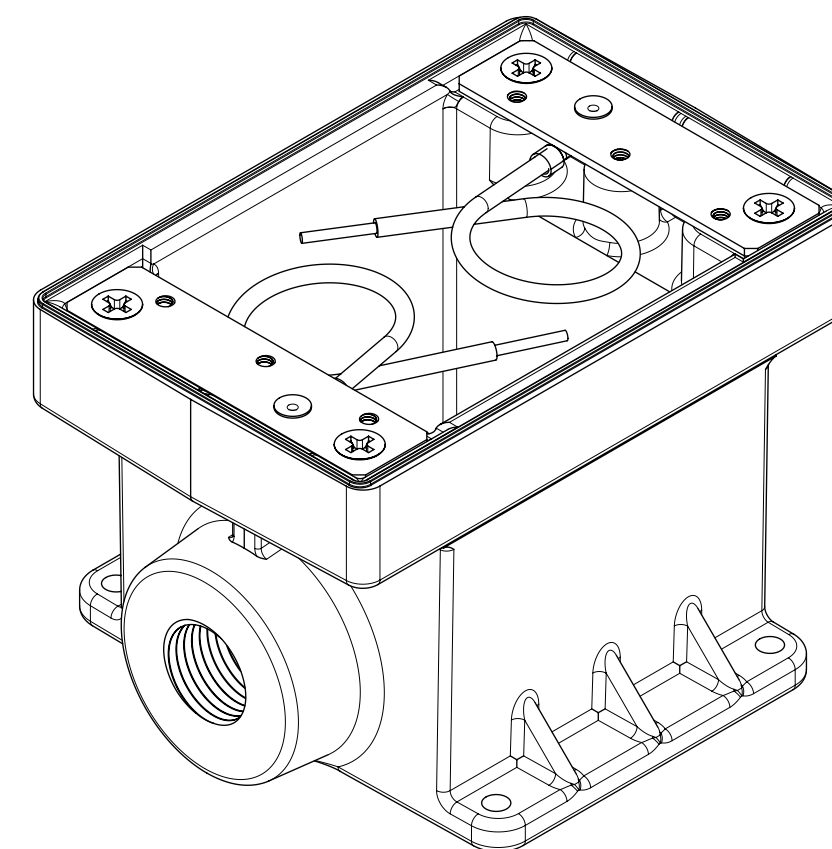

THREAD DIA BOTH SIDES

PRE-RELEASE
REFERENCE
USE ONLY

ITEM NO.	DESCRIPTION	MATERIAL	QTY.
1	F.D. BOX	BMC	1
2	RIVET	STAINLESS STEEL	2
3	JUMPER ASSY	COPPER, BRASS	2
4	MOUNTING PLATE	STAINLESS STEEL	2
5	SCREWS	STAINLESS STEEL	4

SYMBOLS		THIS DRAWING CONTAINS INFORMATION THAT IS PROPRIETARY TO MOLEX ELECTRONIC TECHNOLOGIES, LLC AND SHOULD NOT BE USED WITHOUT WRITTEN PERMISSION		CURRENT REV DESC: NEW RELEASE	
▽ = 0	INCH[MM]	SCALE		EC NO: 628785	
▽ = 0	NTS	GENERAL TOLERANCES (UNLESS SPECIFIED)		DRWN: VBASUTHKARP 2019/12/26	
▽ = 0		MM	INCH	CHK'D: DNGUYEN62 2020/01/02	
▽ = 0	4 PLACES ±	±	±	APPR:	
▽ = 0	3 PLACES ±	±	±	INITIAL REVISION:	
▽ = 0	2 PLACES ±	±	±	DRWN: VBASUTHKARP 2019/12/26	
▽ = 0	1 PLACE ±	±	±	APPR:	
▽ = 0	0 PLACES ±	±	±	THIRD ANGLE PROJECTION	
▽ = 0	ANGULAR TOL ± °	DRAFT WHERE APPLICABLE MUST REMAIN WITHIN DIMENSIONS		DRAWING	SERIES
▽ = 0				C-SIZE	130128

			F.D. BOX FOR SURFACE OR RECESS MOUNTING		
			PRODUCT CUSTOMER DRAWING		
DOCUMENT NUMBER		DOC TYPE	DOC PART	REVISION	
1301280113		PSD	000	A	
MATERIAL NUMBER		CUSTOMER		SHEET NUMBER	
SEE TABLE		GENERAL MARKET		1 OF 1	

DOCUMENT STATUS	RV	RELEASE DATE