

M-13314

1

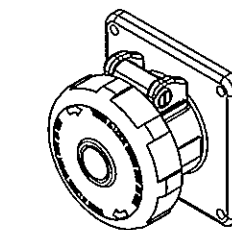
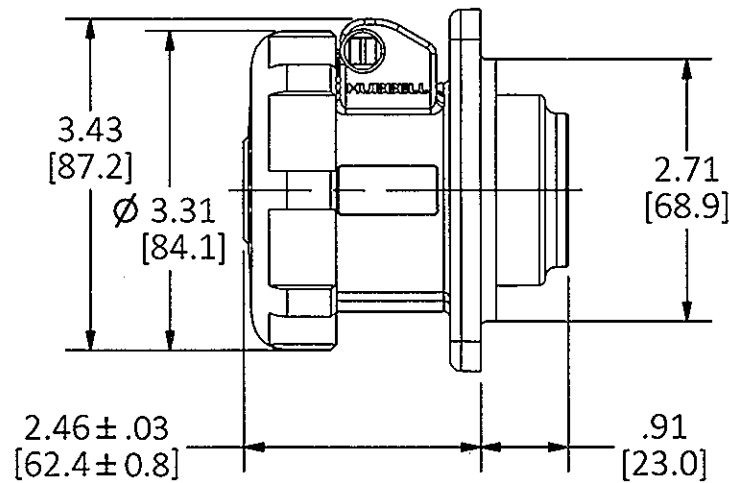
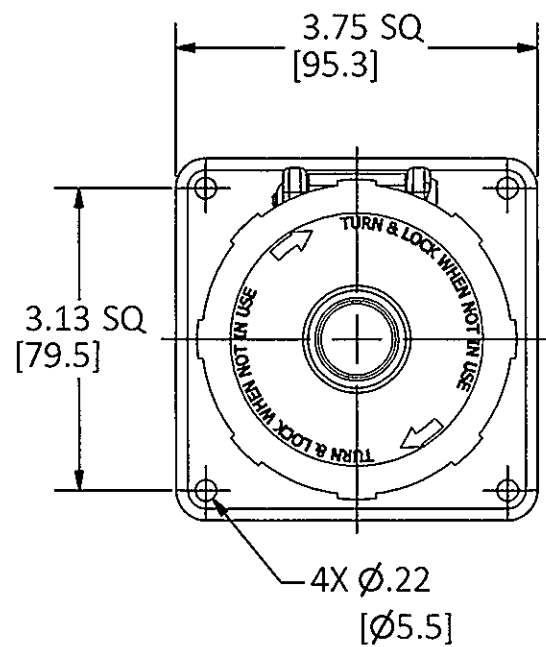

CAT. NO.	CONFIG.	RATING	HOUSING COLOR
HBL420R5W		20A 600VAC 3Ø	BLACK
HBL420R6W		20A 380-415VAC 3Ø 16A - 6h/380-415V~	RED
HBL420R7W		20A 480VAC 3Ø	RED
HBL420R9W		20A 250VAC 3Ø 16A - 9h/200-250V~	BLUE
HBL420R12W		20A 125/250VAC	ORANGE

LIST OF PARTS

DESCRIPTION	MATERIAL	FINISH
HOUSING	PBT	
INTERIOR	THERMOSET	
SLEEVES	BRASS	
SLEEVE SPRINGS	ST. STEEL	
TERMINAL SCR.	ST. STEEL	
COVER	PBT	
GASKET	CLOSED CELL FOAM	
HINGE ARM	PBT	
HINGE PIN	BRASS	NICKEL
HINGE SPRING	ST. STEEL	
GLAND CAP	PBT	
GLANDS	NEOPRENE	
CLAMPS	PBT	
CLAMP NUTS	BRASS	NICKEL
ASSY. SCREWS	ST. STEEL	

DIMENSION SHEET FOR CAT. NO. SEE TABLE

1	INITIAL RELEASE PER DCN 21982 Mr.B <i>Mr.B</i>	TLS	3/10/16
REV	DESCRIPTION	APP	DATE

THE DESIGN AND DIMENSIONS OF THE PRODUCT SHOWN ON THIS DRAWING ARE SUBJECT TO CHANGE WITHOUT NOTICE. DIMENSIONS ARE IN INCHES [mm].

TITLE
20A & 16A 3 POLE 4 WIRE PIN AND SLEEVE RECEPTACLE



WIRING DEVICE-KELLEMS
HUBBELL INCORPORATED
SHELTON, CT

TOLERANCES UNLESS OTHERWISE SPECIFIED .XX = ± .01 .XXX = ± .005 ANGLE TOL. ±2'	DR. BY Mr.B	SCALE 1 : 2
	CHK. BY TLS	DATE 3/2/16

B

M-13314

1