

M-1477 8

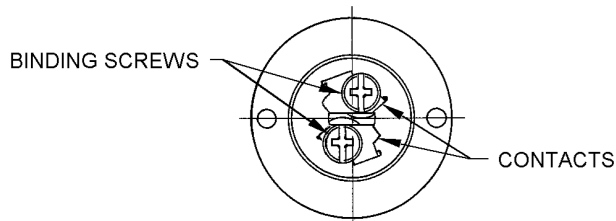
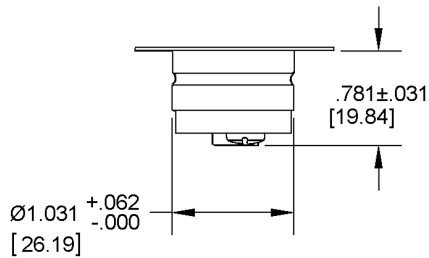
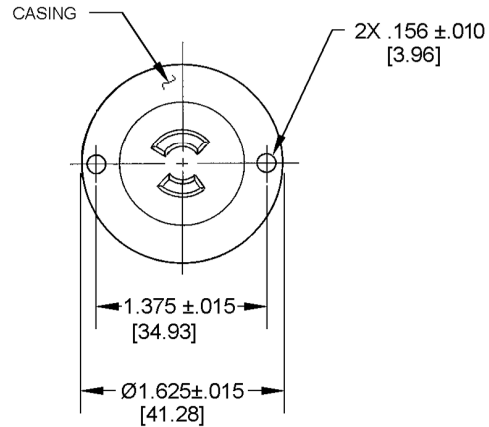

1. DIMENSIONS ARE IN INCHES [MM]
2. PREFIX "HBL" WAS ADDED TO CATALOG NUMBER 7468 AS AN EDITORIAL CHANGE ONLY. NO CHANGES WERE MADE TO THE FORM, FIT, OR FUNCTION OF THE DEVICE.

LIST OF PARTS

DESCRIPTION	MATERIAL	FINISH
(2) MOUNTING SCREWS	BRASS	NICKEL PLATED
BODY	<b>POLYESTER</b>	————
#5-40 UNC BINDING SCREW	BRASS	————
#5-40 UNC BINDING SCREW	BRASS	NICKEL PLATED
CONTACT	BRONZE	————
CONTACT	BRONZE	NICKEL PLATED
CASING	STAINLESS STL.	POLISHED FACE

SUPERSEDES DWG. DATED 2/12/54

SYM	REVISIONS	APP	DATE
8	PARTS LIST: BODY MATERIAL POLYESTER WAS PHENOLIC PER DCN 22625 RM	DJP	10/2/17
7	PICTORIAL CHANGE TO BOTTOM VIEW TO SHOW COMBO DRIVE SCREWS PER DCN 23087 RM	DJP	5/23/17
6	ADDED NOTE 2 PER DCN 16778. MYA	TCM	6/25/10
5	ADDED NOTE 1; REMOVED NOTE FOR TORQUE FOR BODY; ADDED METRIC TO ALL DIMS.; .156±.010 WAS .156±.005 PER DCN 16134 RCM	DJP	11/18/09
4	REDRAWN ON NEW DRAWING FORMAT. CONVERTED FRACTIONS TO DECIMALS. PARTS LIST, CASING, STAINLESS STL WAS BRASS. ADDED CALLOUTS FOR CASING, BODY, BINDING SCREWS AND CONTACTS. PER DCN 14376 SPN	DJP	11/13/07

THE DESIGN AND DIMENSIONS OF THE PRODUCT SHOWN ON THIS DRAWING ARE SUBJECT TO CHANGE WITHOUT NOTICE

TITLE DIMENSION SHEET FOR CATALOG HBL7468

TOLERANCES UNLESS OTHERWISE SPECIFIED		WIRING DEVICE - KELLEMS HUBBELL INCORPORATED SHELTON, CT.	
FRACTIONS	±1/64	DR. BY	A S
DECIMALS	±.005	APP. BY	DJP
ANGLES	±2°	TR. BY	SPN
		SCALE	FULL
		CHK'D BY	A S
		DATE	11/13/07