

M-12510

2

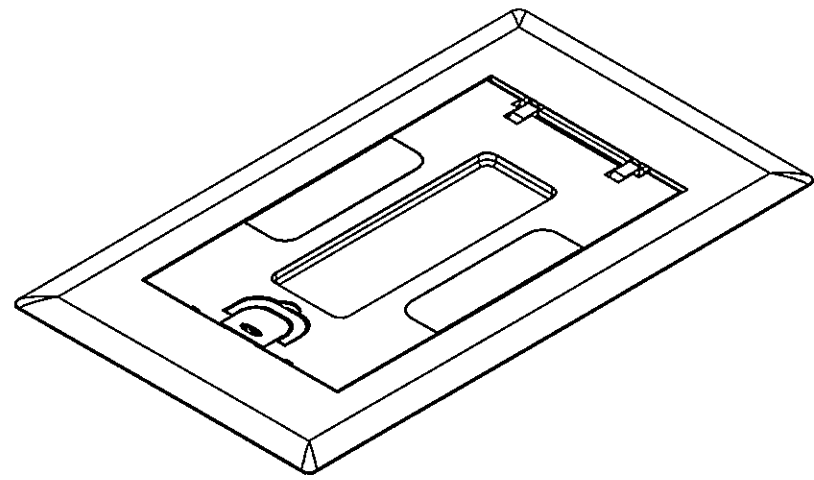

RECESS

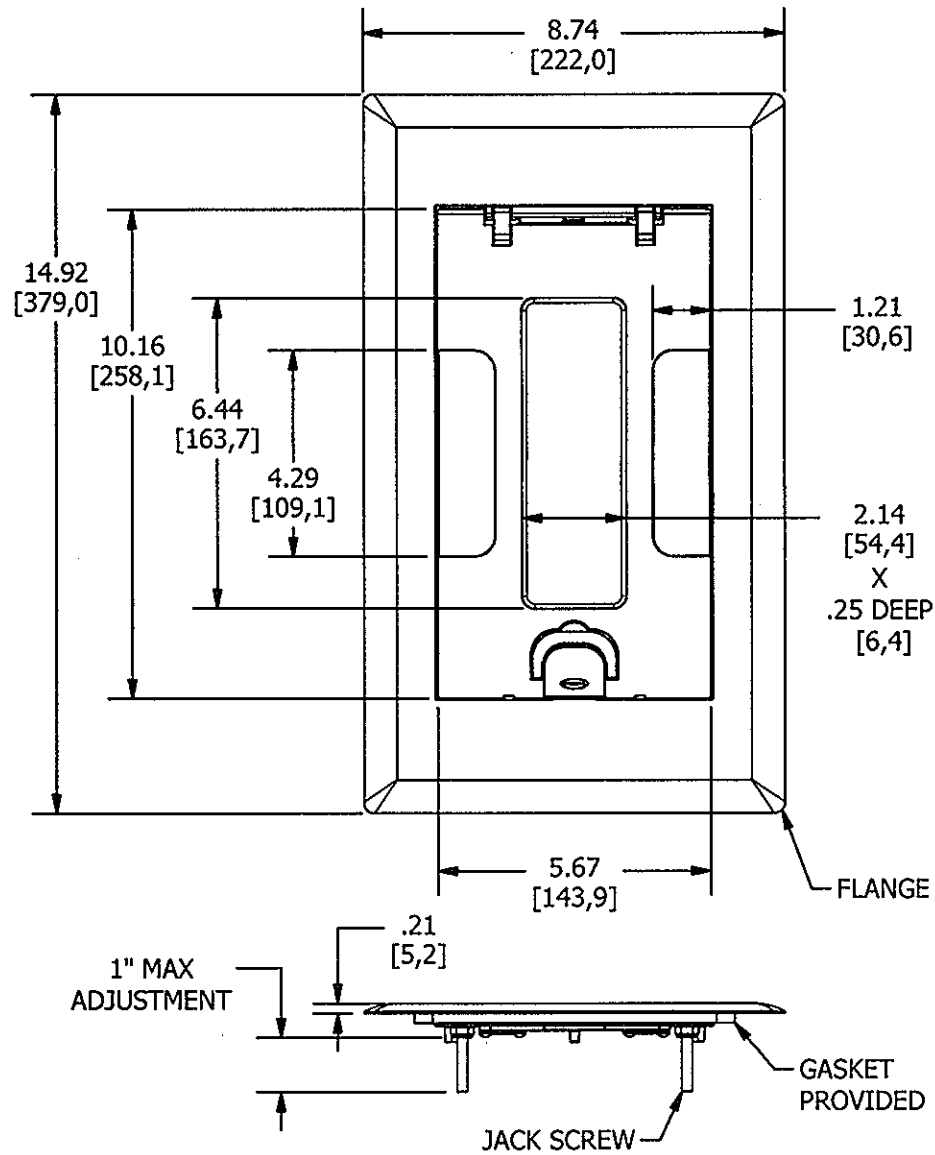

RECESS	
CATALOG NO.	COLOR
2GAFBCVRNKC	NICKEL
2GAFBCVRBKC	BLACK
2GAFBCVRALUC	ALUMINUM
2GAFBCVRBRSC	BRASS
2GAFBCVRBRZC	BRONZE

NOTES: UNLESS OTHERWISE SPECIFIED:
 1. DIMENSIONS SHOWN ON THIS DRAWING ARE NOMINAL VALUES FOR GENERAL USE ONLY.
 2. PRODUCT IS cULus LISTED.

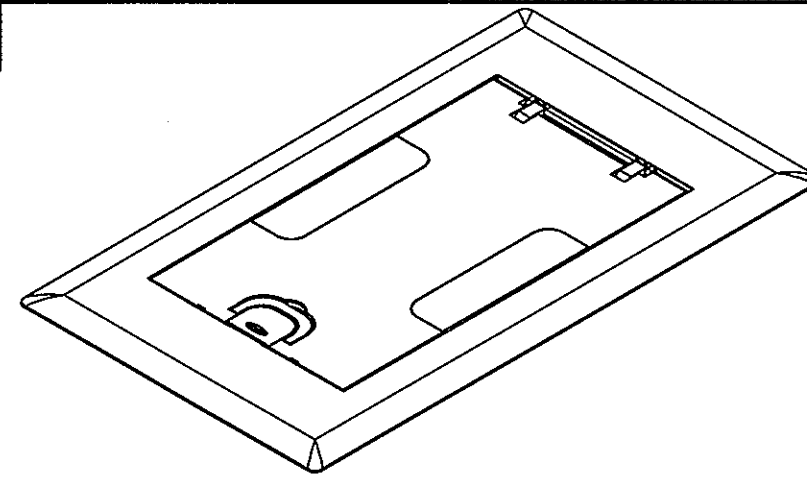

NO RECESS

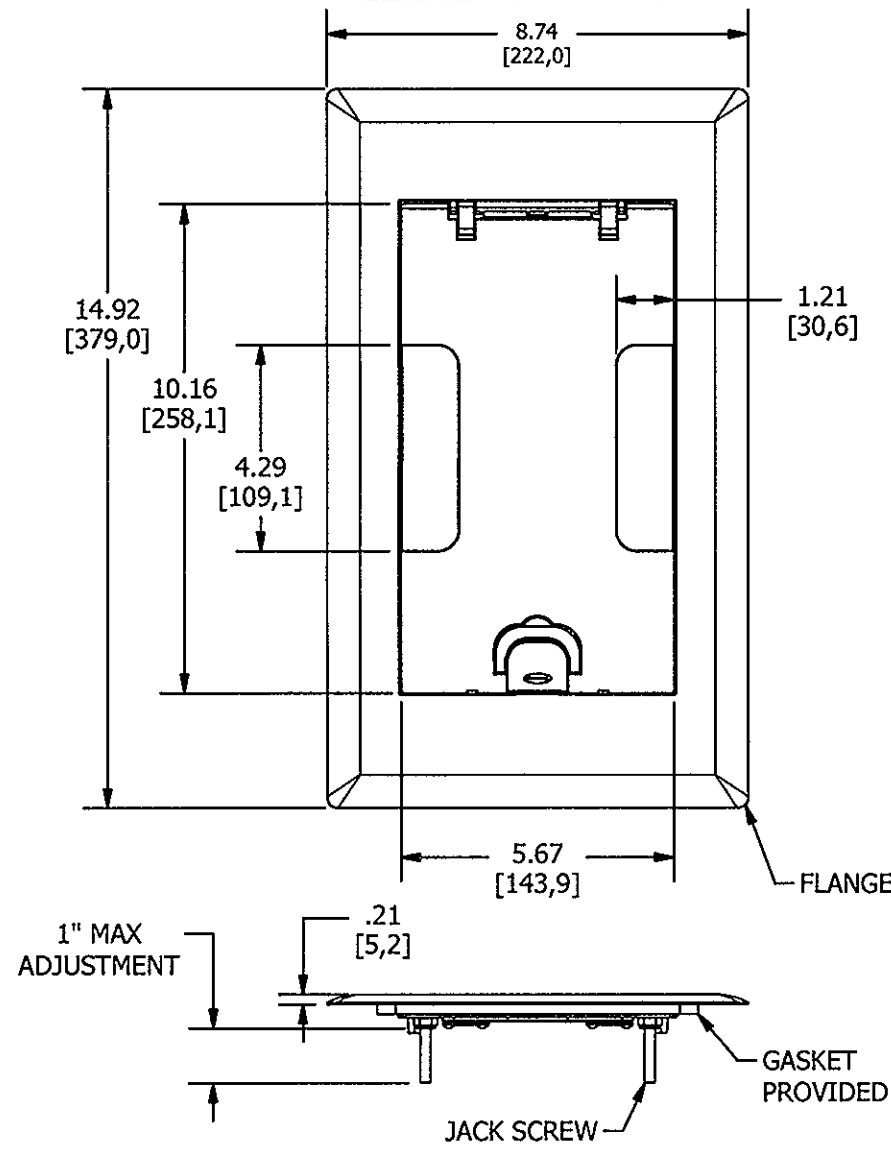

NO RECESS	
CATALOG NO.	COLOR
2GAFBCVRNK	NICKEL
2GAFBCVRBK	BLACK
2GAFBCVRALU	ALUMINUM
2GAFBCVRBRS	BRASS
2GAFBCVRBRZ	BRONZE

LIST OF PARTS

DESCRIPTION	MATERIAL	FINISH
FLANGE	ALUMINUM	POWDER COAT
COVER	ALUMINUM	POWDER COAT
GASKETS	CLOSED CELL FOAM	
HINGE SUPPORT	ALUMINUM	POWDER COAT
PIVOT LINK	ALUMINUM	POWDER COAT
HINGE PIN LONG	STAINLESS	
HINGE PIN SHORT	STAINLESS	
SUPPORT HINGE PIN	CRS	PRE GALVANIZED
DOOR STRAP	CRS	PRE GALVANIZED
EGRESS DOOR	ALUMINUM	POWDER COAT
EGRESS DOOR SPRING	STAINLESS	
BUTTON SLIDE	ALUMINUM	POWDER COAT
SPRING BUTTON	STAINLESS	
LATCH	ALUMINUM	POWDER COAT
JACK SCREW	STEEL WIRE	ZINC PLATED
JACK SCREW NUT	CRS	ZINC PLATED

DIMENSION SHEET FOR CAT. NO.

SEE TABLE

REPAIRABLE

NON-REPAIRABLE

B

M-12510

2

2	ADDED ISO VIEWS PER DCN # 20587 MAM RGP <i>Rep</i>	TLS	6/13/2014
1	RELEASED FOR PRODUCTION PER DCN # 20081 RGP TLS	TLS	09/20/13
SYM	DESCRIPTION	APP.	DATE

THE DESIGN AND DIMENSIONS OF THE PRODUCT SHOWN ON THIS DRAWING ARE SUBJECT TO CHANGE WITHOUT NOTICE

TITLE
 2 GANG AFB COVER ASSY.
 RECESS & NO RECESS

TOLERANCES UNLESS OTHERWISE SPECIFIED	WIRING DEVICE-KELLEMS HUBBELL INCORPORATED SHELTON, CT			
FRACTIONS ± 1/64	DR. BY	RGP	APP. BY	TLS
DECIMALS ± .03	TR. BY		SCALE	1 : 4
ANGLES ± 2'	CHK'D BY	TLS	DATE	9/10/2013