

E32 eSM

Multiplexed rocker switch units



Total flexible solution

Multiplexed Master Module using a LIN sub bus to communicate with up to seven expansion modules

Offering a high level of flexibility, the above-panel electronic multiplex switch module (eSM) covers your wide range of switch and indicator applications using standard or custom graphics, as well as a full range of circuits and illumination options. The above-panel eSM has top, center and bottom LED lighting with software that offers advanced circuit and lighting flexibility, including dimming and flashing options via J1939 CANbus communication. The indicator bar can be lighted with up to four separate colors to indicate operational status, vehicle mode and faults. All standard combinations of maintained and momentary switch actions, matching indicator caps and dummy plugs, along with the complementary styled SVR electromechanical rocker switch, are available to complete the offering.

Compared with electromechanical switches, multiplexed switch modules offer several advantages

- Reduced assembly labor due to ease of installation, allowing for mounting and connection of three switches at one time versus individually
- Reduced wire harness complexity, using one harness to a controller to accommodate up to 24 switches and a three-wire interconnect between expansion and master modules
- Reduced harness size offers an overall reduction in weight, improving operational efficiency of the equipment
- Increase in switch life-cycle over traditional electromechanical switches (500k cycles)

Additional features and benefits

- Fully compliant with J1939 messaging
- IP53 degree of protection
- CAN controlled digital logic output—500 mA DC
- Center indicator illumination with up to four independent LEDs for status and mode operation
- Harness address assignment
- 12V and 24 Vdc options available
- Immune to SAE J1455 and J1113 power disturbances
- Front panel removable for ease of maintenance
- Sleep mode available to reduce current draw on the battery
- Wake on switch change configurable
- Illumination is dimmable on both top and bottom icons
- Decorative-style rocker with matching indicator option available
- Late point definition achieved by rocker and subactuator defining circuit function

Target market segments

This product is targeted at the bus/coach, truck and specialty vehicle markets. The product is especially suitable where a customer has “gangs” of switches mounted in a panel or a dashboard, and expansion modules can be connected easily to a master module.

- Motor coach / bus
- On-road specialty vehicle
- Heavy truck
- Recreational vehicles
- Street sweepers
- Refuse vehicles
- EMS vehicles



E32 Above-Panel Electronic Multiplex Switch Module (eSM)



Powering Business Worldwide

Master module wire harness

The interconnection between master module and controller uses a simple four-wire harness with addressing specified by jumping between pins 6 to 9. An additional pin-out is provided for a 500 mA output if required.

Mating connector information:

Housing: Amp/Tyco #1394048-1
Cover: Amp/Tyco #2-1355524-3

Pin	Function
1	VBAT (clamp 30)
2	Ground
3	CAN high
4	CAN low
5	500 mA output
6	Address 1
7	Address 2
8	Address 3
9	Address 4
10	No connect
11	No connect
12	No connect

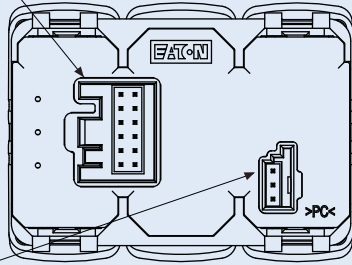

Pin	Function
1	VBAT (Clamp 30)
2	Ground
3	LIN sub bus

Mounting

The modules are easily mounted with plastic retention clips. Clips can be compressed from the front for easy removal. Modules are mounted in a single, space-saving cutout, reducing assembly time and accommodating up to three switches in a compact design.

The unit will accommodate 1.5 to 3 mm panel thickness.

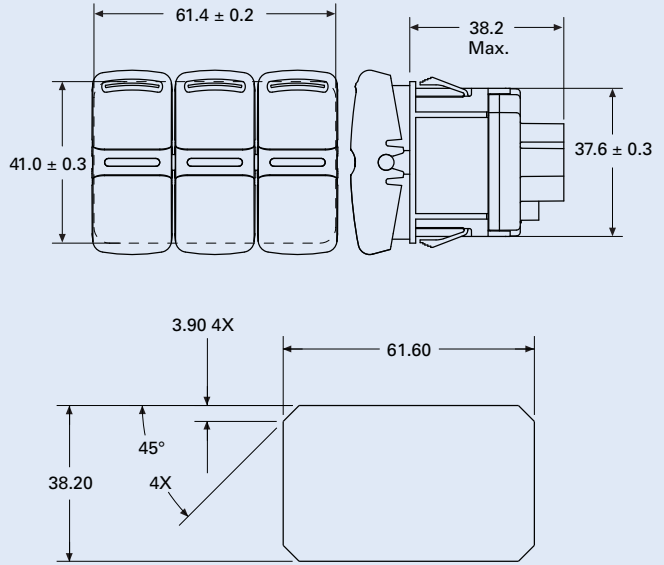

Expansion module wire harness

The interconnection between modules uses a cost-effective three-wire harness. This simplified wire harness reduces cost, weight and assembly labor for the end-user.

Mating connector information:

Amp/Tyco #1-1718346-1 Coding A

Pin	Function
1	VBAT (Clamp 30)
2	Gnd
3	LIN sub bus

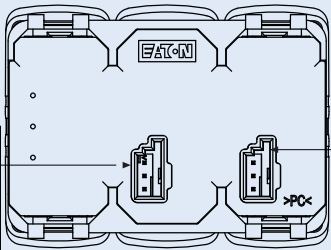

Pin	Function
1	VBAT (Clamp 30)
2	Ground
3	LIN sub bus

E31 keypad eSM

The Eaton E31 keypad expansion module offers exceptional complimentary features to the E32 eSM. It is sealed to IP68 for severe environment mounting and contain up to four unique daylight visible indicator colors per switch, offering exceptional visual feedback to your operators. Additionally, the E31 keypad expansion eSM communicates directly with the E32 eSM master module via the standard three-wire LIN connection without impacting additional nodes on your controller.



Eaton
1000 Eaton Boulevard
Cleveland, OH 44122 USA
Eaton.com

© 2013 Eaton
All Rights Reserved
Printed in USA
Publication No. PA07002004E / Z13520
April 2013

Eaton is a registered trademark of Eaton Corporation.

All other trademarks are property of their respective owners.