

SECTION B-B

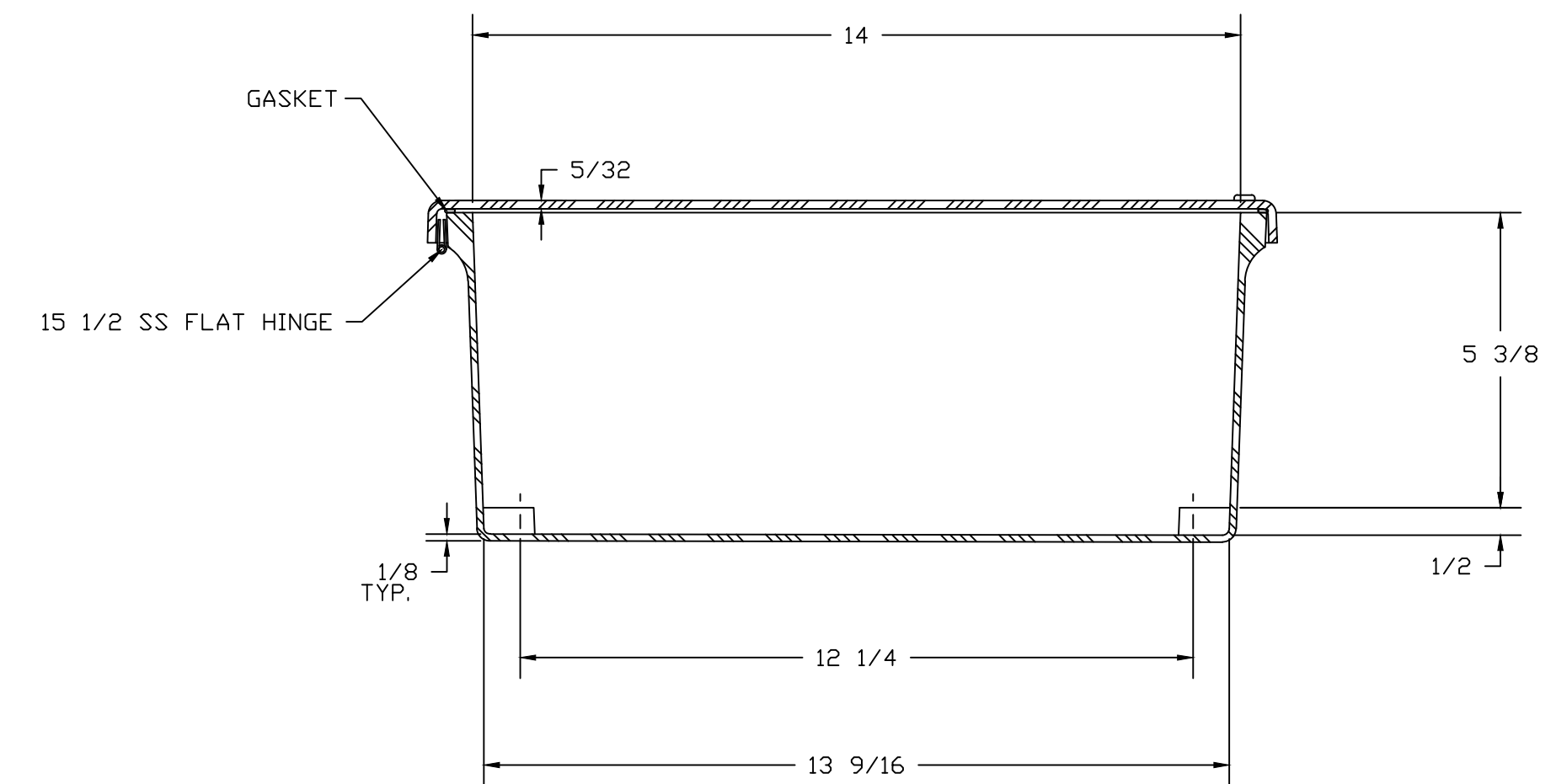
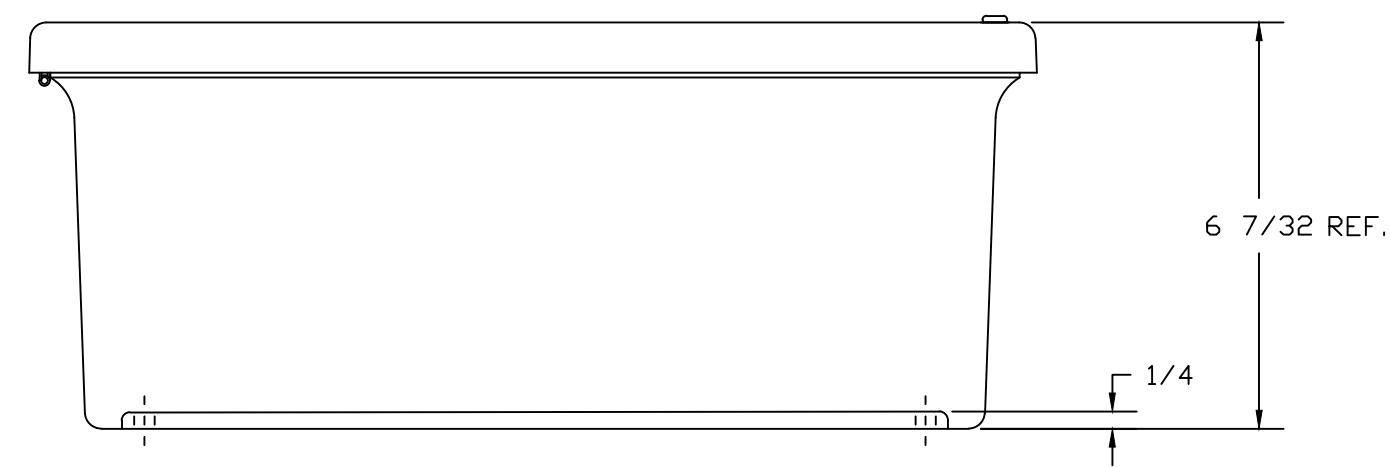

SECTION A-A

NOTES:

NEMA 4X		TOLERANCES UNLESS SPECIFIED		DECIMAL ±.010	FRACTIONAL ± 1/32
COLD GLACIER GRAY RR1013					
MATERIAL	F.R. POLYESTER FIBERGLASS	DR. BY	SH	DATE	6/14/91
LET.	REVISION RECORD	DATE	BY	CHD.	CHK. BY
					DATE
		APD. BY	DATE		
		SCALE DO NOT SCALE		PART NAME	ENCLOSURE
		PART NO.		J1614HW	



BELDING, MICHIGAN  
48809

AutoCAD DWG. FILE  
J1614HW