

THIS COPY IS PROVIDED ON A RESTRICTED BASIS AND IS NOT TO BE USED IN ANY WAY DETRIMENTAL TO THE INTERESTS OF PANDUIT CORP.

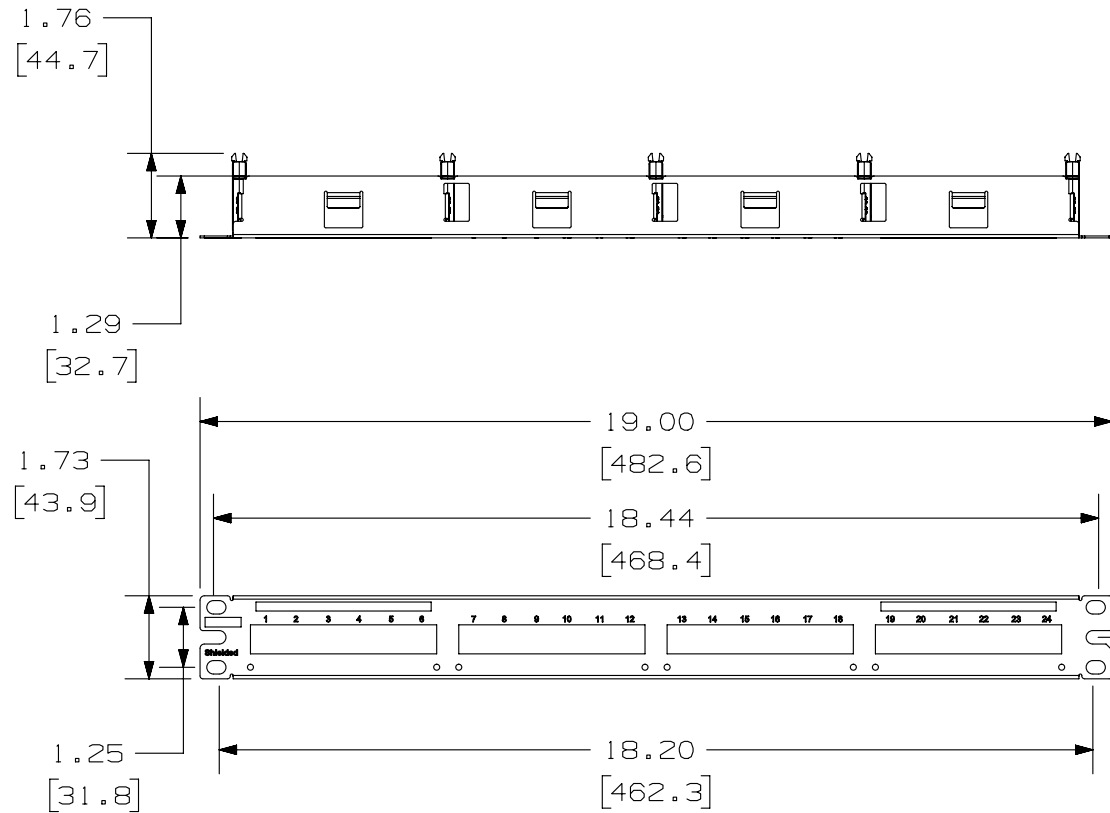

PANDUIT PART NO.	WEIGHT (APPOX.)
QSP24BL	0.71 lb (322 g)

NOTES:

- SEE CURRENT CATALOG FOR VARIOUS APPLICATIONS.
- THE PATCH PANEL IS DESIGNED FOR MOUNTING TO 19" UNIVERSAL RACKS.
- DIMENSIONS IN BRACKETS ARE IN METRIC.
- PART INCLUDES:
 - 1- METAL STAMPING WITH SLIDE GUIDES
 - 1- SCREW KIT (INCLUDES FOUR #12-24 BONDING SCREWS)
 - 1- SCREW KIT (INCLUDES FOUR M6 BONDING SCREWS)

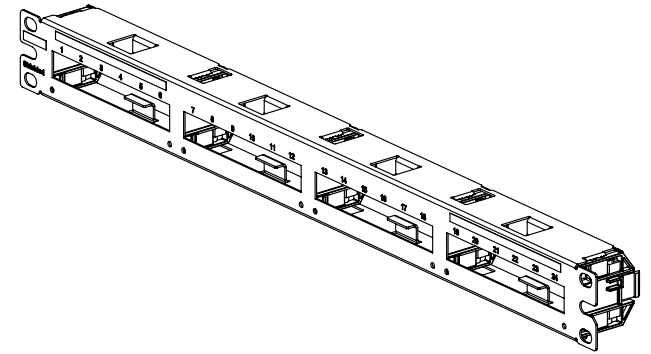

PART NUMBER		QSP24BL	
TITLE			
QUICKNET 24 PORT SHIELDED PATCH PANEL			
CUSTOMER DRAWING			
ITEM REVISION NAME		M02816AB/02	
DATASET FILE NAME		M02816AB_DC18/02A	
UNLESS OTHERWISE SPECIFIED, DIMENSIONAL TOLERANCES ARE: IN [mm]		MATERIAL:	
.x ± .xxx ± .010 [.3]		PANEL: STAINLESS STEEL	
.xx ± .03 [.8] ANGLES ±		GUIDES: ABS	
DRAWING NUMBER:		02816-18	
DRAWN BY		SCALE	
JSP		NONE	
DATE		SHT 1 OF 1	
3/25/14		A	
CHK		SIZE	
REFR		A	

REV	DATE	BY	CHK	APR	DESCRIPTION	ECN
R	3/25/14	JSP	REFR	TMBA	RELEASED TO PRODCUTION	02816-18

D10100DA/14