

THIS COPY IS PROVIDED ON A RESTRICTED BASIS AND IS NOT TO BE USED IN ANY WAY DETRIMENTAL TO THE INTERESTS OF PANDUIT CORP.

PANDUIT P/N	WEIGHT
KWP5EY	1.40 LB/10 PCS (635.3 g/10 PCS)

NOTES:

- SEE CATALOG FOR COMPLETE LIST OF PARTS APPLICABLE FOR USE WITH THIS PART.
- DIMENSIONS IN PARENTHESES ARE IN METRIC.
- KWP5EY CONTAINS:
 - WALL PLATE
 - KEYSTONE TX5e MODULE
 - MOUNTING SCREW

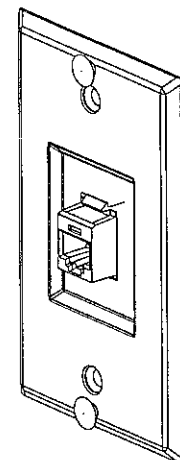
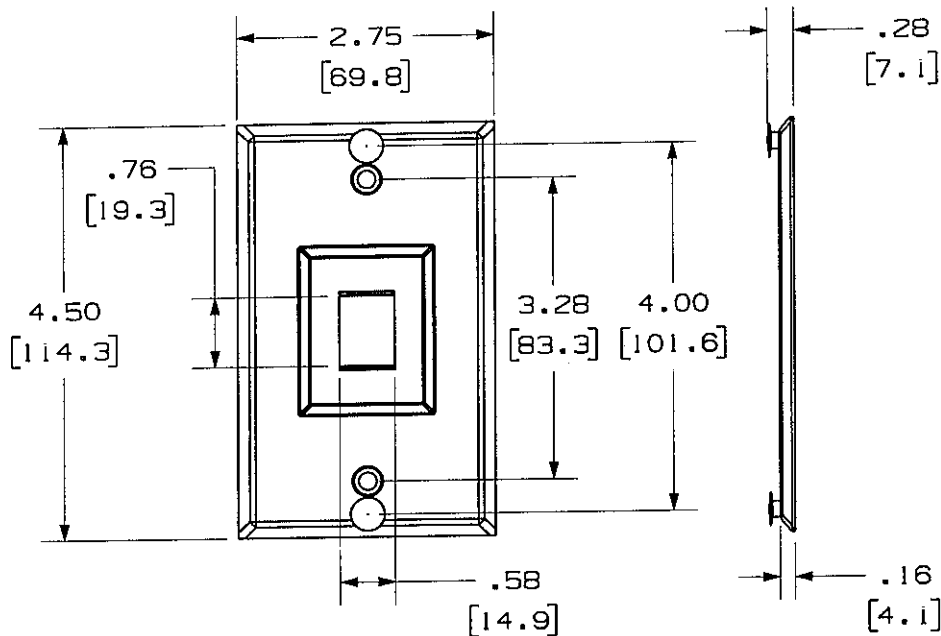

NETWORK SYSTEMS
MAY 26 2006
ENGINEERING DEPT

DRAWING FILENAME		M02479BN_DC40_00A.PRT	SIZE	A
PHONE PLATE WITH TX5e KEYSTONE MODULE CUSTOMER DRAWING				
I.I. NUMBER		N/A		
PRODUCT SPEC		N/A		
WORK INSTRUCTION		N/A		
SCALE		NONE		
PART NO.		KWP5EY		
DRAWING NO.		02479-040		



ALL DIMENSIONS ARE GIVEN IN INCHES, UNLESS OTHERWISE SPECIFIED.
DIMENSIONAL TOLERANCES ARE:
(.X1) ± (.XXX) ± .010(.3)
(.XX) ± .031(.8) ANGLES ±

THIRD ANGLE PROJECTION
DRAWN BY: JsP
DATE: 5-3-06
MATERIAL: 20 AWG 430 STAINLESS STEEL

REV	DATE	BY	CHK	DESCRIPTION	ECN	R	CUST	SUP	OTH
R	5-3-06	JsP	MAD	RELEASED TO PRODUCTION	02479-040	MAD	MAD		