

Installation Instructions

15kV & 28kV Ranger 2 Shrink fit Silicone Rubber Termination Indoor/Outdoor Application with High-K Stress Relief for Tape shield, Wire Shield & Unishield® Cables

Contents: Silicone Rubber Termination, Lubricant, 2-Strips Grey Silicone Rubber Tape, Constant Force Spring, Preformed Ground Braid, 2-Strips Sealing Mastic, 1-Strip Copper Foil Tape, 2-Gloves, Instruction Sheets.

Optional Contents: Connector, Cable Support Bracket.

DANGER

All apparatus must be de-energized during installation or removal of part(s).

All apparatus must be installed and operated in accordance with individual user, local, and national work rules. These instructions do not attempt to provide for every possible contingency.

Do not touch or move energized products.

Excess distortion of the assembled product may result in its failure.

Inspect parts for damage, rating and compatibility with mating parts.

FOR MORE INFORMATION ON PARTS, INSTALLATION RATINGS AND COMPATIBILITY, CALL THE NEAREST ELASTIMOLD OFFICE.

This product should be installed only by competent personnel trained in good safety practices involving high voltage electrical equipment. These instructions are not intended as a substitute for adequate training or experience in such safety practices.

Failure to follow these instructions will result in damage to the product and serious or fatal injury.

If this product is supplied with a protective shipping cover(s), remove this shipping cover(s) and replace with the appropriate HV insulated cap(s) or connector(s) before submerging or energizing the circuit.

WARRANTY: Thomas & Betts warrants that this product will be free from defects in materials and workmanship for the period of two (2) years from the date of shipment. Upon prompt notification of any warranted defect, Thomas & Betts will, at its option, repair, replace or refund the purchase price. Proof of purchase is required. Unauthorized modification or improper installation will void all warranties.

Limitations and Exclusions: THE ABOVE WARRANTY IS THE SOLE WARRANTY CONCERNING THIS PRODUCT, AND IS IN LIEU OF ALL OTHER WARRANTIES EXPRESS OR IMPLIED, INCLUDING BUT NOT LIMITED TO ANY IMPLIED WARRANTY OF MERCHANTABILITY OR FITNESS FOR A PARTICULAR PURPOSE, WHICH ARE SPECIFICALLY DISCLAIMED. LIABILITY FOR BREACH OF THE ABOVE WARRANTY IS LIMITED TO COST OF REPAIR OR REPLACEMENT OF THE PRODUCT, AND UNDER NO CIRCUMSTANCES WILL THOMAS & BETTS BE LIABLE FOR ANY INDIRECT, SPECIAL, INCIDENTAL OR CONSEQUENTIAL DAMAGES.

IMPORTANT

1. Check contents of package to ensure they are complete and undamaged.
2. Check all components to ensure proper fit with cable and/or mating products.
3. Read entire installation instructions before starting.
4. Have all required tools at hand and maintain cleanliness throughout the procedure.

Termination Selection Chart

* Confirm Cable Insulation Diameter is with the Ranged Listed

Catalog Number	Dia. Over Insulation Inches (mm)	Dia. Over Jacket Inches (mm)	Typical 15kV Cables (100% level, 175mil)	Typical 15kV Cables (133% level, 220mil)	Typical 25kV Cables
R2T15M1	0.64-1.12 (15-30)	1.35 (35) MAX	#1-250 Kcmil*	#2-250 Kcmil*	-----
R2T15M2	0.84-1.38 (20-35)	1.72 (45) MAX	4/0-500 Kcmil*	2/0-500 Kcmil*	-----
R2T15M4	1.30-2.10 (35-55)	2.55 (65) MAX	750-1250 Kcmil*	750-1250 Kcmil*	-----
R2T28M2	0.84-1.38 (20-35)	1.72 (45) MAX	-----	-----	1/0-4/0 Kcmil*
R2T28M4	1.30-2.10 (35-55)	2.55 (65) MAX	-----	-----	500-1250- Kcmil*

Tape Shield - Page 2

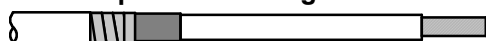

Wire Shield - Page 5

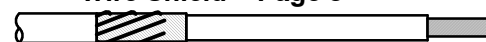

UniShield® - Page 8

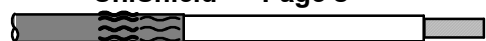

Cable Support Bracket (Optional)

Catalog Number	Overall Cable Diameter	Bracket Style
B1	.800-1.250 20 - 32mm	Single
B2	1.100-1.500 28 - 38mm	Single
B3	1.450-1.950 37 - 50mm	Double

Table 1

Catalog Number	Rating (kV)	Dimension A (See Fig. 1) In. (mm)
R2T15M1	15	7.5 (190)
R2T15M2	15	7.5 (190)
R2T15M4	15	7.5 (190)
R2T28M2	28	10.5 (270)
R2T28M4	28	10.5 (270)

Tape Shielded Cable

STEP 1 Prepare Cable

1. Check to be sure cable size fits within kit range as shown in the Termination Selection Chart, Page 1.
2. Train cable into position and cut to length required for installation.
3. Prepare cable using dimensions shown. **Be sure to allow for depth of terminal lug.** To prevent tape shield from unrolling, hold down edge with a single wrap of the supplied copper foil tape as shown. **Provide additional exposed conductor distance to account for growth during crimping of ALUMINUM lugs or connectors as follows:**

Aluminum Lug Growth Allowance	2/0-350	400-650	750-1000
	1/4" (6mm)	1/2" (13mm)	3/4" (19mm)

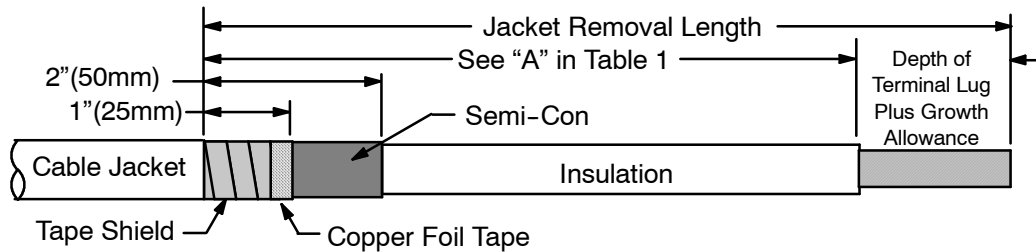

STEP 2 Install Ground Braid

1. Using 50% stretch, carefully wrap one (1) band of mastic around the cable jacket 1/4" (6mm) from jacket end as shown. **Position mastic carefully, it also serves as a marker for positioning the terminator. Cut mastic flush, do not overlap.**
2. Position preformed ground braid with short tail over tape shield and solder block centered over mastic strip. Secure ground braid to cable jacket using vinyl tape. Press solder block into mastic. See figure below.

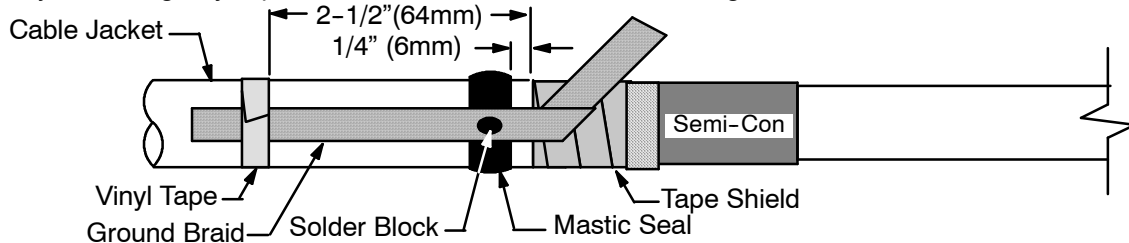

3. Using 50% stretch apply a second mastic band over the solder block and previously applied mastic maintaining the 1/4" (6mm) dimension. **Cut flush, do not overlap.**
4. Wrap two half-lapped layers of vinyl tape around mastic seal, carefully maintaining the 1/4" (6mm) dimension.
5. Wrap ground braid around cable tape shield one complete wrap, trim excess to prevent overlap and secure in place with constant force spring. Wrap spring in same direction as ground braid. **Cinch (tighten) the spring** after wrapping the final winding. Secure spring with two (2) wraps of vinyl tape.

SPECIAL NOTE FOR CLOTH OR PAPER SEMI-CON INSULATION SHIELD

In cable with cloth or paper semi-conductive shields it is recommended the shield be over wrapped with one half-lapped layer of highly stretched semi-conductive rubber tape such as Scotch™ No. 13.

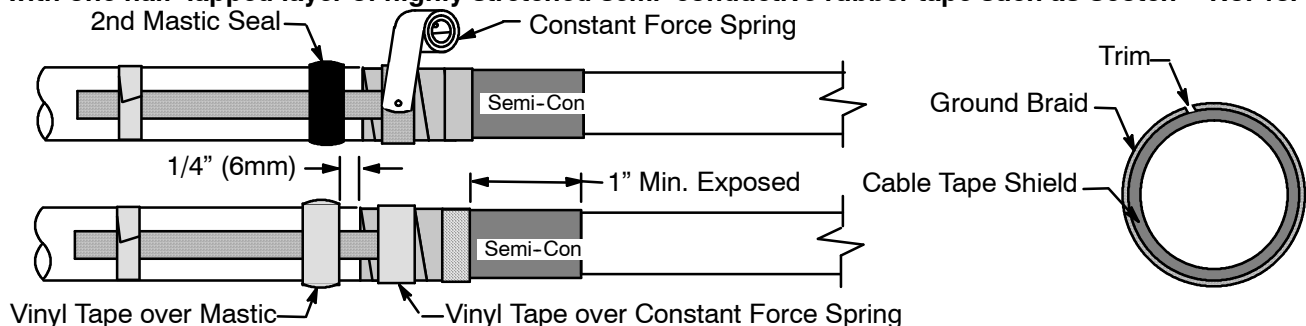

STEP 3 Install Lug or Connector

1. Check to insure termination assembly fits over the selected lug. If lug will not fit through the termination core, clean the insulation and slide termination on cable before installing lug. **Do not remove core at this time.**
2. Position connector/lug and crimp according to manufacturer's directions. Do not crimp the last 3/8" to 1/2" of the connector. Remove excess oxide inhibitor and sharp crimp flashings following crimping.

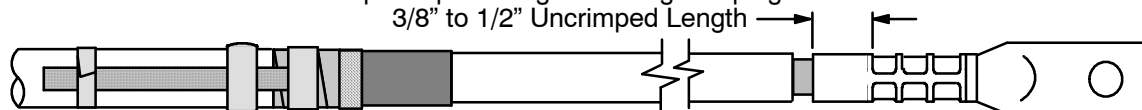

STEP 4 Clean Cable Insulation and Lug Barrel Using Standard Practice

1. Wipe the cable insulation with an approved solvent. **Do not allow solvent to touch semi-con insulation shield.**
2. If abrasive must be used:
 - a. Use on insulation only. **Do not use abrasive on semi-con insulation shield.**
 - b. Use only aluminum oxide abrasive; grit 120 or finer.
 - c. Be careful not to reduce the cable insulation diameter below that allowed by the kit.

STEP 5 Install Termination

1. **IMPORTANT:** A track resistant moisture seal must be made between termination insulator and lug/connector using gray silicone rubber electrical tape (contained in kit). Wrap a band of silicone tape around the base of the terminal lug.
 - a. If barrel diameter is equal to or greater than cable primary insulation, the tape band should not exceed 2 layers.
 - b. If barrel diameter is smaller than the cable primary insulation, use tape strip to form the tape band equal to insulation diameter, see below..
2. Cover the edge of the semi-con insulation shield with a liberal coating of silicone grease. **On this product the silicone grease does not serve as a lubricant. It must be used to fill the step at the semi-con cut off.**

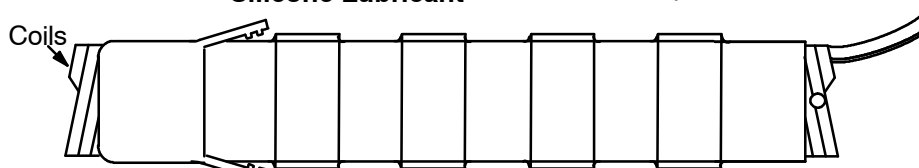
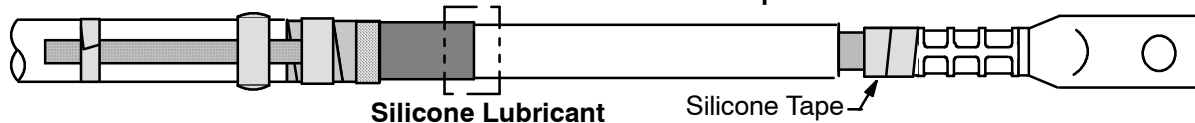

3. On lower termination with fold down skirt pull loose end of removable core through top of termination until the core is flush with bottom of the termination.

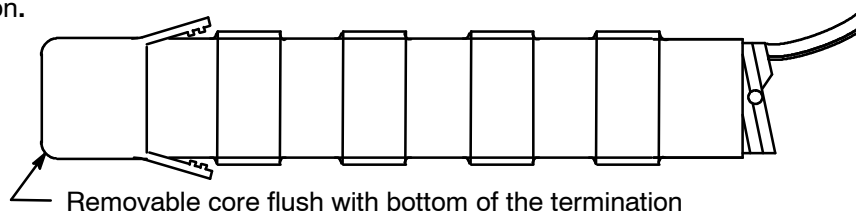

4. Slide the termination body onto the cable, **align terminator with forward edge of mastic seal** as shown below. Carefully begin to remove core while unwinding, counter-clockwise, starting with loose end. **Make sure the terminator body, not the core is butted up to the leading edge of the mastic seal, see below. Continue to remove core. Do not push or pull on the termination assembly while removing core.**

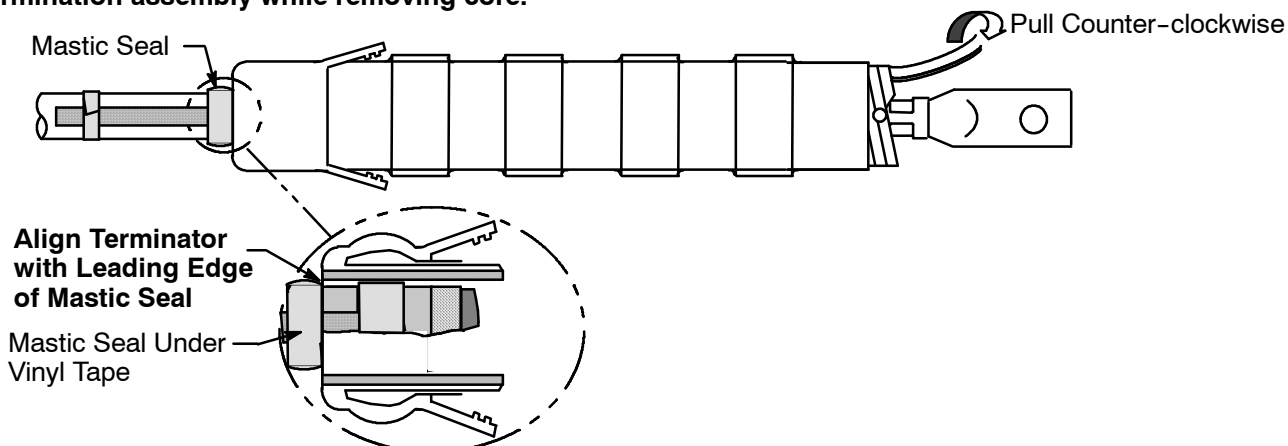

5. Apply a thin film of silicone lubricant to the skirt and mastic seal area. Do not lubricate the skirt tabs. Carefully fold down skirt over mastic seal.

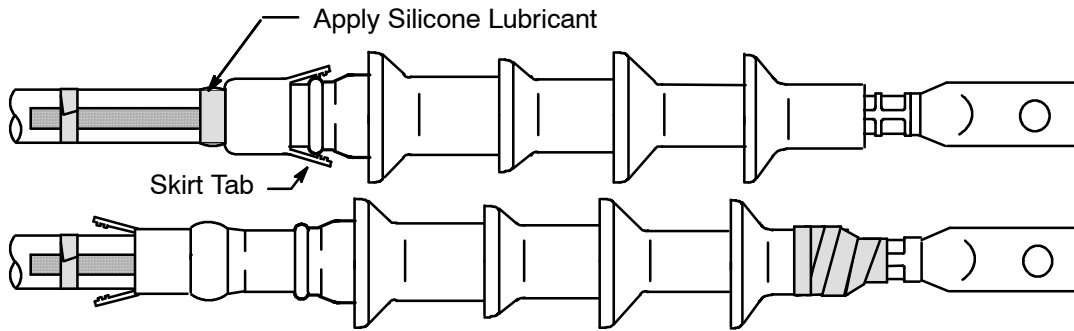

6. With termination installed, complete the lug area moisture seal using the remaining gray silicone rubber electrical tape. Overlap the termination insulator by approximately 1" and extend the tape wrapping over a non-crimped region of the lug/connector barrel with half lap configuration. See above.
7. Connect ground braid to system ground.

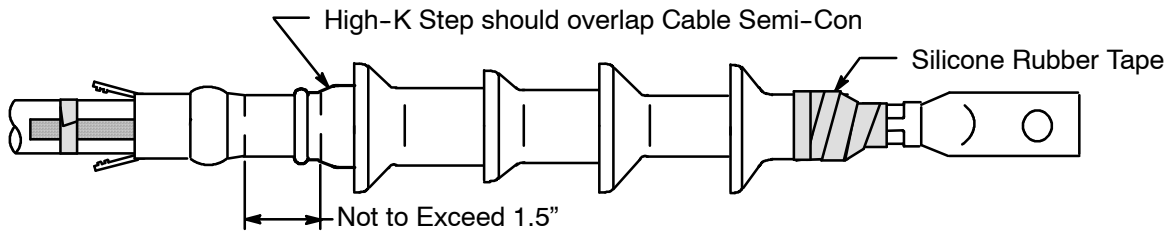

8. Confirm that High-K step does not exceed 1.5\".
-

Wire Shielded Cable

STEP 1 Prepare Cable

1. Check to be sure cable size fits within kit range as shown in the Termination Selection Chart, Page 1.
2. Train cable into position and cut to length required for installation.
3. Prepare cable using dimensions shown. **Be sure to allow for depth of terminal lug. Provide additional exposed conductor distance to account for growth during crimping of ALUMINUM lugs or connectors as follows:**

Aluminum Lug Growth Allowance	2-350	400-650	750-1000
	1/4"(6mm)	1/2"(13mm)	3/4"(19mm)

4. Bend leading 1-1/2" (38mm) of exposed shield wires back upon themselves to jacket edge.

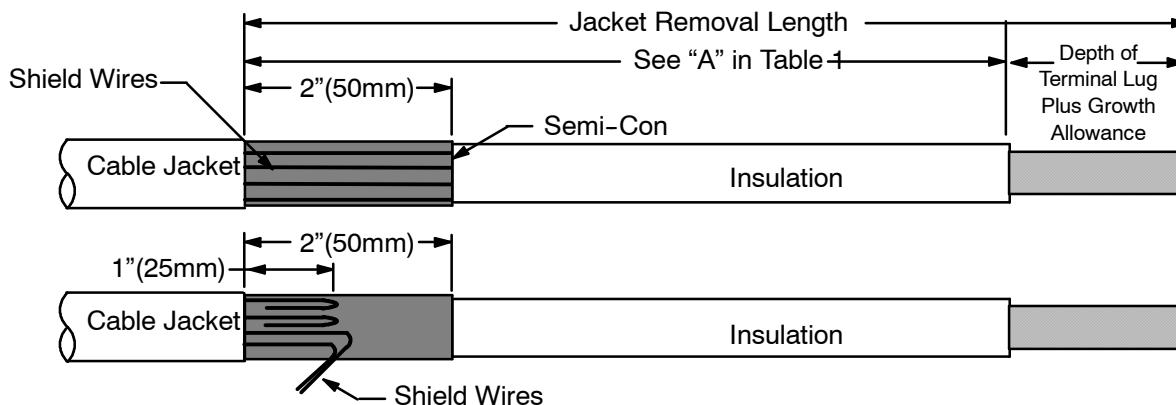

STEP 2 Install Ground Braid

1. Using 50% stretch, carefully wrap one (1) band of mastic around the cable jacket 1/4" (6mm) from jacket end as shown. **Position mastic carefully, it also serves as a marker for positioning the terminator. Cut mastic flush, do not overlap.**
2. Position preformed ground braid with short tail over tape shield and solder block centered over mastic strip. Secure ground braid to cable jacket using vinyl tape. Press solder block into mastic. See figure below.

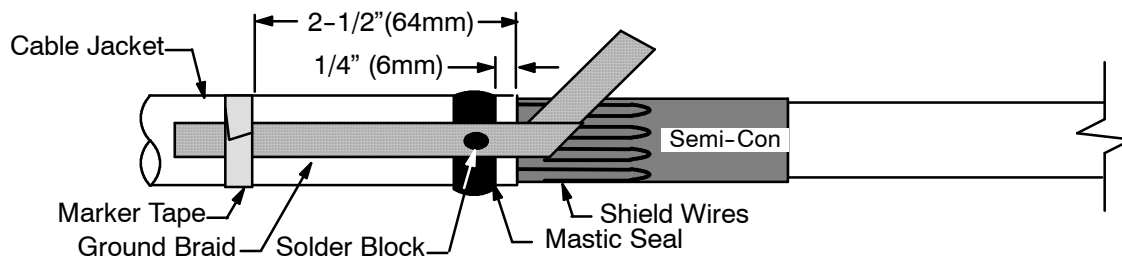

3. Using 50% stretch apply a second mastic band over the solder block and previously applied mastic maintaining the 1/4" (6mm) dimension. **Cut flush, do not overlap.**
4. Wrap two half-lapped layers of vinyl tape around mastic seal, carefully maintaining the 1/4" (6mm) dimension.
5. Wrap ground braid around cable tape shield one complete wrap, trim excess to prevent overlap and secure in place with constant force spring. Wrap spring in same direction as ground braid. **Cinch (tighten) the spring** after wrapping the final winding. Secure spring with two (2) wraps of vinyl tape.

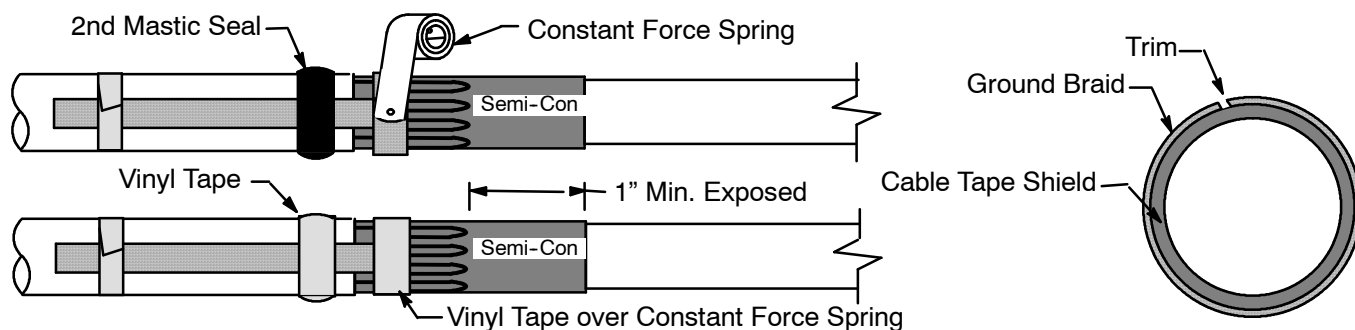

STEP 3 Install Lug or Connector

1. Check to insure termination assembly fits over the selected lug. If lug will not fit through the termination core, clean the insulation and slide termination on cable before installing lug. **Do not remove core at this time.**
2. Position connector/lug and crimp according to manufacturer's directions. Do not crimp the last 3/8" to 1/2" of the connector. Remove excess oxide inhibitor and sharp crimp flashings following crimping.

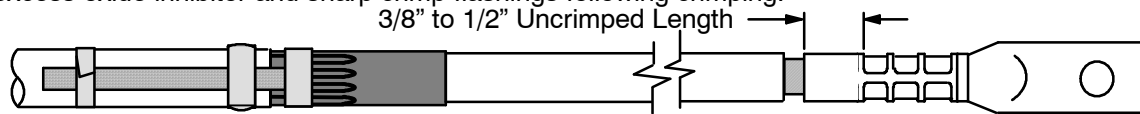

STEP 4 Clean Cable Insulation and Lug Barrel Using Standard Practice

1. Wipe the cable insulation with solvent saturated pads. **Do not allow solvent to touch semi-con insulation shield.**
2. If abrasive must be used:
 - a. Use on insulation only. **Do not use abrasive on semi-con insulation shield.**
 - b. Use only aluminum oxide abrasive; grit 120 or finer.
 - c. Be careful not to reduce the cable insulation diameter below that allowed by the kit.

STEP 5 Install Termination

1. **IMPORTANT:** A track resistant moisture seal must be made between termination insulator and lug/connector using gray silicone rubber electrical tape (contained in kit). Wrap a band of silicone tape around the base of the terminal lug.
 - a. **If barrel diameter is equal to or greater than cable primary insulation, the tape band should not exceed 2 layers.**
 - b. **If barrel diameter is smaller than the cable primary insulation, use tape strip to form the tape band equal to insulation diameter, see below..**
2. **Cover the edge of the semi-con insulation shield with a liberal coating of silicone grease. On this product the silicone grease does not serve as a lubricant. It must be used to fill the step at the semi-con cut off.**

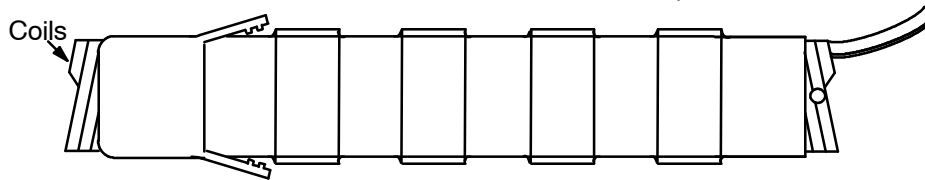
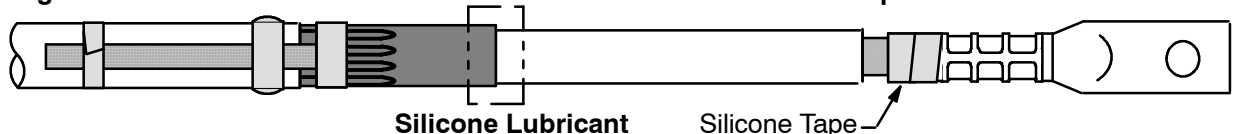

3. On lower termination with fold down skirt pull loose end of removable core through top of termination until the core is flush with bottom of the termination.

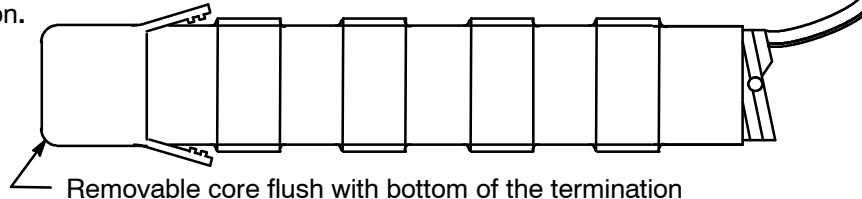

4. Slide the termination body onto the cable, align terminator with forward edge of mastic seal as shown below. Carefully begin to remove core while unwinding, counter-clockwise, starting with loose end. **Make sure the terminator body, not the core is butted up to the leading edge of the mastic seal, see below. Continue to remove core. Do not push or pull on the termination assembly while removing core.**

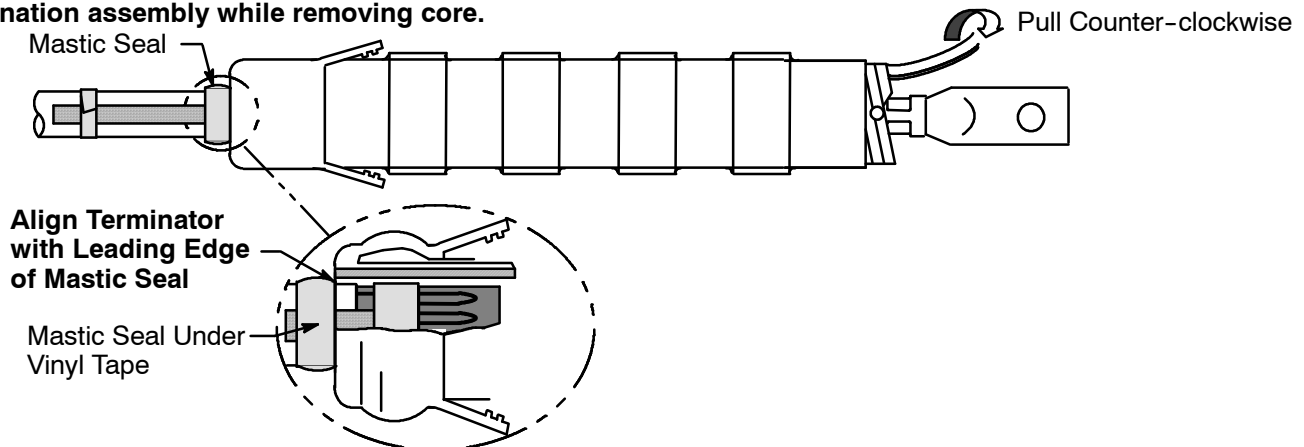

5. Apply a thin film of silicone lubricant to the skirt and mastic seal area. Do not lubricate the skirt tabs. Carefully fold down skirt over mastic seal.

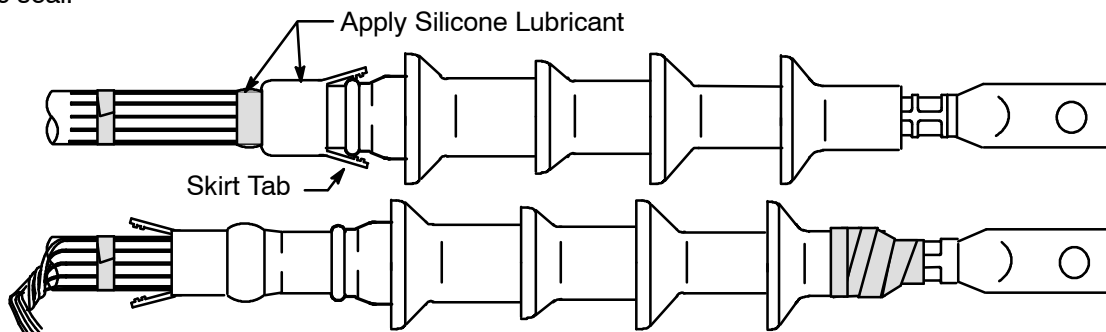

6. With termination installed, complete the lug area moisture seal using the remaining gray silicone rubber electrical tape. Overlap the termination insulator by approximately 1" and extend the tape wrapping over a non-crimped region of the lug/connector barrel with half lap configuration. See above.
7. Connect ground braid to system ground.

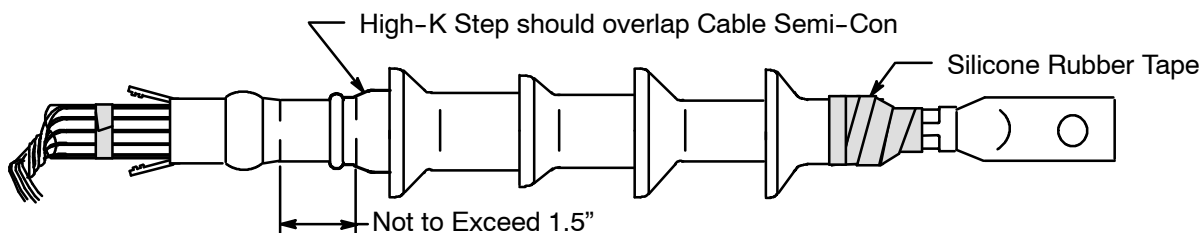

8. Confirm that High-K step does not exceed 1.5".
-

UniShield® Shield Cable

STEP 1 Prepare Cable

1. Check to be sure cable size fits within kit range as shown in the Termination Selection Chart, Page 1.
2. Train cable into position and cut to length required for installation.
3. Prepare cable using dimensions shown. **Be sure to allow for depth of terminal lug. Provide additional exposed conductor distance to account for growth during crimping of ALUMINUM lugs or connectors as follows:**

Aluminum Lug Growth Allowance	2-350	400-650	750-1000
	1/4"(6mm)	1/2"(13mm)	3/4"(19mm)

4. Install constant force spring and pull shield wires through semi-conductive jacket to leading edge of spring.
5. Remove constant force spring. Bend shield wires back upon cable jacket 1"(25mm). Cut excess shield wire and discard.

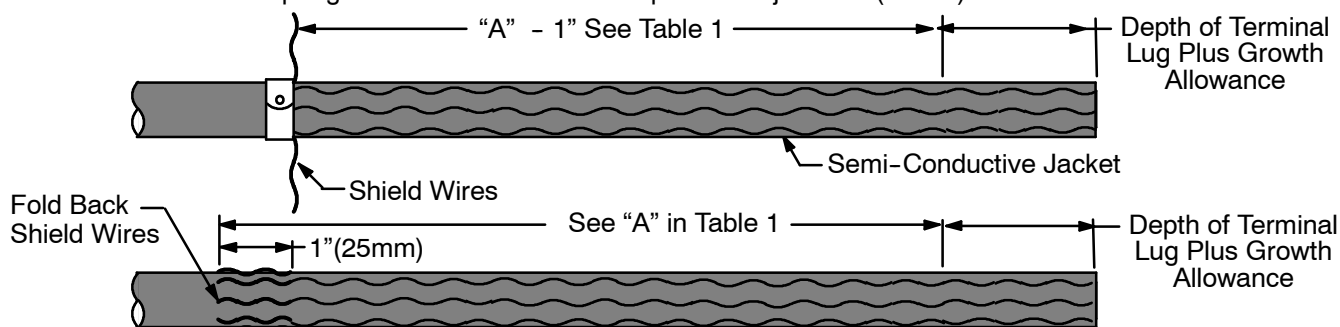

6. Remove semi-conductive jacket to dimension shown below.

To ease jacket removal, install constant force spring as shown and ring cut 80% through jacket. Remove jacket sections by pulling against constant force spring. DO NOT BELL SEMI-CON JACKET. Remove constant force spring. Some UniShield® cables feature dual-layer semi-conductive jackets. Both layers must be removed during cable preparation.

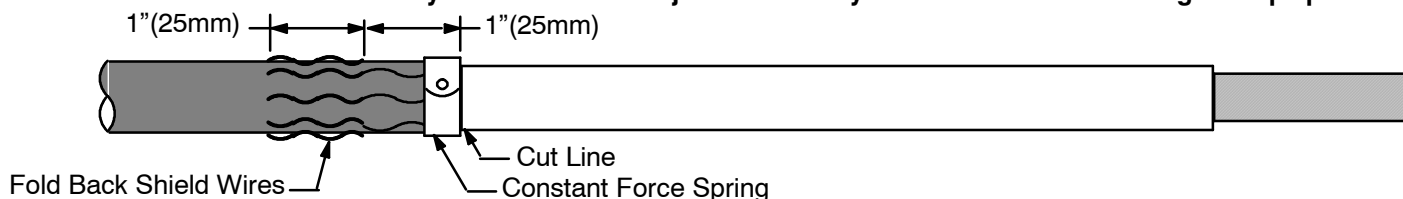

STEP 2 Install Ground Braid

1. Using 50% stretch, carefully wrap one (1) band of mastic around the cable jacket 1/4"(6mm) from shield wire end as shown. **Position mastic carefully, it also serves as a marker for positioning the terminator. Cut mastic flush, do not overlap.**
2. Position preformed ground braid with short tail over tape shield and solder block centered over mastic strip. Secure ground braid to cable jacket 4-1/2" (114mm) from cable semi-con edge using vinyl tape. Press solder block into mastic. See figure below.

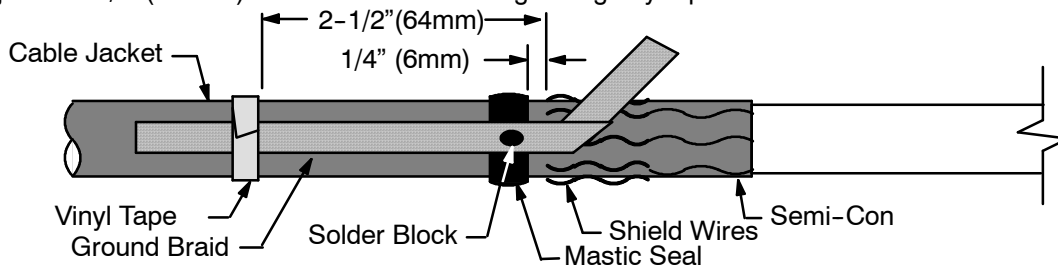

3. Using 50% stretch apply a second mastic band over the solder block and previously applied mastic. **Cut flush, do not overlap.**
4. Wrap two half-lapped layers of vinyl tape around mastic seal, carefully maintaining the 1/4" (6mm) dimension.
5. Wrap ground braid around cable shield wires one complete wrap, trim excess to prevent overlap and secure in place with constant force spring. Wrap spring in same direction as ground braid. **Cinch (tighten) the spring** after wrapping the final winding.

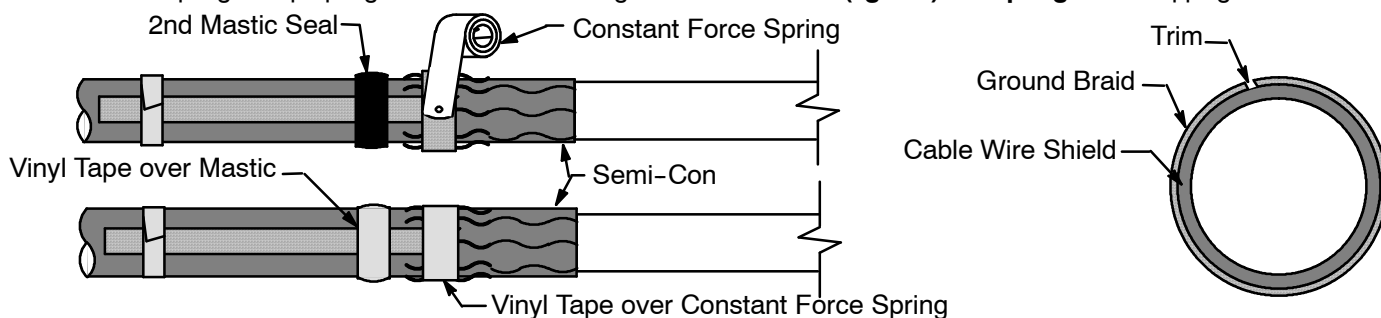

STEP 3 Install Lug or Connector

1. Check to insure termination assembly fits over the selected lug. If lug will not fit through the termination core, clean the insulation and slide termination on cable before installing lug. **Do not remove core at this time.**
2. Position connector/lug and crimp according to manufacturer's directions. Remove excess oxide inhibitor and sharp crimp flashings following crimping.

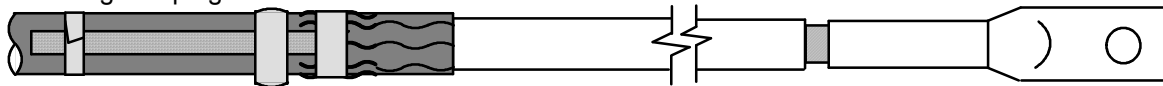

STEP 4 Clean Cable Insulation and Lug Barrel Using Standard Practice

1. Wipe the cable insulation with solvent saturated pads. **Do not allow solvent to touch semi-con insulation shield.**
2. If abrasive must be used:
 - a. Use on insulation only. **Do not use abrasive on semi-con insulation shield.**
 - b. Use only aluminum oxide abrasive; grit 120 or finer.
 - c. Be careful not to reduce the cable insulation diameter below that allowed by the kit.

STEP 5 Install Termination

1. **IMPORTANT:** A track resistant moisture seal must be made between termination insulator and lug/connector using gray silicone rubber electrical tape (contained in kit). Wrap a band of silicone tape around the base of the terminal lug.
 - a. **If barrel diameter is equal to or greater than cable primary insulation, the tape band should not exceed 2 layers.**
 - b. **If barrel diameter is smaller than the cable primary insulation, use tape strip to form the tape band equal to insulation diameter, see below.**
2. Cover the edge of the semi-con insulation shield with a liberal coating of silicone grease. On this product the silicone grease does not serve as a lubricant. It must be used to fill the step at the semi-con cut off.

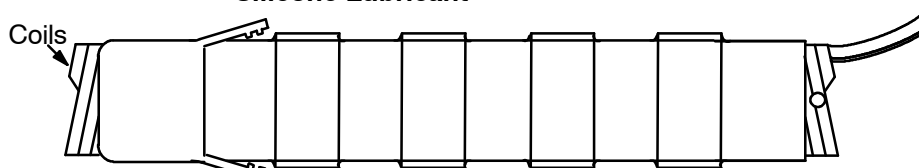
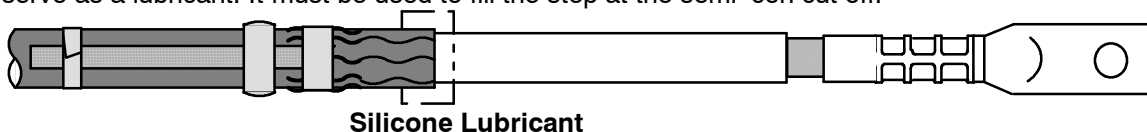

3. On lower termination with fold down skirt pull loose end of removable core through top of termination until the core is flush with bottom of the termination.

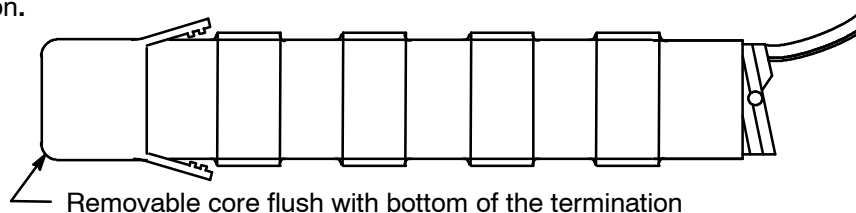

4. Slide the termination body onto the cable, **align terminator with forward edge of mastic seal** as shown below. Carefully begin to remove core while unwinding, counter-clockwise, starting with loose end. **Make sure the terminator body, not the core is butted up to the leading edge of the mastic seal, see below. Continue to remove core. Do not push or pull on the termination assembly while removing core.**

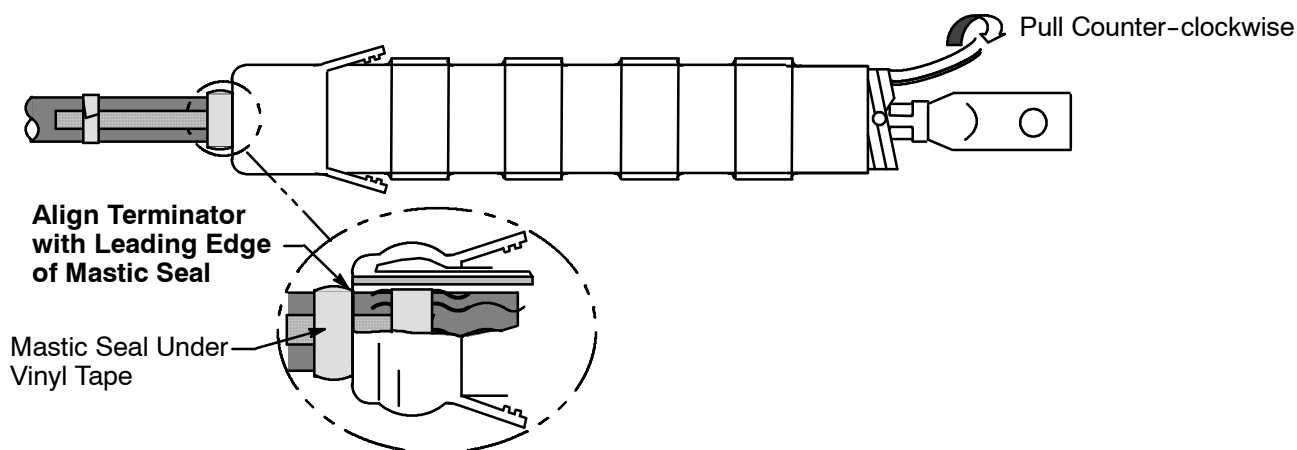

5. Apply a thin film of silicone lubricant to the skirt and mastic seal area. Do not lubricate the skirt tabs. Carefully fold down skirt over mastic seal.

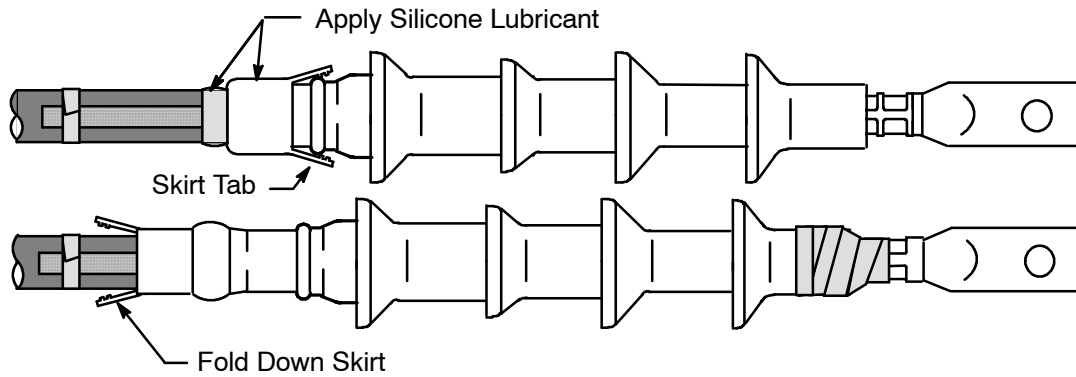

6. With termination installed, complete the lug area moisture seal using the remaining gray silicone rubber electrical tape. Overlap the termination insulator by approximately 1" and extend the tape wrapping over a non-crimped region of the lug/connector barrel with a half lap configuration, see above.
7. Connect ground braid to system ground.

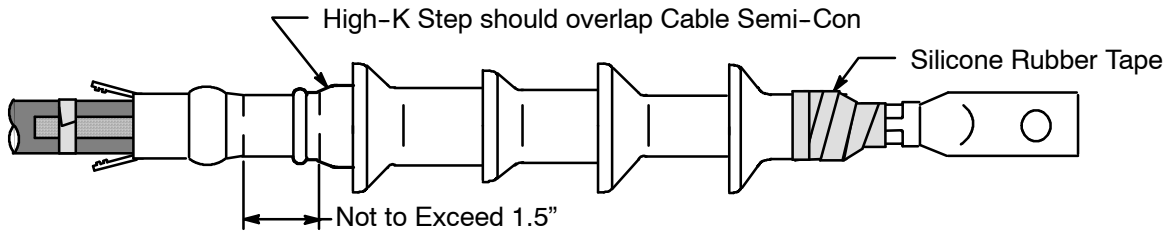

8. Confirm that High-K step does not exceed 1.5".