

Carlton® Rectangular Floor Box, Activation Kit and Covers Installation Instructions

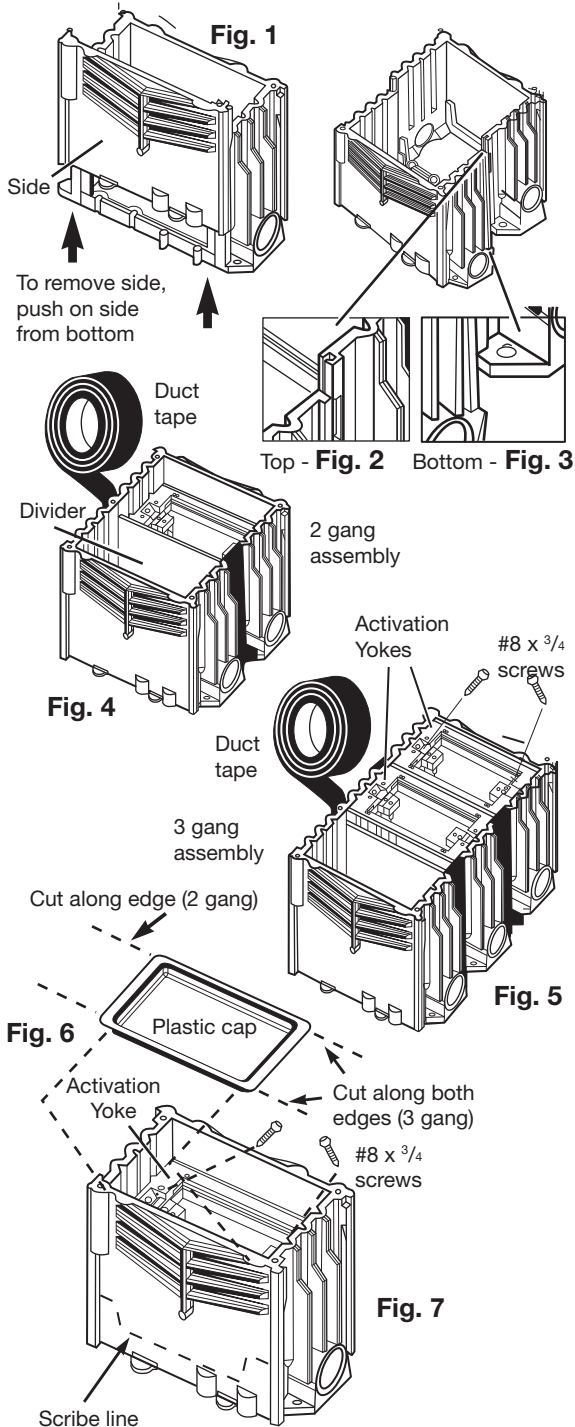

Carlton® Rectangular Floor Box E976RFB

PREPARATION

Single Gang Application

1. Single gang box comes assembled.

Two Gang Application

1. Two single gang boxes are required (2 pieces of E976RFB).
2. Remove the appropriate side of each box to gang them properly. **(Fig. 1)** Slide boxes together by aligning the top interlocking tabs on the side of the base and the bottom tabs and slots. **(Fig. 2 and Fig. 3)** THESE BOXES DO NOT SNAP TOGETHER; THEY SLIDE TOGETHER!

Three Gang Application

1. Three single gang boxes are required (3 pieces of E976RFB).
2. Repeat step 2 under Two Gang Application instructions.

NOTE: When ganging 2 or 3 boxes, you must apply a piece of duct tape along each side and bottom seam.

(Fig. 4 and Fig. 5)

Before Concrete Pour

1. Set box on level surface with minimum concrete pour of 3¹/₂".
NOTE: With 3¹/₂" concrete pour, space for cord plug between electrical device and closed cover is 7/8".
2. Set the box so there is a minimum 1/2" exposure after concrete pour.
IMPORTANT! For above grade installation, provide adequate concrete thickness under the floor to preserve the fire rating of the floor in accordance with the building codes.
3. Secure plastic cap to floor box before pour by cross taping the cap. **(Fig.6)**
 - a. For two gang applications, cut the edge of one cap, then overlap the second. Duct tape the underside seam.
 - b. For three gang applications, cut both edges of center cap. Overlap both outer caps onto center cap and duct tape both underside seams.

Conduit Connections

1. Use Carlton PVC cement to adhere Carlton Plus 40 or Carlton Plus 80 nonmetallic conduit or Flex Plus Blue ENT (electrical nonmetallic tubing) to utilized ports.
2. To feed parallel runs of 3/4" conduit use Carlton "Y" adapter E972Y.
3. Use Carlton PVC cement to adhere reducer-plugs (provided with Floor Box) to seal off unused conduit openings.
4. Floor box sides may be drilled for conduit feeds; to access, stay above noticeable "scribe lines" on side. **(Fig.7)**

IMPORTANT! Follow solvent cement manufacturers' instruction and safety precautions.

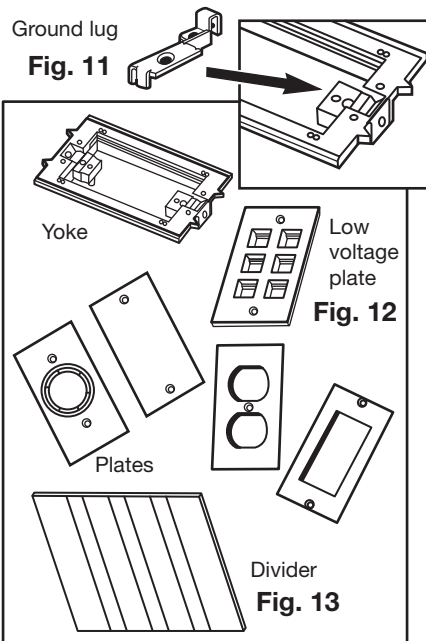
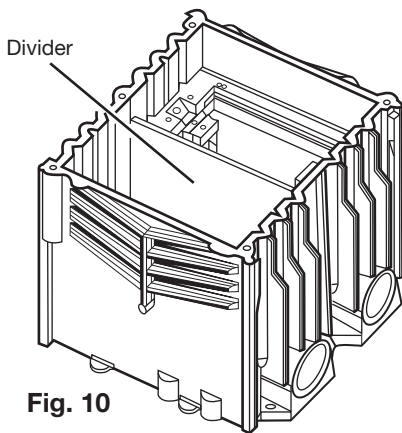
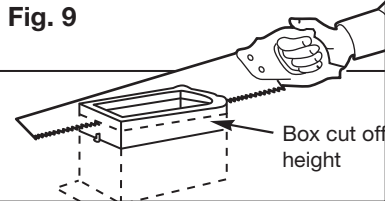
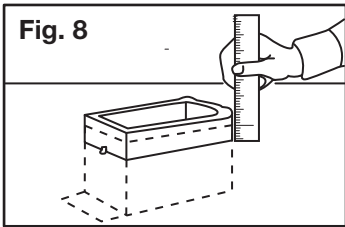

Activation Kit:

- Yoke/Activation ring
- Divider
- Insert plates
- Screws

Trim Out After Concrete Pour

1. Remove plastic cap.
2. Determine floor box height and mark cut off line. **(Fig. 8)**
 - a. For Carlon® Nonmetallic Cover Installation go to page 3., steps 1, 2 and 3.
 - b. For Carlon® Brass Cover Installation go to page 4, steps 1, 2 and 3.
3. Using handsaw, cut off box at marked height. **(Fig. 9)**

Carlon® Activation Kit E976AK2 Installation

NOTE: Carlon® Device Mounting Yoke may be either recessed down in the floor box, or installed directly to bottom of the Carlon® Covers.

Single Gang Yoke Installation

Yoke Recessed in Floor Box

1. Align Yoke in Floor Box slots **(Fig. 7)** and move yoke to desired level.
2. Insert #8 x 3/4" pan head screws provided in Activation Kit into angled holes at the ends of Yoke and tighten into Floor Box ends.

Yoke Mounted directly to Carlon® Nonmetallic Covers

1. Position Yoke on underside of Cover.
2. Fasten Yoke to Cover using four #6 x 1/2" flat head screws provided in Activation Kit.

Yoke Mounted directly to Carlon® Brass Covers

1. Position Yoke on underside of Cover and retain in place using two #8 x 1 1/8" pan head screws provided with Cover.
2. Insert #8 x 1 1/8" pan head screws into angled holes at the ends of cover and tighten into Floor Box ends.

Two and Three Gang Divider and Yoke Installation

IMPORTANT! It is necessary in accordance with NEC regulations to keep low voltage (voice, data or video) separate from power requirements. To comply, Divider provided in Activation Kit must be used.

Divider

1. If using two or three gang box for either all power or all communication, Divider **(Fig.13)** is not required. Go to Step 5 per your application.
2. Break off the edge of the Yoke (score line) on the side that the Divider is to be located. **(Fig.10)**
3. Cut Divider to length.
 - a. For Carlon® Nonmetallic Cover, cut Divider 3/4" below carpet flange underside at installed position.
 - b. For Carlon® Brass Cover, cut Divider 1/4" below carpet flange underside at installed position.
4. Slide divider down into slots created when 2 or 3 Carlon® E976RFB Floor Boxes are ganged together. **(Fig. 10)**

Yoke Recessed in Floor Box

5. Align Yoke in Floor Box slots **(Fig. 5)** and move yoke to desired level.
6. Insert #8 x 3/4" pan head screws provided in Activation Kit into angled holes at the ends of Yoke and tighten into Floor Box ends.

Yoke Mounted to Carlon® Nonmetallic Covers

5. Position Yoke on underside of Cover.
6. Fasten Yoke to Cover using four #6 x 1/2" flat head screw provided in Activation Kit.

Yoke Mounted to Carlon® Brass Covers

5. Position Yoke on underside of Cover and retain in place using two #8x1-1/8" pan head screws provided with Cover.
6. Insert #8 x 1 1/8" pan head screws into angled holes at the ends of cover and tighten into Floor Box ends.

Plate Installation Power Applications

1. Attach conductors to a standard electrical device (Duplex, GFCI or Single Round receptacle). Canadian Applications: Per Canadian electric code, a separate bonding connection is required in nonmetallic electrical boxes. Utilize Grounding Lug (**Fig. 11**) and green Ground Screw provided with Yoke.
2. Install electrical device in Yoke with device furnished 6-32 screws.
3. Attach the appropriate device plate using #6-32 x 5/8" oval head screw(s) provided in Activation Kit.

Plate Installation low Voltage (Voice, Data & Video) Applications

1. A 6 port Low Voltage Plate (**Fig. 12**) is included in Activation Kit E976AK2. The Low Voltage Plate will accept the following Manufacturer's "Keystone" style jacks:
 - Allen Tel* - Amp* - Dynacom* - Homaco* - Hubbell* - Krone* - Leviton* - 3M* - Ortronics* - Wiremold* - Hellermann* Tyton*
2. Following Manufacturer's instructions connect wire or cable to the jack(s). Snap wired jack(s) into Low Voltage Plate with jack(s) aligned in the "UP" position. Snap blank modules into unused ports.
3. Attach the Low Voltage Plate to the yoke using #6-32 x 3/4" oval head screws provided with Low Voltage Plate.

Carlon® Nonmetallic Covers Installation E9761_*, E9762_* & E9763_*

* **B=Brown; C=Caramel; S=Slate**

NOTE: Carlon® Activation Kit E976AK2 is required for installation.

Nonmetallic carpet flanges will conceal opening sizes as follows: Single Gang 7³/₈" x 5¹/₈", Two Gang 7³/₈" x 8¹/₂" and Three Gang 7³/₈" x 11³/₄".

1. Determine type and thickness of floor covering to be used. Covers may be installed in carpet, tile or other floor covering.

NOTE: Remember to check height of finished floor covering.

2. Mark a line 1/8" below desired final installed height of nonmetallic Cover's top surface. Using a saw, cut off box at marked height. (Refer to page 2, Trim Out After Concrete Pour)

3. Methods of Installation

- a. **Tile or Carpet:** The cover may either be installed as is with carpet flange or,
- b. **Tile:** Carpet flange may be removed using a sawsall, jig saw or saber saw to cut along the score lines. Avoid using pliers or similar tools to break away the flange. (**Fig. 14**) If option of removing carpet flange is selected, set Cover so top surface of flange is at finished tile height. Work tile to Cover flange.
- c. **Carpet:** Install carpet up to Floor Box outside edge.
- d. **Tile or Carpet:** Cover may be inverted and a section of carpet or tile installed in the Cover to make the Cover less noticeable. Use template on page 4, Fig. 17, to size section of floor covering to be installed in inverted cover. If inverted cover option is chosen, small Cord Door must be removed and re-installed on the opposite side of the cover. (**Fig. 14**)

4. Yoke provided in Activation Kit may be either mounted directly to bottom of the Nonmetallic Cover or recessed down in the box. See Activation Kit Installation page 2.

5. To attach Cover to Floor Box, insert #8 x 1 1/8" pan head screws (provided with Cover) into angled holes at the ends of Cover and tighten into Floor Box ends. (**Fig. 15**)

GASKET CONDITIONING: During initial installation, remove Cover and while in the installed position, apply a light surface coat of petroleum jelly to the top surface of this gasket, to keep it supple and prevent water entry!

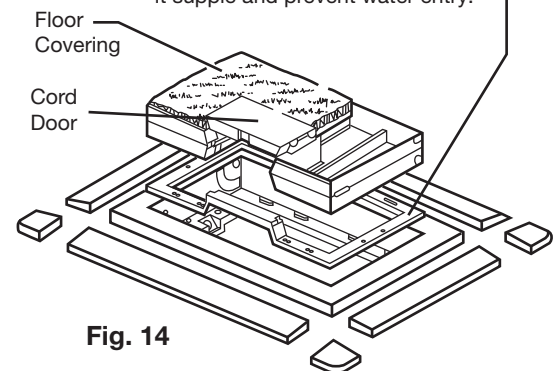

Fig. 14

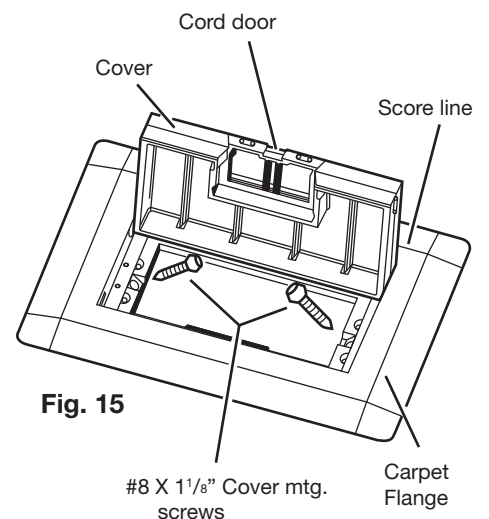

Fig. 15

Carlon® Brass Covers E9761BR, E9762BR & E9763BR

NOTE: Carlon® Activation Kit E976AK2 is required for installation.
 Brass flanges will conceal opening sizes as follows: Single Gang
 $6\frac{3}{4}" \times 4\frac{1}{2}"$, Two Gang $6\frac{3}{4}" \times 7\frac{3}{4}"$ and Three Gang $6\frac{3}{4}" \times 11"$.

1. Determine type and thickness of floor covering to be used. Covers may be installed in carpet, tile or other floor covering.
2. Mark a line $\frac{3}{16}"$ below desired final installed height of Brass Cover's top surface. Using a saw, cut off box at marked height. (Refer to page 2, Trim Out After Concrete Pour)

Caution: If $1\frac{1}{2}"$ or more is removed from top of box, larger section of support ribs on the ends of the box may be above concrete. **If needed, remove top of end support ribs to allow finished floor covering to be installed within $\frac{5}{8}"$ of box inside.**

3. Methods of Installation
 - a. **Tile:** Set Cover so top surface of flange is at finished tile height. Work tile to Cover flange.
 - b. **Carpet:** Install carpet up to Floor Box outside edge.
4. Yoke provided in Activation Kit may be either mounted directly to bottom of the brass cover or recessed down in the box. See Activation Kit Installation page 2.
5. To attach Cover to Floor Box: Insert #8 x $\frac{11}{8}"$ pan head screws (provided with Cover) into angled holes at the ends of Cover and tighten into Floor Box ends. **(Fig. 16)**

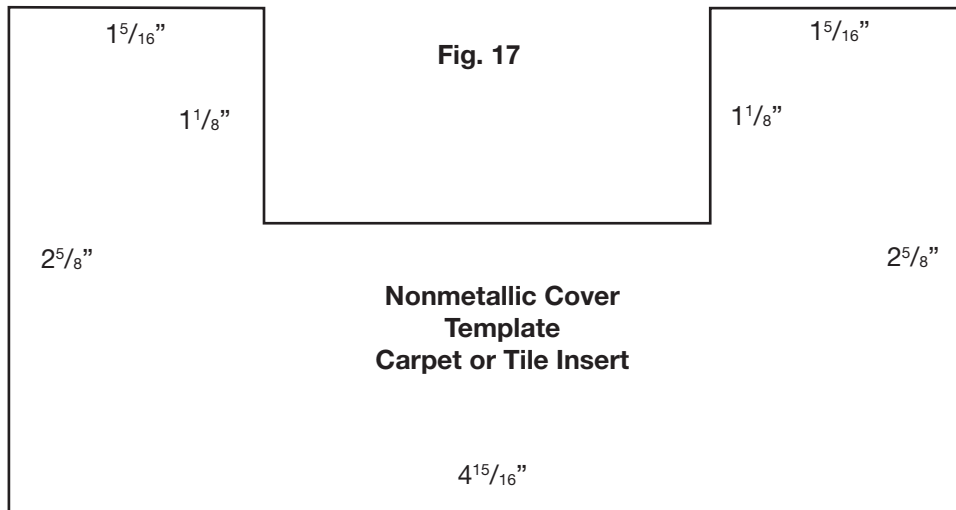
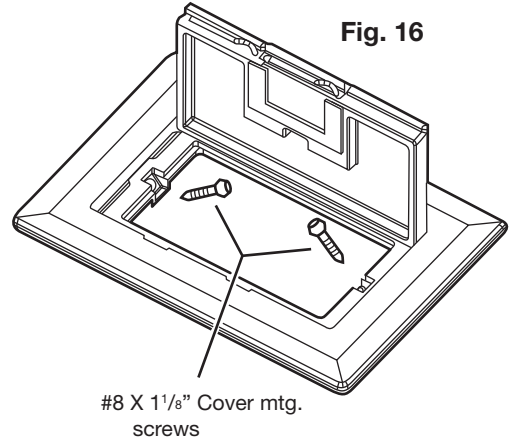

WARRANTY: Thomas & Betts sells this product with the understanding that the user will perform all necessary tests to determine the suitability of this product for the user's intended application. Thomas & Betts warrants that this product will be free from defects in materials and workmanship for a period of two (2) years following the date of purchase. Upon prompt notification of any warranted defect, Thomas & Betts will, at its option, repair or replace the defective product or refund the purchase price. Proof of purchase is required. Misuse or unauthorized modification of the product voids all warranties.

Limitations and Exclusions: THE ABOVE WARRANTY IS THE SOLE WARRANTY CONCERNING THIS PRODUCT, AND IS IN LIEU OF ALL OTHER WARRANTIES EXPRESS OR IMPLIED, INCLUDING BUT NOT LIMITED TO ANY IMPLIED WARRANTY OF MERCHANTABILITY OR FITNESS FOR A PARTICULAR PURPOSE, WHICH ARE SPECIFICALLY DISCLAIMED. LIABILITY FOR BREACH OF THE ABOVE WARRANTY IS LIMITED TO COST OF REPAIR OR REPLACEMENT OF THE PRODUCT, AND UNDER NO CIRCUMSTANCES WILL THOMAS & BETTS BE LIABLE FOR ANY INDIRECT, SPECIAL, INCIDENTAL OR CONSEQUENTIAL DAMAGES.

Thomas & Betts Corporation
 Memphis, Tennessee
 www.tnb.com