

**19-IN. RACK-MOUNT/DESKTOP CASE, TYPE 1**

**INDUSTRY STANDARDS**

NEMA Type 1  
IEC 60529, IP20  
**Exterior Dimensions**  
EIA 310-D / IEC 297-1  
DIN 41494 Part 1

**APPLICATION**

Desktop cases house circuit boards and other electronic equipment in a rigid framework with easy front and rear access. Rack cases are 19-in. rack mountable with integral mounting provided in the front bezel.

**FEATURES**

- Removable top and bottom covers attach directly to case framework for maintenance convenience
- Bottom cover has multiple rows of holes for ventilation
- Front bezel includes mounting provisions for 19-in. rack mounting as well as mounting for front panel options for application flexibility
- Top and bottom of framework have mounting provisions for optional support rails for application flexibility. Mounting holes are spaced on 10-mm centers front to back.
- Case framework is assembled for quick installation. Top cover, bottom cover, anti-skid feet and mounting hardware are included.
- Mounting hardware for optional front and rear panels are included with case for installation convenience

**SPECIFICATIONS**

- One-piece aluminum die cast front bezel and rear bezel are connected front-to-back with aluminum extrusions to form a rigid structural framework
- Sides on 3U- and 4U-tall cases are the aluminum front-to-back extrusions. The 6U-tall case has two aluminum extrusions with a steel middle panel on each side.
- Covers are 1-mm steel and have grounding provisions

**FINISH**

Framework has an RAL 7030 stone-gray textured finish. Top and bottom covers have an RAL 7035 light-gray textured finish on the outside and a plated finish on the inside.

**BULLETIN: DEC1**
**Standard Product**

Catalog Number	AxBxC mm/in.	E mm/in.	F mm/in.	G mm/in.	H mm/in.	Rack Units
ERC3U4837	133 x 483 x 375 5.20 x 19.00 x 14.80	131 5.14	103 4.04	57 2.25	110 4.33	3
ERC4U4843	177 x 483 x 435 7.00 x 19.00 x 17.10	175 6.89	147 5.77	102 4.00	155 6.08	4
ERC6U4843	266 x 483 x 435 10.50 x 19.00 x 17.10	264 10.39	235 9.27	190 7.50	243 9.58	6

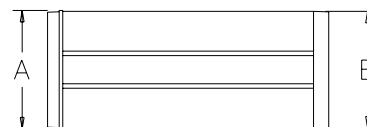
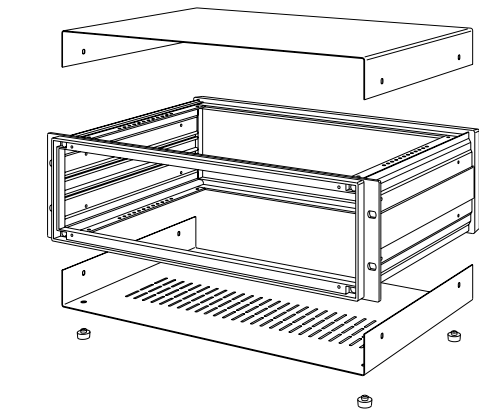
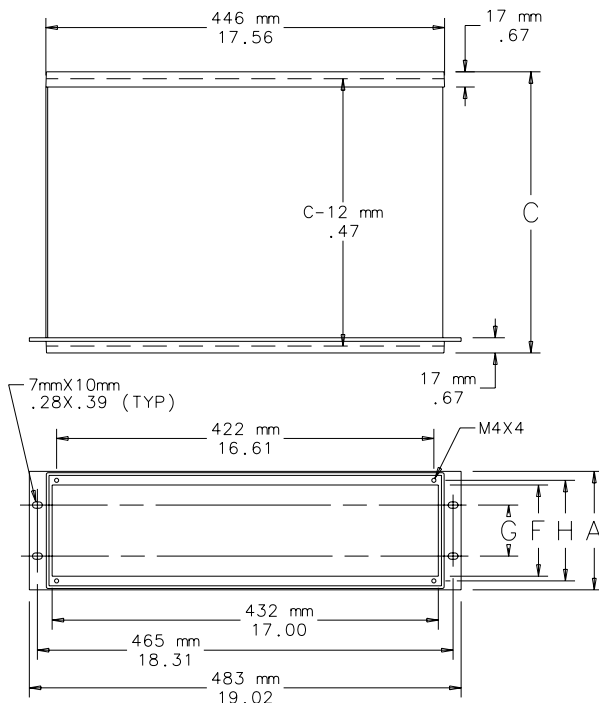

C2779-C

### FRONT PANELS

Blank front panel provides a means to close front or rear of a desktop case. The smooth anodized surface is ideal for mounting controls or meters, etc. The front panel is 2.5-mm thick and fits into the 6-mm (0.24-in.) recess on front (or rear) of the case. Hardware to mount front panel is furnished with case.

**BULLETIN: DEC1**

Catalog Number	D (mm)	D (in.)	H (mm)	H (in.)
ERCFP3U48	120.5	4.74	110.0	4.33
ERCFP4U48	165.0	6.50	154.5	6.08
ERCFP6U48	253.8	9.99	243.4	9.58

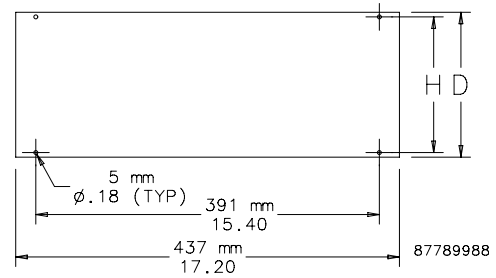

### REAR PANELS

Rear panels are 2.5-mm thick anodized aluminum. They include a row of ventilation slots (vertical) along the upper edge of panel. 6U covers have two rows of slots. Hardware to mount rear panel is furnished with case.

**BULLETIN: DEC1**

Catalog Number	D mm/in.	H mm/in.	J mm/in.
ERCRP3U48	121 4.74	110 4.33	25 .98
ERCRP4U48	165 6.50	155 6.08	25 .98
ERCRP6U48	254 9.99	243 9.58	25 .98

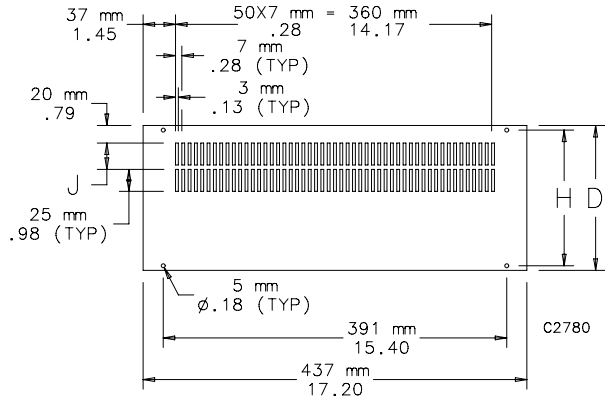

### FRONT HANDLES

Handles facilitate movement of the desktop case and installation of the case in a 19-in. rack. They are mounted to the rack-mounting flanges on the 19-in. front bezel. Front bezels have holes partially drilled and countersunk for location and must be drilled through before handle installation. Handles are die-cast aluminum and finished in light-gray (RAL 7030). Package includes two handles with necessary mounting hardware.

**BULLETIN: DEC1**

Catalog Number	A (mm)	A (in.)
ERCFH3U	133	5.20
ERCFH4U	177	7.00
ERCFH6U	266	10.50

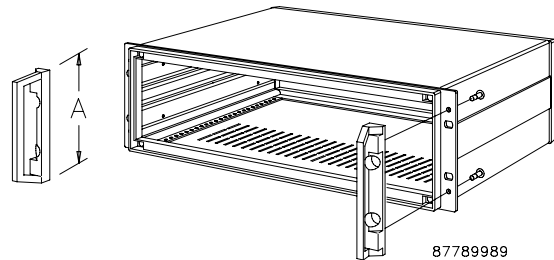

### SUPPORT RAIL KIT

Support rails are recommended for mounting and supporting the weight of bulky components inside a desktop case. Support rails have mounting holes and rectangular slots for mounting components. Rails are 1.5-mm steel with a plated finish. M4 nuts are welded to the rail ends for easy attachment to the case. Mounting holes in the desktop case are spaced on 10-mm centers from front to back, allowing a variety of positions for support rails. Support rail kit includes front rail, rear rail and mounting hardware.

BULLETIN: DEC1

Catalog Number	Kit Includes
ERCRF48	1 front rail, 1 rear rail and mounting hardware

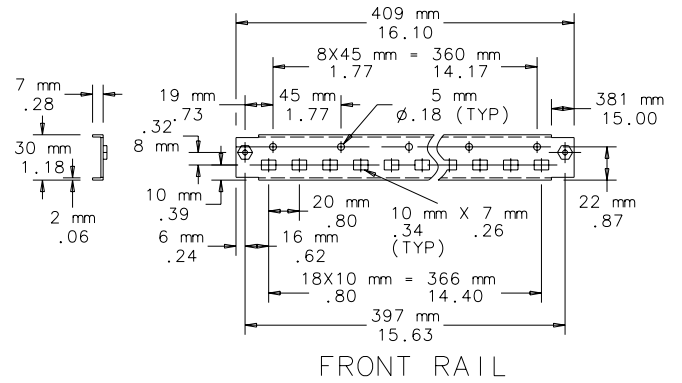

FRONT RAIL

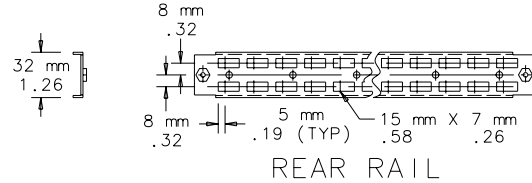

REAR RAIL

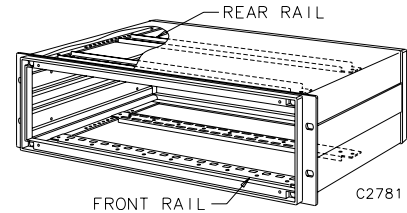

**Notes**