

M-12569

2

LIST OF PARTS

DESCRIPTION	MATERIAL	FINISH
GANGABLE SPACER	STEEL	GALVANIZED
END CAPS	STEEL	GALVANIZED
MOUNTING BRACKET	STEEL	GALVANIZED
SUPPORT BRACKET	STEEL	GALVANIZED
FASTENERS	STEEL	ZINC

DIMENSION SHEET FOR CAT. NO. HBL986

REPAIRABLE NON-REPAIRABLE

B

M-12569

2

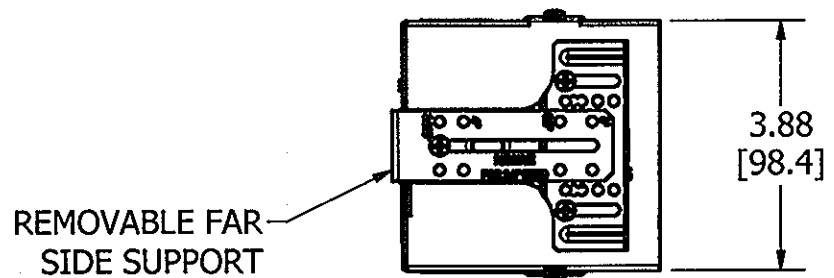
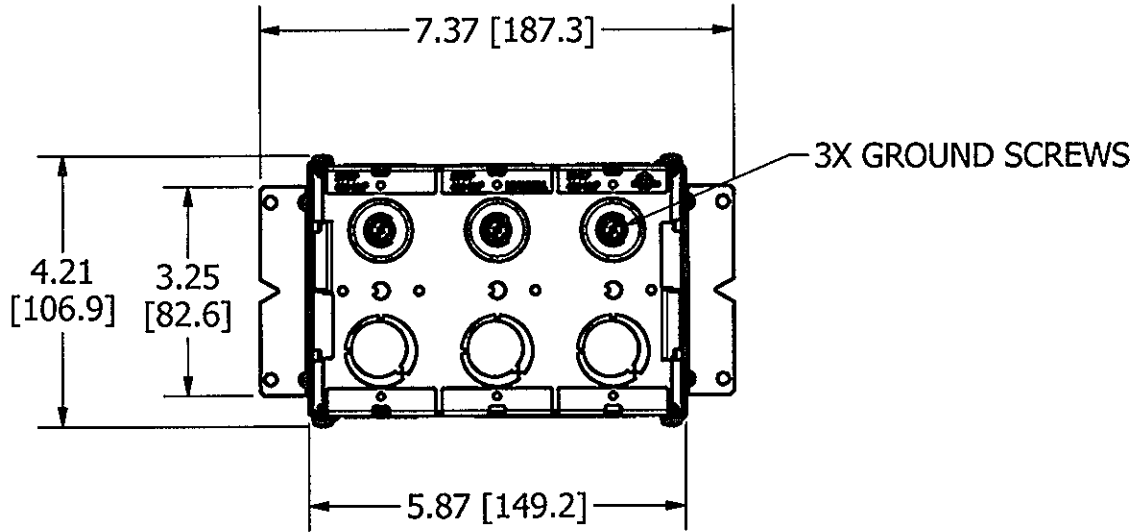
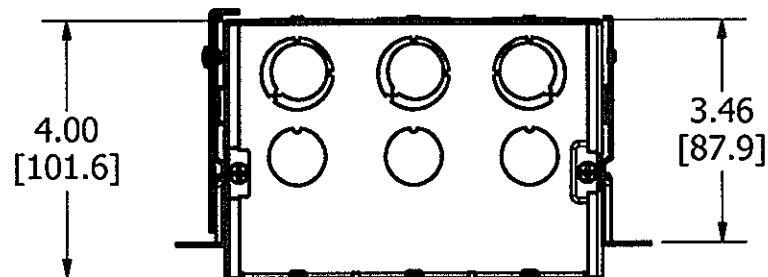
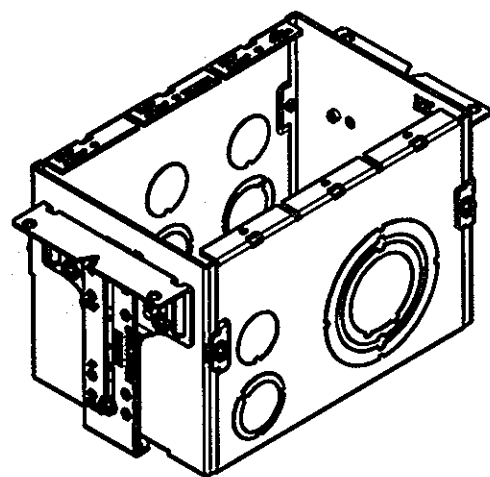

ADJUSTABLE 1/2 [12.7], 5/8 [15.9], 3/4 [19.1], 1 [25.4], 1-1/4 [31.8]

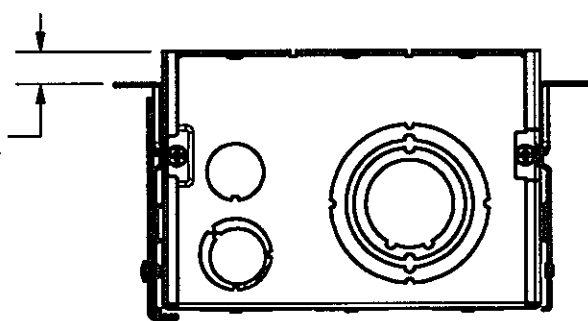

2	REVISED PER DCN 20729	SBW	9/8/2014
1	INITIAL RELEASE DCN 20490	SBW	5/8/2014
SYM	DESCRIPTION	APP	DATE

THE DESIGN AND DIMENSIONS OF THE PRODUCT SHOWN ON THIS DRAWING ARE SUBJECT TO CHANGE WITHOUT NOTICE

TITLE
3 GANG DEEP WALLBOX, GANGABLE

- NOTES:
1. ALL DIMENSIONS ARE IN INCHES AND [MILLIMETERS].
 2. MOUNTING BRACKETS AJUSTABLE FOR 1/2 [12.7] TO 1-1/4 [31.8] WALL THICKNESS.
 3. FAR WALL SUPPORT INCLUDED. ADJUSTABLE RANGE: 3.63 [92.1] TO 6.00 [152.4]
 4. ACCEPTS HBL989 VOLTAGE PARTITION, SOLD SEPARATELY.
 5. BOX VOLUME: 79 IN³ [1293 CM³].
 6. cULus LISTED.

KNOCKOUTS	
TRADE SIZE	LOCATIONS
1/2"	3 - TOP, 1 - BOTTOM
1/2", 3/4" ECCENTRIC	3 - TOP, 1 - BOTTOM, 3 - BACK
1", 1 1/4, 1 1/2", 2" CONCENTRIC	1 - BOTTOM

TOLERANCES UNLESS OTHERWISE SPECIFIED .XX = ± .01 .XXX = ± .005 ANGLES = ± 2°	WIRING DEVICE-KELLEMS HUBBELL INCORPORATED SHELTON, CT.	
	DR. BY SBW	APP. BY
	TR. BY	SCALE 1/3
	CHK'D BY	DATE 4/28/2014